



US00D435442S

# United States Patent [19] Candelin

[11] Patent Number: Des. 435,442

[45] Date of Patent: \*\* Dec. 26, 2000

## [54] PACKAGING

[75] Inventor: Peter M. Candelin, Pasadena, Calif.

[73] Assignee: Ultravit Enterprises, Inc., Pasadena, Calif.

[\*\*] Term: 14 Years

[21] Appl. No.: 29/097,756

[22] Filed: Dec. 14, 1998

[51] LOC (7) Cl. .... 09-03

[52] U.S. Cl. .... D9/341; D9/517; D9/415

[58] Field of Search ..... D9/517, 503, 341,  
D9/418, 432, 433, 415, 337; 206/775, 779,  
780

## [56] References Cited

### U.S. PATENT DOCUMENTS

D. 87,489	8/1932	Rynveld .	
D. 278,125	3/1985	Benham .....	D9/418
D. 278,126	3/1985	Benham .....	D9/418
D. 283,310	4/1986	Sussman .....	D9/420
D. 291,065	7/1987	Pugh .....	D9/418
D. 305,985	2/1990	Miller .....	D9/418
D. 306,829	3/1990	Golkar .....	D9/418
D. 332,744	1/1993	McCooley .....	D9/415
D. 335,257	5/1993	Hauber et al. ....	D9/431
D. 354,679	1/1995	Dunn .....	D9/415
D. 369,102	4/1996	Pare et al. ....	D9/415
1,911,678	5/1933	Dunn, Jr. .	
1,929,490	10/1933	Golden .....	206/44
2,401,908	6/1946	Calhoun et al. ....	206/44
2,617,578	11/1952	Fischer .....	229/16
2,701,089	2/1955	Fischer .....	229/16
2,979,192	4/1961	Blonder .	
3,517,801	6/1970	Cote .....	206/779
3,765,527	10/1973	Vargo .....	229/16 D
4,627,536	12/1986	Pugh .....	206/779
5,427,808	6/1995	Adams .....	426/419
5,860,526	1/1999	Burke, Jr. ....	206/775

## OTHER PUBLICATIONS

American Druggist, p. 23, circular bottles, Jan. 1983.

Primary Examiner—Lucy Lieberman

Attorney, Agent, or Firm—Sheldon & Mak

## [57] CLAIM

The ornamental design for packaging, as shown and described.

## DESCRIPTION

FIG. 1 is a perspective view of a first version of packaging according to the present invention, wherein the packaging comprises outer packaging and inside bottles..

FIG. 2 is a front elevation view of the packaging of FIG. 1.

FIG. 3 is a bottom plan view of the packaging of FIG. 1.

FIG. 4 is a top plan view of the packaging of FIG. 1.

FIG. 5 is a side elevation view of the packaging of FIG. 1,

taken on line 5—5 in FIG. 1, where the opposite side is not shown because it is a mirror image of the side shown in FIG. 5.

FIG. 6 is a rear elevation view of the packaging of FIG. 1.

FIG. 7 is a perspective view of the packaging of FIG. 1, without bottles.

FIG. 8 is a front elevation view of the packaging of FIG. 1, partially cut away to show the bottles.

FIG. 9 is a perspective view of a second version of packaging according to the present invention, wherein the packaging comprises outer packaging and an inside bottle.

FIG. 10 is a front elevation view of the packaging of FIG. 9.

FIG. 11 is a bottom plan view of the packaging of FIG. 9.

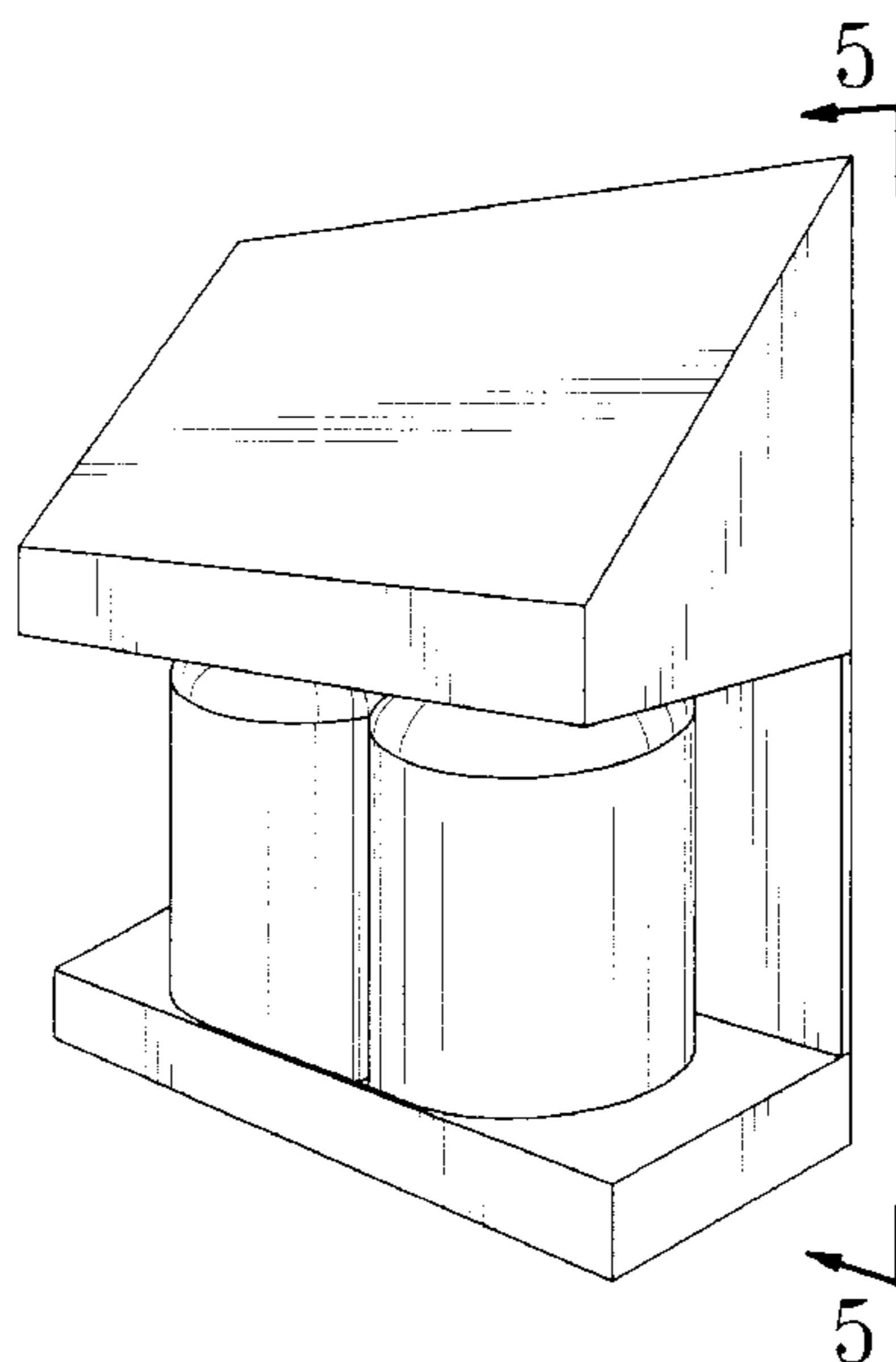
FIG. 12 is a top plan view of the packaging of FIG. 9.

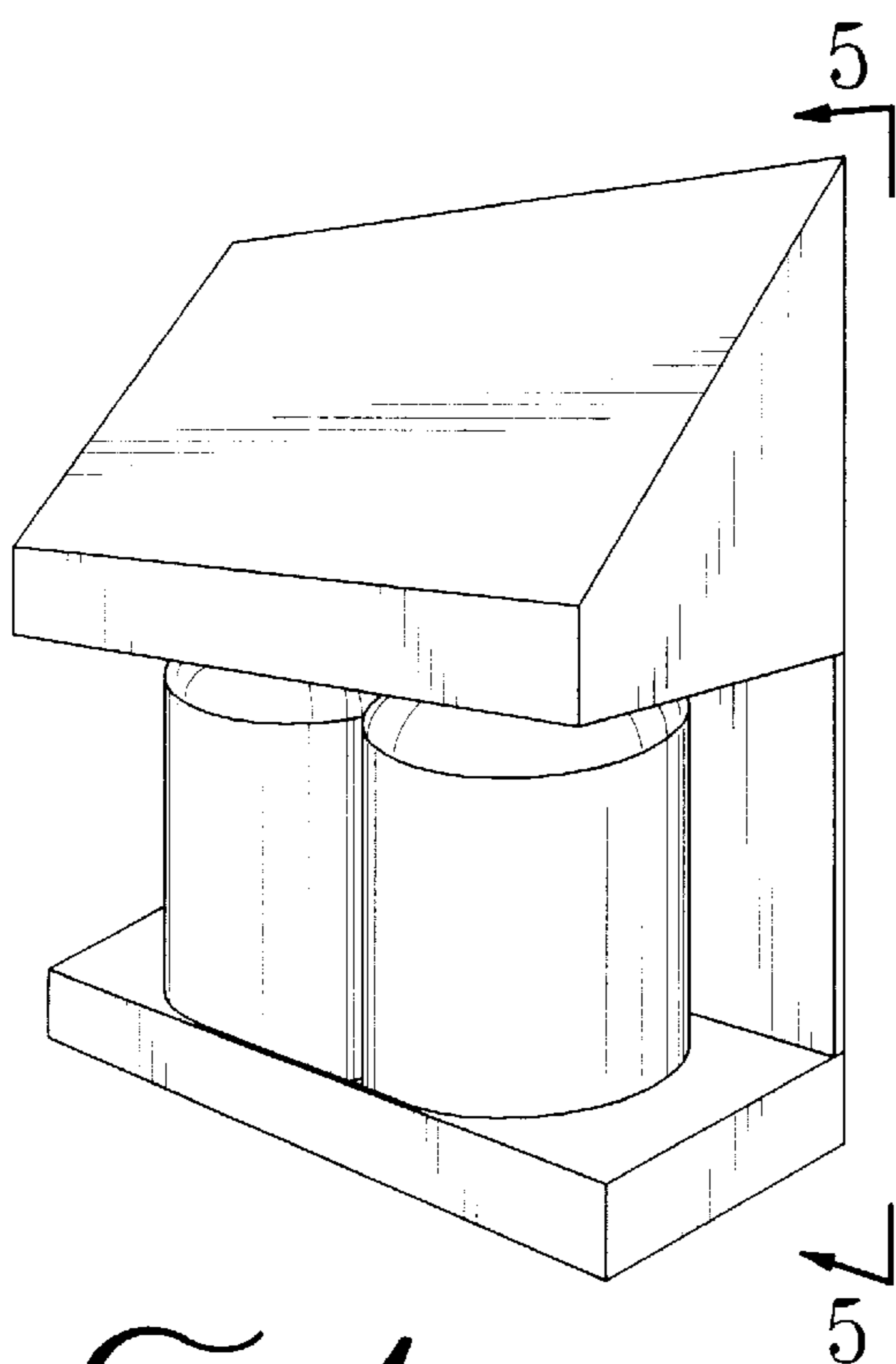
FIG. 13 is a side elevation view of the packaging of FIG. 9, taken on line 13—13 in FIG. 9 where the opposite side is not shown because it is a mirror image of the side shown in FIG. 9; and,

FIG. 14 is a rear elevation view of the packaging of FIG. 9.

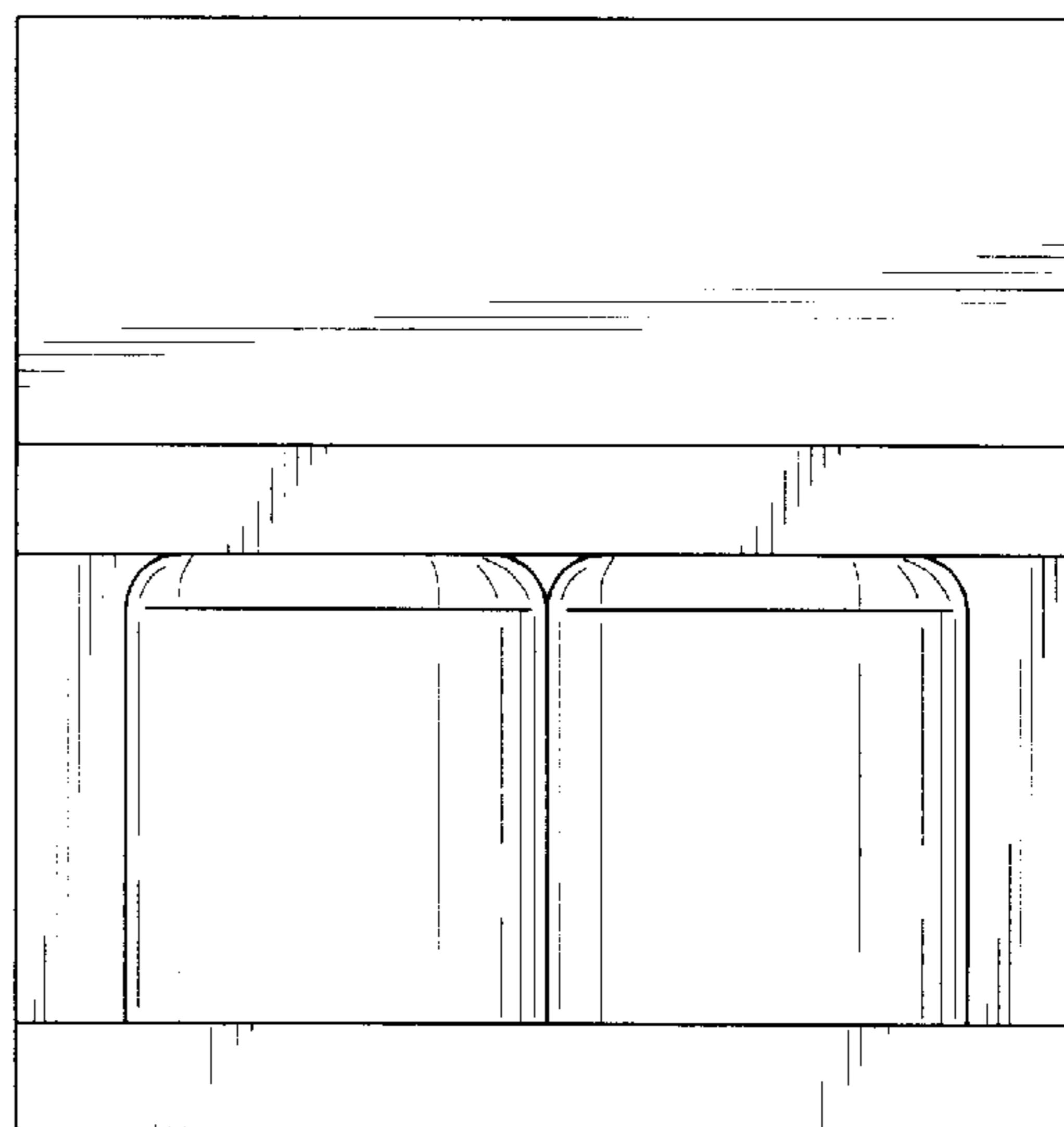
The display box is shown without the bottles in FIG. 7 for clarity of illustration.

1 Claim, 4 Drawing Sheets

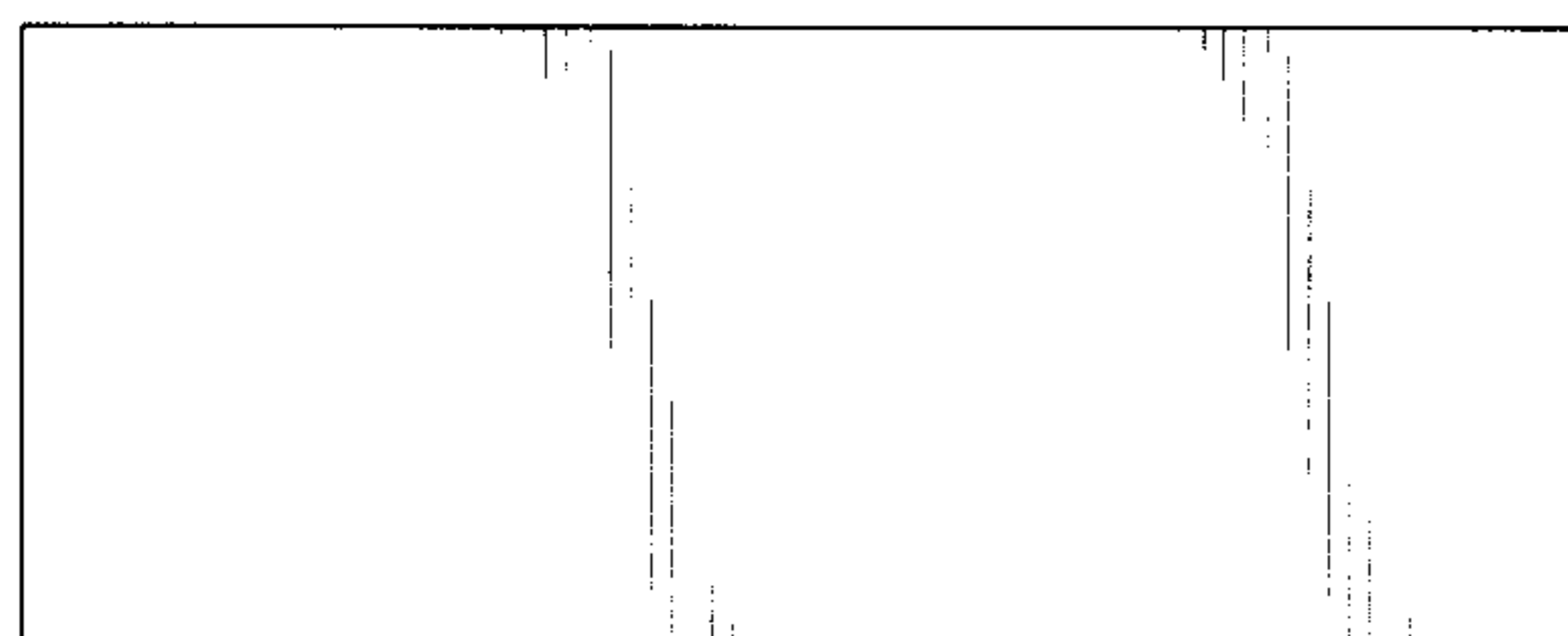




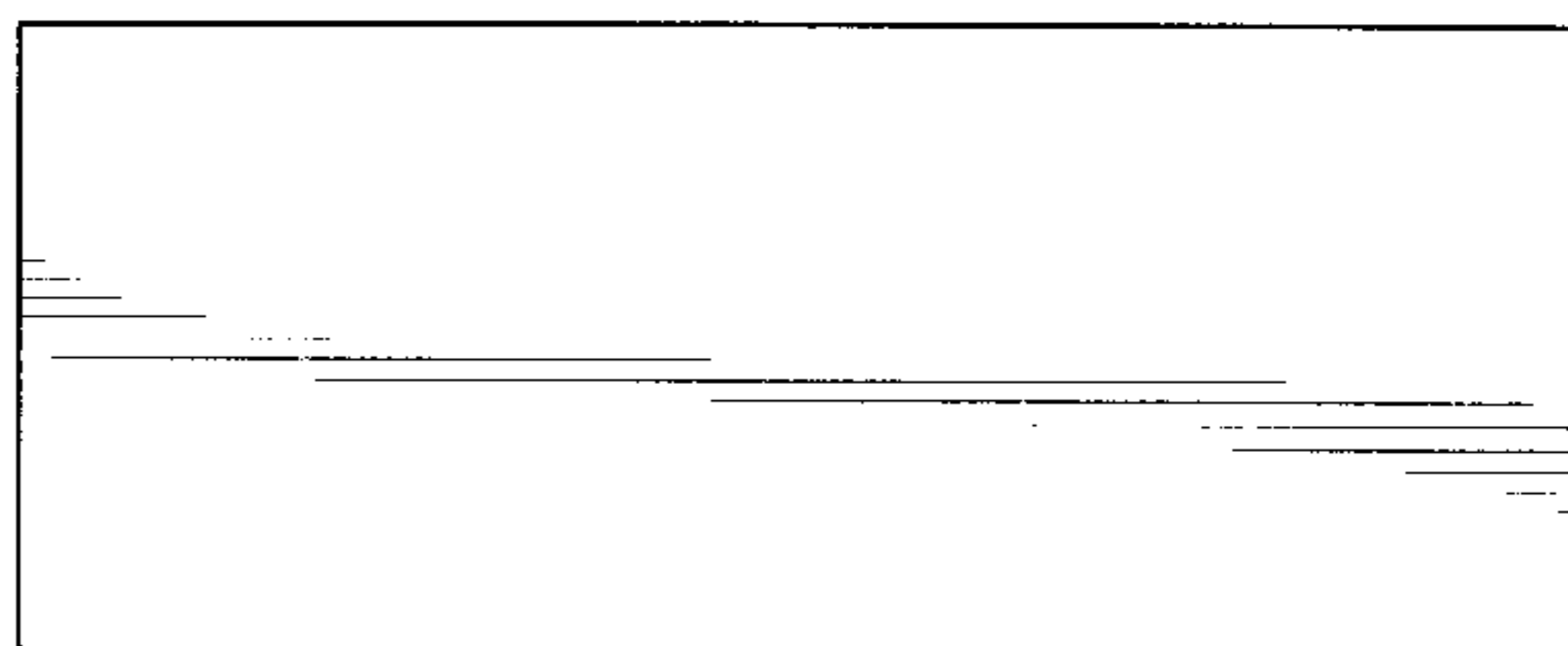
*FIG. 1*



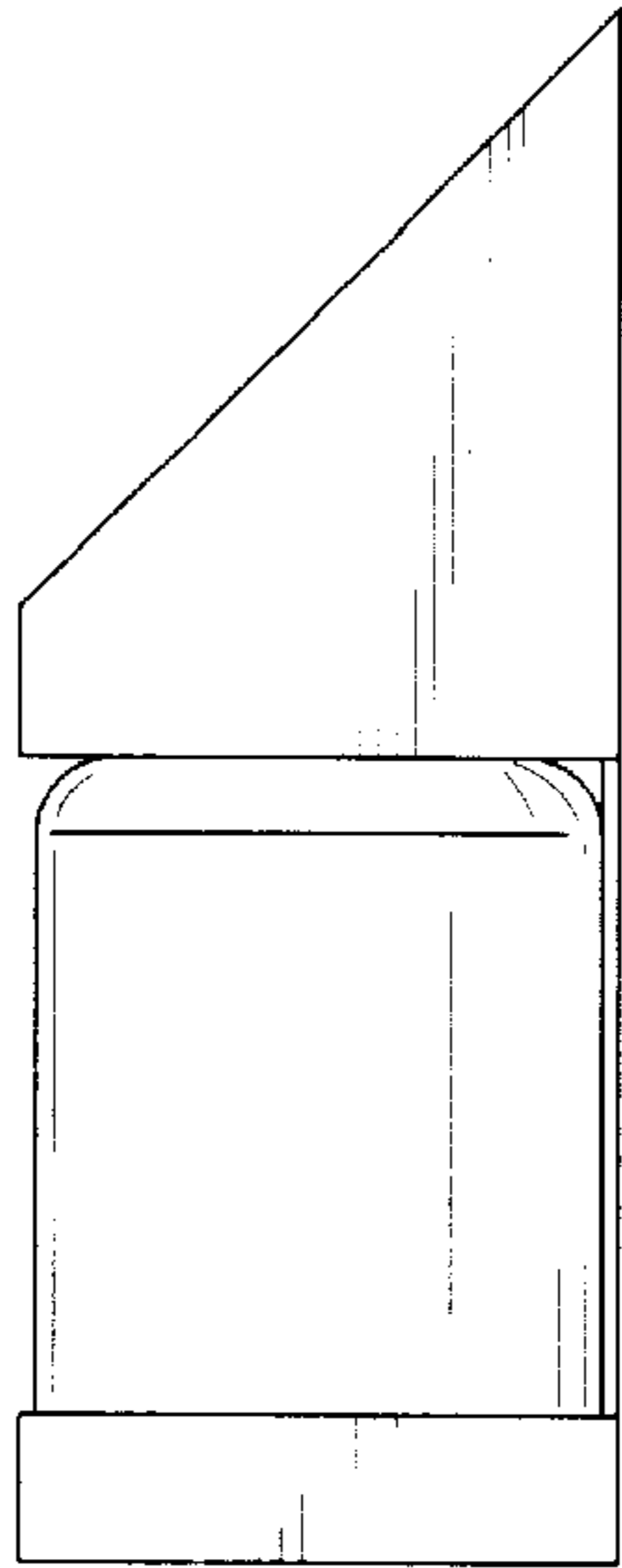
*FIG. 2*



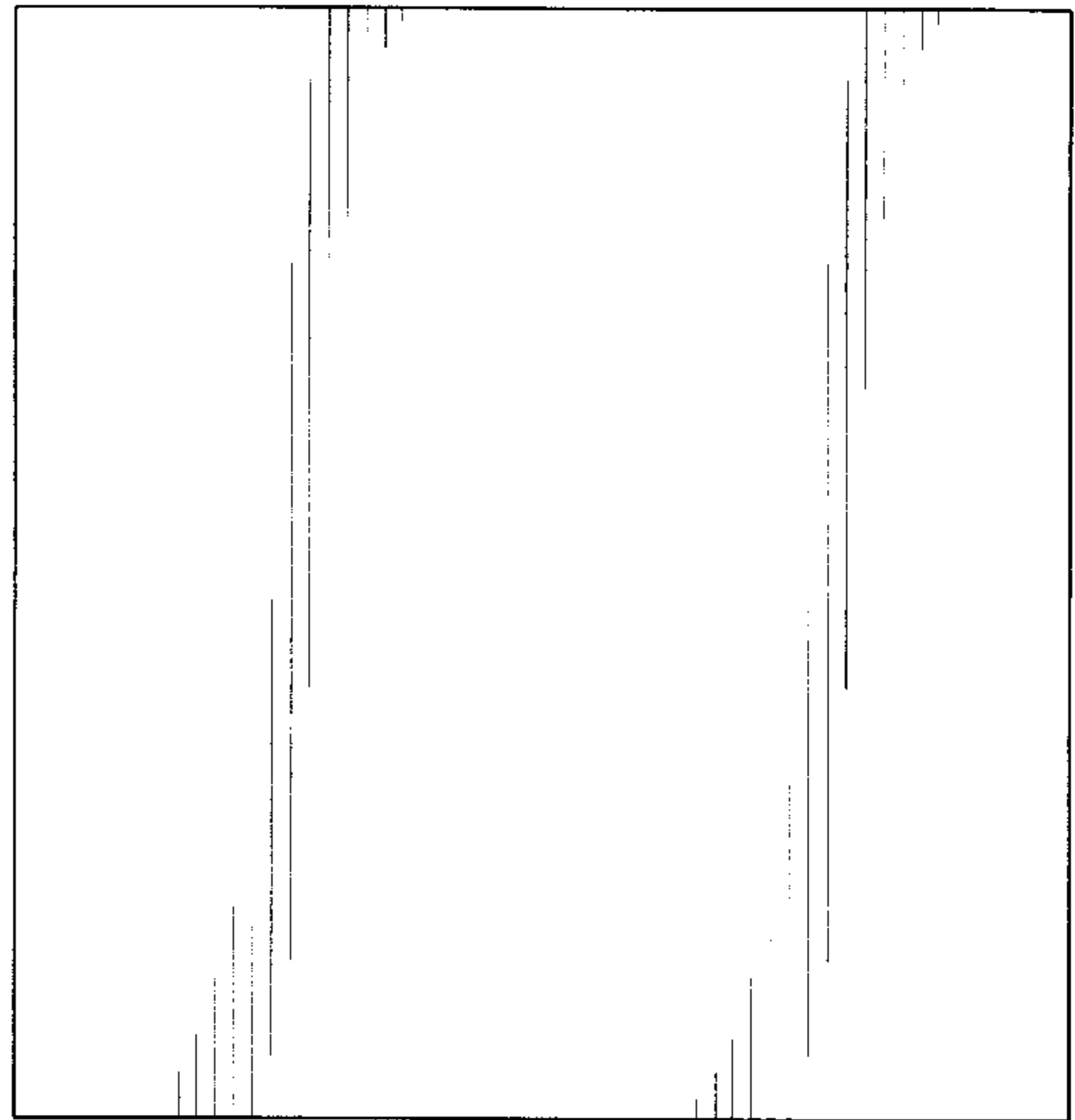
*FIG. 3*



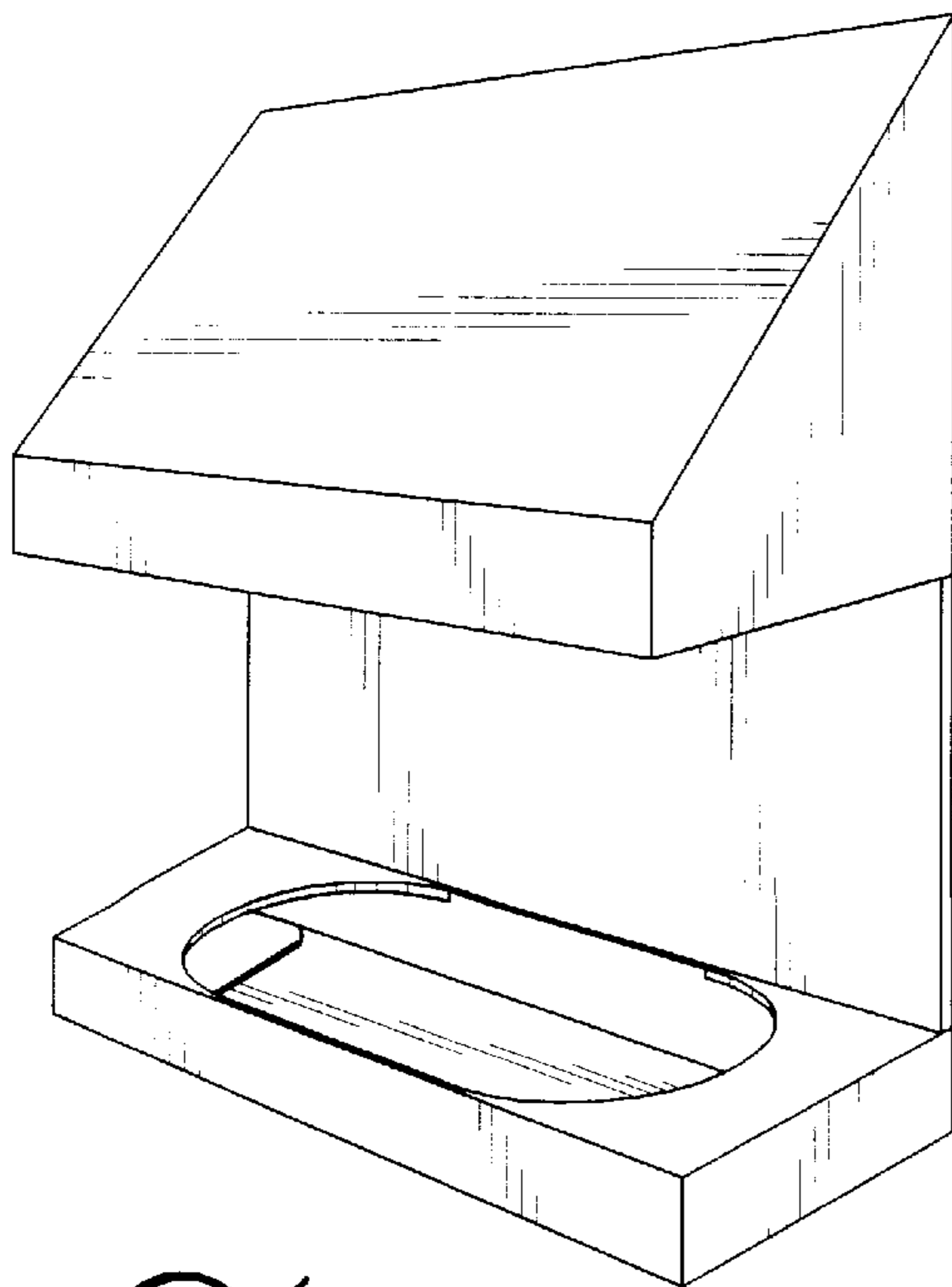
*FIG. 4*



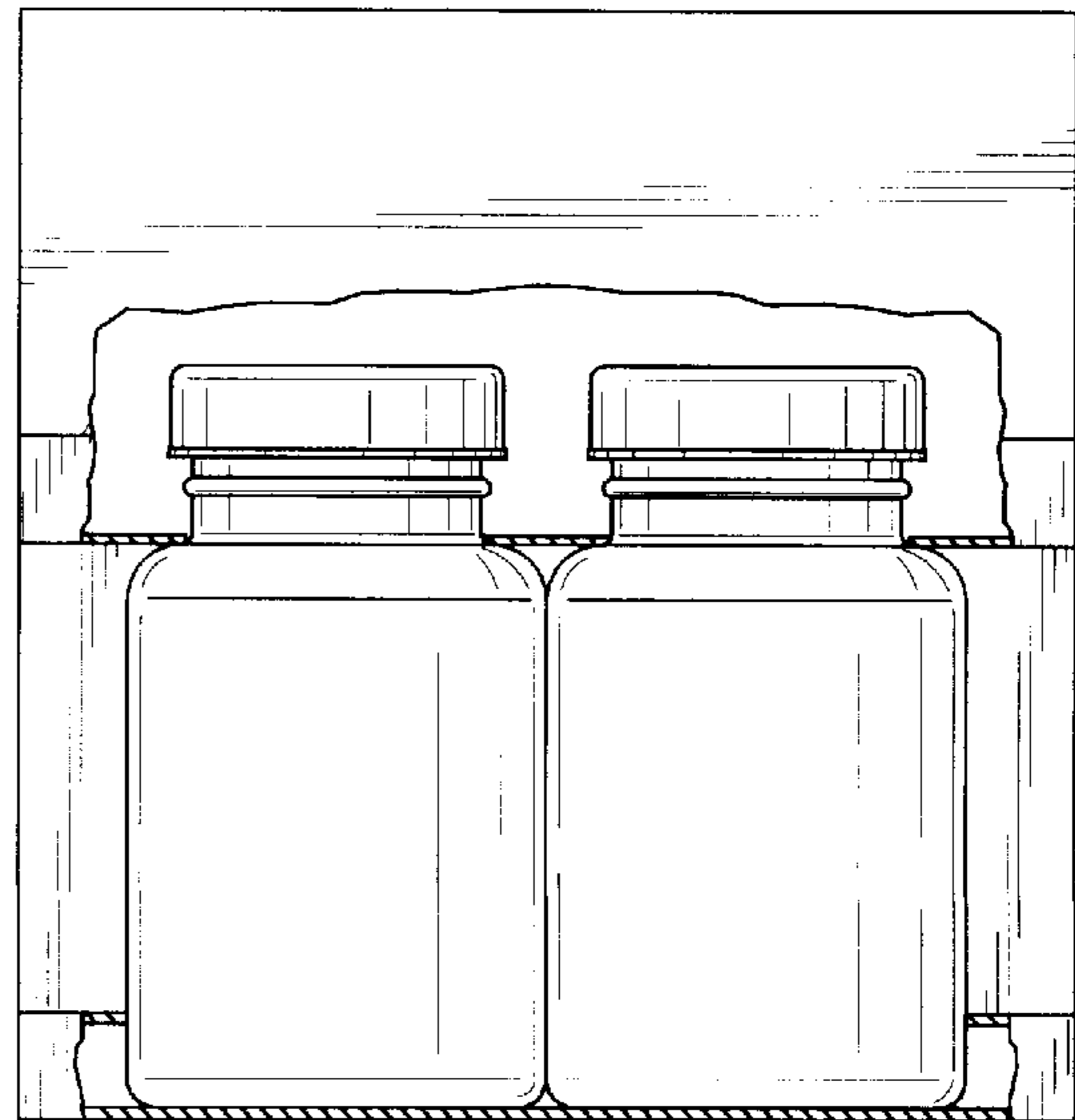
*FIG. 5*



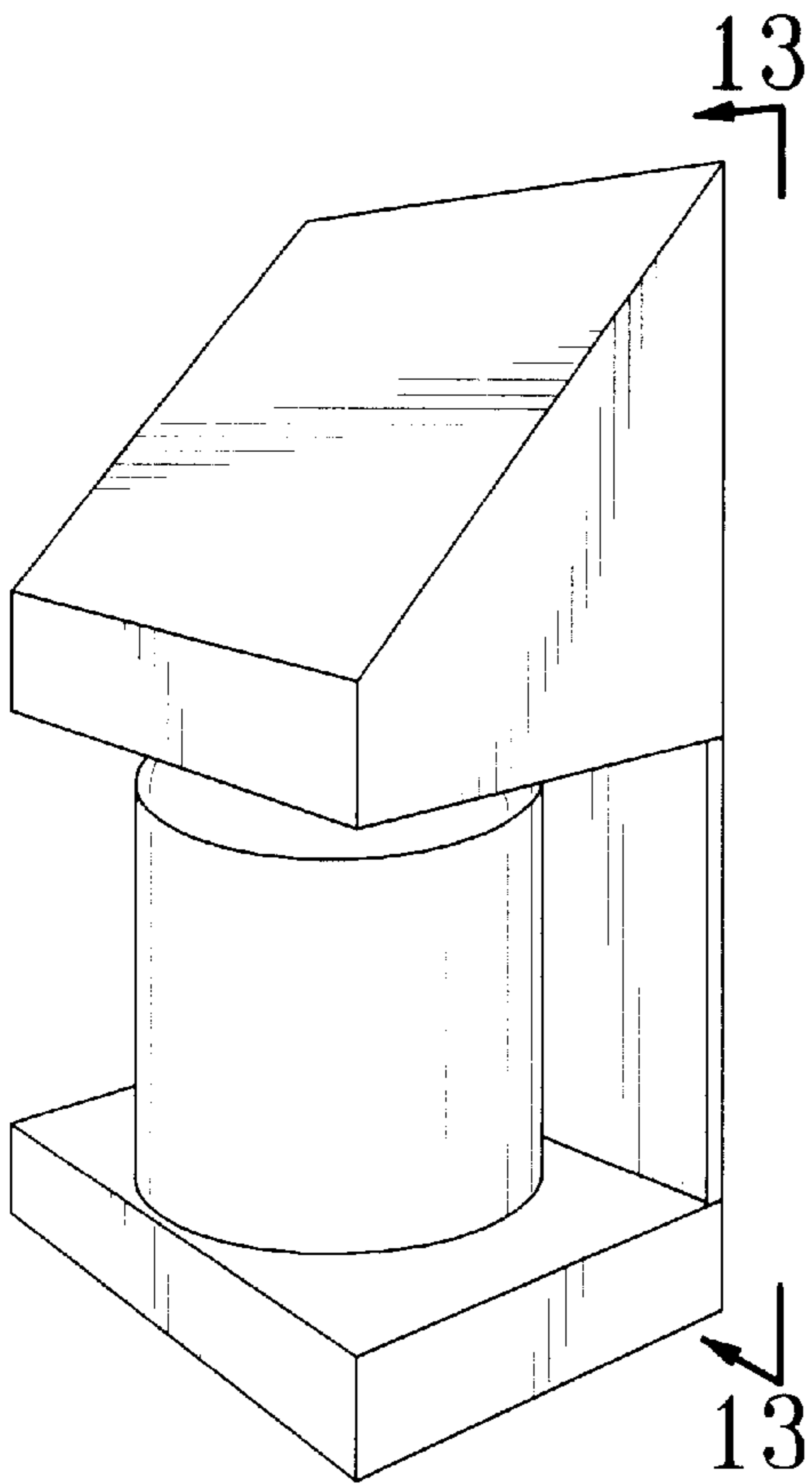
*FIG. 6*



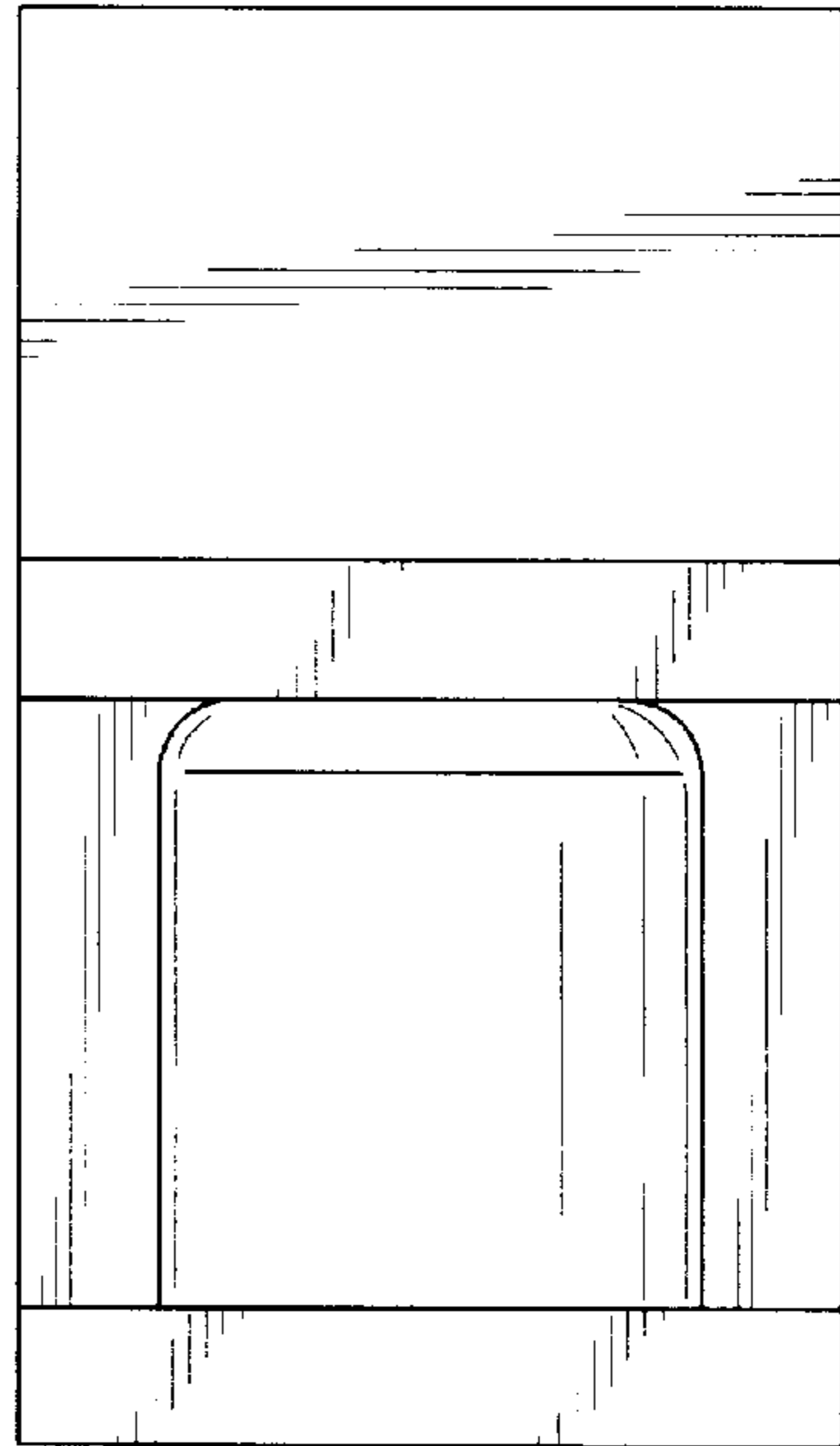
*FIG. 7*



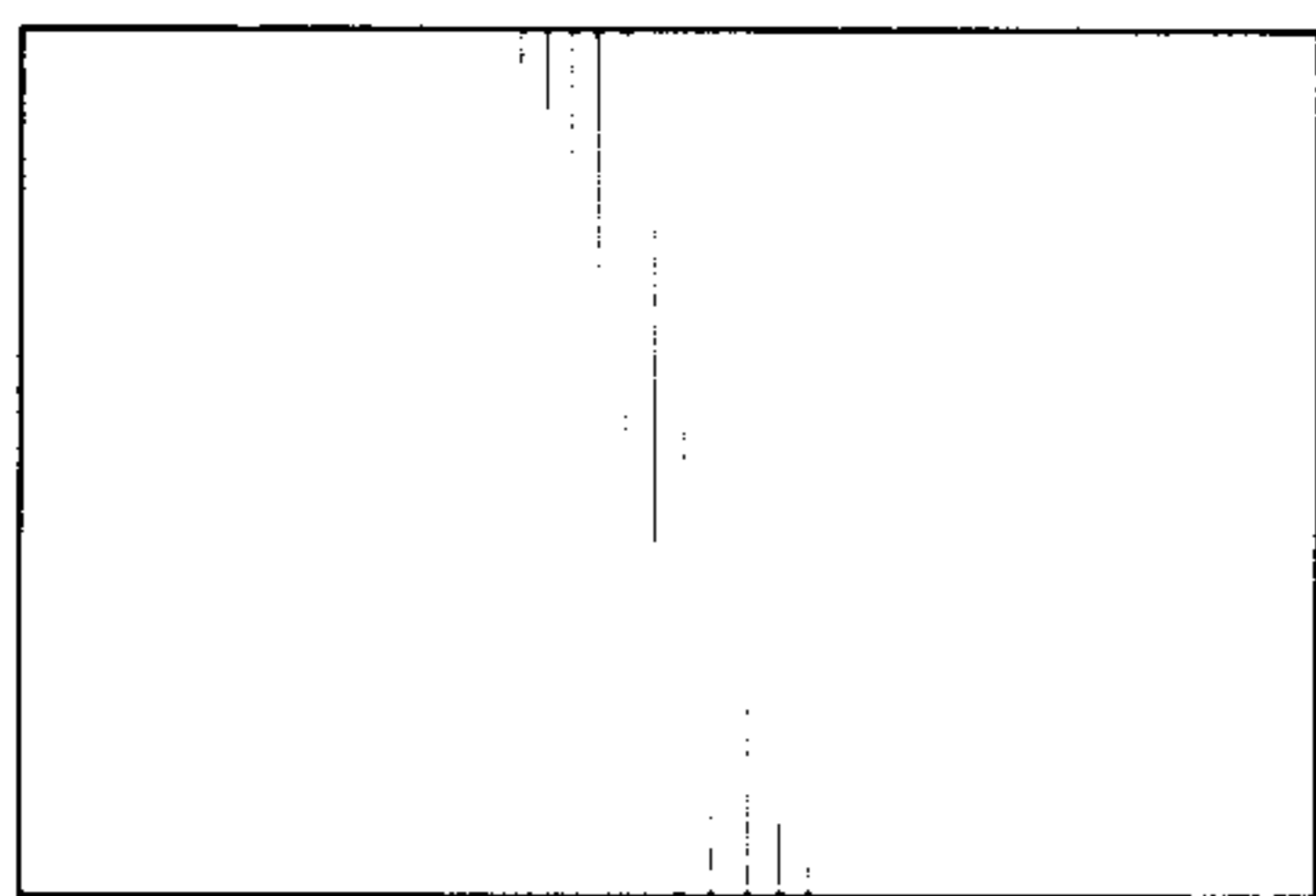
*FIG. 8*



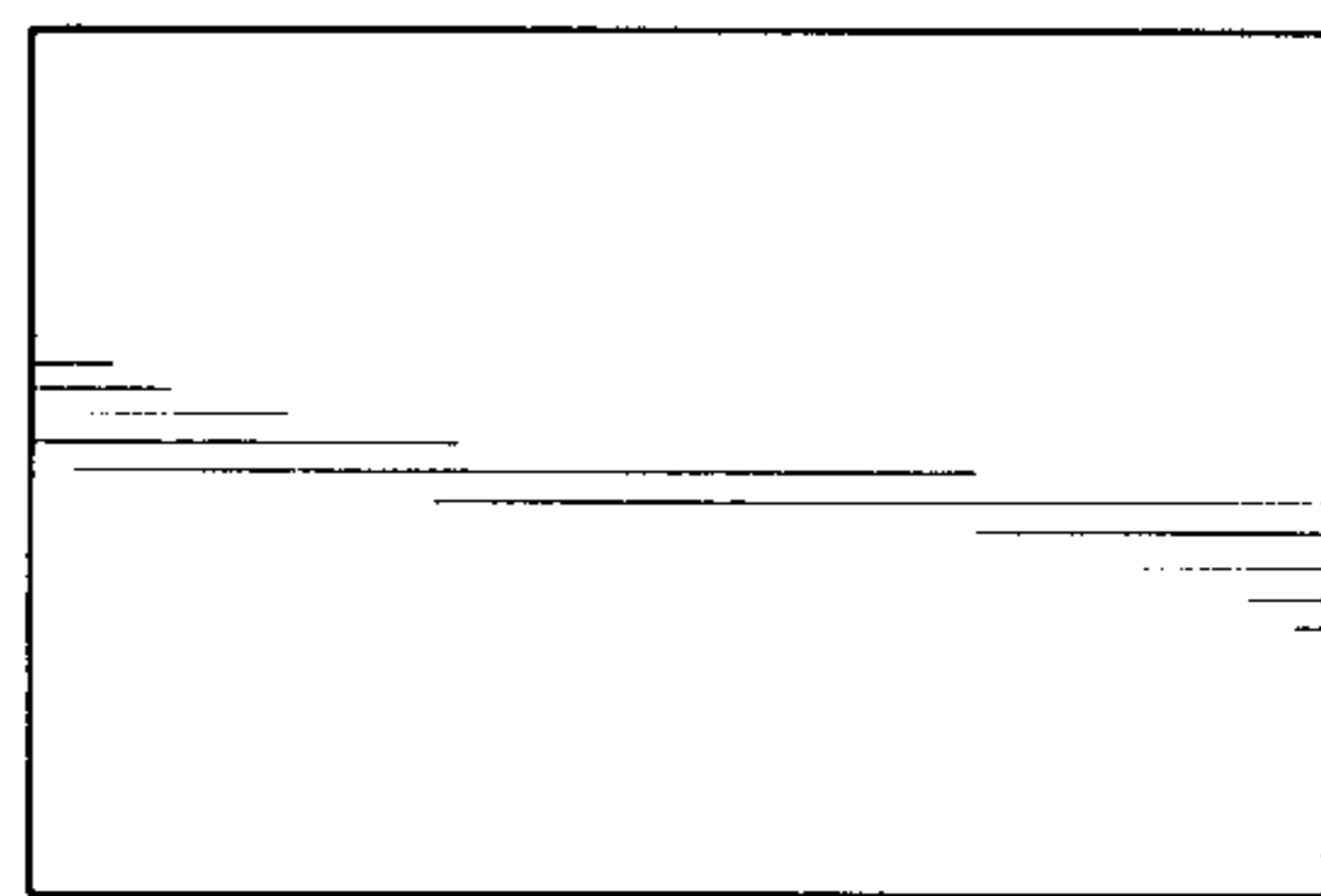
*FIG. 9*



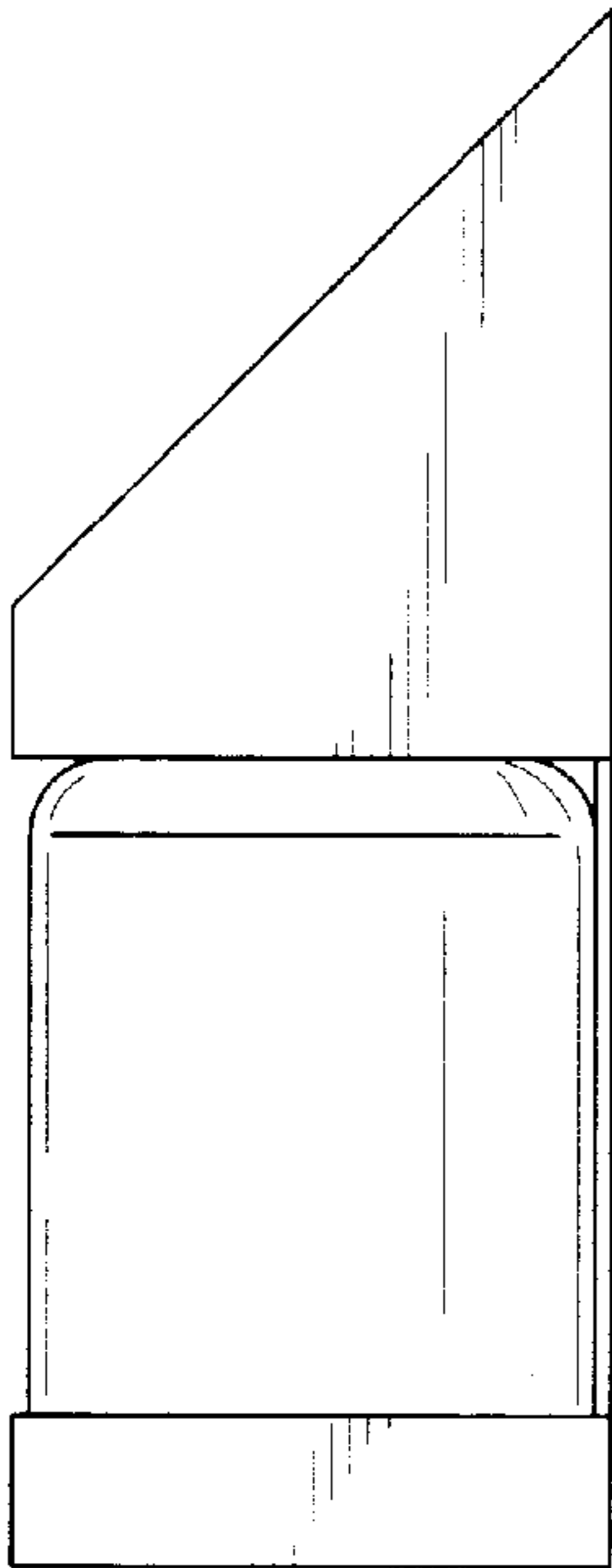
*FIG. 10*



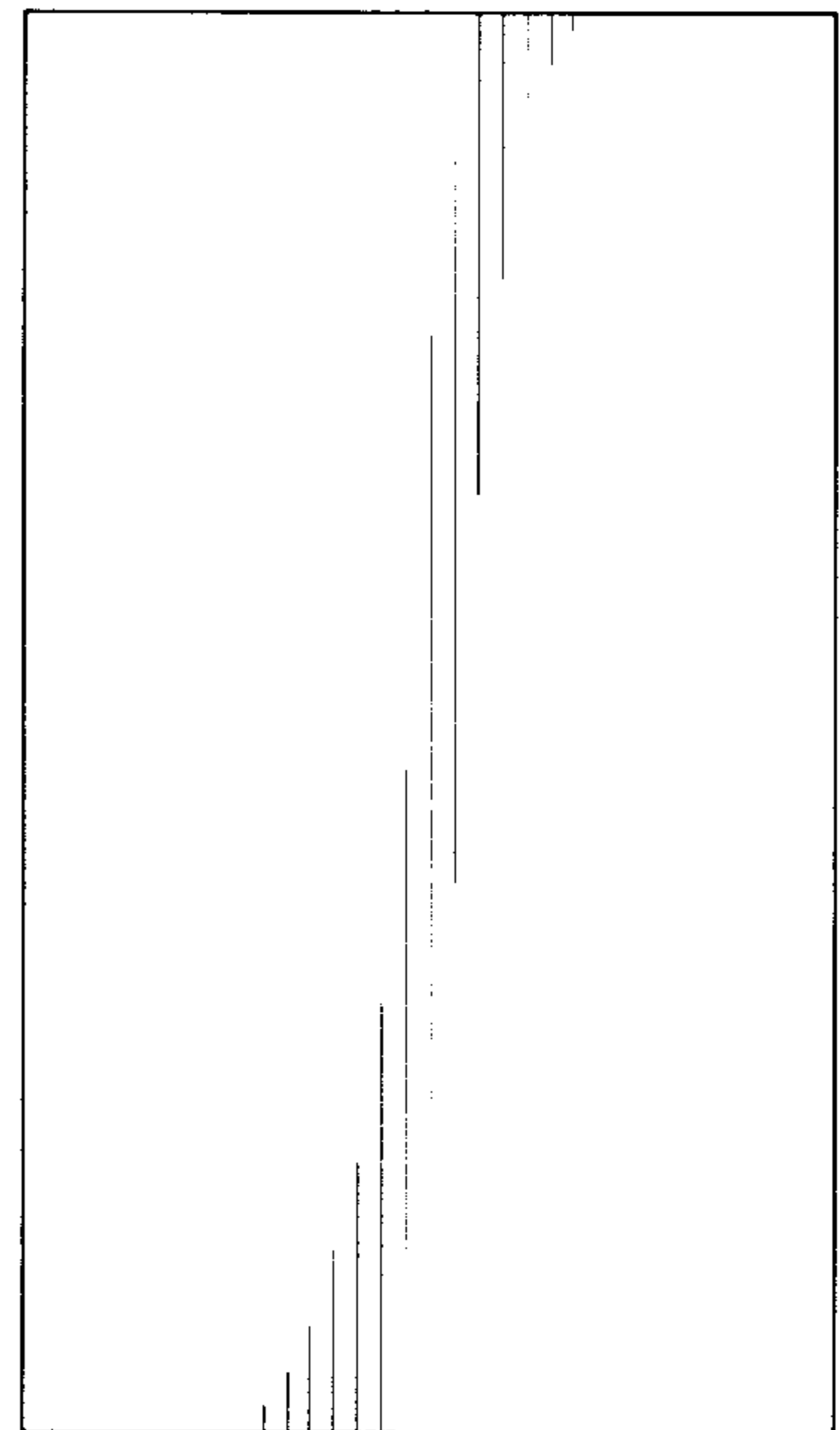
*FIG. 11*



*FIG. 12*



*FIG. 13*



*FIG. 14*