



US00D435407S

United States Patent [19]
Yager et al.

[11] **Patent Number: Des. 435,407**
[45] **Date of Patent: ** Dec. 26, 2000**

[54] **GARDEN TOOL**

[75] Inventors: **Thomas L. Yager**, Madison; **Paul R. Davis**, Ridgeway; **Mark A. McLean**, Fitchburg, all of Wis.

[73] Assignee: **Fiskars Inc.**, Madison, Wis.

[**] Term: **14 Years**

[21] Appl. No.: **29/115,360**

[22] Filed: **Dec. 13, 1999**

[51] **LOC (7) Cl.** **08-01**

[52] **U.S. Cl.** **D8/10**

[58] **Field of Search** D8/1, 10, 97, 107;
294/49, 57; 172/371

[56] **References Cited**

U.S. PATENT DOCUMENTS

32,327 5/1861 Wood .

(List continued on next page.)

OTHER PUBLICATIONS

Promotional advertisement for “Long—Reach Weeders for Raised Beds” in Gardener’s Supply Company, p. 21, bearing a designation “Summer 1999” (2 color sheets).

(List continued on next page.)

Primary Examiner—Robin V. Taylor
Attorney, Agent, or Firm—Foley & Lardner

[57] **CLAIM**

We claim the ornamental design for a garden tool, as shown and described.

DESCRIPTION

FIG. 1 is a perspective view of a garden tool showing our new design;
FIG. 2 is a top view thereof;
FIG. 3 is a right side view thereof;
FIG. 4 is a bottom view thereof;
FIG. 5 is a front elevational view thereof;
FIG. 6 is a rear elevational view thereof;

FIG. 7 is a perspective view of an alternative embodiment of a garden tool;
FIG. 8 is a top view of the embodiment shown in FIG. 7;
FIG. 9 is a right side view of the embodiment shown in FIG. 7;
FIG. 10 is a rear elevational view of the embodiment shown in FIG. 7;
FIG. 11 is a perspective view of an alternative embodiment of the invention;
FIG. 12 is a right side view of the embodiment shown in FIG. 11;
FIG. 13 is a rear elevational view of the embodiment shown in FIG. 11;
FIG. 14 is a perspective view of an alternative embodiment of a garden tool;
FIG. 15 is a top view of the embodiment shown in FIG. 14;
FIG. 16 is a right side view of the embodiment shown in FIG. 14;
FIG. 17 is a bottom view of the embodiment shown in FIG. 14;
FIG. 18 is a front elevational view of the embodiment shown in FIG. 14;
FIG. 19 is a rear elevational view of the embodiment shown in FIG. 14;
FIG. 20 is a perspective view of an alternative embodiment of the invention;
FIG. 21 is a top view of the embodiment shown in FIG. 20;
FIG. 22 is a right side view of the embodiment shown in FIG. 20;
FIG. 23 is a rear elevational view of the embodiment shown in FIG. 20;
FIG. 24 is a perspective view of an alternative embodiment of the invention;
FIG. 25 is a right side view of the embodiment shown in FIG. 24;
FIG. 26 is a rear elevational view of the embodiment shown in FIG. 24;
FIG. 27 is a perspective view of the embodiment shown in FIG. 20; and,
FIG. 28 is a perspective view of the embodiment shown in FIG. 20.

The ornamental design which is claimed is shown in solid lines in the drawings. The broken lines in the drawings are for illustrative purposes only and form no part of the claimed design.

1 Claim, 9 Drawing Sheets

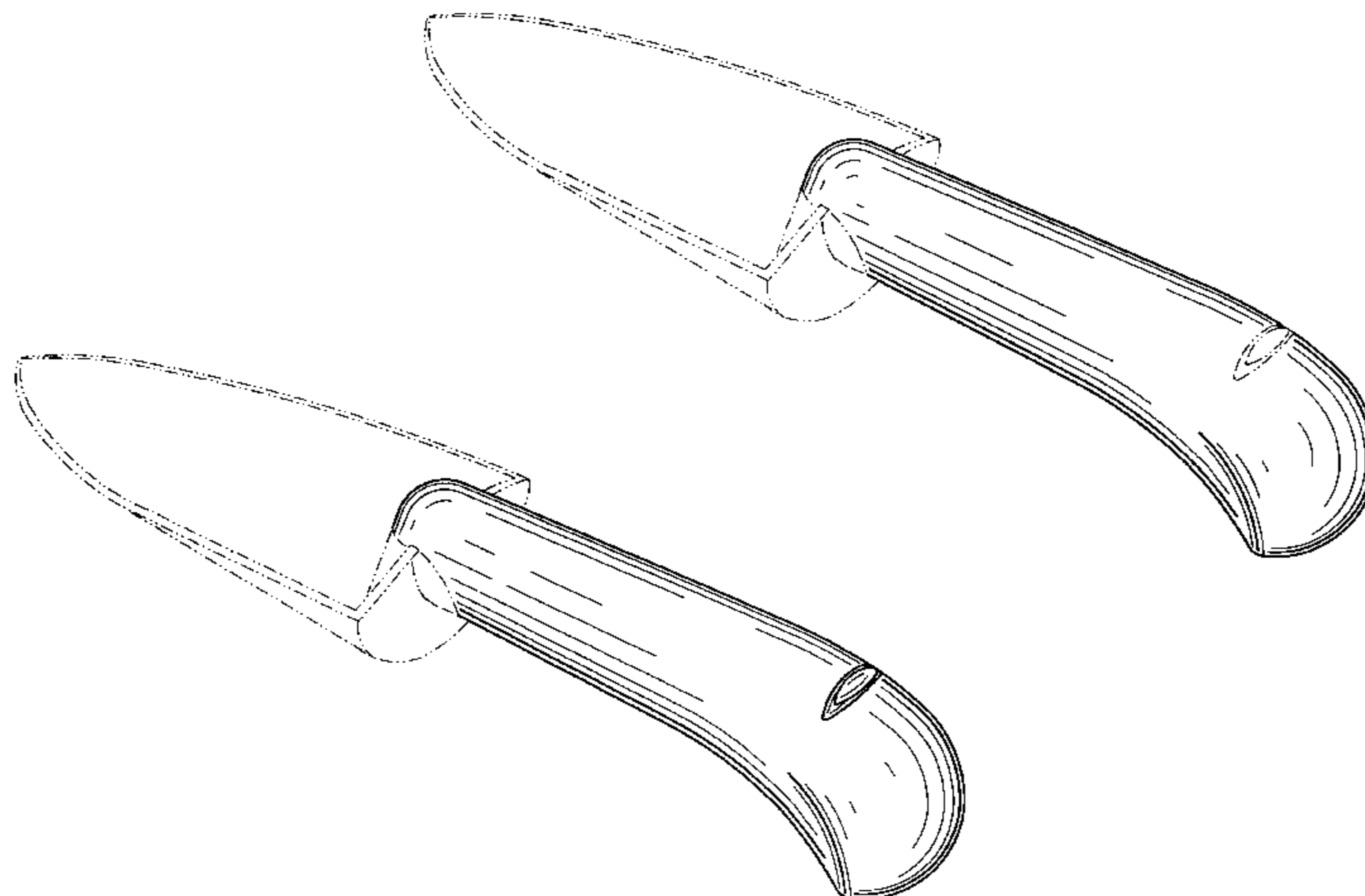

U.S. PATENT DOCUMENTS

160,464	3/1875	Peabody .	
D. 191,751	11/1961	Woodall	D34/5
D. 280,173	8/1985	Welch	D7/152
D. 292,865	11/1987	Scott	D8/10
D. 295,013	4/1988	Vosbikian	D8/10
D. 303,748	10/1989	Yamagishi	D7/152
D. 318,602	7/1991	Vosbikian	D8/10
D. 323,095	1/1992	Usbeck	D7/395
D. 338,378	8/1993	Concari	D8/10
D. 341,761	11/1993	Weimann	D8/97
D. 349,222	8/1994	Lindén et al.	D8/10
D. 353,085	12/1994	Choi	D8/10
D. 354,661	1/1995	Lindén et al.	D8/10
D. 365,257	12/1995	Huang	D8/10
D. 378,345	3/1997	Austin et al.	D8/107
D. 378,798	4/1997	Berti	D8/107
D. 383,049	9/1997	Concari et al.	D8/10
D. 387,649	12/1997	Concari et al.	D8/107
D. 407,267	3/1999	Juhlin et al.	D8/107
646,048	3/1900	Donzella .	
2,550,874	5/1951	Skoog	30/190
2,602,994	7/1952	McGary et al.	30/251
3,039,189	6/1962	McBerty	30/245
5,084,975	2/1992	Melter	30/249
5,293,878	3/1994	Bales et al.	128/751
5,317,806	6/1994	Held et al.	30/249
5,347,800	9/1994	Morgan	56/335

OTHER PUBLICATIONS

Promotional advertisement for “Gardener’s Supply Innovation” in Gardener’s Supply Company, p. 26, bearing a designation “Summer 1999” (2 color sheets).

Promotional advertisement for “Total Plant Health” in Gardener’s Supply Company, p. 65, bearing a designation “Summer 1999” (2 color sheets).

Promotional advertisement for “Power Gear Loppers Perform Heavyweight Jobs” in Gardener’s Supply Company, p. 33, bearing a designation “Summer 1999” (2 color sheets).

Promotional advertisement for “Die–Cast Solid Aluminum Garden Tools Have Comfortable Soft Grips” in Hard–To–Find Tools, Brookstone, p. 3, undated (2 color sheets).

Promotional advertisement for “16Piece Garden Tool Set Provides All the Basics At A Fraction of the Cost” in Hard–To–Find Tools—Brookstone, p. 5, undated (2 color sheets).

Promotional advertisement for “New! Stainless Steel Head Design Will Make This Carpenter’s Hammer the Best You’ve Ever Tried” in Hard–To–Find Tools—Brookstone, p. 55, undated (2 color sheets).

Graphical Internet image, available at http://www.westons.com/hhimages/hhol_1.jpg, bearing a designation “Apr. 17, 2000” (1 color sheet).

Graphical Internet image, available at http://www2.prestel.co.vk/phoghes/hh98images/hh98_01_2.jpg, bearing a designation “Apr. 17, 2000” (1 color sheet).

Garden.com, Internet web page “Garden.com Large Plant Product Page”, available at [http://www4.garden.com/cgi-bin/v2/gemug/Pl . . . 559835222623214025,149045=6343.sku=303654](http://www4.garden.com/cgi-bin/v2/gemug/Pl...559835222623214025,149045=6343.sku=303654), bearing a designation of “Apr. 17, 2000” (1 color sheet).

Garden.com, Internet web page “Garden.com Product Page”, available at [http://www4.garden.com/cgi-bin/v2/ge-plant/ . . . 559835222623214025,15563&Common_SKU=256031](http://www4.garden.com/cgi-bin/v2/ge-plant/. . . 559835222623214025,15563&Common_SKU=256031), bearing a designation of “Apr. 17, 2000” (1 color sheet).

Garden.com, Internet web page “Garden.com Product Page”, available at [http://www4.garden.com/cgi-bin/v2/ge-plant/ . . . 559835222623214025,16058&Common_SKU=256031](http://www4.garden.com/cgi-bin/v2/ge-plant/. . . 559835222623214025,16058&Common_SKU=256031), bearing a designation of “Apr. 17, 2000” (1 color sheet).

Garden.com, Internet web page “Garden.com Product Page”, available at [http://www4.garden.com/cgi-bin/v2/ge-plant/ . . . 559835222623214025,16508&Common_SKU=256020](http://www4.garden.com/cgi-bin/v2/ge-plant/. . . 559835222623214025,16508&Common_SKU=256020), bearing a designation of “Apr. 17, 2000” (one color sheet).

Promotional advertisement for “Corona Comfort Tools” in Rosie’s Tool Box, p. 5, bearing a designation “Fall 1999” (2 color sheets).

Promotional advertisement for “Gardening..” in Rosie’s Tool Box, p. 12, bearing a designation “Fall 1999” (2 color sheets).

Promotional advertisement for “High Quality Garden Tools & Accessories” by The Rumford Gardener, undated (1 color sheet).

Promotional advertisement for “Give The Gift of Kings” in Gardener’s Supply Company, pp. 4–5, bearing a designation of “Holiday Gifts from the Garden—1993–” (3 color sheets).

Promotional advertisement for “Heirloom–Quality Tools to Delight The Avid Gardener” in Gardener’s Supply Company, p. 58, bearing a designation of “Holiday Gifts from the Garden—1999–” (2 color sheets).

Promotional catalog by Bellota, pp. 29, 64 and 65, undated (4 color sheets).

Promotional advertisement for Birdland Lawn & Garden, p. 6, bearing a designation “Manufacturing Garden Products Since 1968”(2 sheets).

Promotional advertisement for Birdland Lawn & Garden, pp. 6–8, 12, undated (5 sheets).

Promotional catalog by Garden & Decorator Wood Products Inc., pp. 36–37 and 40–41, undated (6 sheets).

Promotional catalog by Birdland, p. 19 and unnumbered pages, bearing a designation “Manufacturing Garden Products Since 1968” (5 sheets).

Promotional advertisement for Birdland Industries Inc., undated (2 sheets).

Promotional catalog by Shang Gu Enterprise Co. Ltd., pp. 18–21, bearing a designation “Sep. 5, 1997” and “Jun. 1, 1998” (7 sheets).

Promotional catalog by Eckman International Ltd., undated (2 sheets).

Promotional catalog “2000 Lawn & Garden Catalog” by Fiskars Inc., pp. 20–21, bearing a designation “2000” (3 color sheets).

Horticulture, “Quality Garden Tools for Serious Gardeners”, p. 79, bear a designation “Apr. 2000” (2 color sheets).

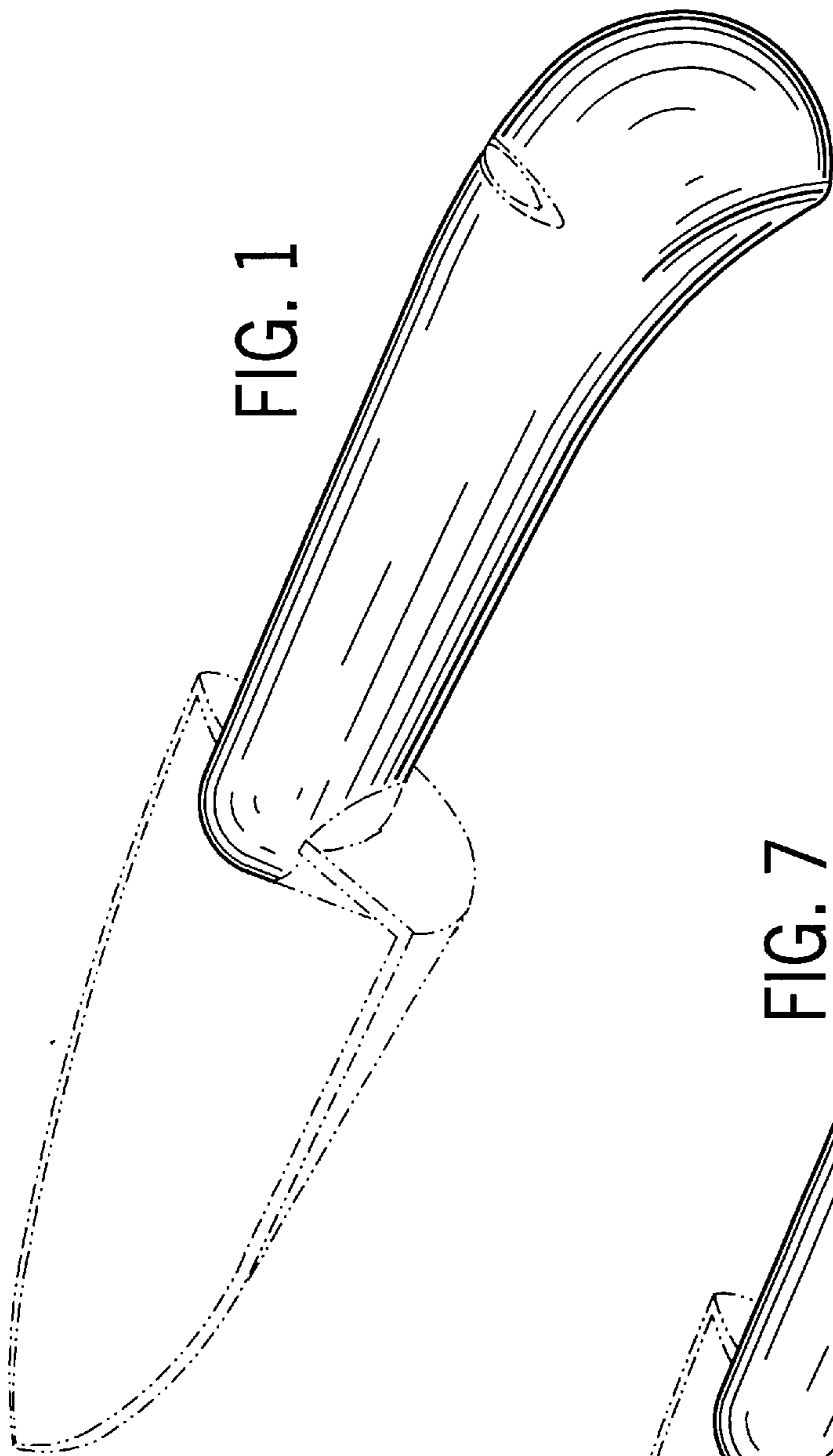

FIG. 1

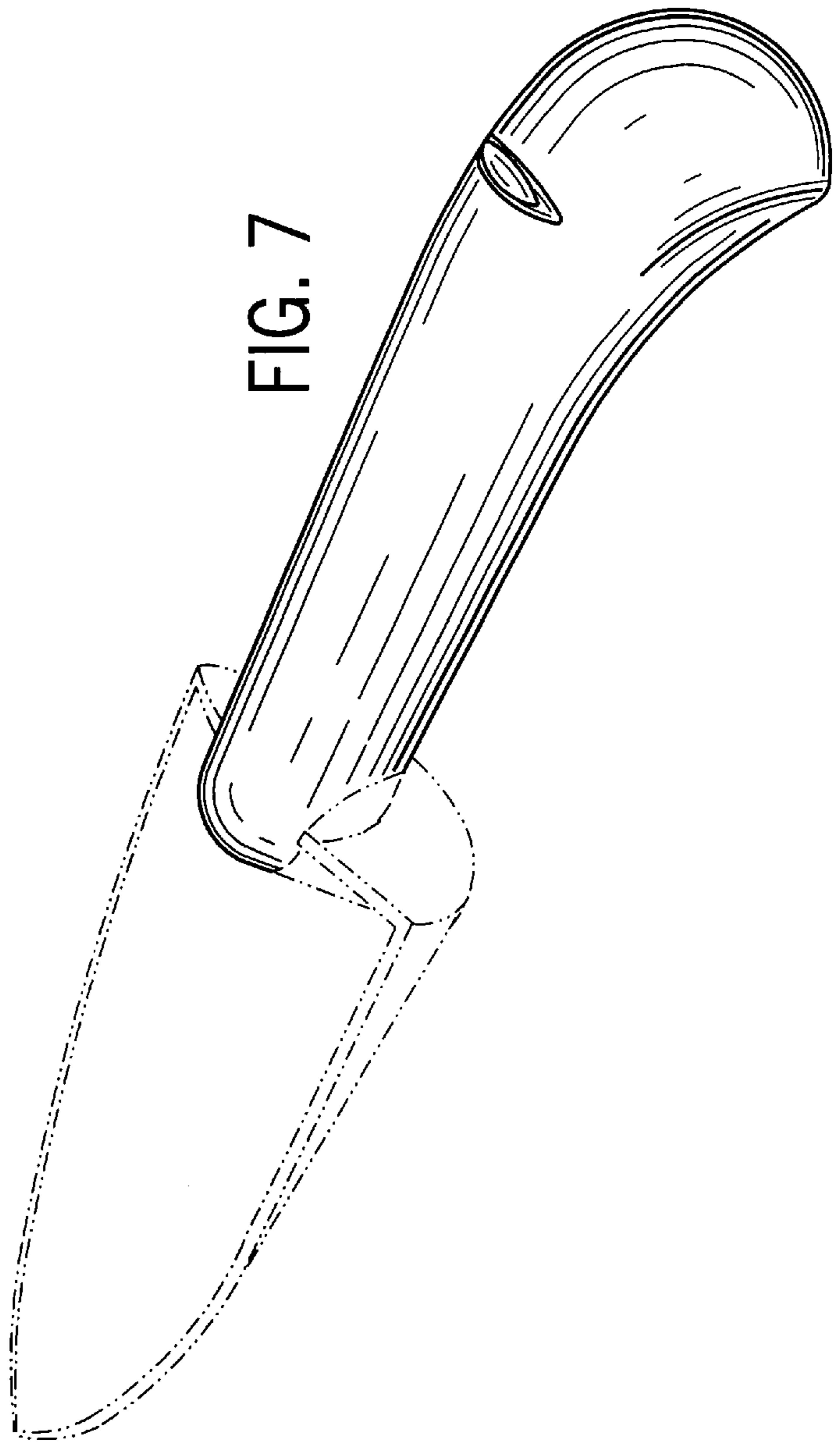
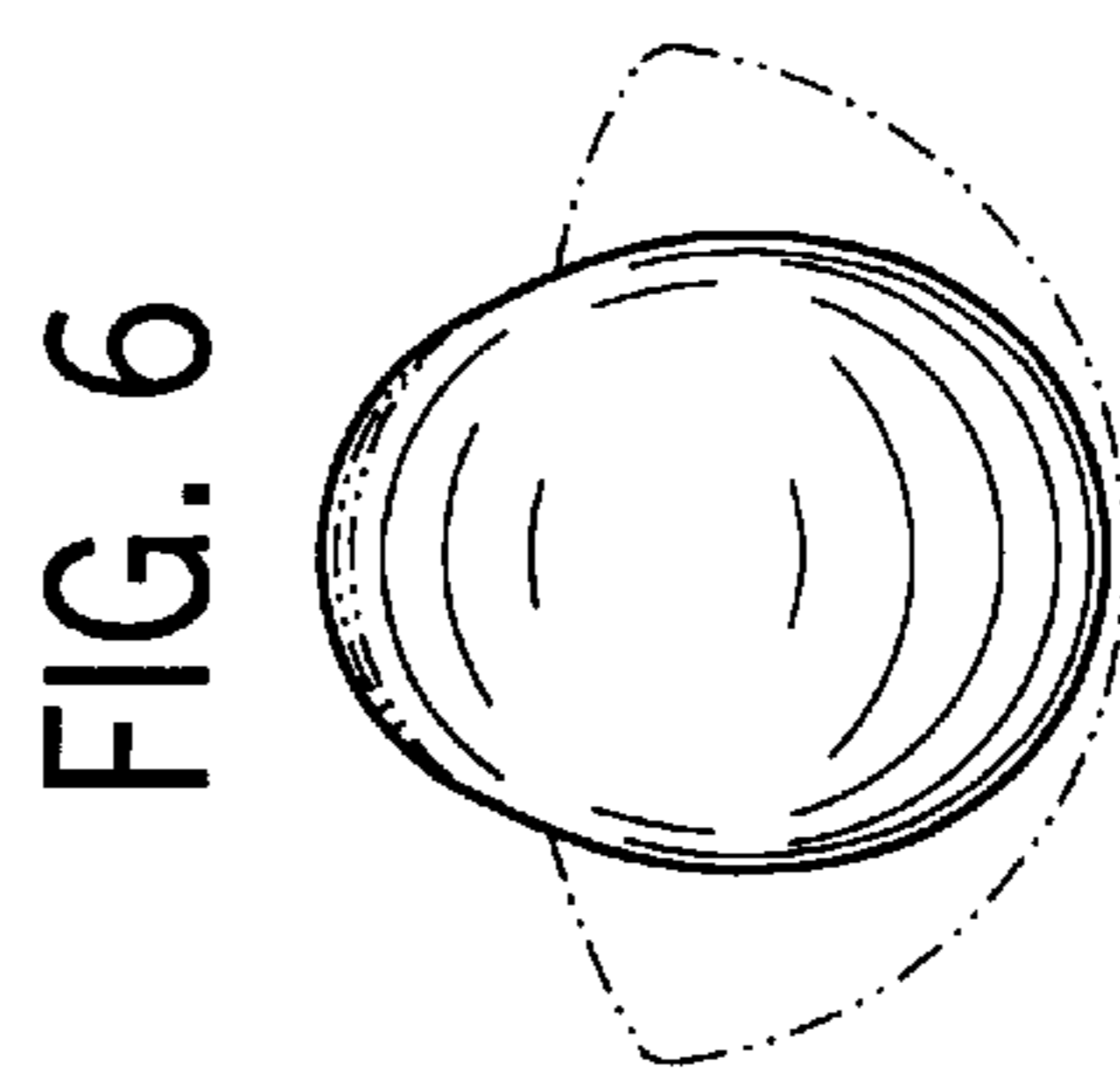
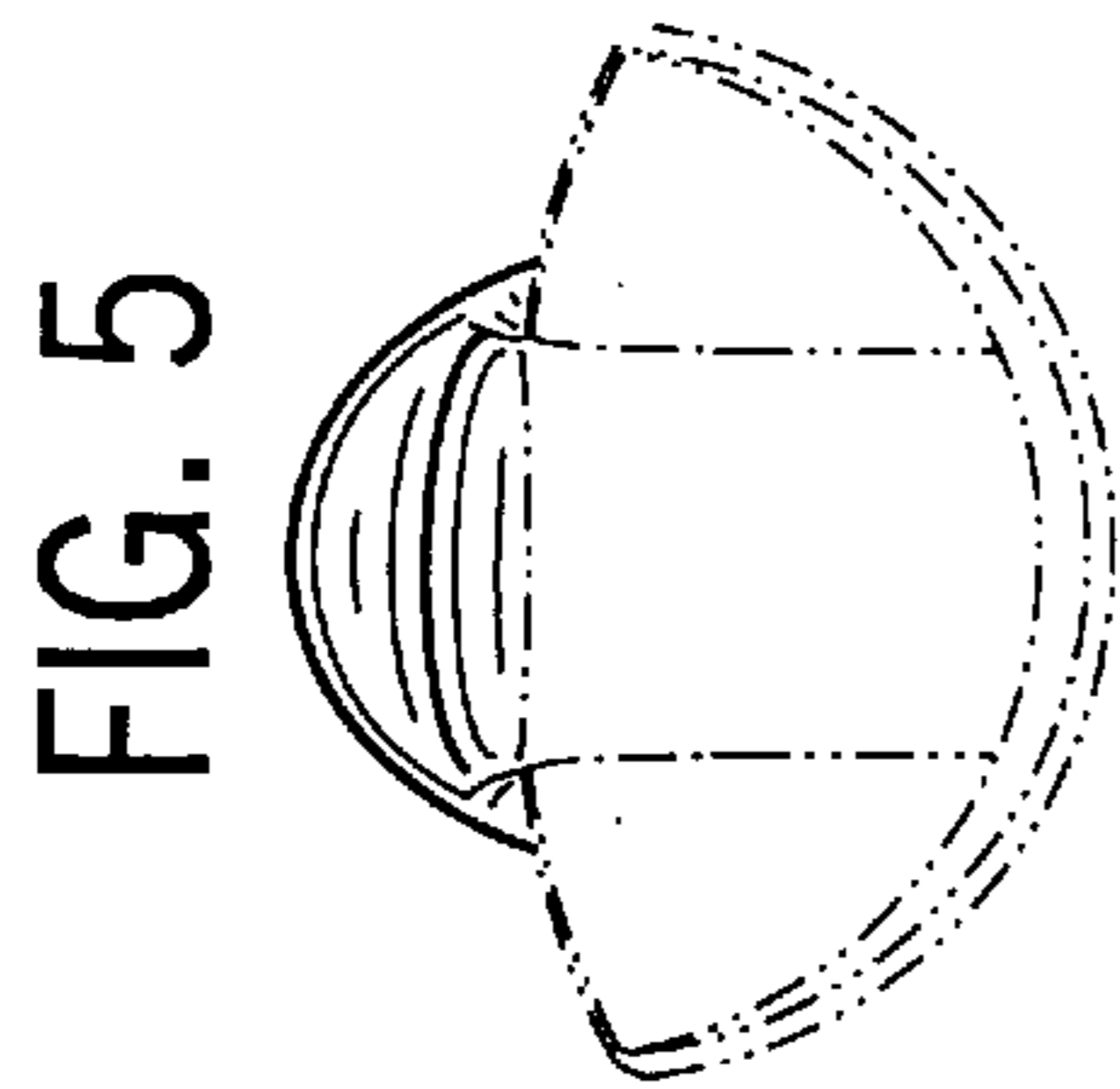
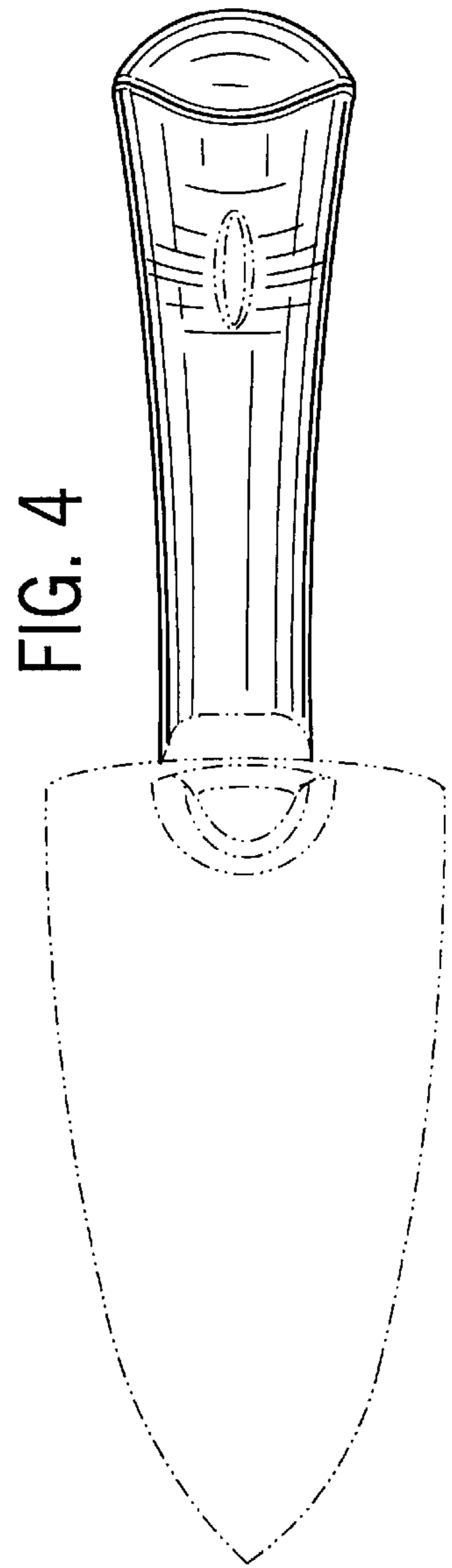
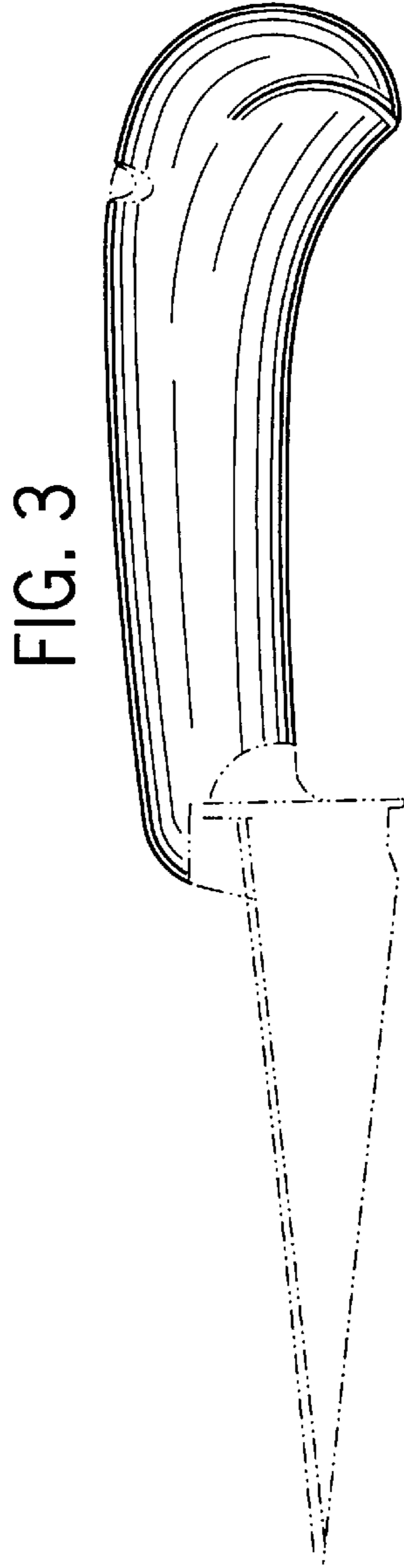
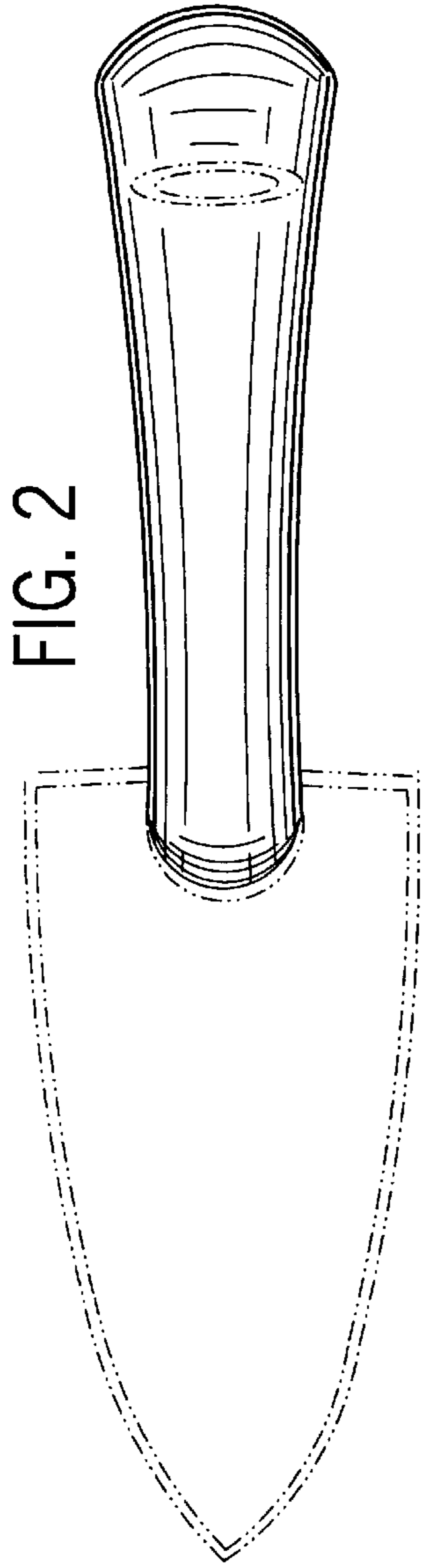
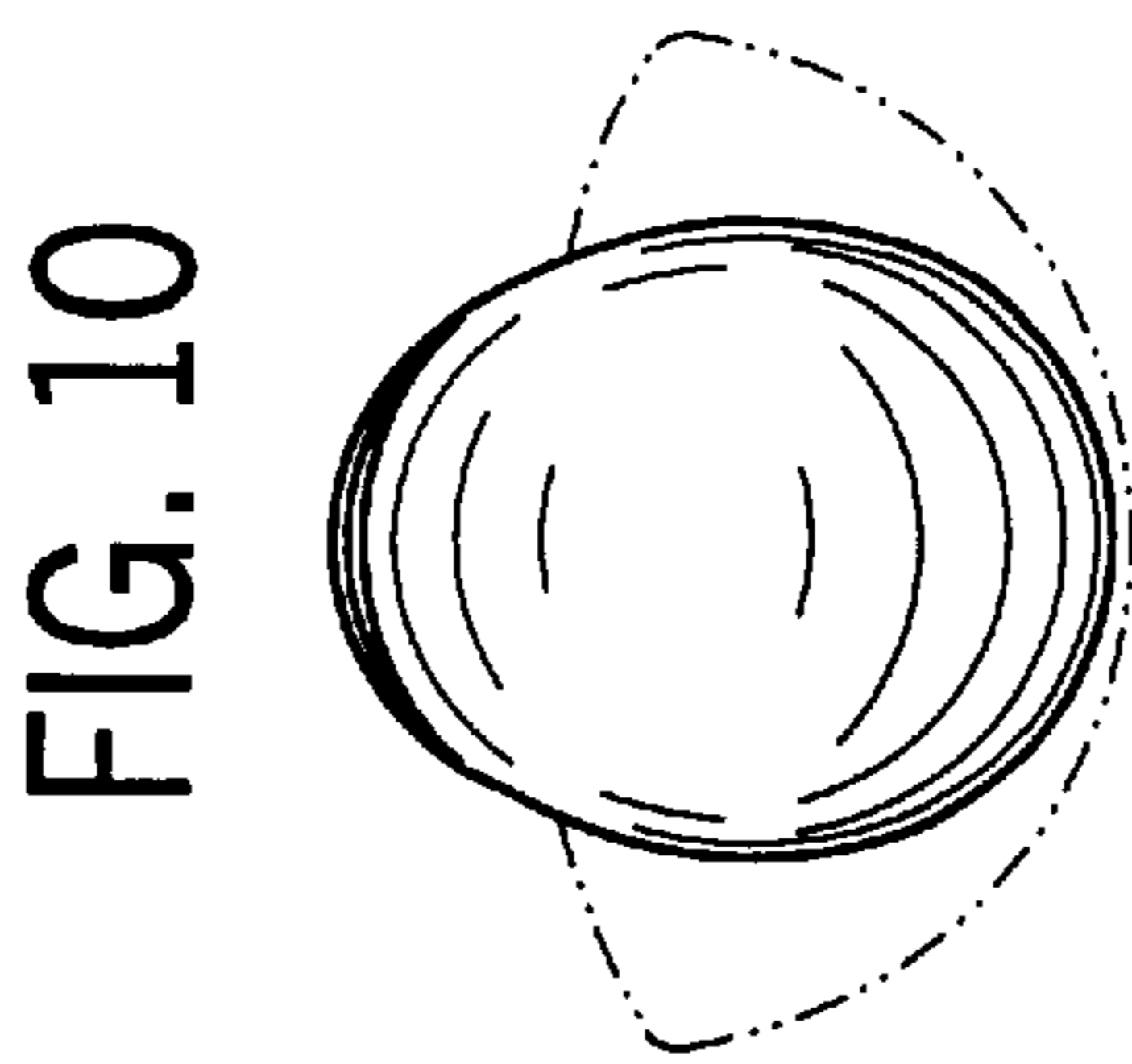
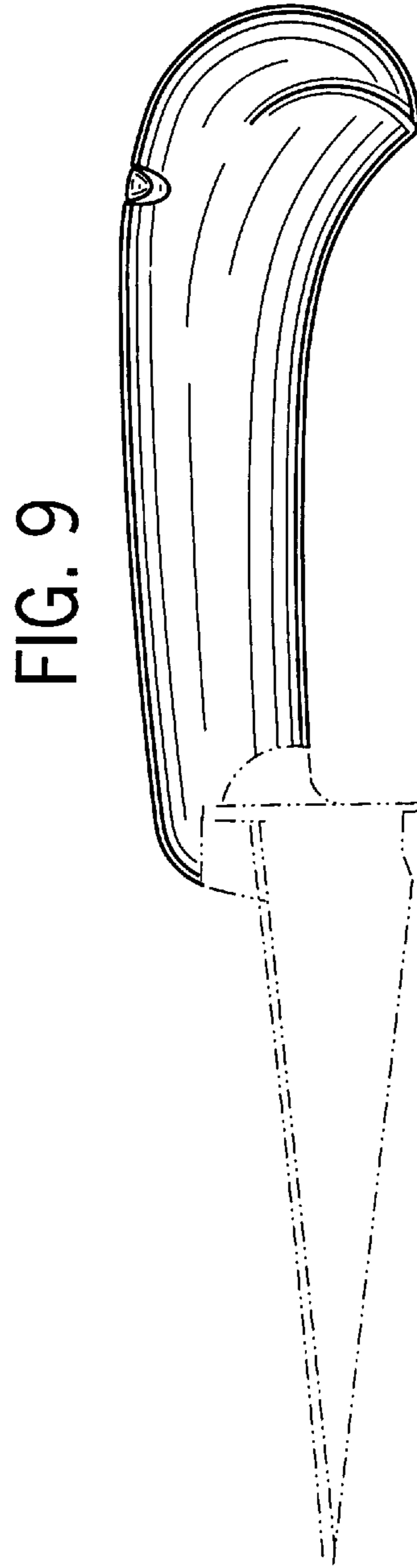
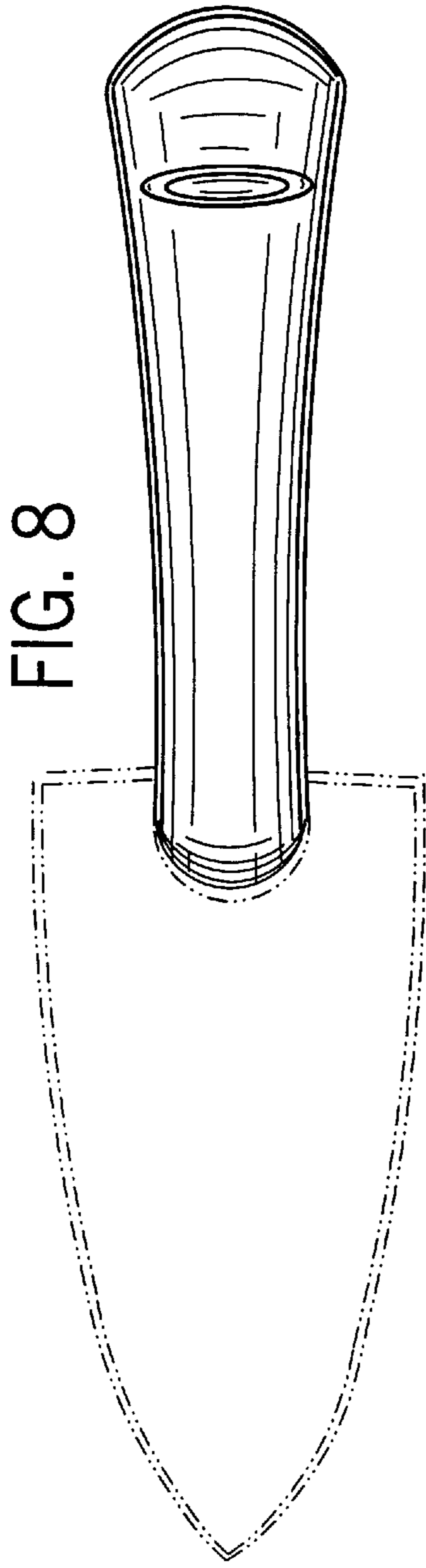

FIG. 7





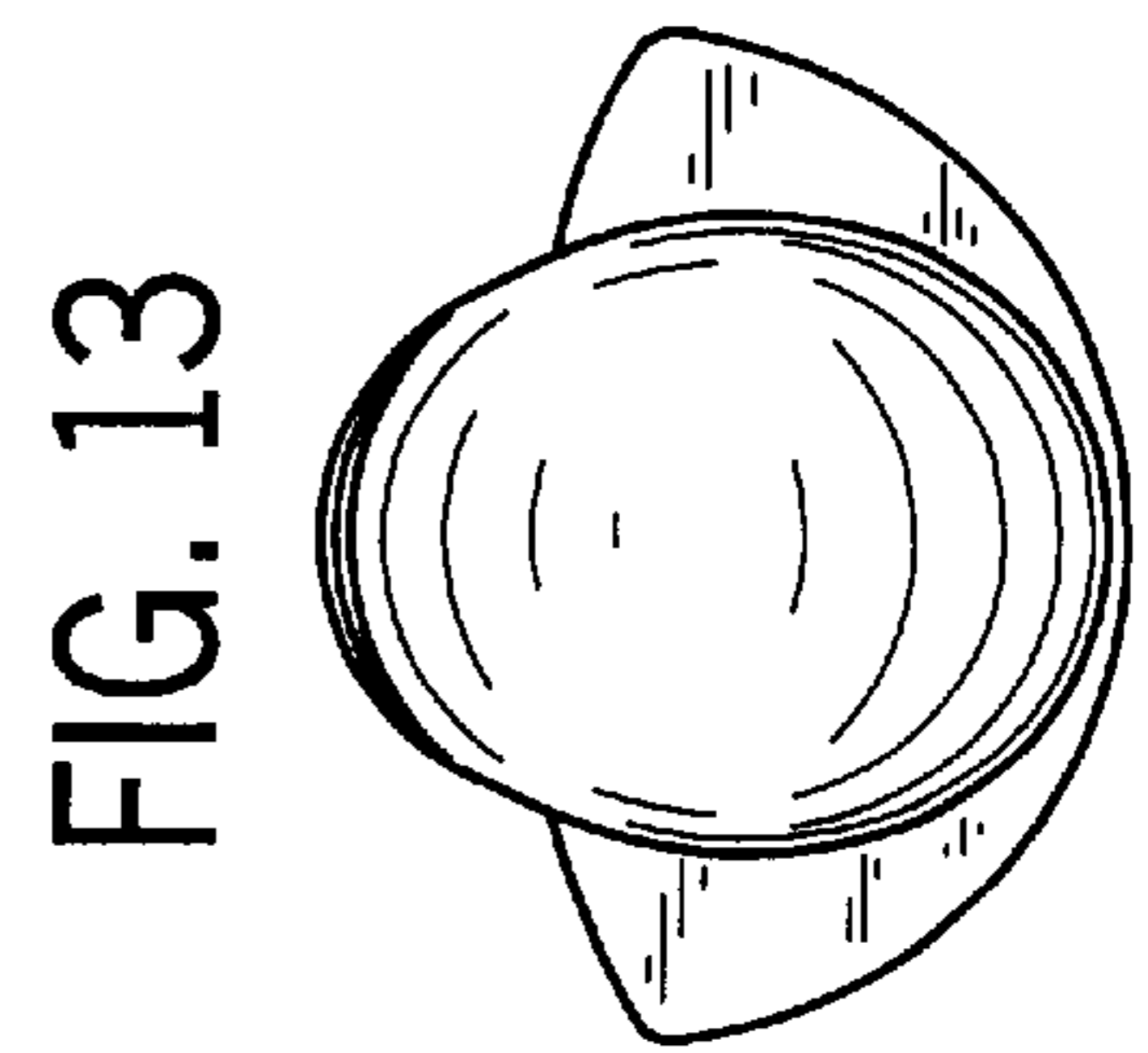
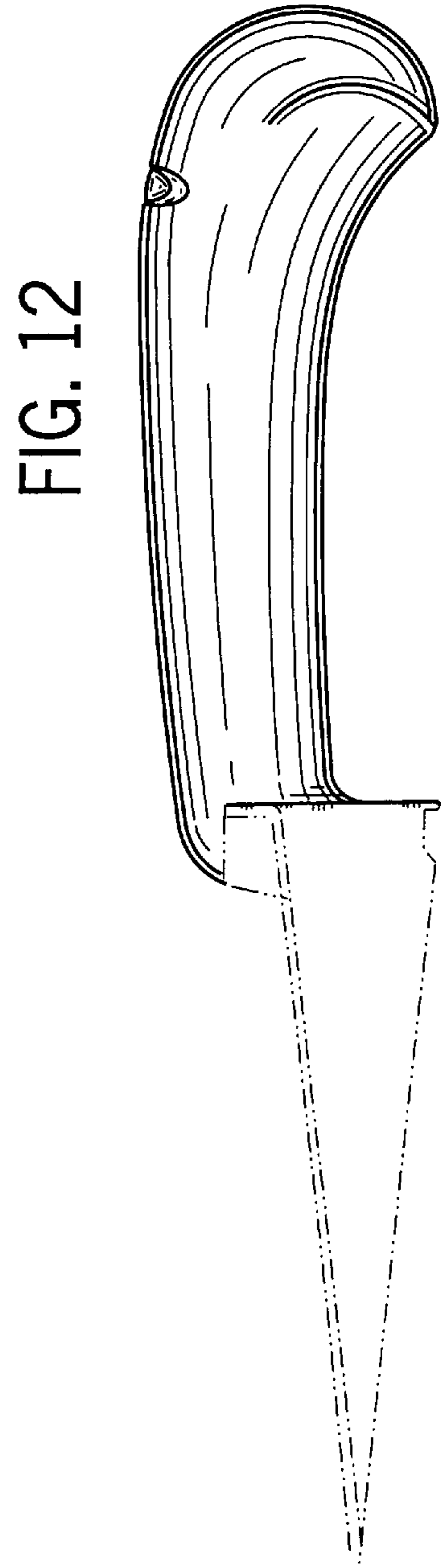
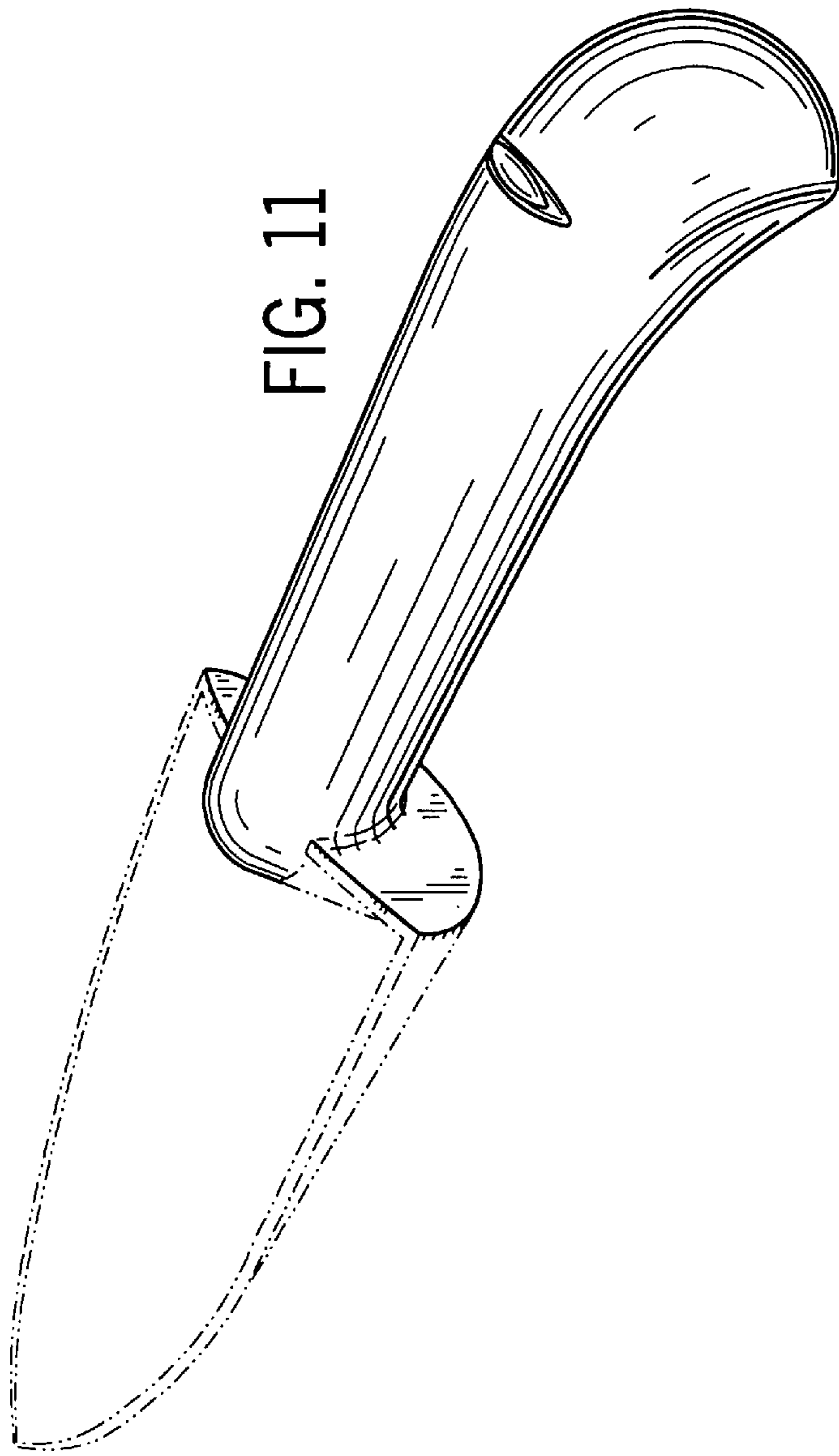

FIG. 14

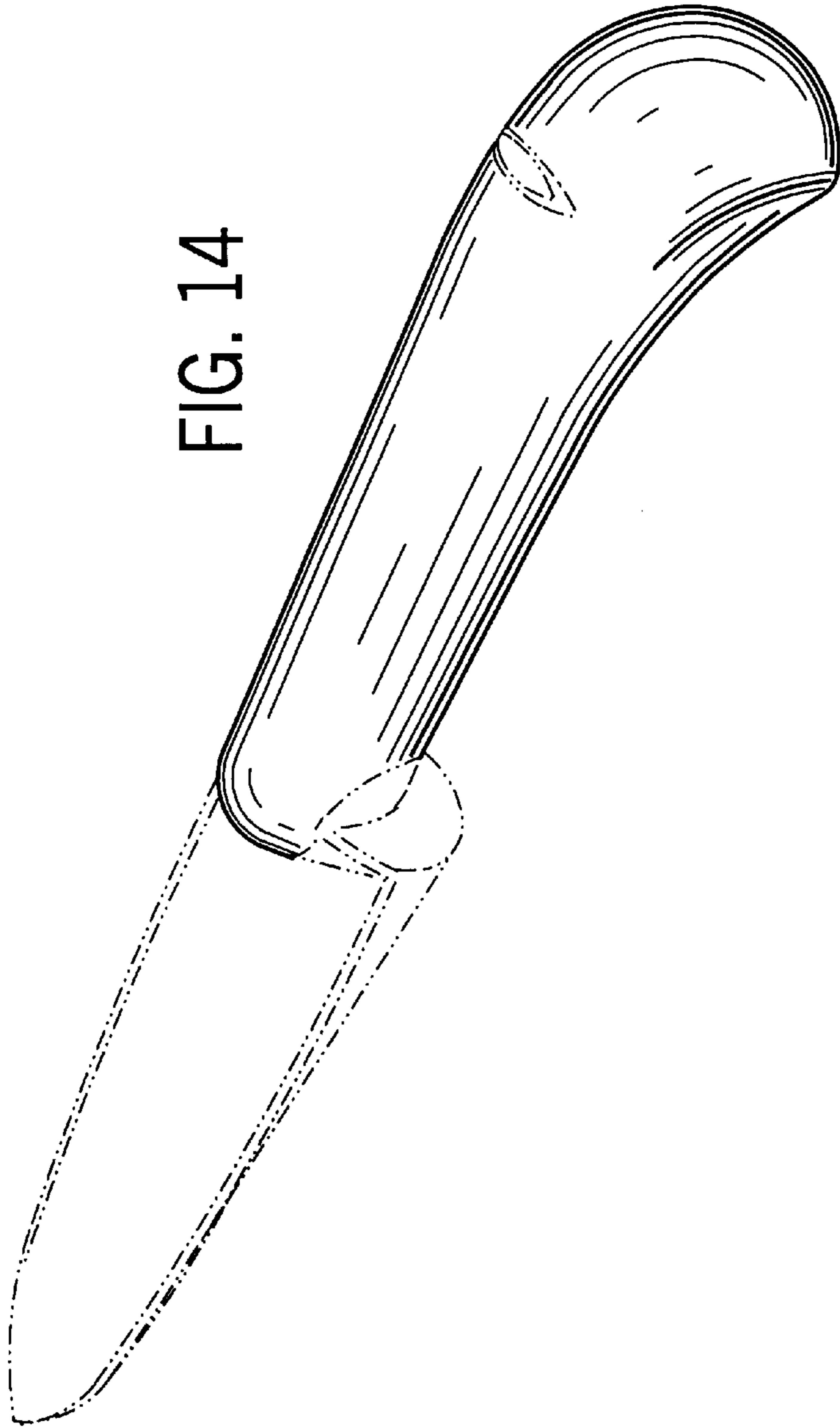

FIG. 15

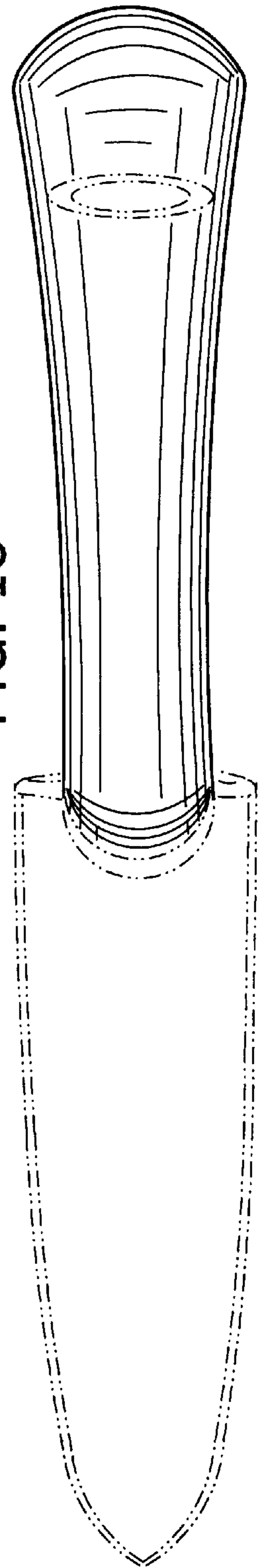

FIG. 16

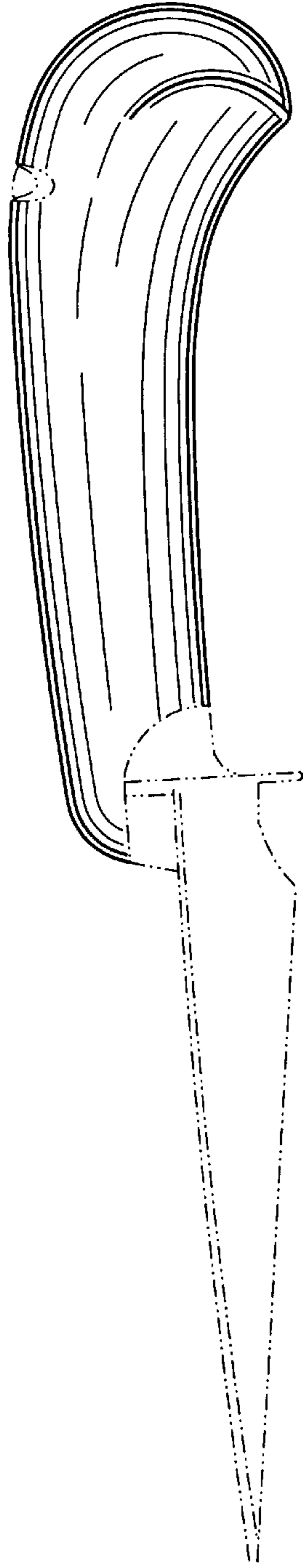

FIG. 17

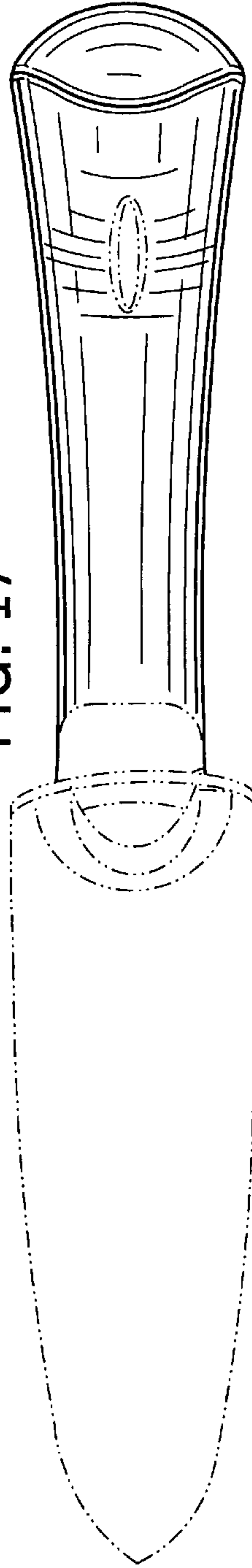

FIG. 18

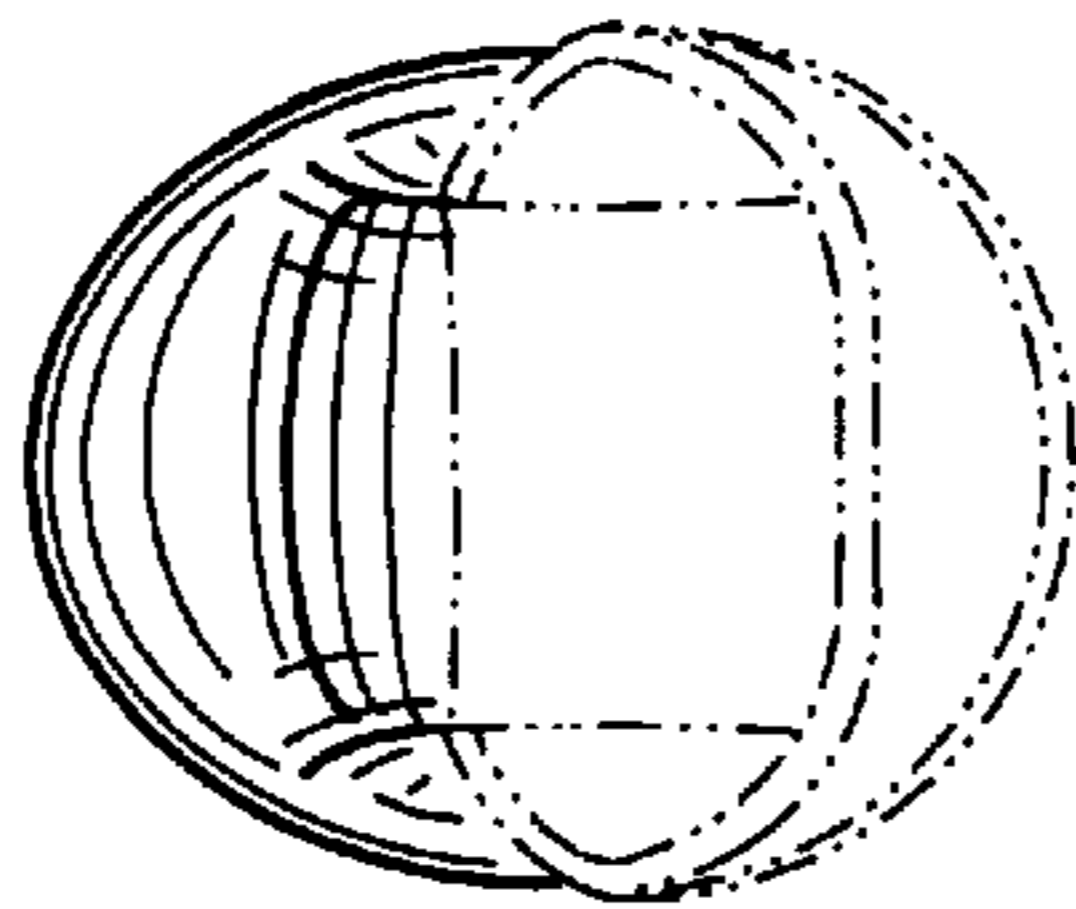
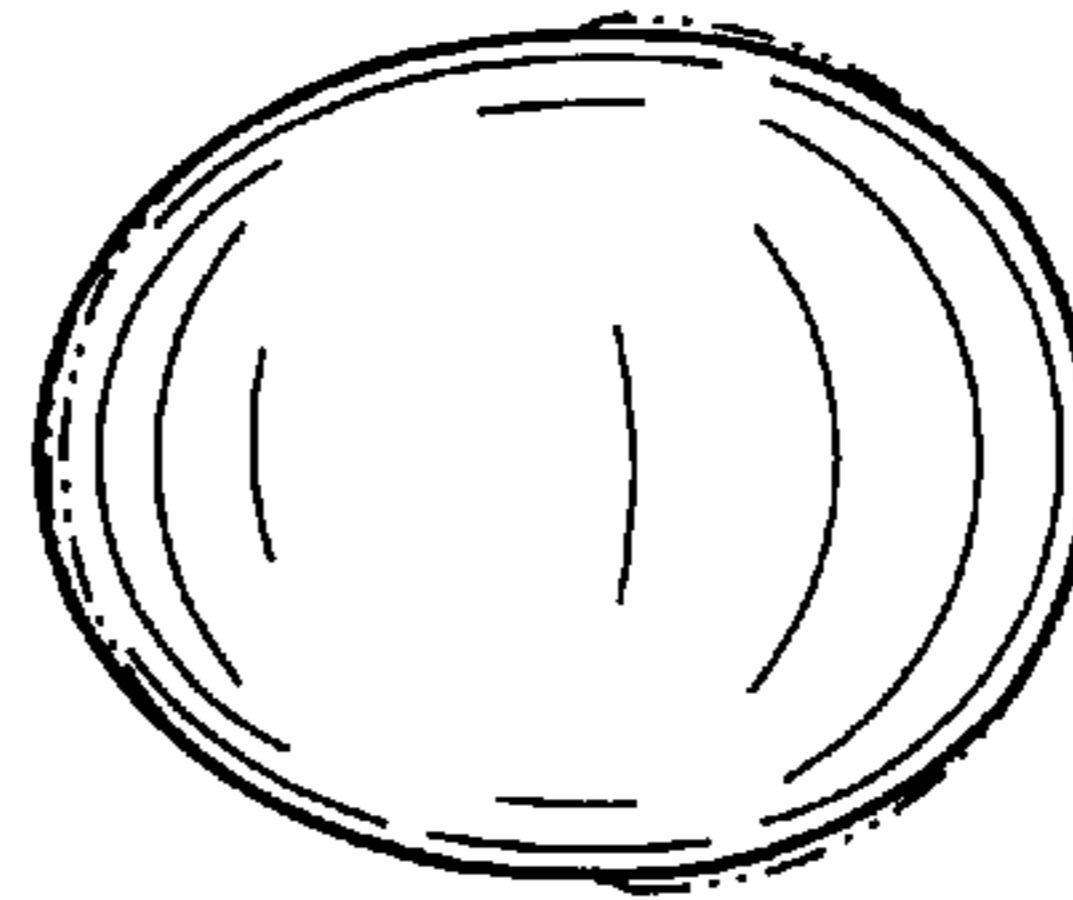

FIG. 19



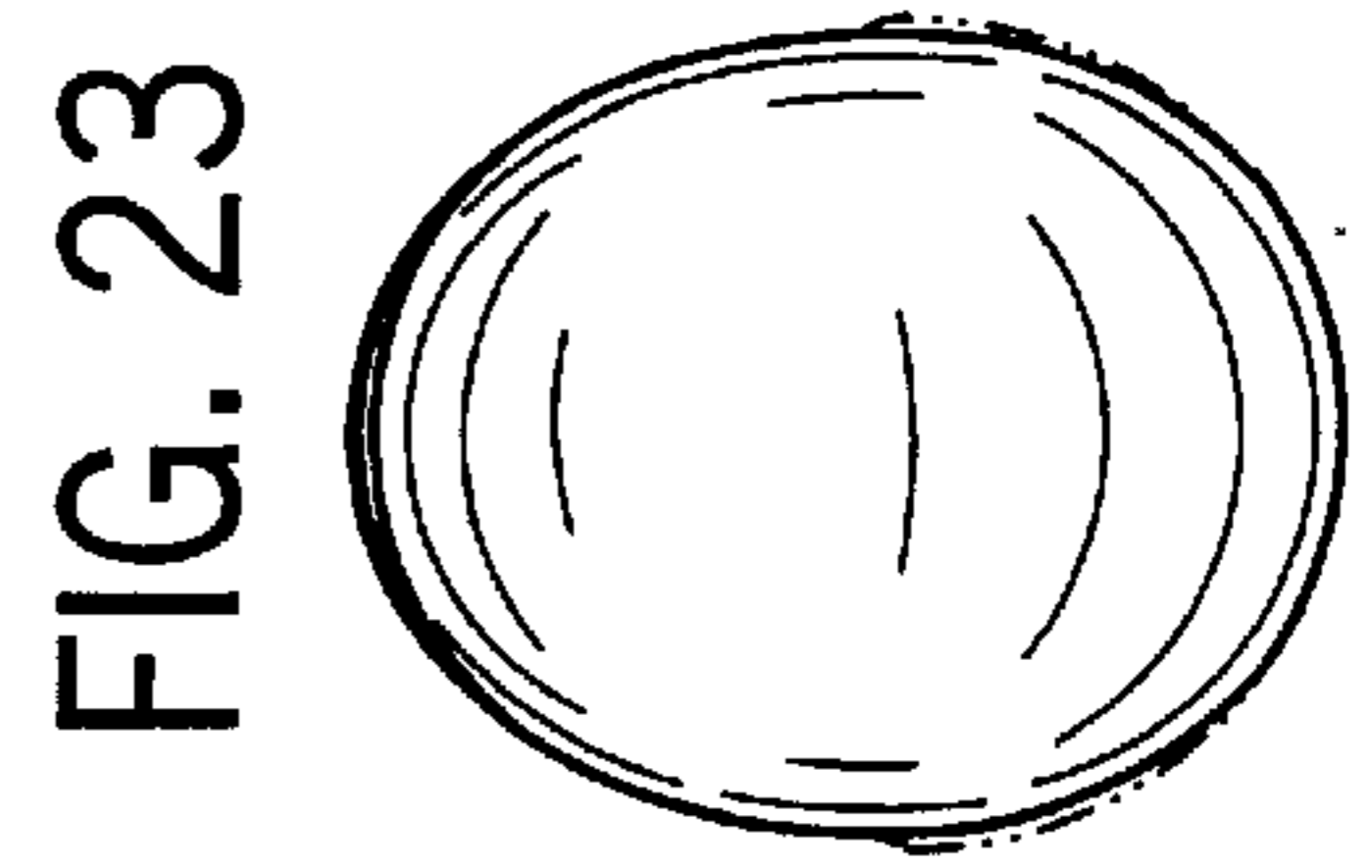
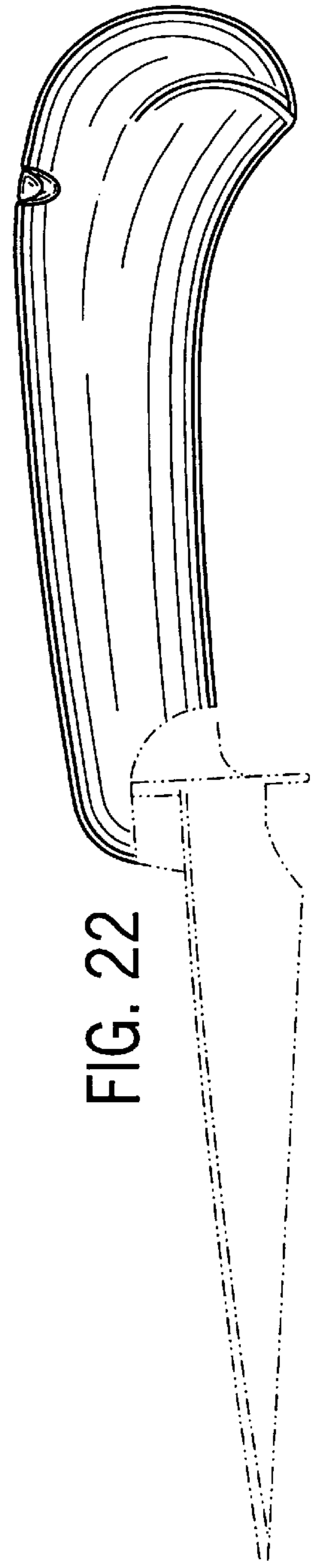
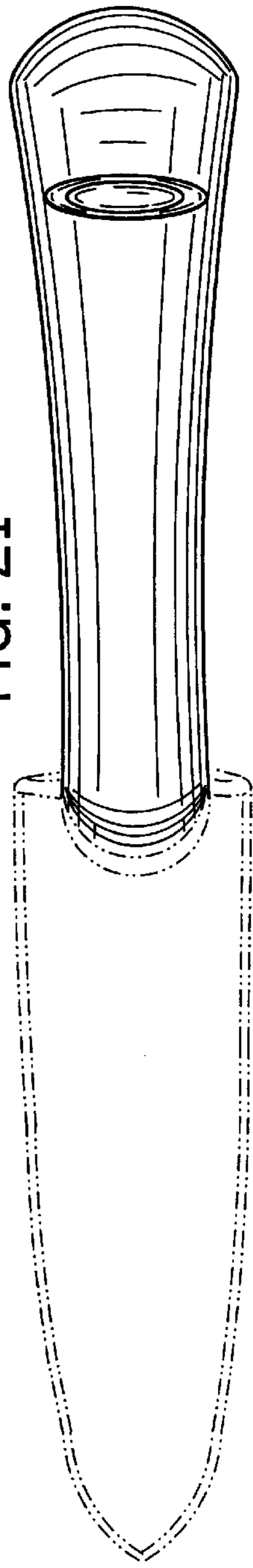
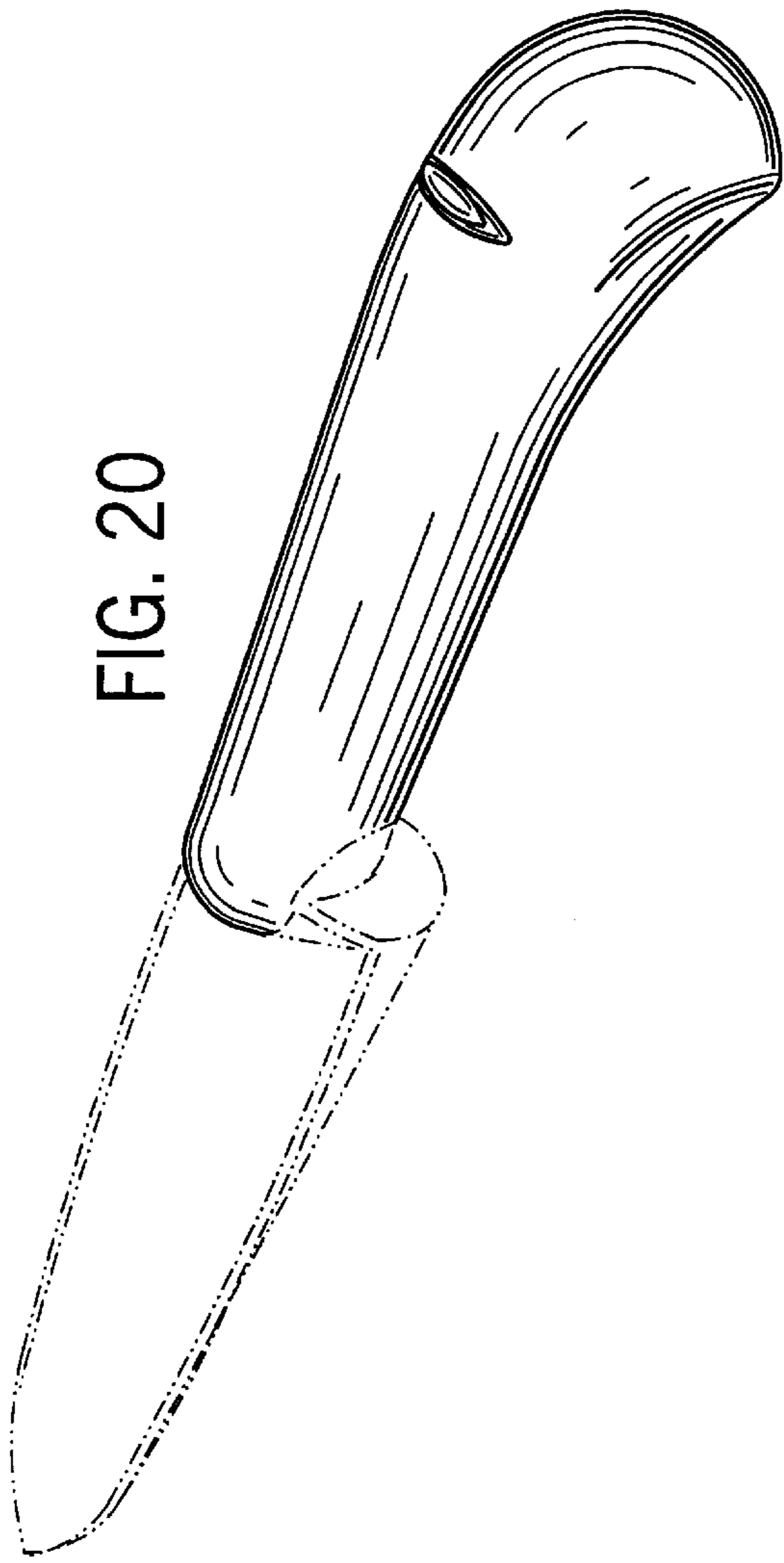

FIG. 24

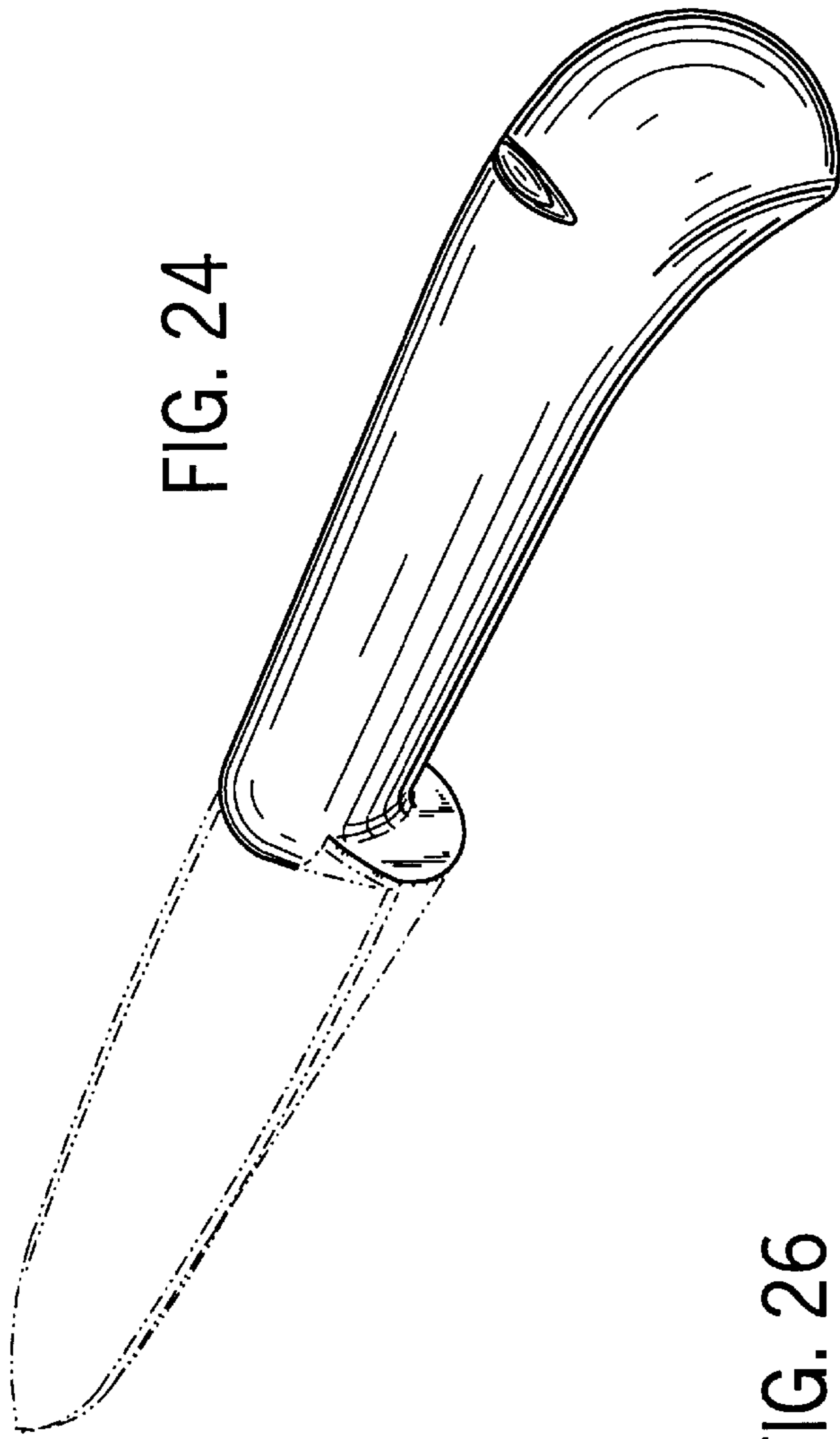

FIG. 26

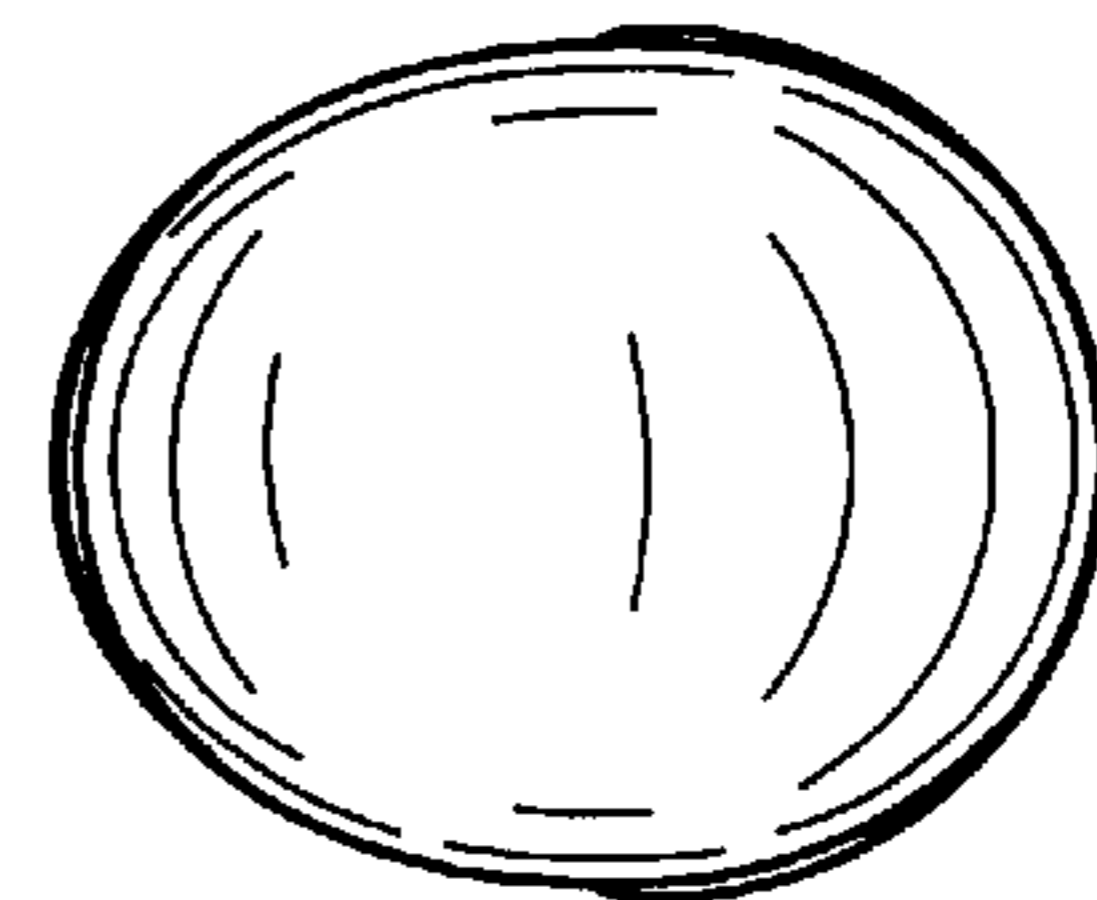

FIG. 25

