



US00D434467S

United States Patent [19]
Joll

[11] **Patent Number: Des. 434,467**

[45] **Date of Patent: ** Nov. 28, 2000**

[54] **RAILWAY CAR AIR BRAKE RESERVOIR**

[75] Inventor: **Ronald P. Joll**, Fonthill, Canada

[73] Assignee: **Vineland Manufacturing Ltd.**,
Vineland Station, Canada

[**] Term: **14 Years**

[21] Appl. No.: **29/101,790**

[22] Filed: **Mar. 10, 1999**

[51] **LOC (7) Cl.** **23-01**

[52] **U.S. Cl.** **D23/202; D23/205; D12/42**

[58] **Field of Search** **D23/202, 205;**
220/587; 303/85; 137/576

[56] **References Cited**

U.S. PATENT DOCUMENTS

1,891,644	12/1932	Hewitt	303/85
4,564,246	1/1986	Billeter	303/85
5,307,836	5/1994	Niceley	137/576
5,937,960	8/1999	Dewey	180/68.3

Primary Examiner—Robin V. Taylor

Attorney, Agent, or Firm—Gowling Lafleur Henderson LLP

[57] **CLAIM**

The ornamental design for a railway car air brake reservoir, as shown and described.

DESCRIPTION

FIG. 1 is a perspective view of a railway car air brake reservoir according to the present invention, showing the side and front end thereof;

FIG. 2 is a perspective view of the railway car air brake reservoir, showing the side and rear end thereof;

FIG. 3 is a perspective view of the railway car air brake reservoir, showing the bottom thereof;

FIG. 4 is a perspective view of the railway car air brake reservoir, showing the top thereof;

FIG. 5 is a perspective view of one variation of the railway car air brake reservoir shown in FIGS. 1 to 4;

FIG. 6 is a perspective view of the railway car air brake reservoir variation depicted in FIG. 5, showing the side and rear end thereof; and,

FIG. 7 is a perspective view of the railway car air brake reservoir variation depicted in FIG. 5, showing the bottom thereof.

1 Claim, 7 Drawing Sheets

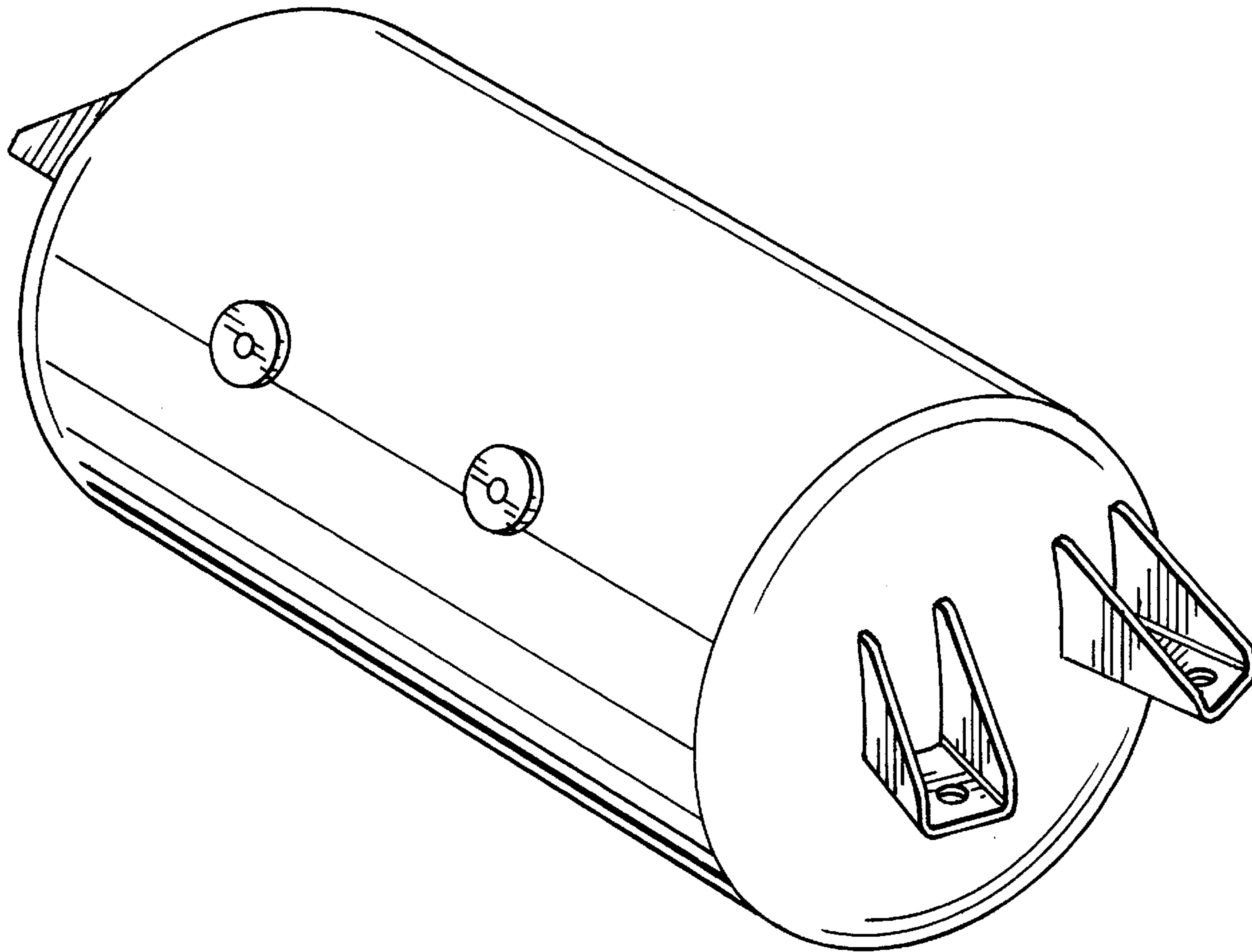

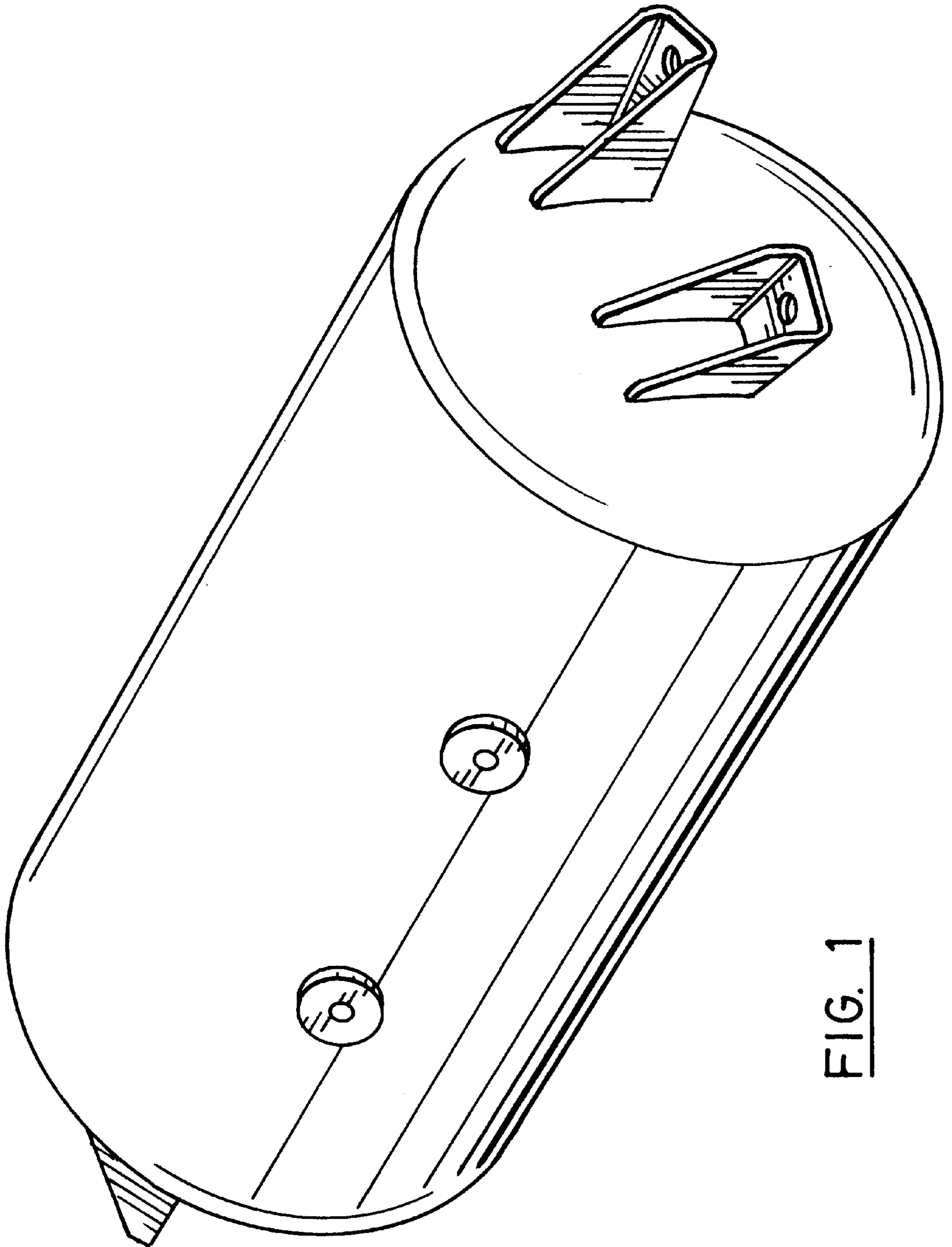

FIG. 1

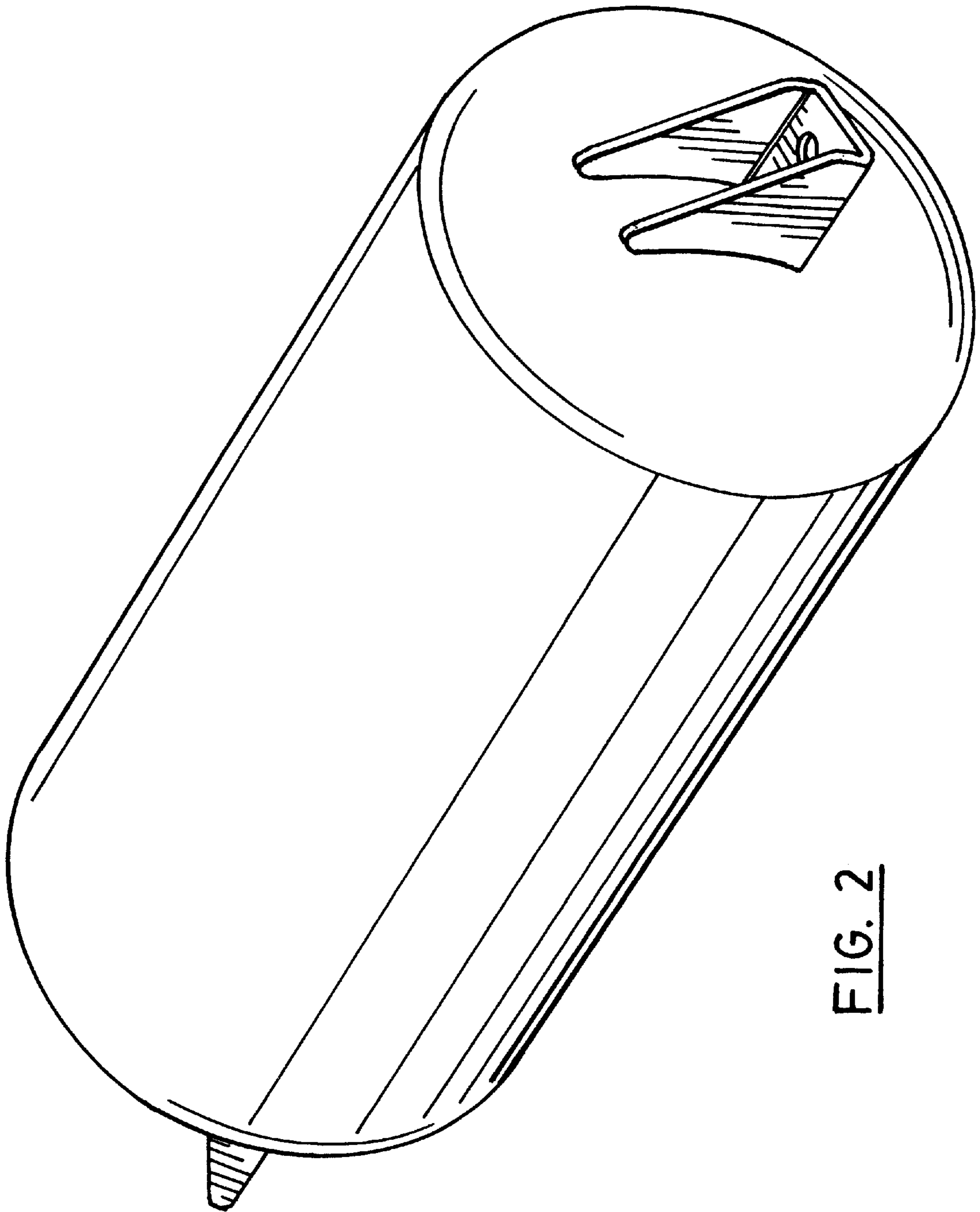

FIG. 2

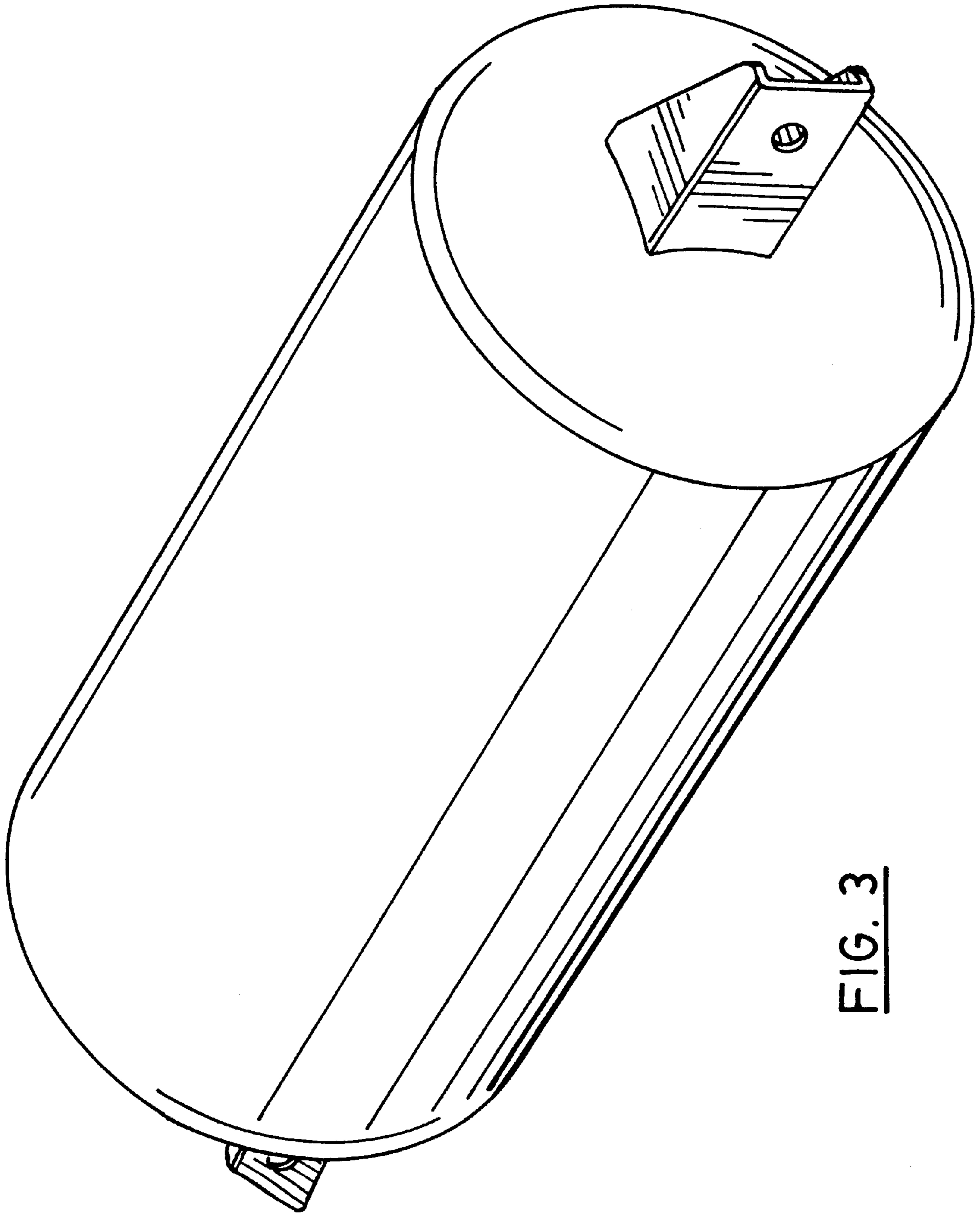

FIG. 3

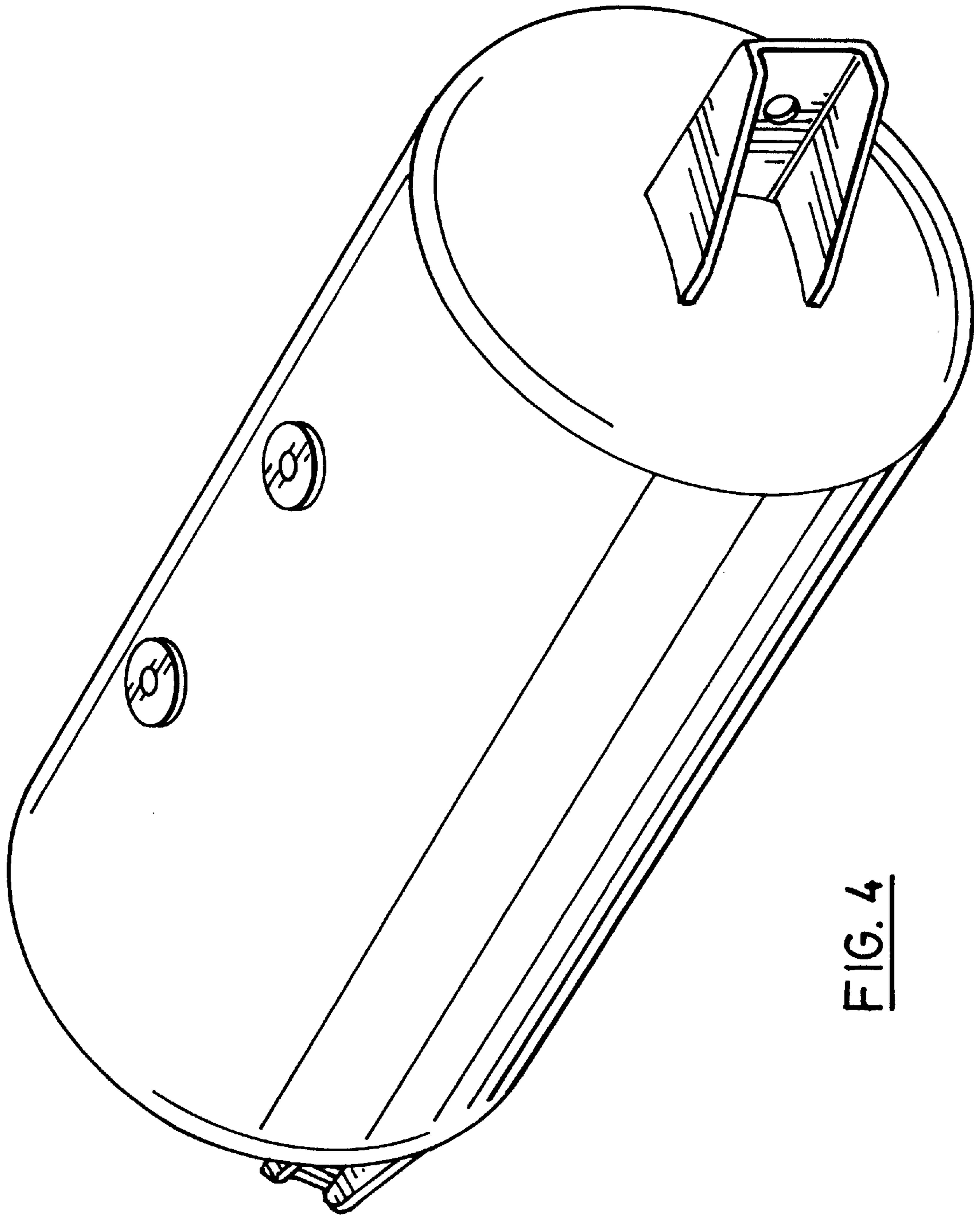

FIG. 4

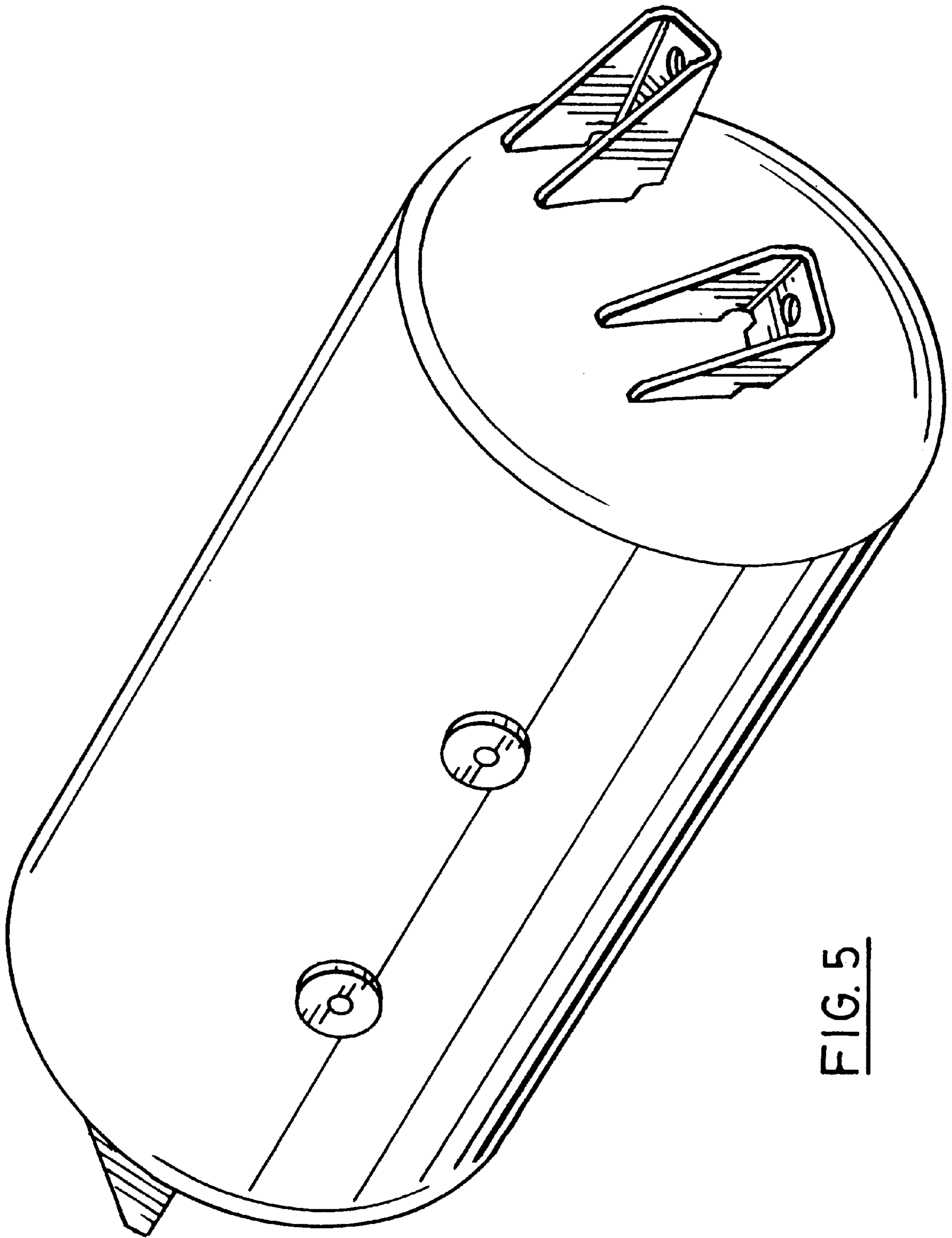

FIG. 5

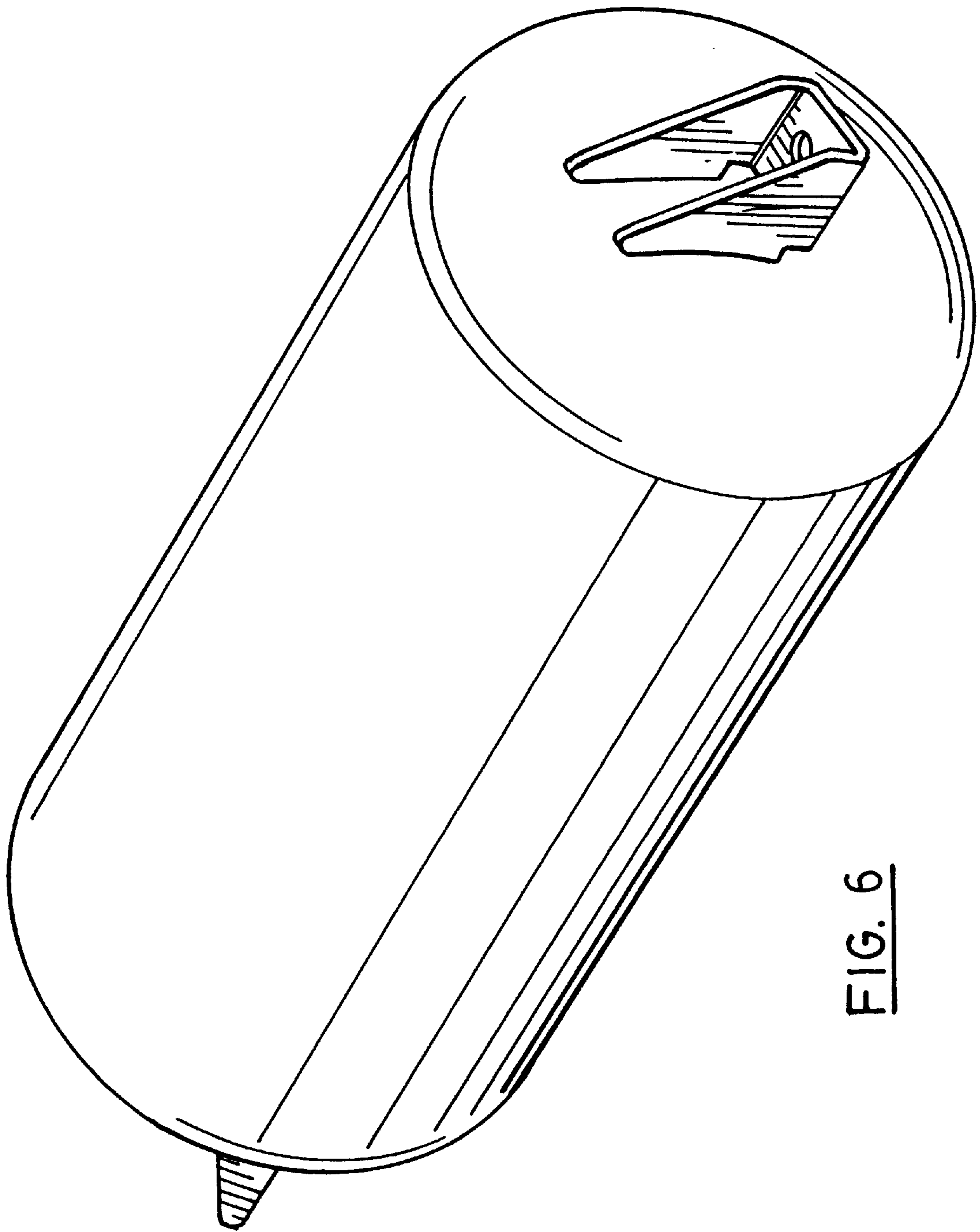

FIG. 6

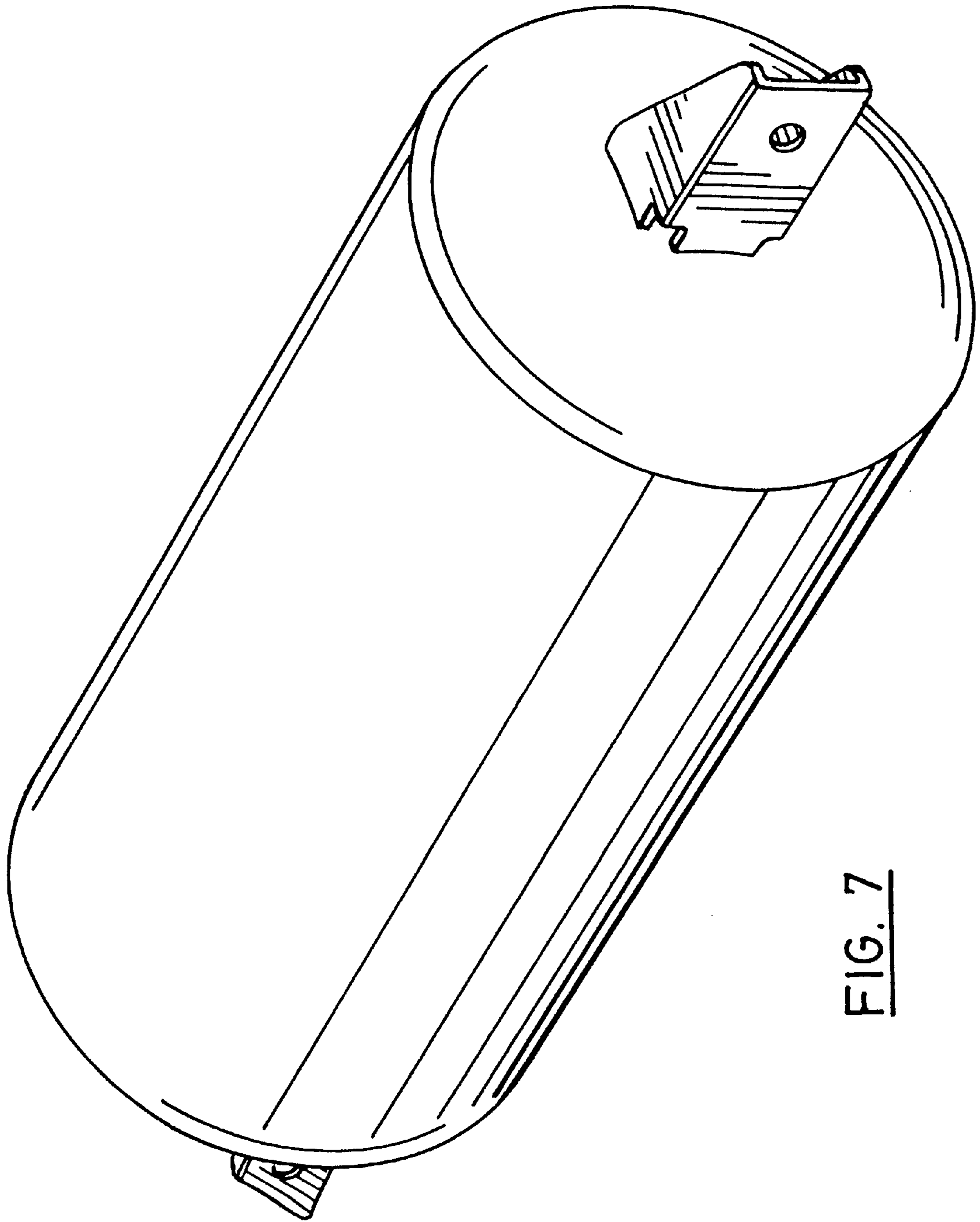

FIG. 7