



US00D434370S

# United States Patent [19]

[11] **Patent Number: Des. 434,370**

Sun et al.

[45] **Date of Patent: \*\* Nov. 28, 2000**

## [54] TRAVEL CHARGER

[75] Inventors: **Yeo Chung Sun; Jeremy Sun Ting Kung; Jeanna Kimbré**, all of Singapore, Singapore

[73] Assignee: **Telefonaktiebolaget LM Ericsson**, Stockholm, Sweden

[\*\*] Term: **14 Years**

[21] Appl. No.: **29/103,077**

[22] Filed: **Apr. 8, 1999**

### [30] Foreign Application Priority Data

Oct. 8, 1998	[SE]	Sweden	.....	98-1977
Oct. 8, 1998	[SE]	Sweden	.....	98-1978
Oct. 8, 1998	[SE]	Sweden	.....	98-1979
Oct. 8, 1998	[SE]	Sweden	.....	98-1980

[51] **LOC (7) Cl.** ..... **13-02**

[52] **U.S. Cl.** ..... **D13/107**

[58] **Field of Search** ..... D13/107, 108; 363/146; 320/110-115

## [56] References Cited

### U.S. PATENT DOCUMENTS

D. 347,617	6/1994	Tattari	.....	D13/107
D. 394,641	5/1998	Seragnoli	.....	D13/108
D. 406,259	3/1999	Lindahl	.....	D13/110
4,543,624	9/1985	Rumble	.....	363/146
5,613,863	3/1997	Klaus et al.	.....	439/131
5,744,934	4/1998	Wu	.....	320/111
5,973,948	10/1999	Hahn et al.	.....	363/146

*Primary Examiner*—Joel Sincavage

*Attorney, Agent, or Firm*—Burns, Doane, Swecker & Mathis, L.L.P.

## [57] CLAIM

The ornamental design for a travel charger, as shown and described.

### DESCRIPTION

FIG. 1 is a front, left perspective view of a travel charger showing our new design;

FIG. 2 is a bottom plan view thereof;

FIG. 3 is a front end elevational view thereof;

FIG. 4 is a rear end elevational view thereof;

FIG. 5 is a left side elevational view thereof;

FIG. 6 is a top plan view thereof;

FIG. 7 is a right side elevational view thereof;

FIG. 8 is a front, left perspective view of a travel charger showing our new design in a second environment;

FIG. 9 is a bottom plan view thereof;

FIG. 10 is a front end elevational view thereof;

FIG. 11 is a rear end elevational view thereof;

FIG. 12 is a left side elevational view thereof;

FIG. 13 is a top plan view thereof;

FIG. 14 is a right side elevational view thereof;

FIG. 15 is a front, left perspective view of a travel charger showing our new design in a third environment;

FIG. 16 is a bottom plan view thereof;

FIG. 17 is a front end elevational view thereof;

FIG. 18 is a rear end elevational view thereof;

FIG. 19 is a left side elevational view thereof;

FIG. 20 is a top plan view thereof;

FIG. 21 is a right side elevational view thereof;

FIG. 22 is a front, left perspective view of a travel charger showing our new design in a fourth environment;

FIG. 23 is a bottom plan view thereof;

FIG. 24 is a front end elevational view thereof;

FIG. 25 is a rear end elevational view thereof;

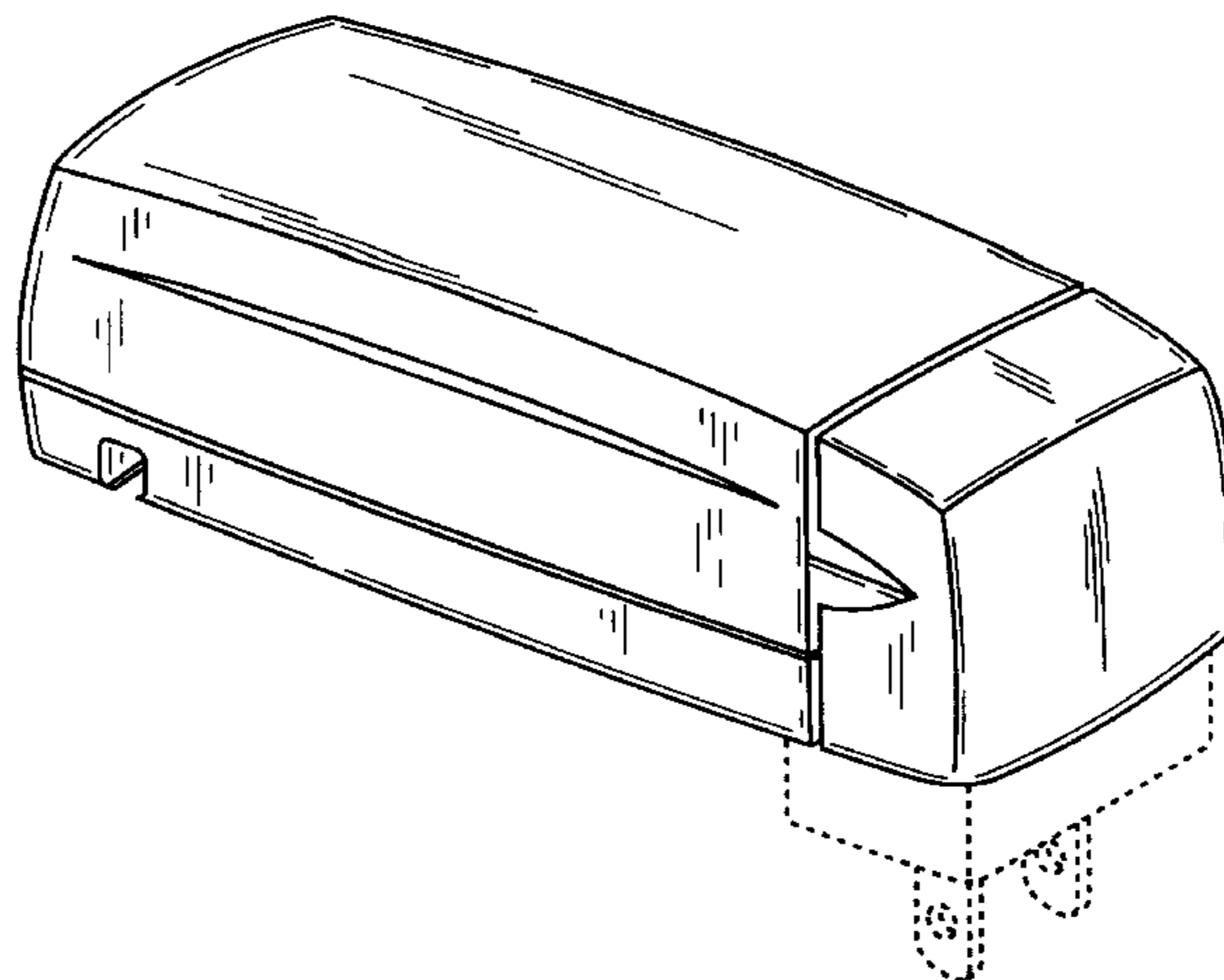
FIG. 26 is a left side elevational view thereof;

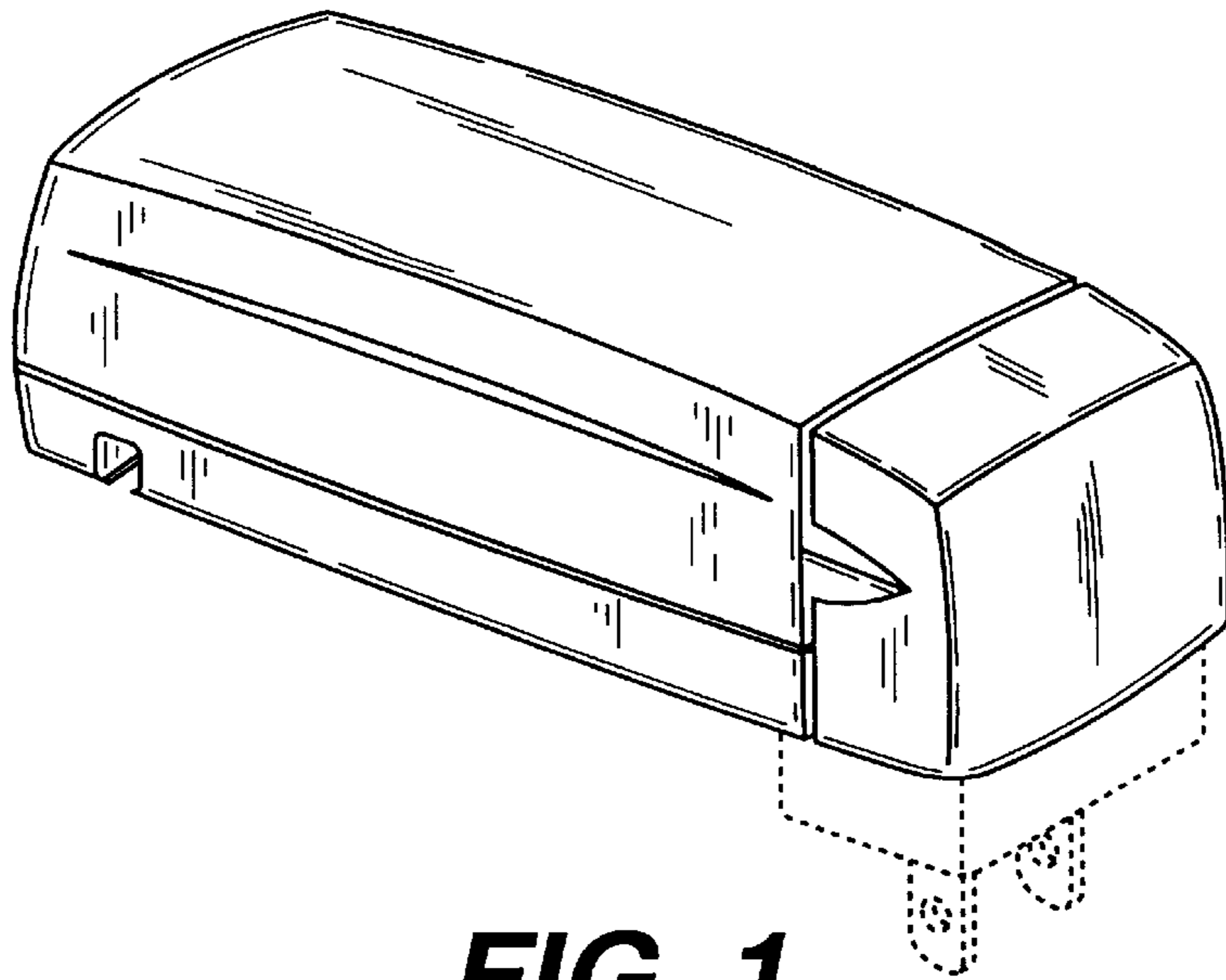
FIG. 27 is a top plan view thereof; and,

FIG. 28 is a right side elevational view thereof.

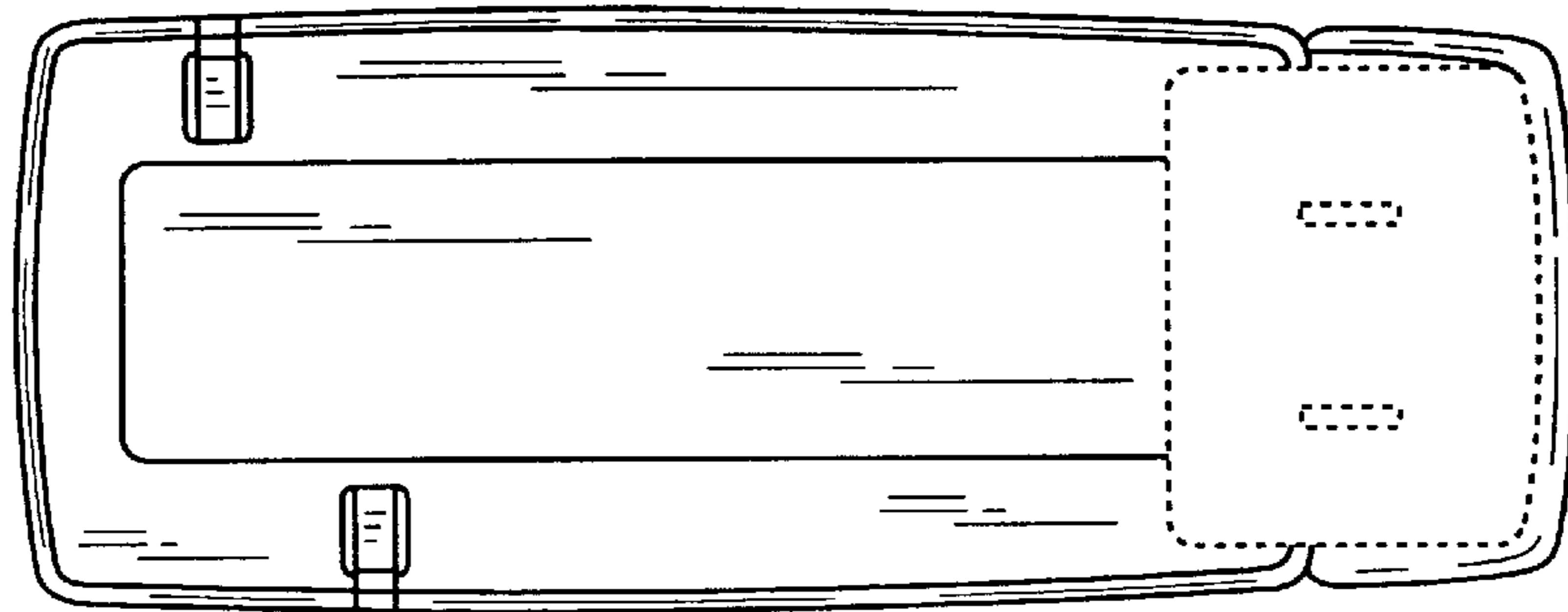
The broken line showing of the plug unit on the charger is for illustrative purposes only and forms no part of the claimed design.

**1 Claim, 8 Drawing Sheets**

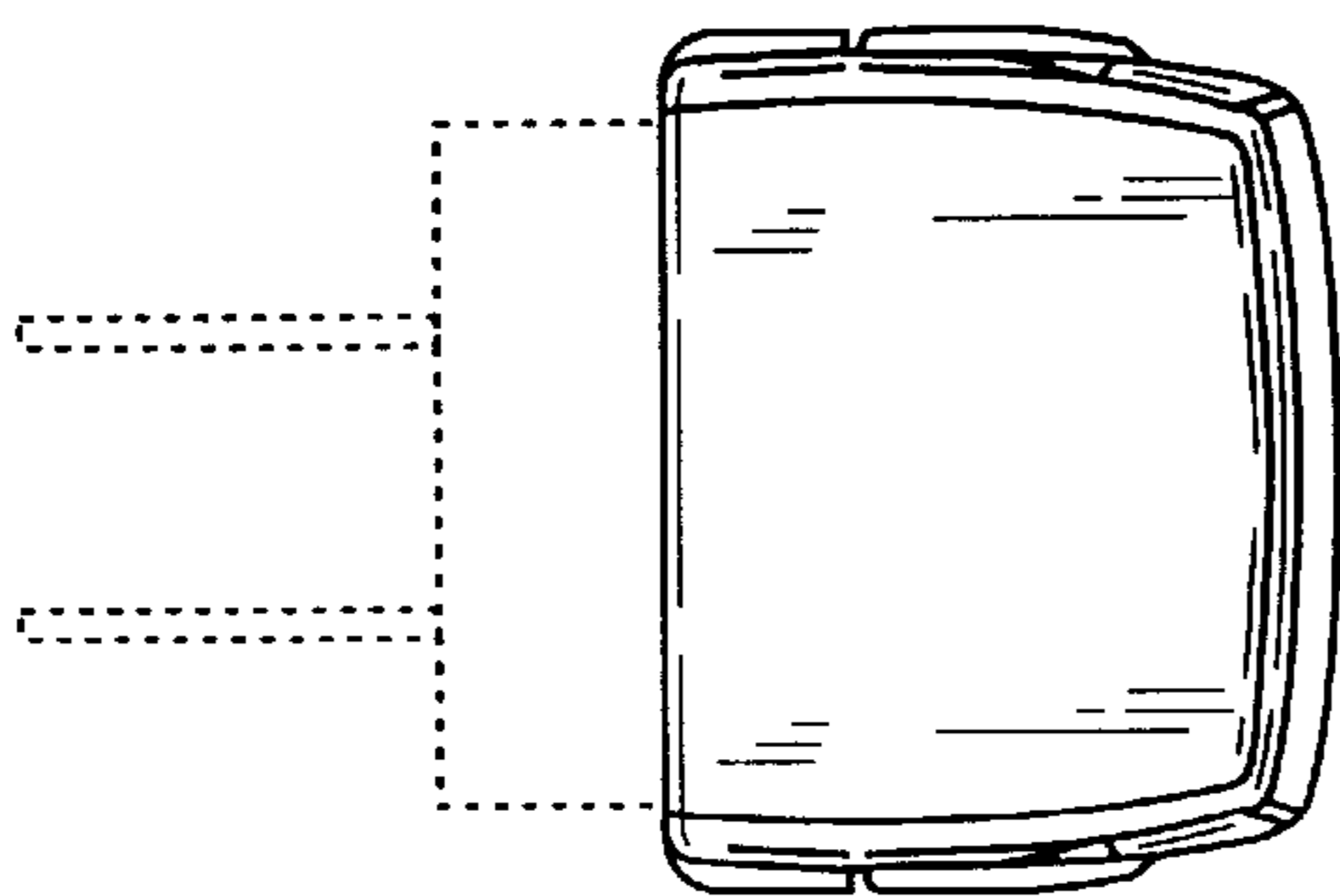




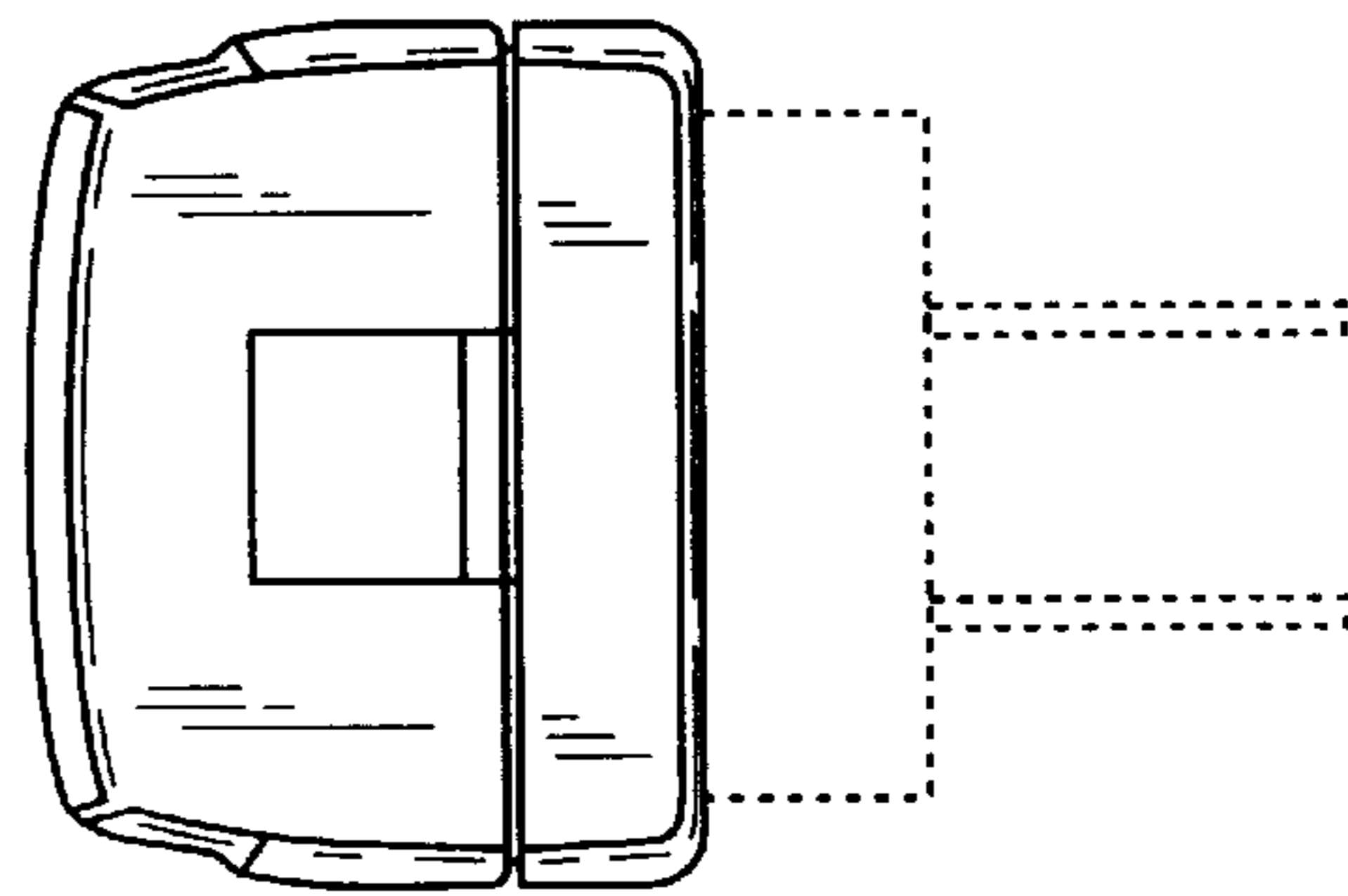
**FIG. 1**



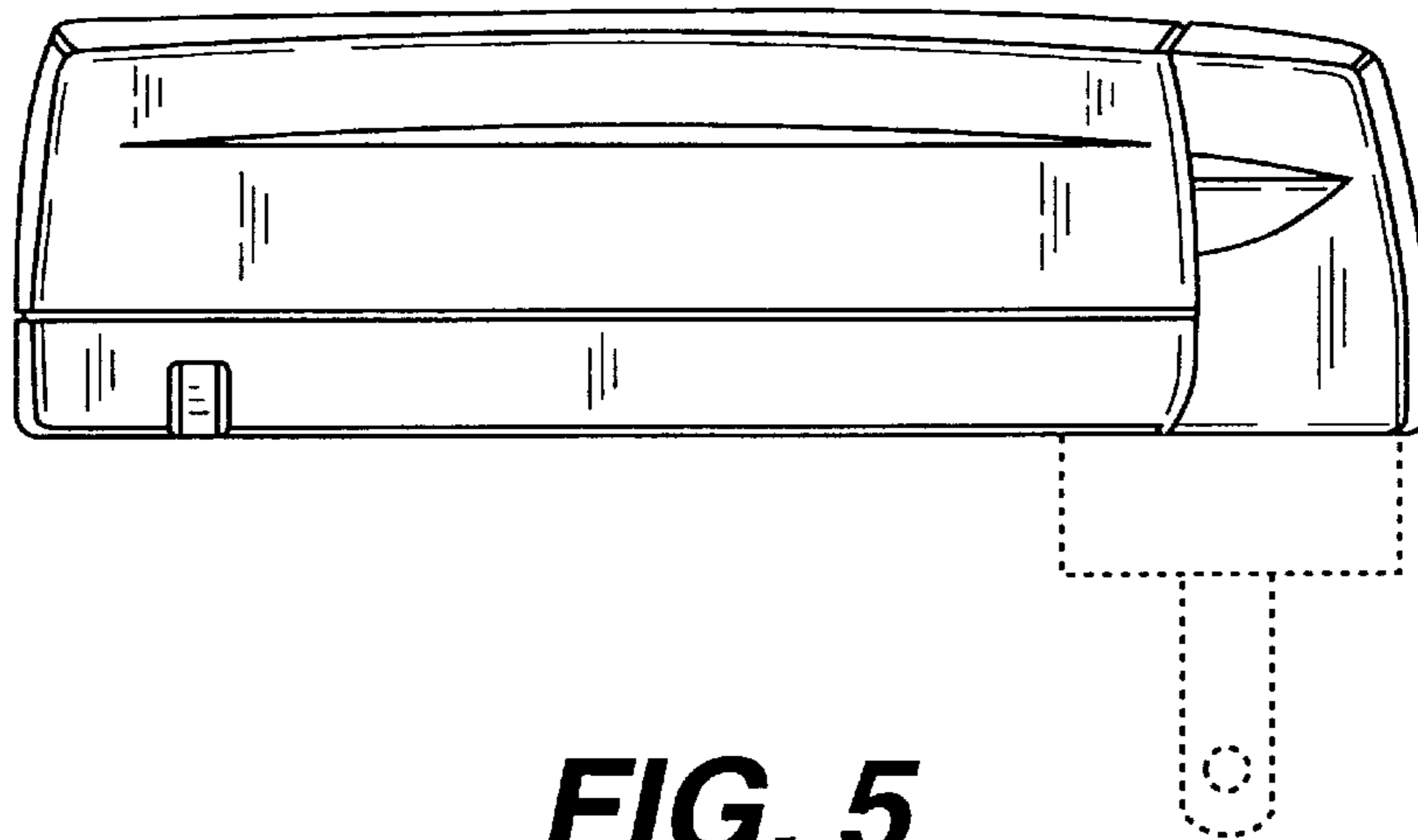
**FIG. 2**



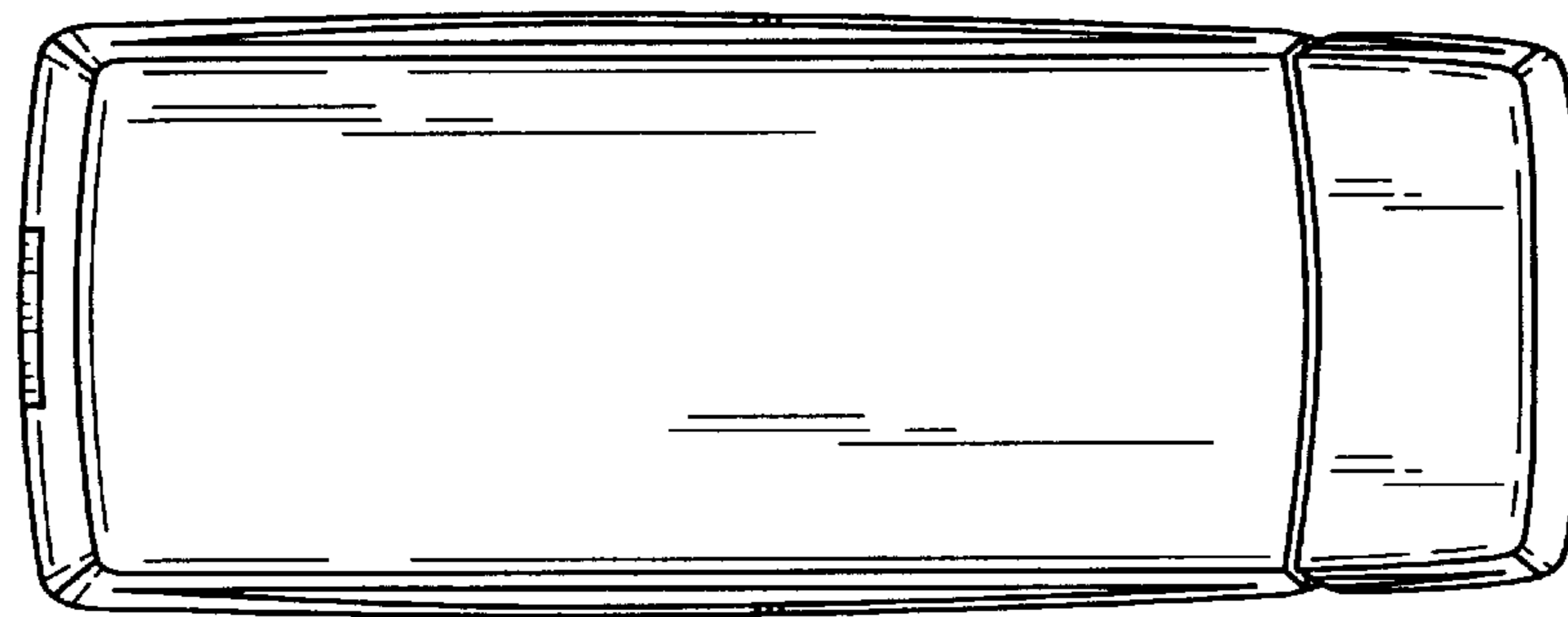
**FIG. 3**



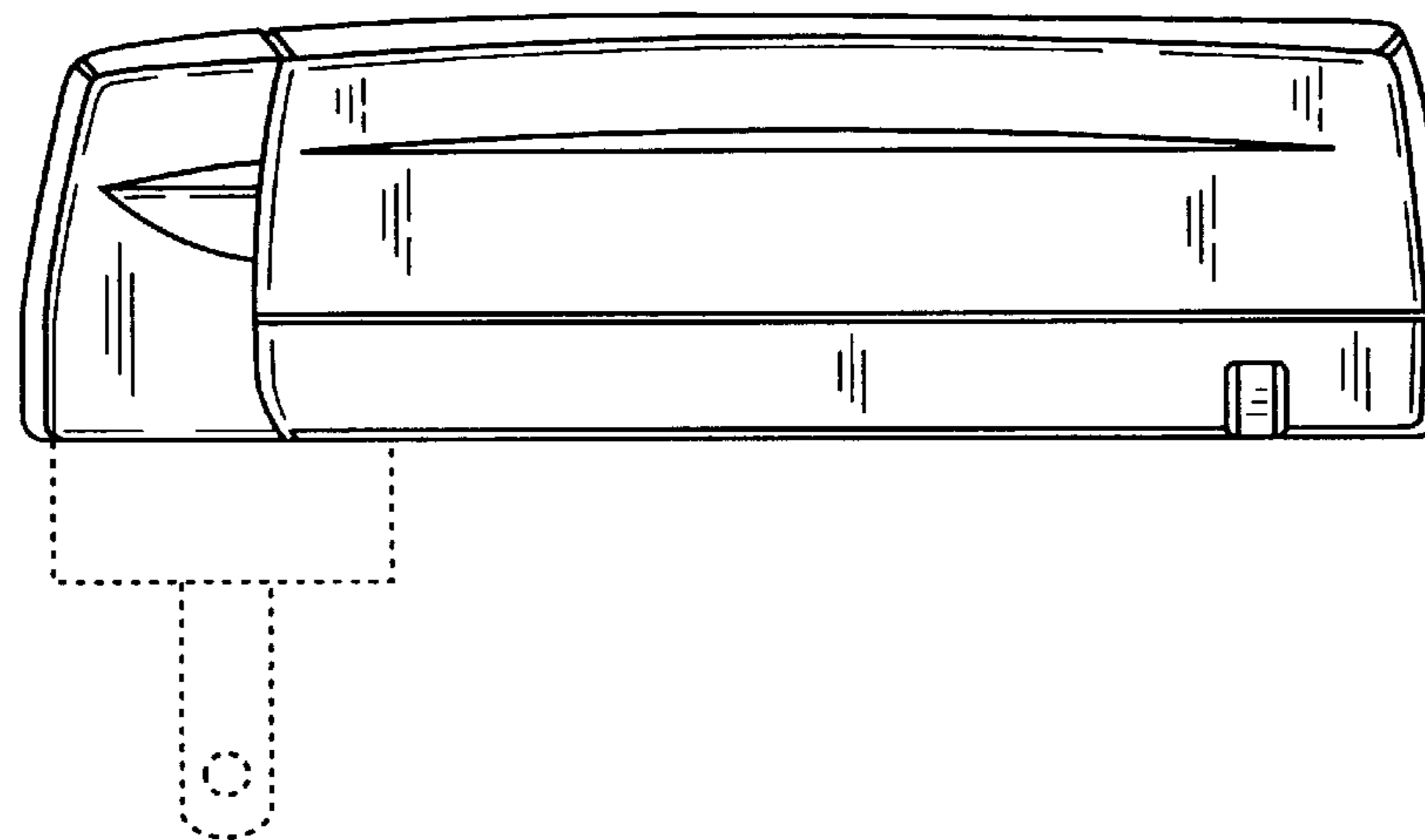
**FIG. 4**



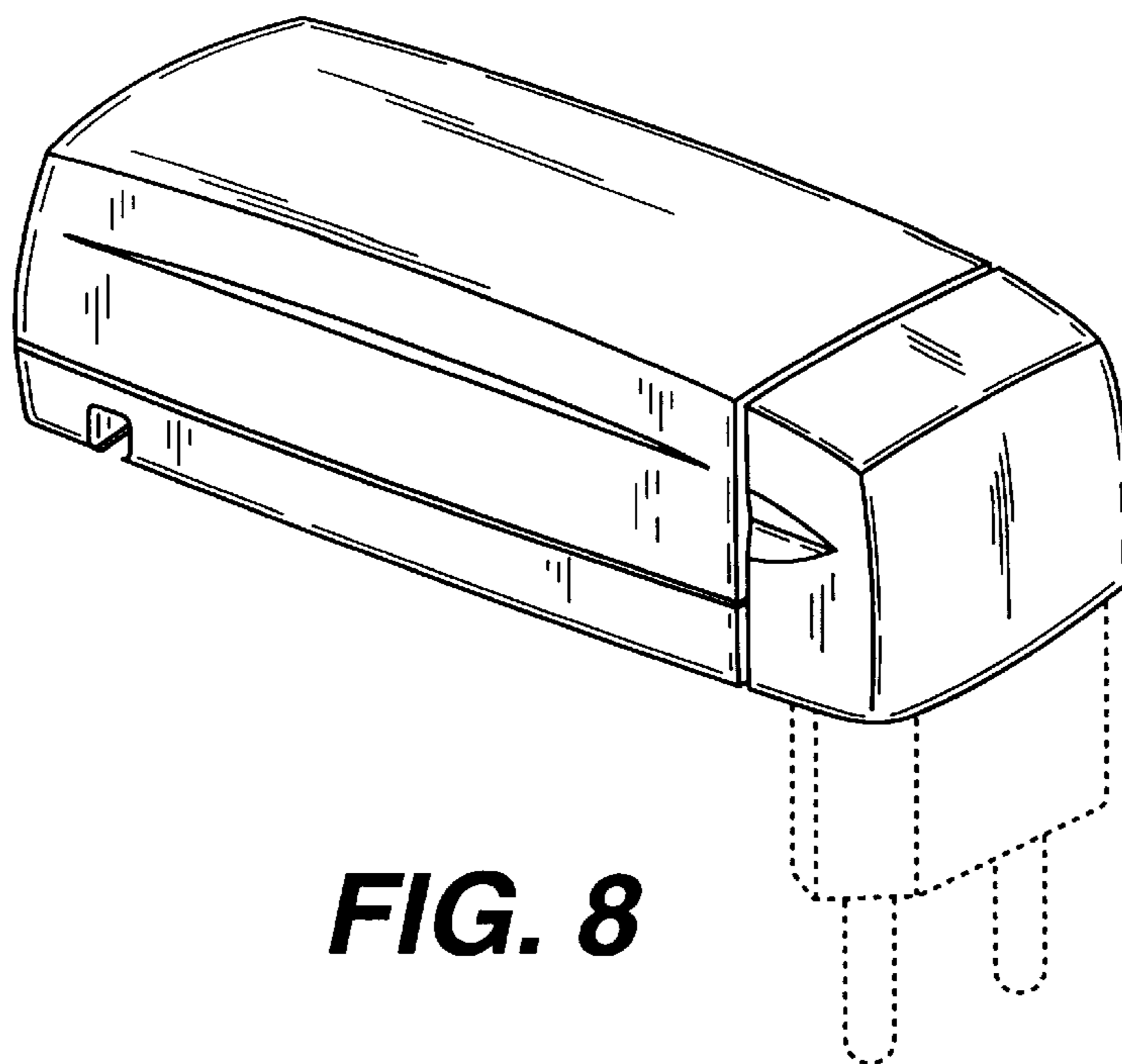
**FIG. 5**



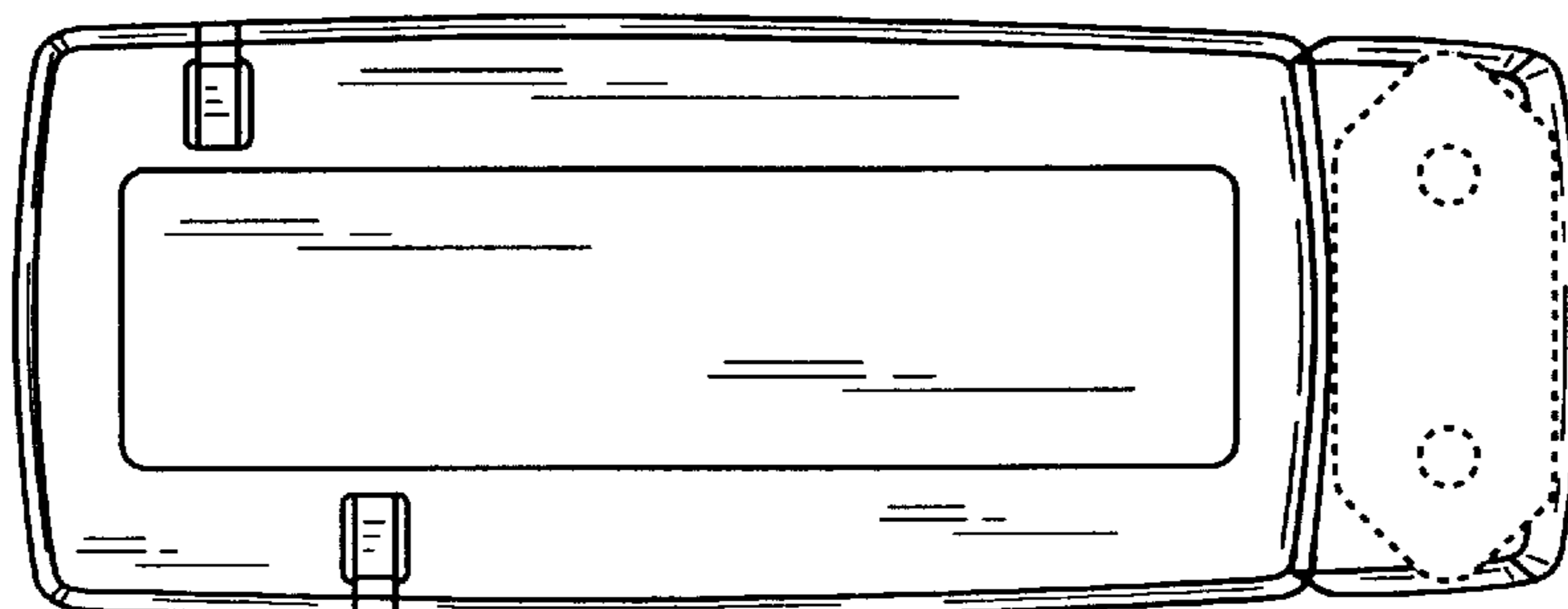
**FIG. 6**



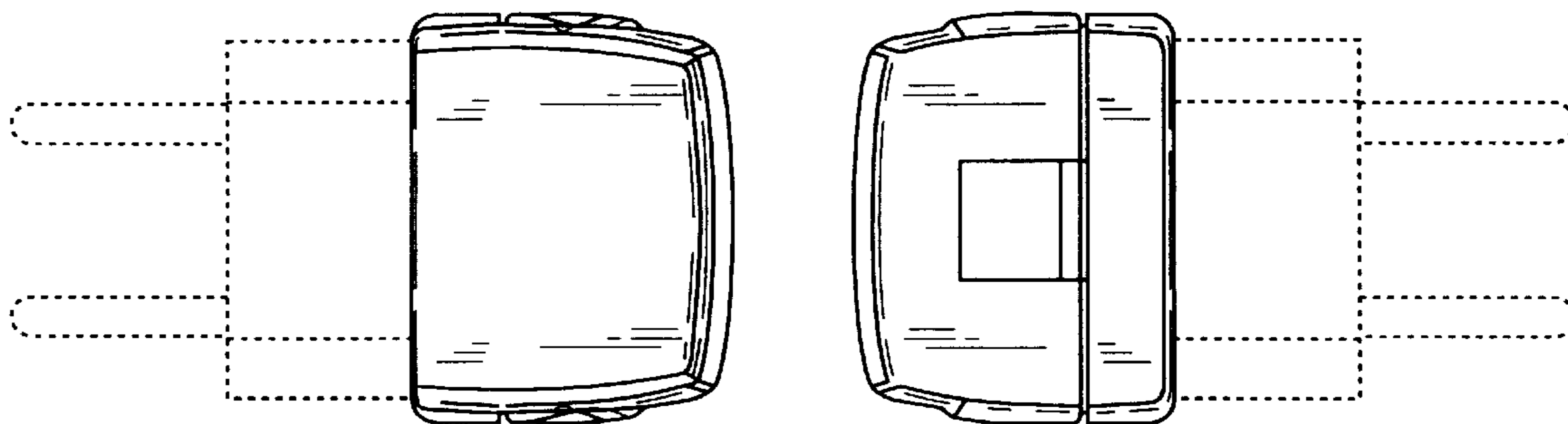
**FIG. 7**



**FIG. 8**

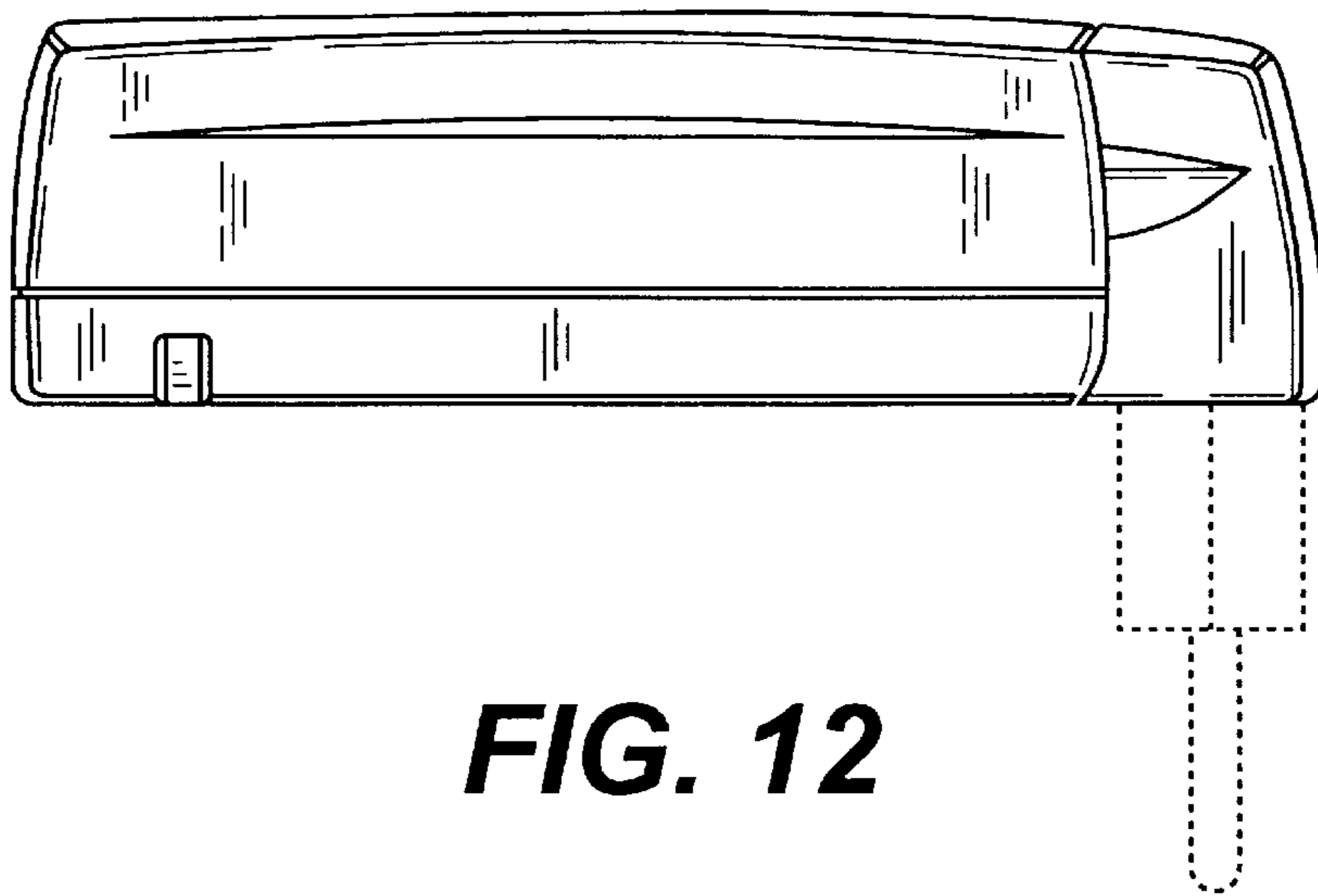


**FIG. 9**

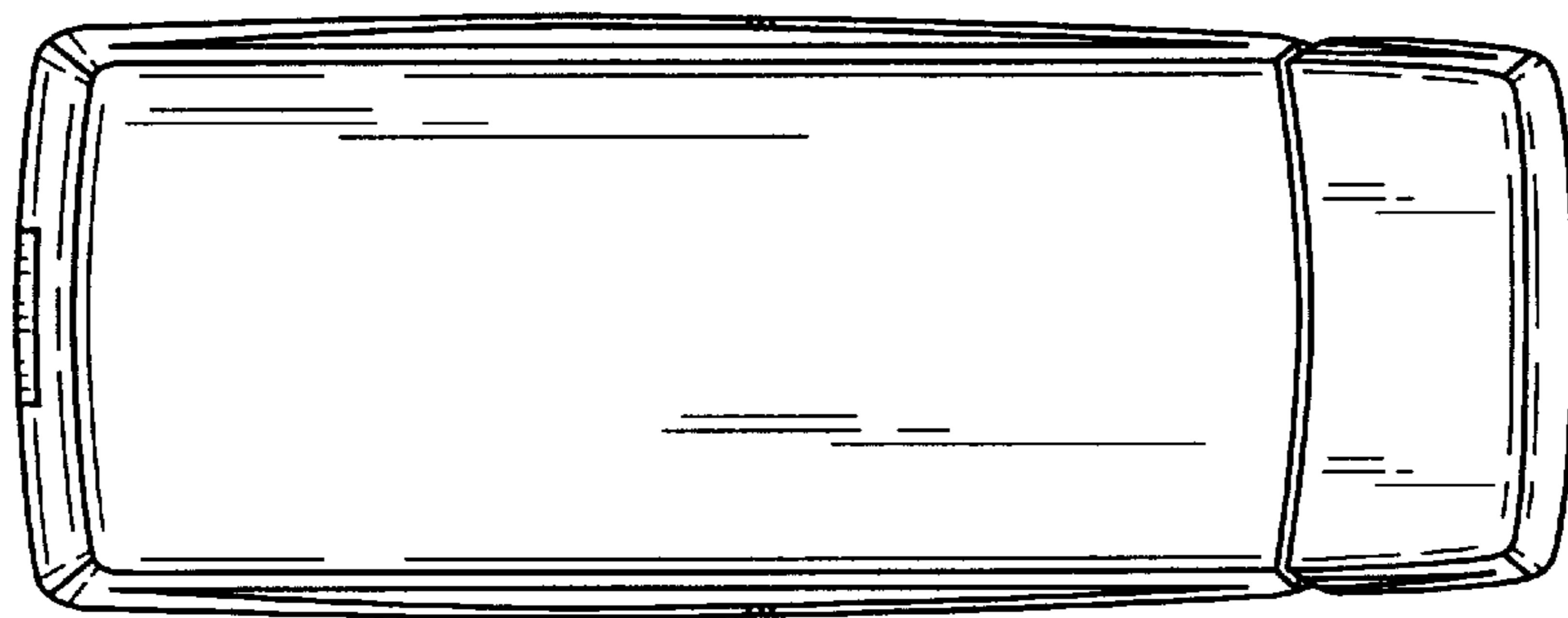


**FIG. 10**

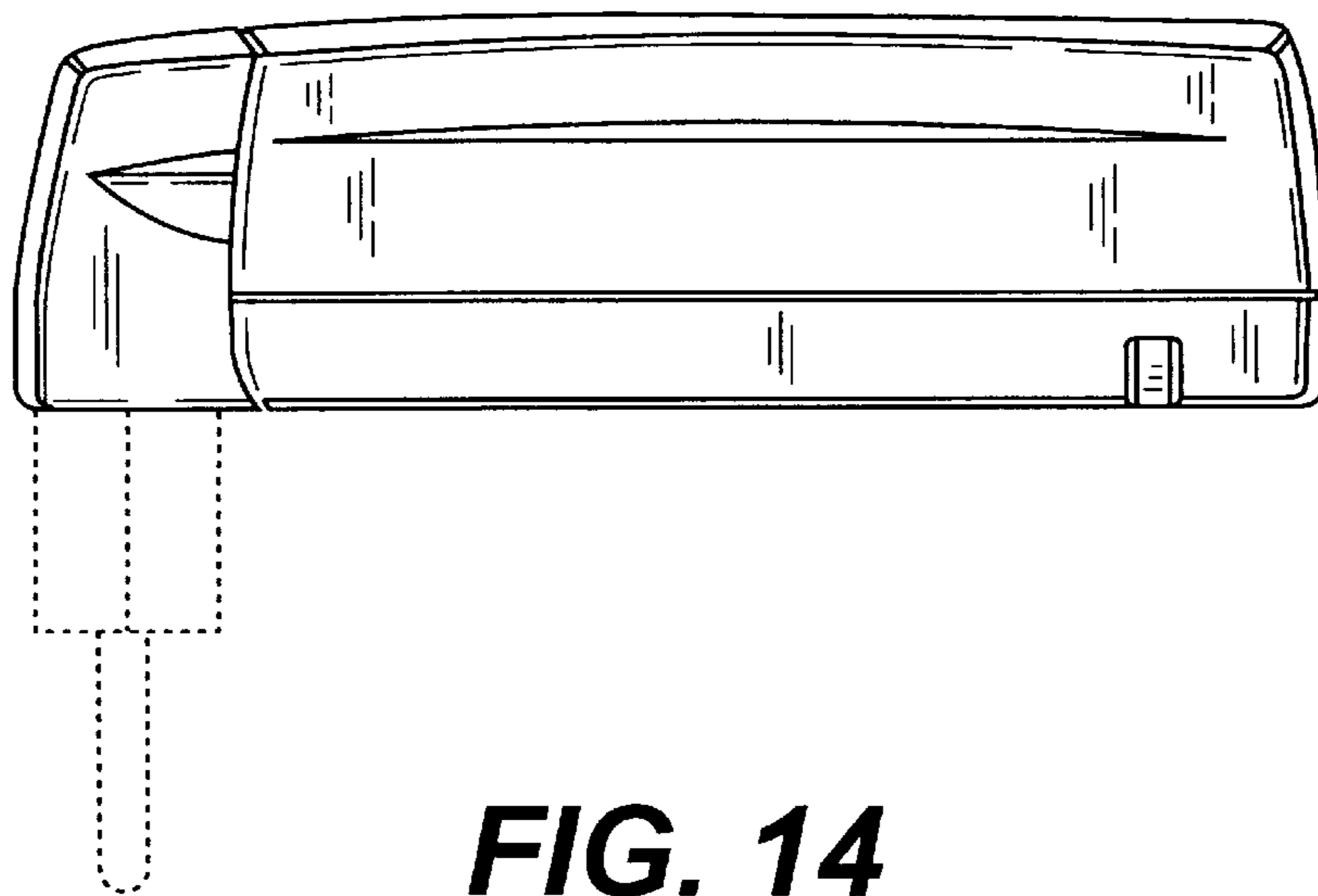
**FIG. 11**



**FIG. 12**

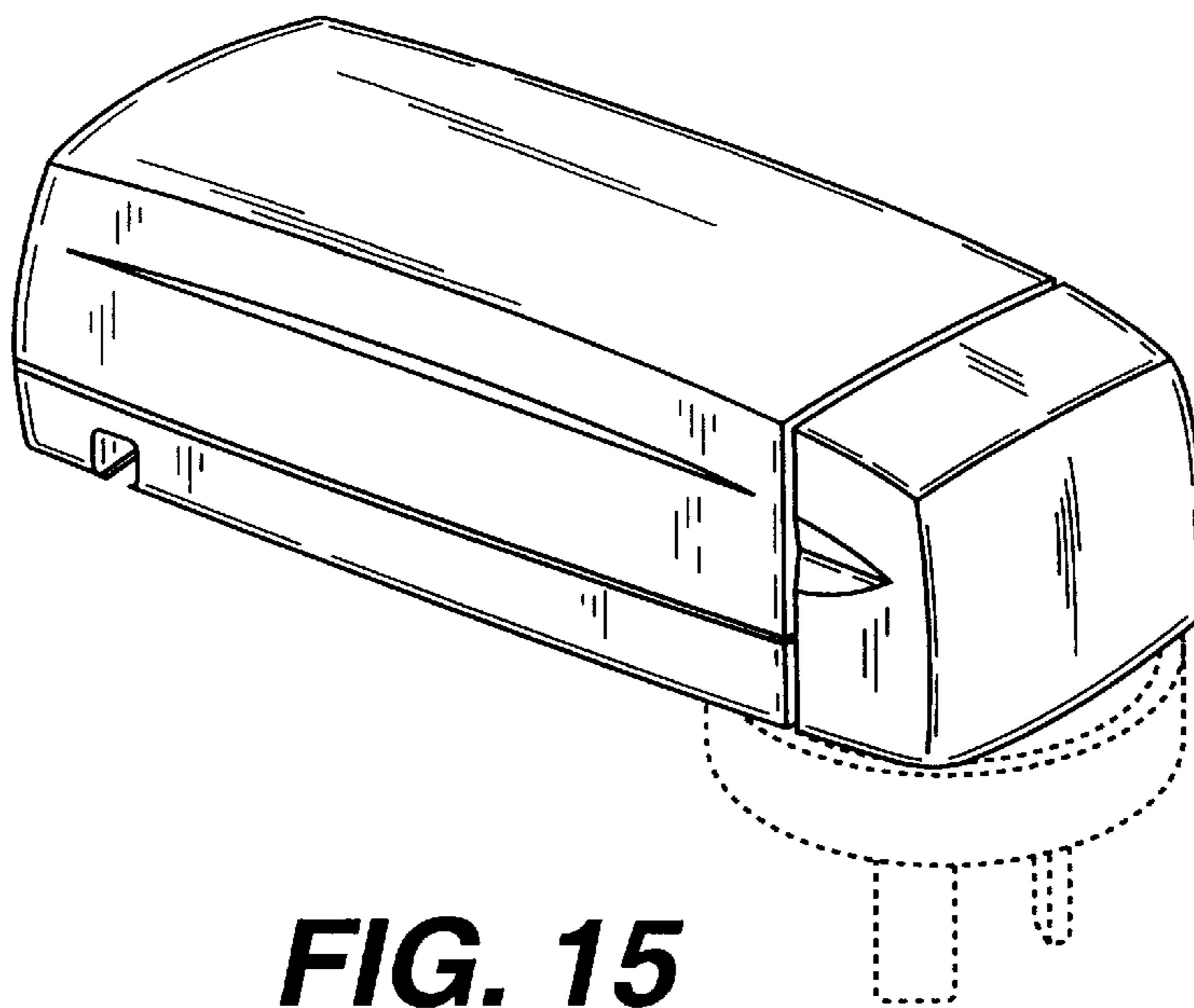


**FIG. 13**

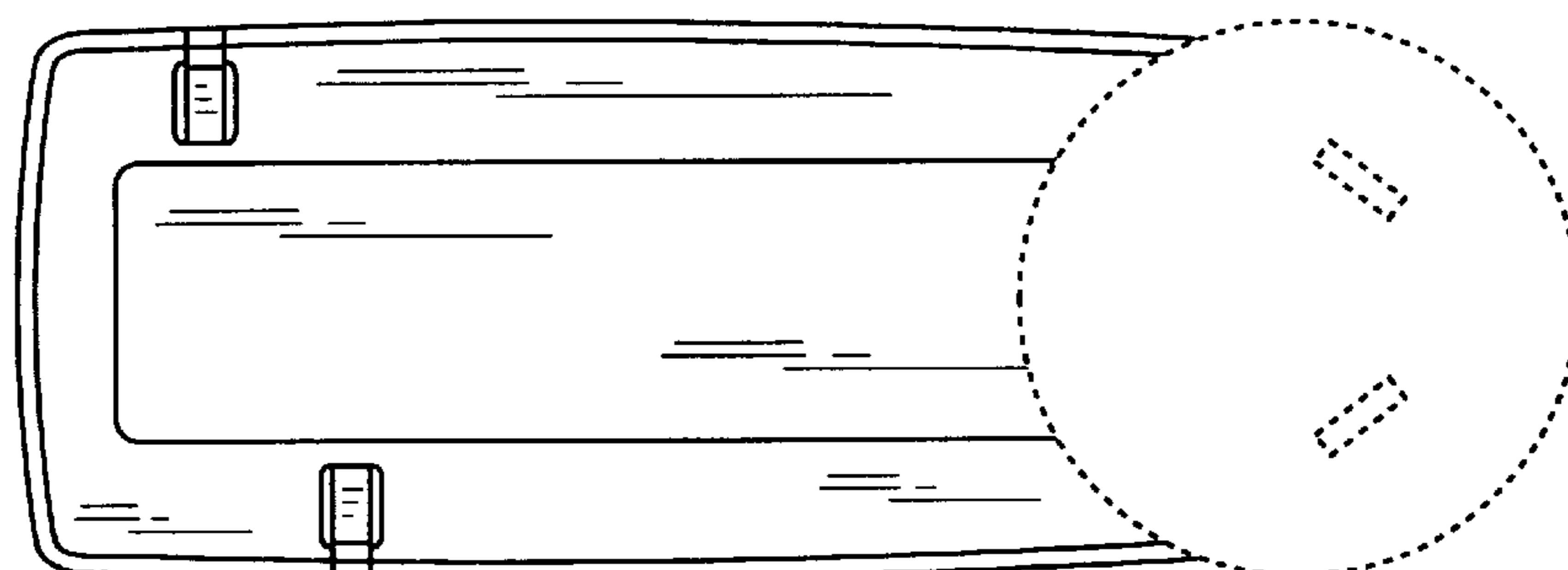


**FIG. 14**

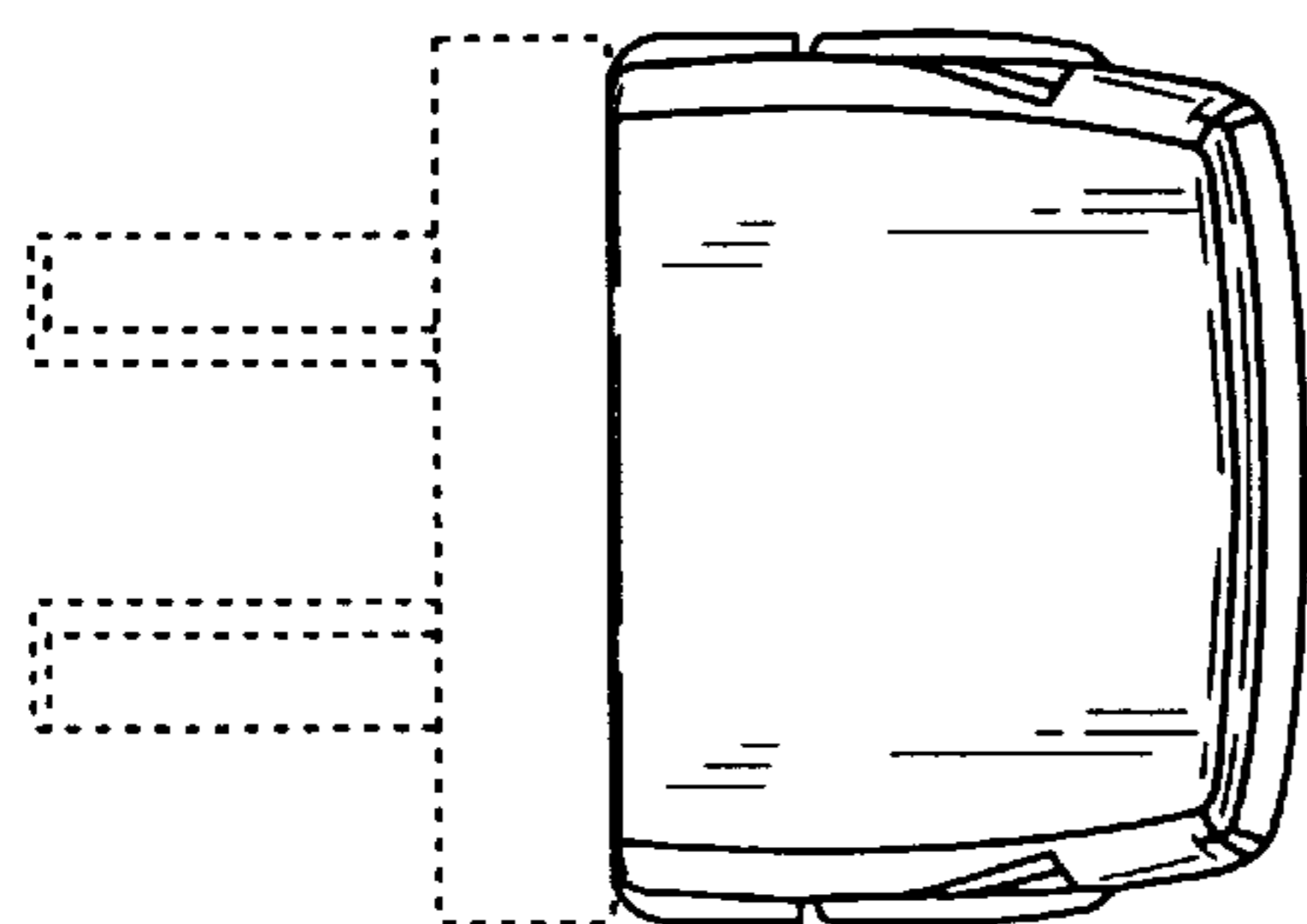




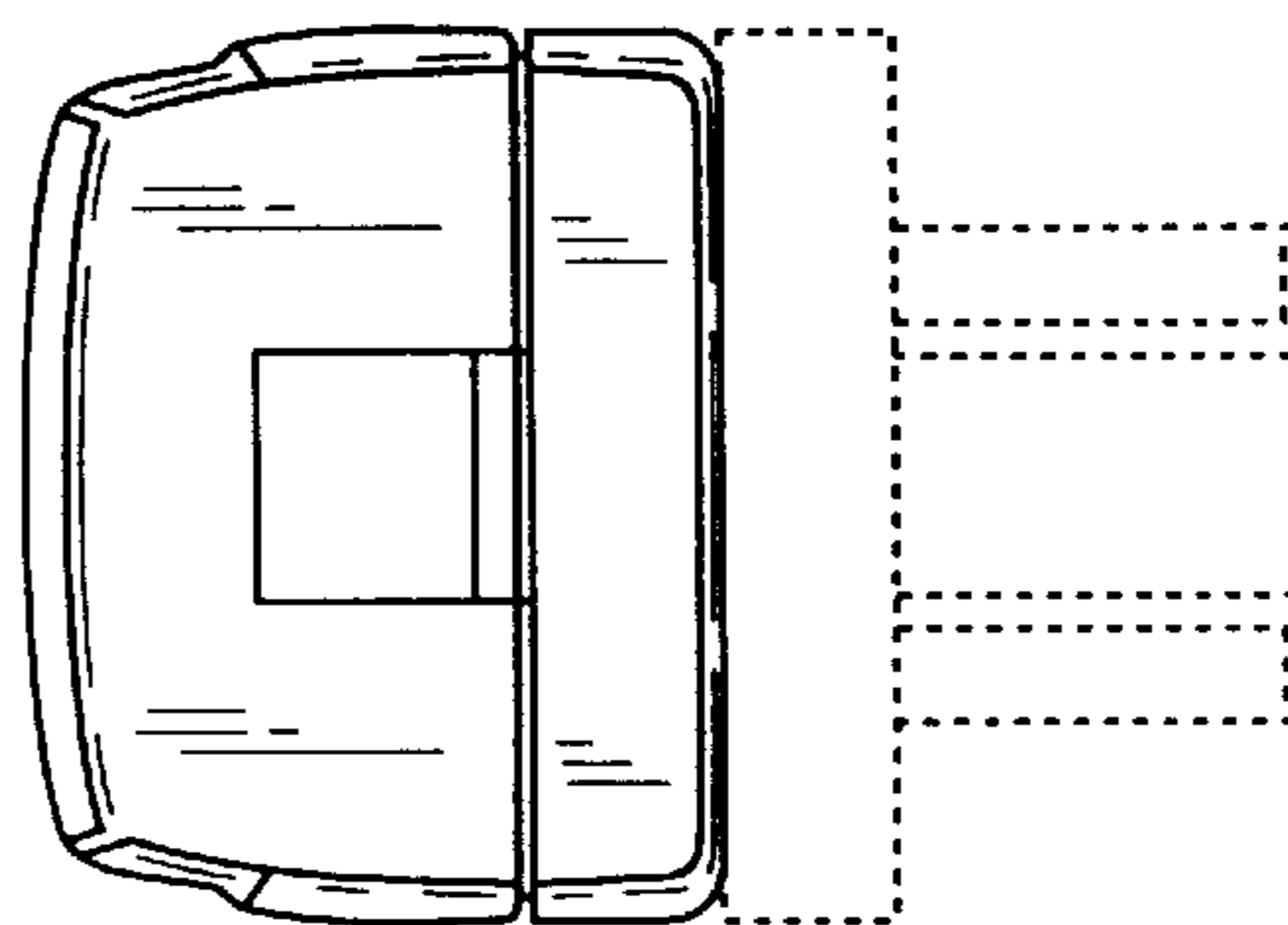
**FIG. 15**



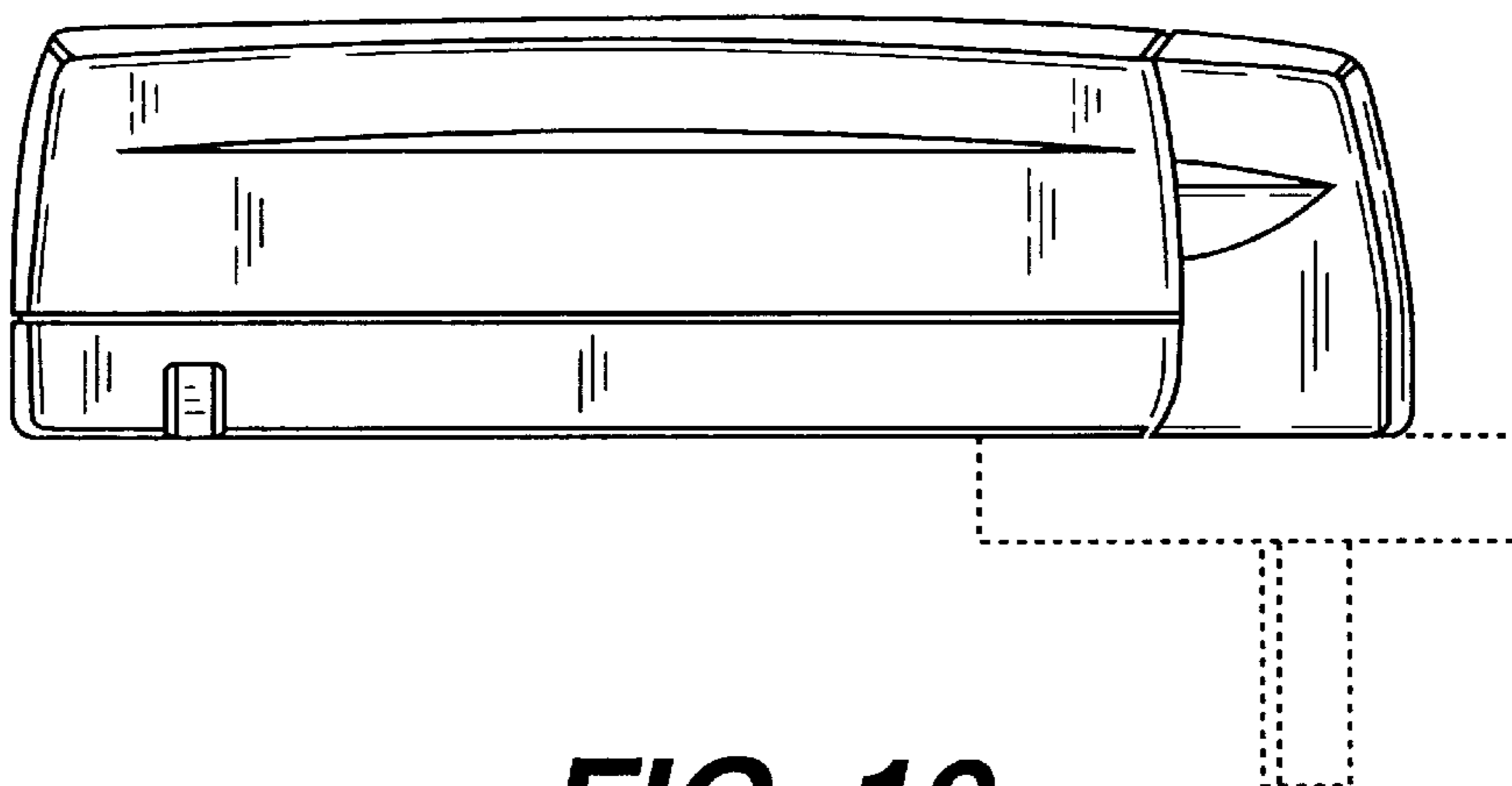
**FIG. 16**



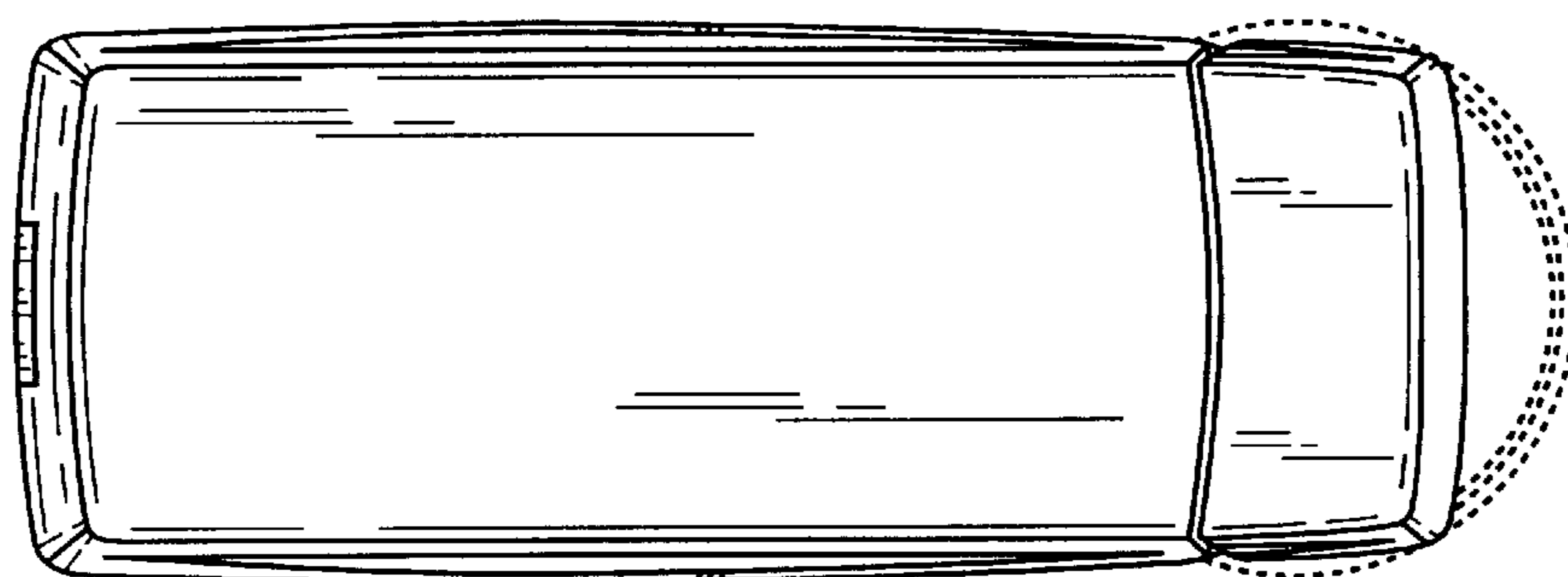
**FIG. 17**



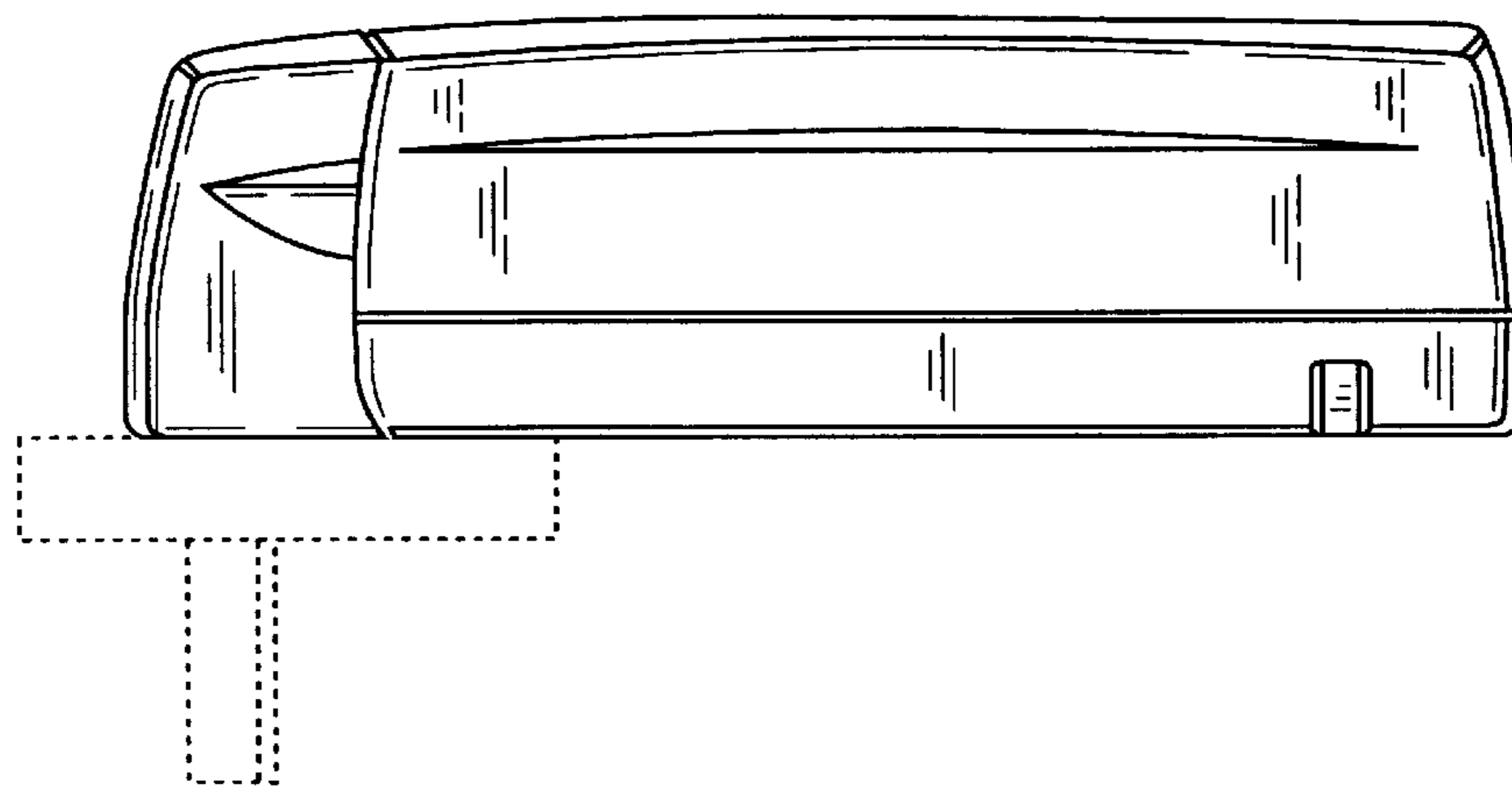
**FIG. 18**



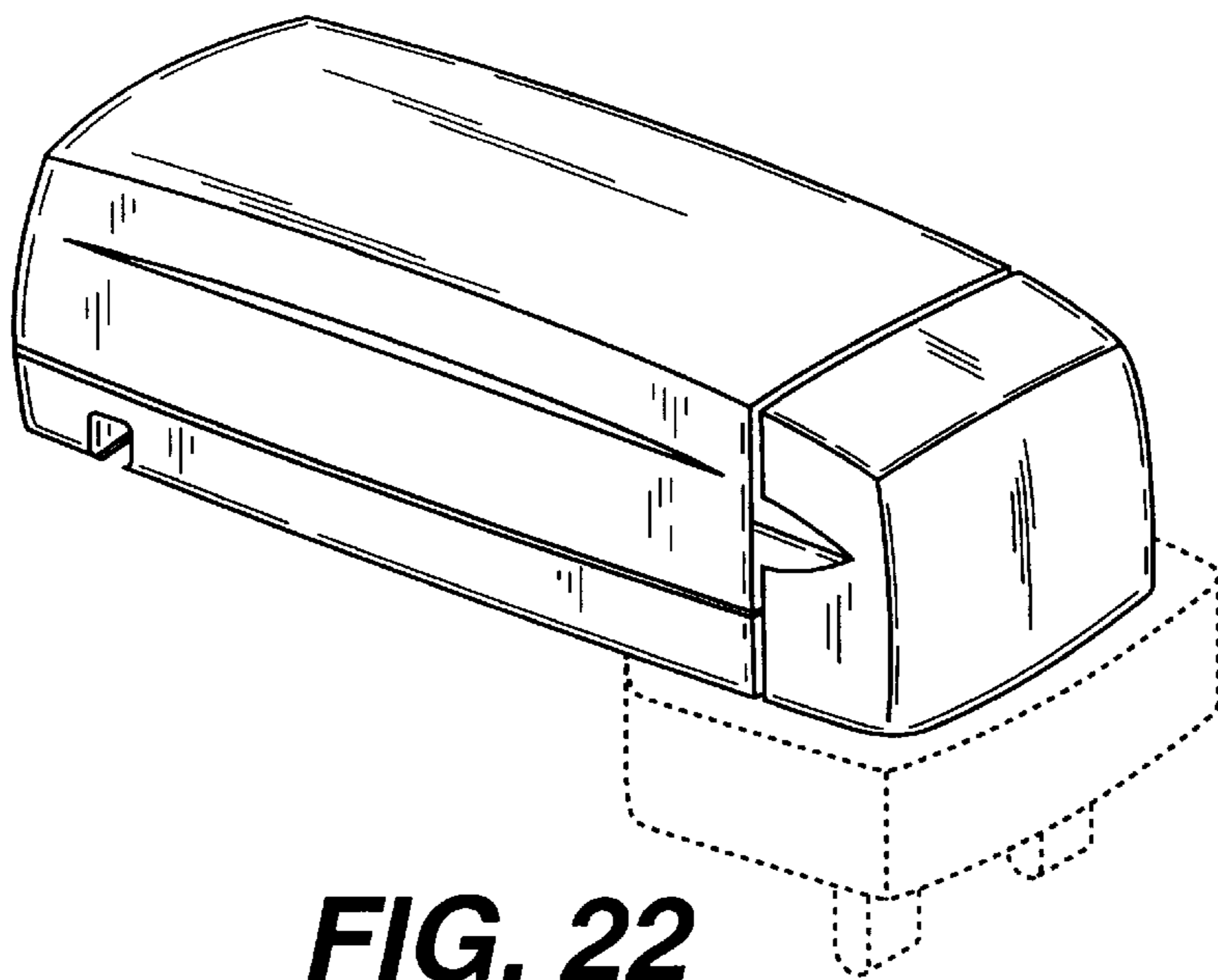
**FIG. 19**



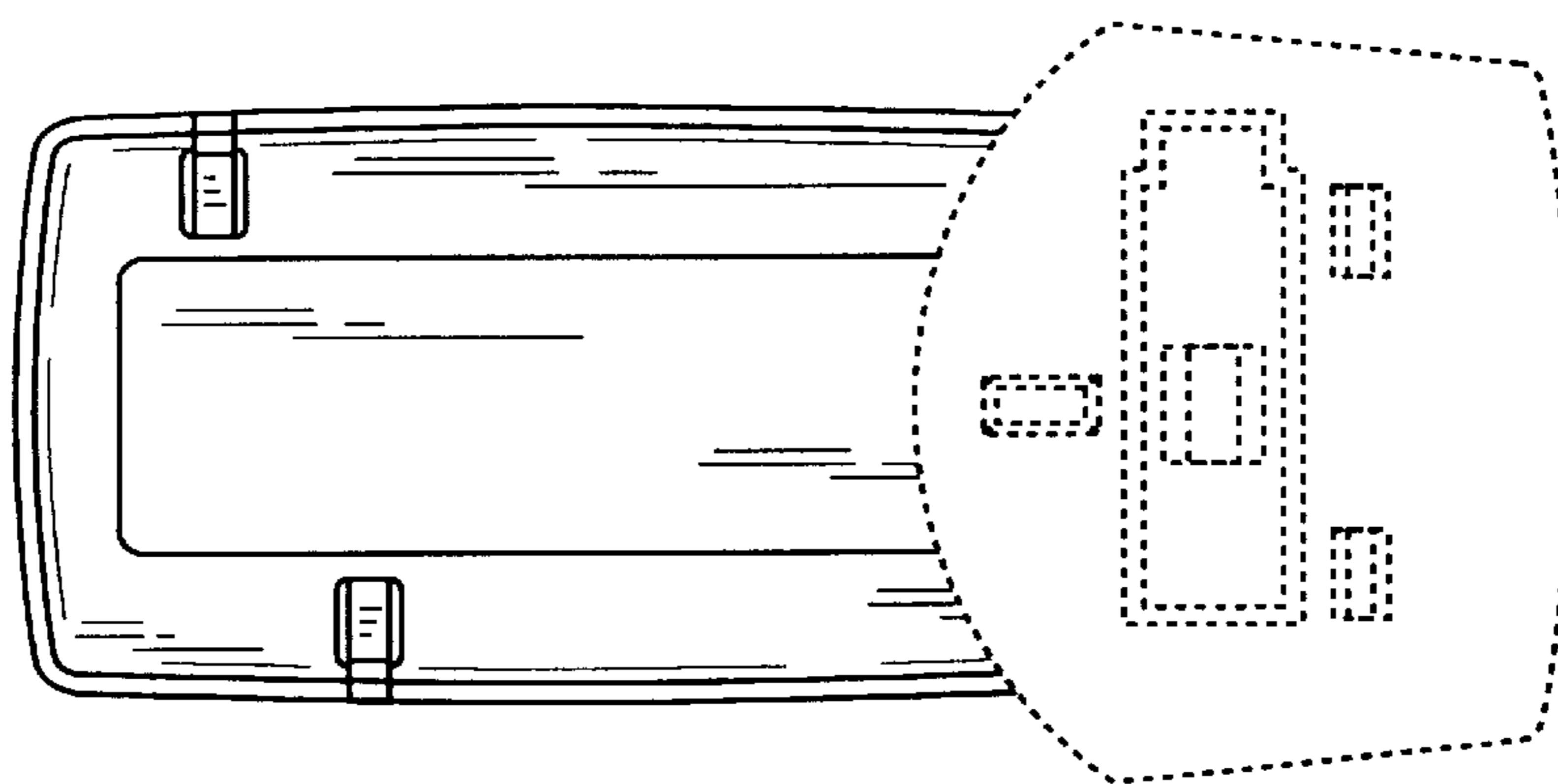
**FIG. 20**



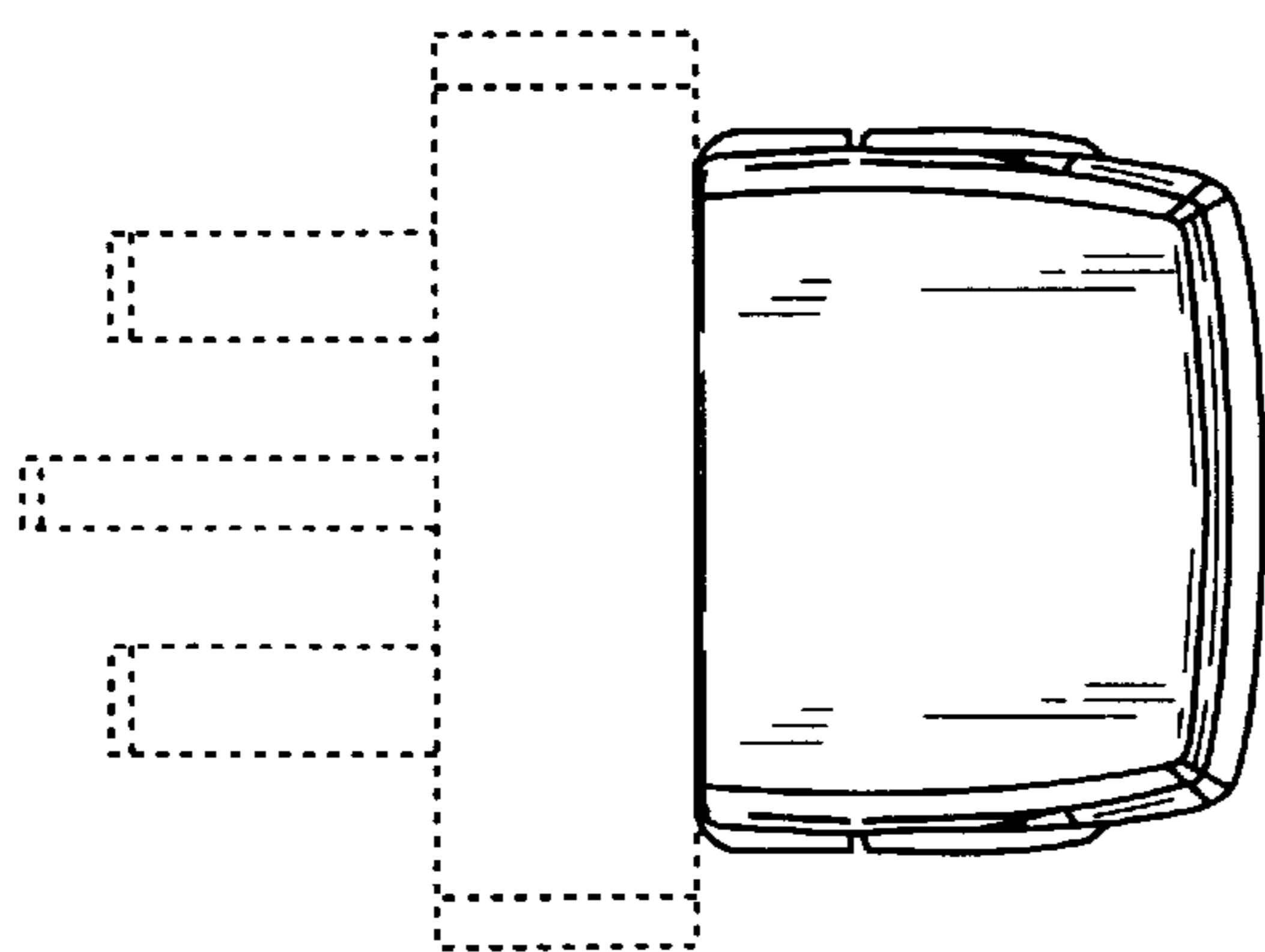
**FIG. 21**



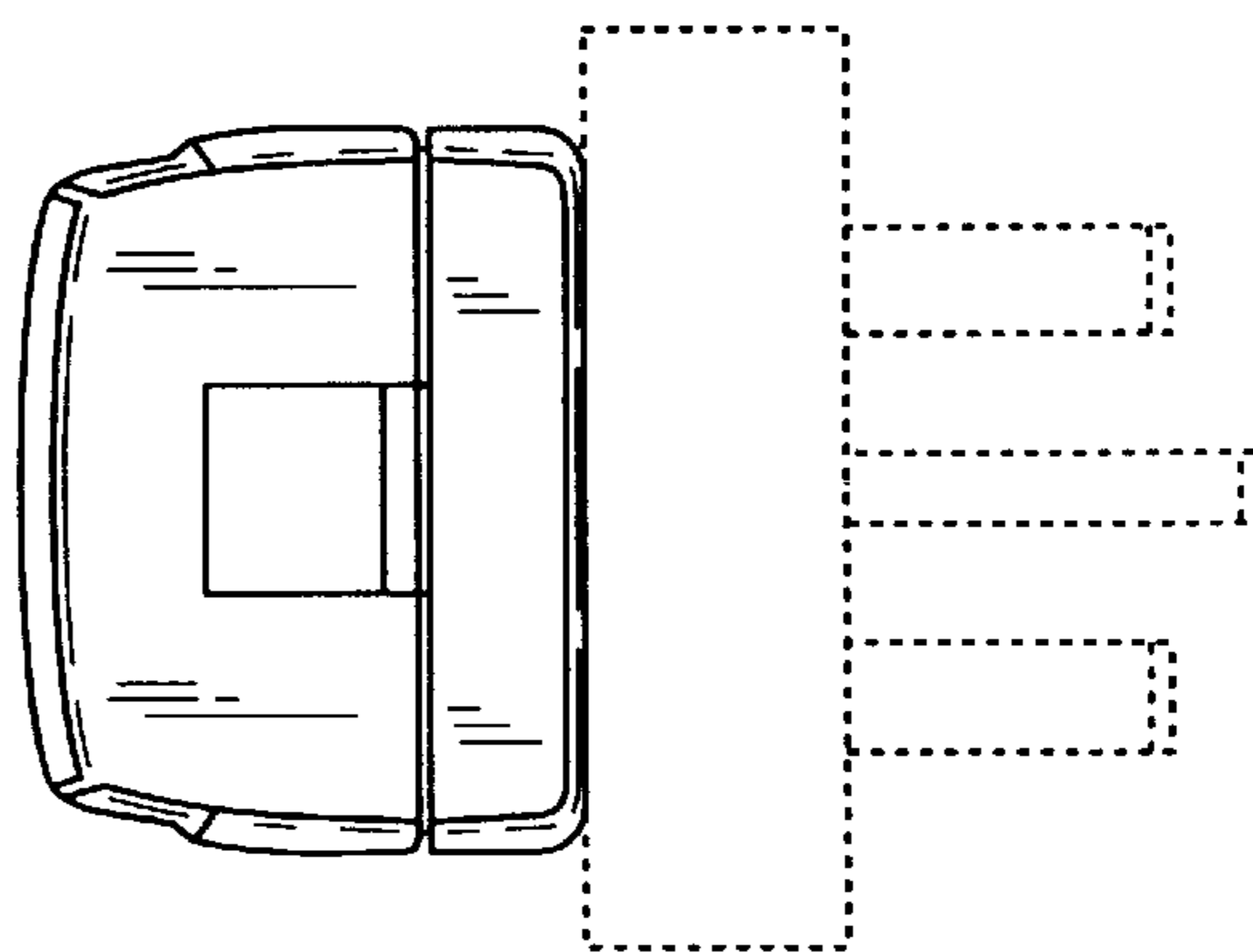
**FIG. 22**



**FIG. 23**

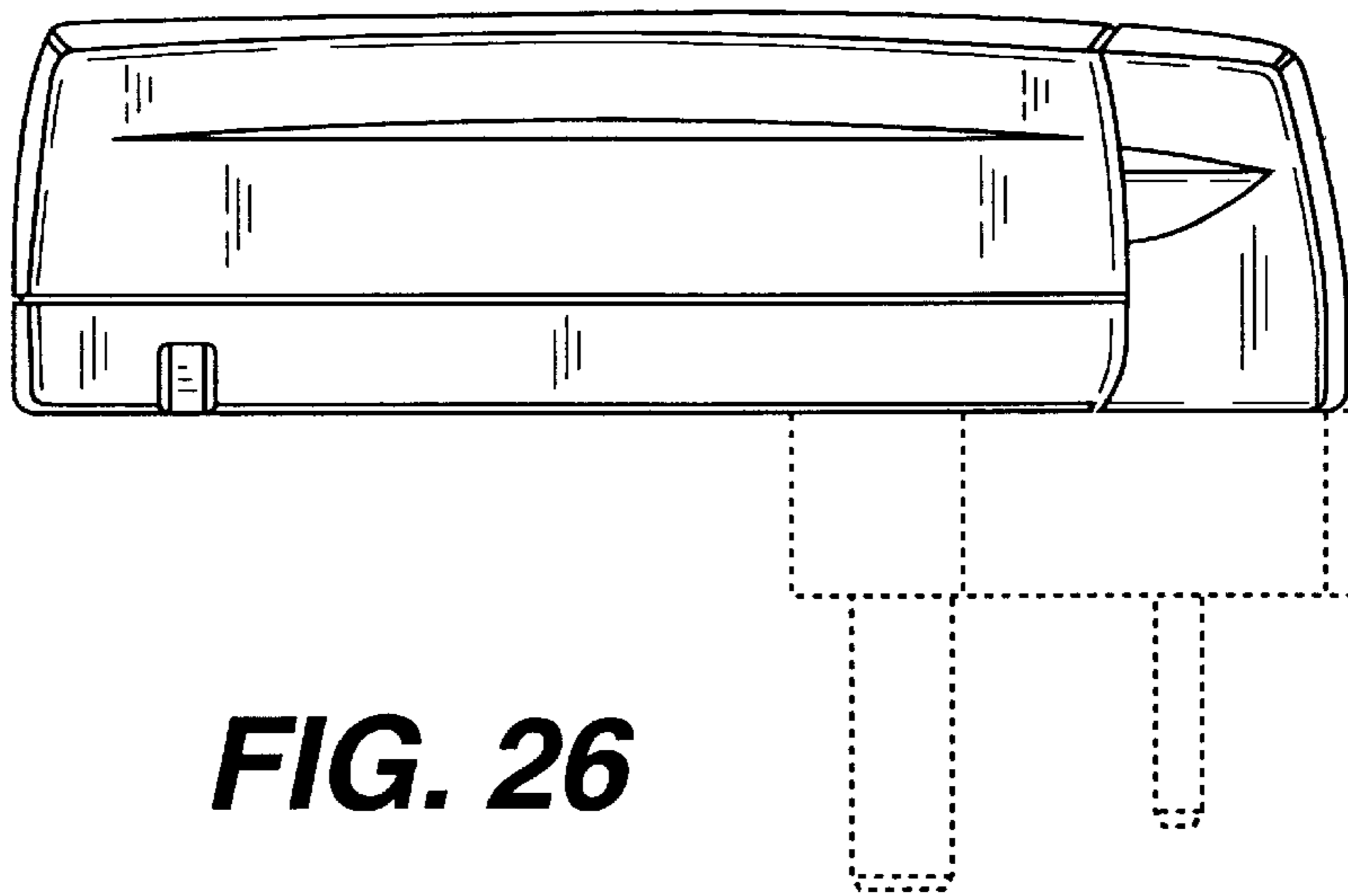


**FIG. 24**

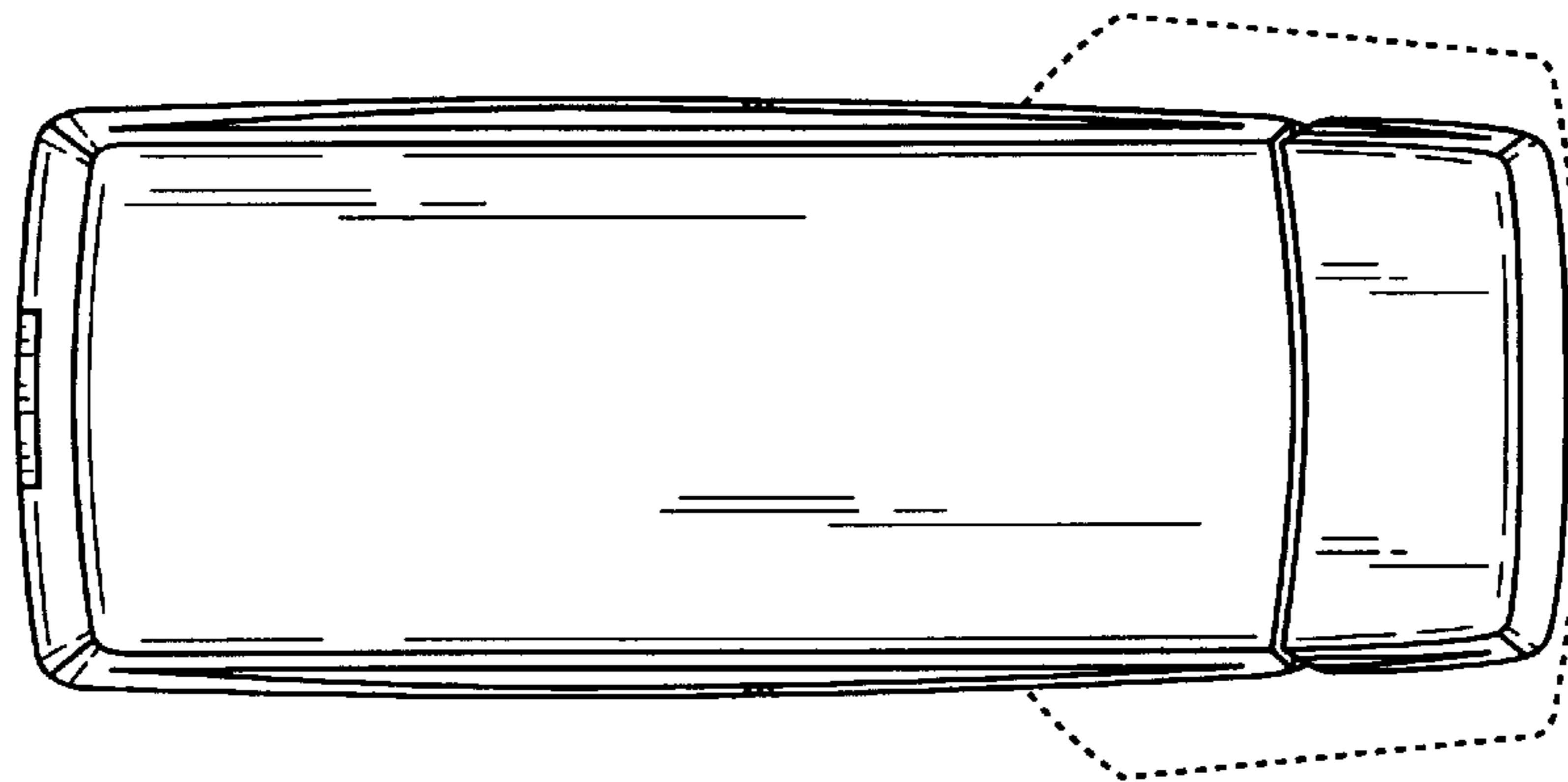


**FIG. 25**

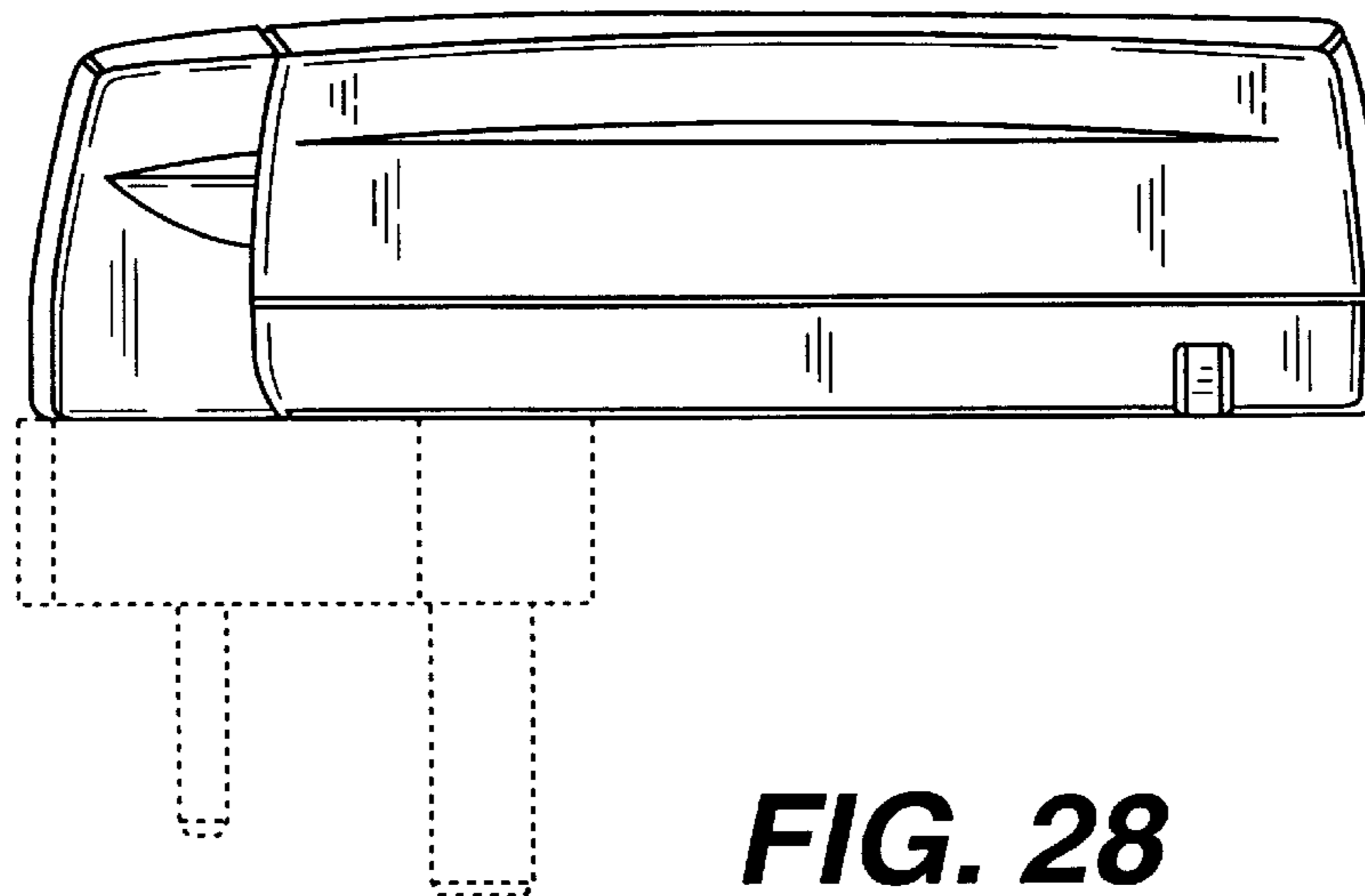




**FIG. 26**



**FIG. 27**



**FIG. 28**