



US00D434356S

United States Patent [19] Giard

[11] Patent Number: Des. 434,356

[45] Date of Patent: ** Nov. 28, 2000

[54] BICYCLE HANDLEBAR BAR ENDS

[75] Inventor: Edward Giard, Sun Prairie, Wis.

[73] Assignee: Trek Bicycle Corporation, Waterloo, Wis.

[**] Term: 14 Years

[21] Appl. No.: 29/090,597

[22] Filed: Jul. 13, 1998

[51] LOC (7) Cl. 12-16

[52] U.S. Cl. D12/178

[58] Field of Search D12/114, 111,
D12/178; 74/551.1, 551.3, 551.7-551.9

[56] References Cited

U.S. PATENT DOCUMENTS

D. 214,114	5/1969	Clarke	D12/178
D. 340,432	10/1993	Osborne	D12/114
D. 342,050	12/1993	Gustafsson	D12/178
D. 362,418	9/1995	Li	D12/114
D. 366,015	1/1996	McCormack	D12/114
D. 376,124	12/1996	Bernloehr	D12/178
D. 397,069	8/1998	Newkirk	D12/178
5,390,564	2/1995	Klieber	74/551.1
5,421,220	6/1995	Chen	74/551.8

OTHER PUBLICATIONS

Oct. 1995 Issue *BMX PLUS!* magazine: cover page and 11 select pages (7 unidentified and pp. 25, 33, 80, 82).
Kalloy Industrial Co., Ltd. drawing, no. Feb. 6, 1985.

O'Neils 25 anniversary Bike Shop catalog, p. 45, the Bon-trager Race w/Ski Bend aluminum bar ends, Jul. 1, 1997. Excels Sports Boulder, ©1997 p. 68, Ritchey Logic Pro bicycle bar ends.

Colorado Cyclist, Spr. 1998, p. 63, the Control Tech Team Issue Bar Ends & Profile Briefs, Boxer Bar Ends.

Performance Elite, Early Summer 1998, p. X, the Omza Stogies & Omza CWA Pro Cut Bar Ends.

Primary Examiner—Melody N. Brown

Attorney, Agent, or Firm—Boyle Fredrickson Ziolkowski S.C.; James F. Boyle

[57] CLAIM

The ornamental design for a bicycle handlebar bar ends, as shown and described.

DESCRIPTION

FIG. 1 is a top view of a left bicycle handlebar bar end showing my new design;

FIG. 2 is a side view of the left bar end.

FIG. 3 is a bottom view of the left bar end.

FIG. 4 is a side view (opposite FIG. 2) of the left bar end.

FIG. 5 is a rear view of the left bar end.

FIG. 6 is a front view of the left bar end; and,

FIG. 7 is a perspective view of the right and left bicycle handlebar bar ends, the portions of the bicycle shown in broken lines are for illustrative purposes only and form no part of the claimed design.

1 Claim, 3 Drawing Sheets

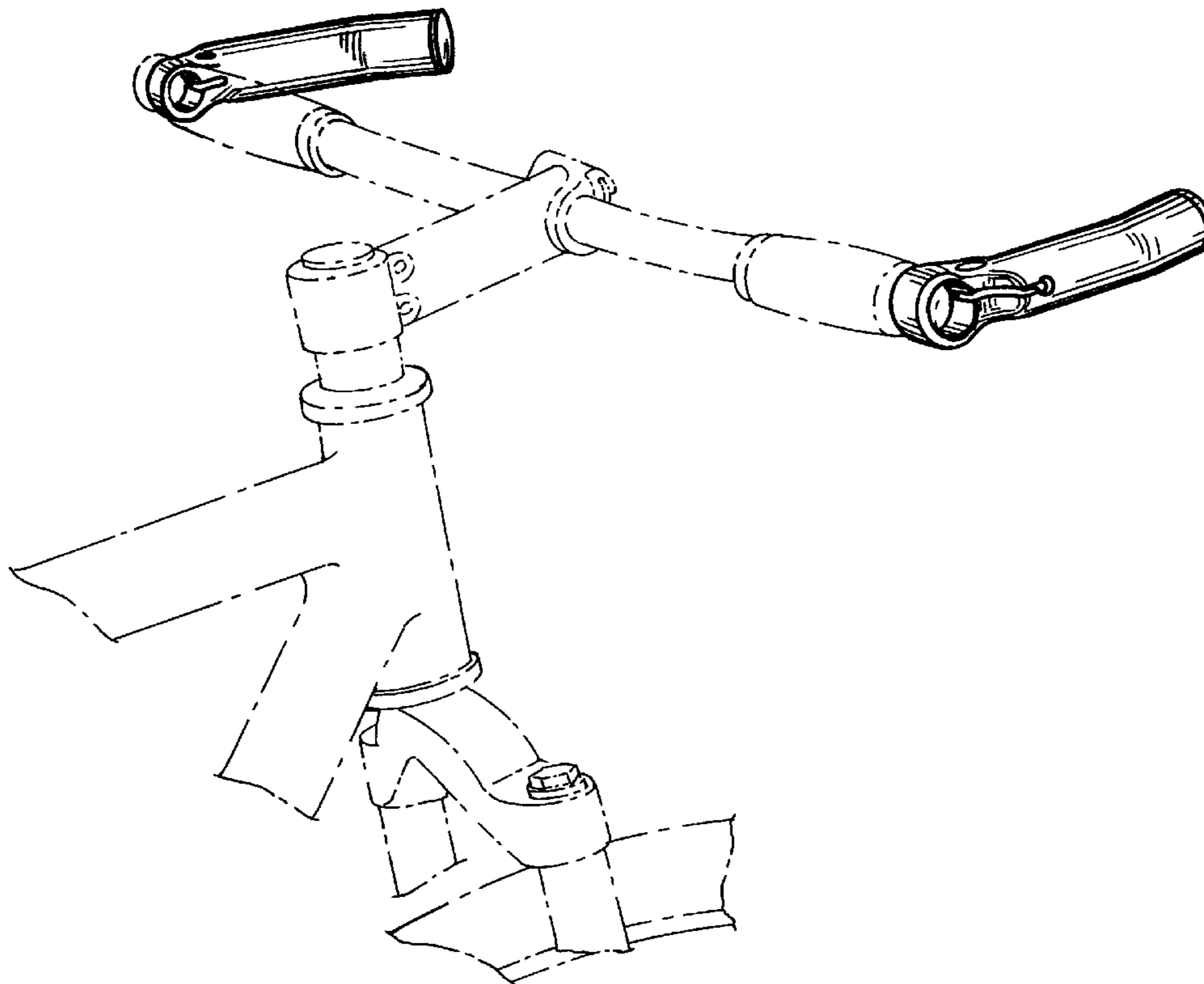

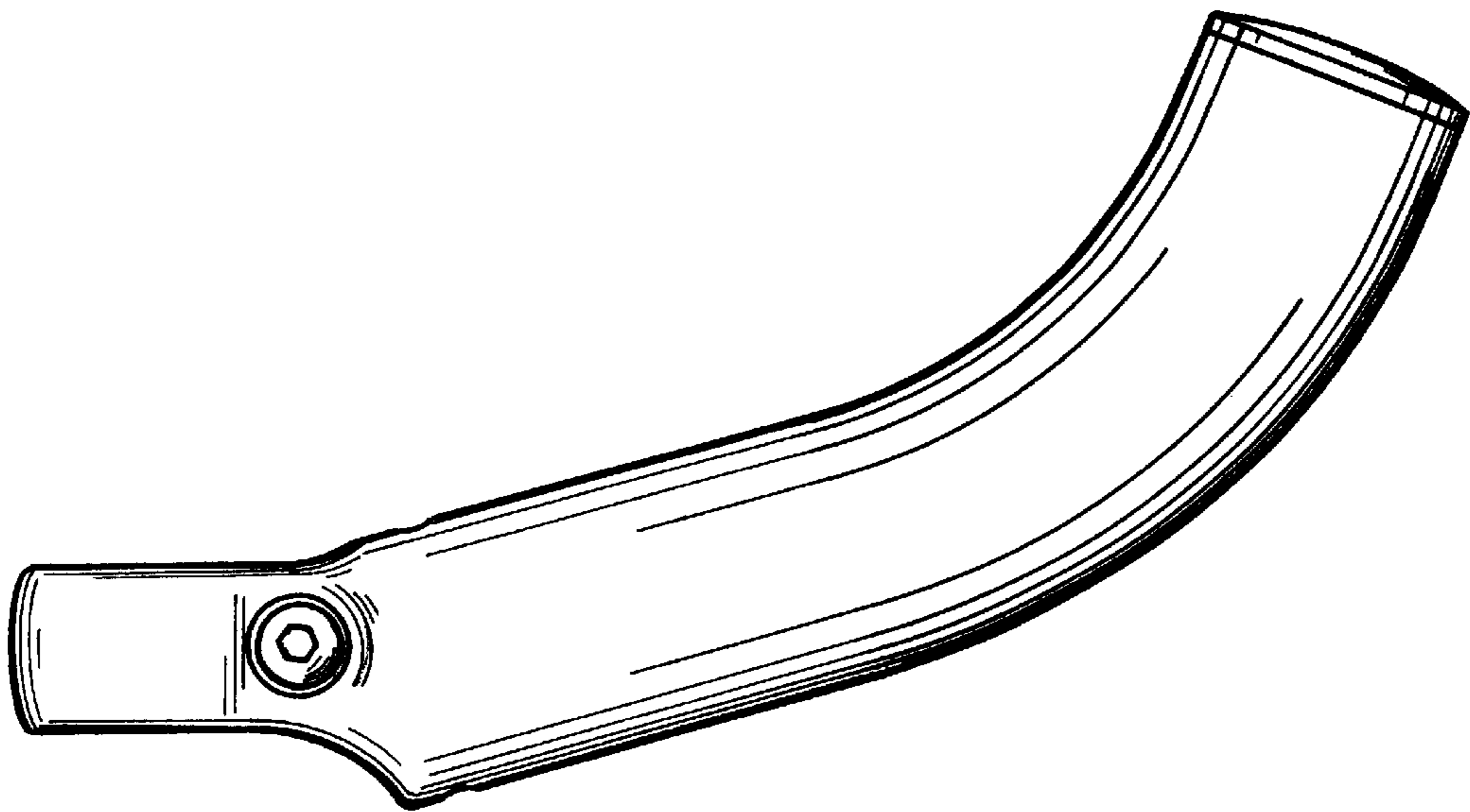

FIG. 1

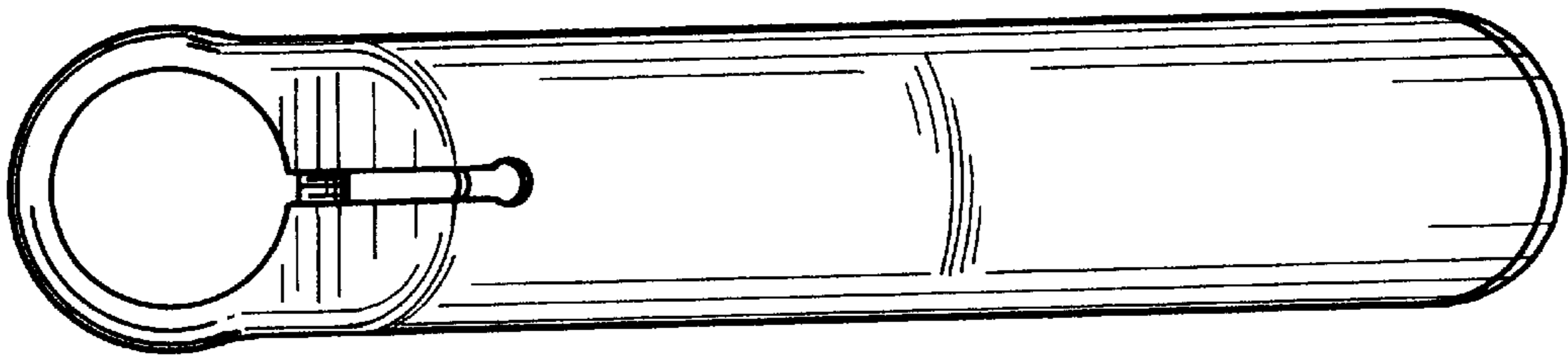

FIG. 2

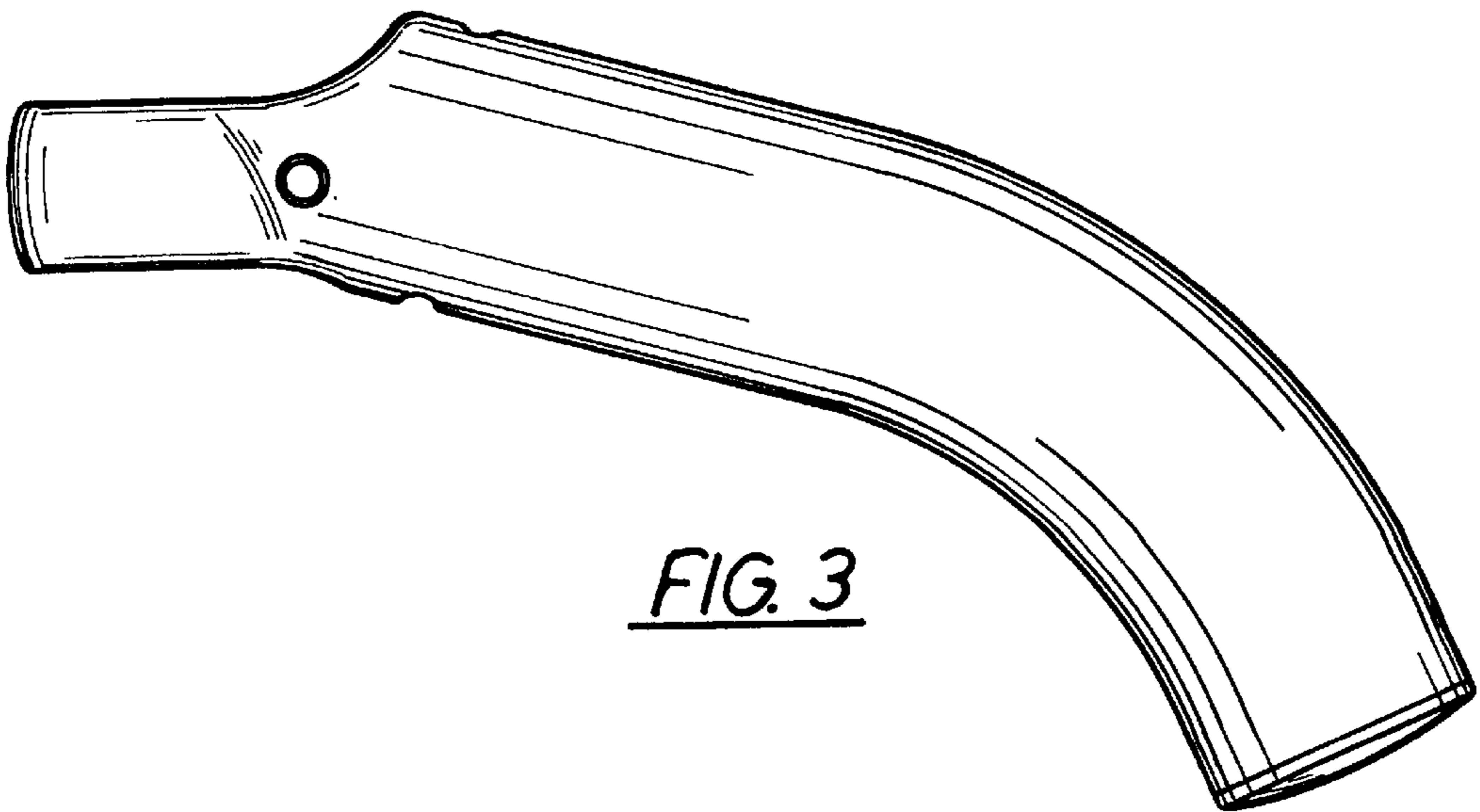

FIG. 3

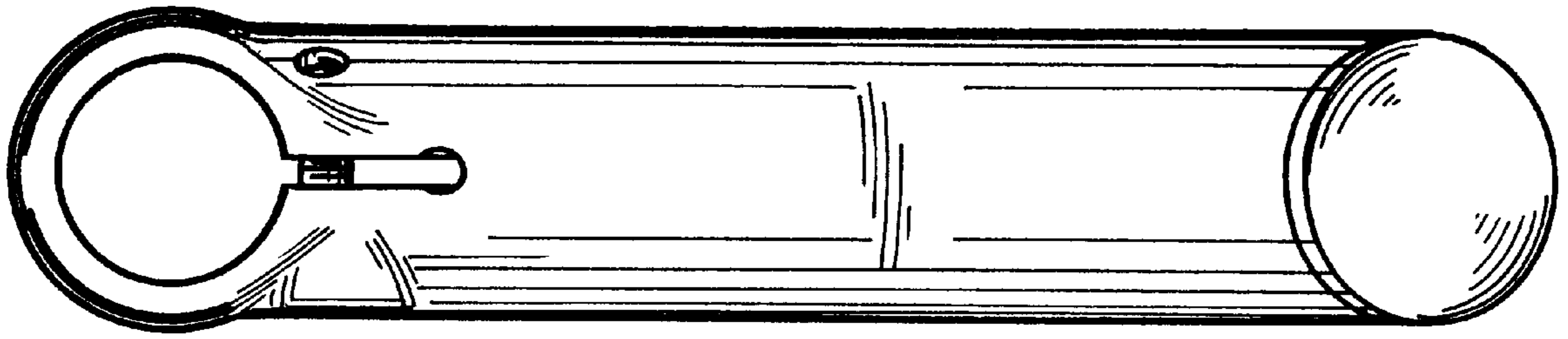

FIG. 4

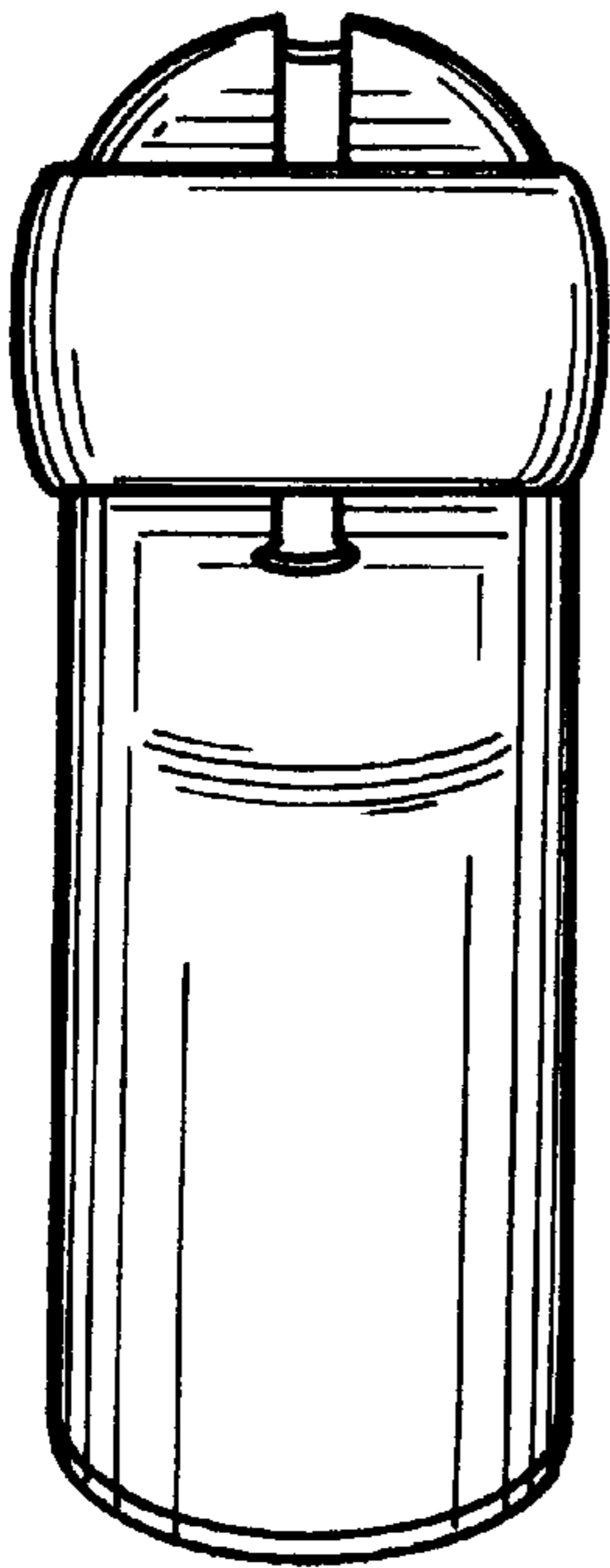

FIG. 5

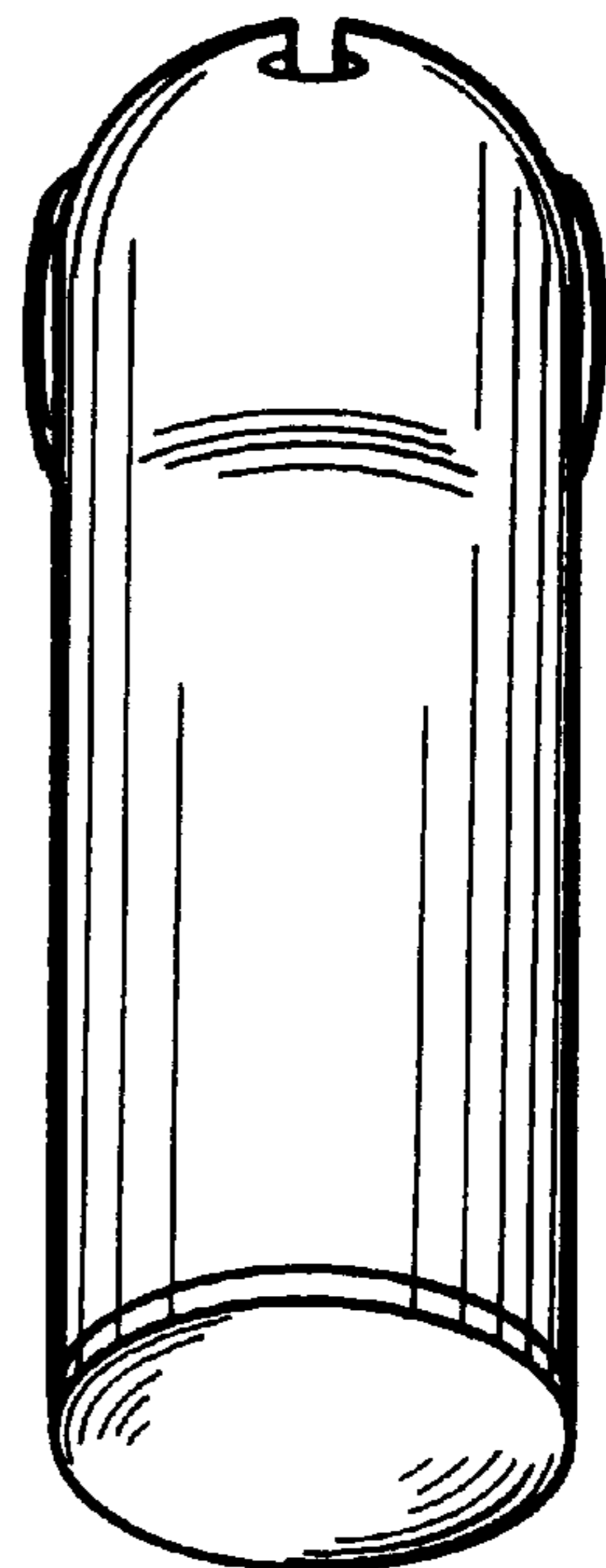

FIG. 6

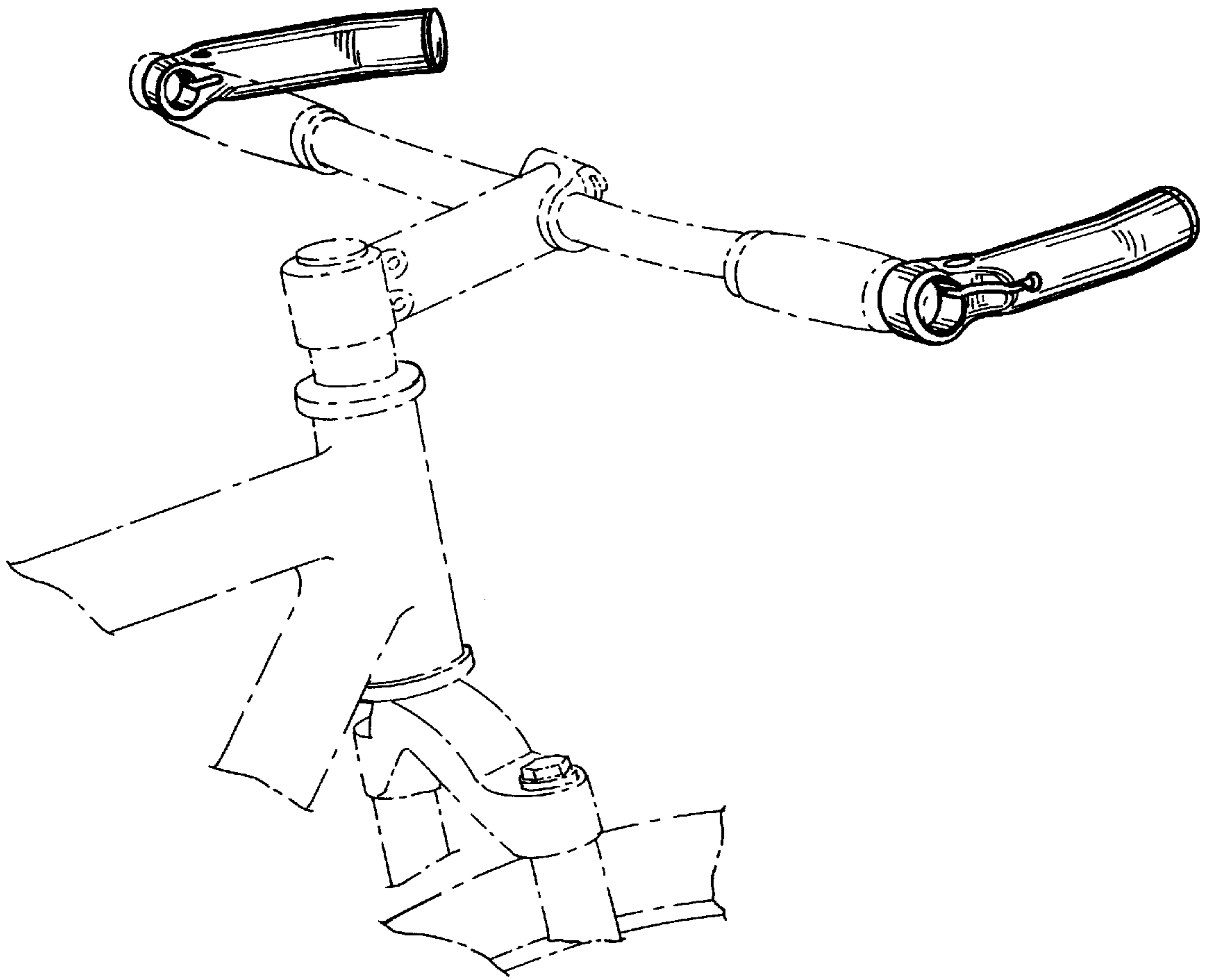

FIG. 7