



US00D434347S

United States Patent [19]

[11] Patent Number: Des. 434,347

Damon et al.

[45] Date of Patent: ** Nov. 28, 2000

[54] ROOF FOR A TRUCK

[75] Inventors: **Kenneth H. Damon**, Fort Worth; **Louis D. Heilaneh**; **Anthony M. Weiblen**, both of Lewisville, all of Tex.

[73] Assignee: **PACCAR Inc**, Bellevue, Wash.

[**] Term: **14 Years**

[21] Appl. No.: **29/103,771**

[22] Filed: **Apr. 20, 1999**

[51] LOC (7) Cl. **12-08**

[52] U.S. Cl. **D12/96**

[58] Field of Search D12/96, 196, 181; 296/180.1, 180.2, 37.7, 181; 180/90

[56] **References Cited**

U.S. PATENT DOCUMENTS

D. 271,864	12/1983	Kangas	D12/96
D. 272,058	1/1984	Kangas	D12/156
D. 311,506	10/1990	Marlowe et al.	D12/96
D. 311,712	10/1990	Marlowe et al.	D12/96
D. 312,805	12/1990	Marlowe et al.	D12/96
D. 313,966	1/1991	Marlowe et al.	D12/181
D. 320,583	10/1991	Simons et al.	D12/96
D. 329,214	9/1992	Marlowe et al.	D12/96
D. 343,597	1/1994	Meryman et al.	D12/97
D. 384,914	10/1997	Bingaman	D12/97
D. 385,223	10/1997	Marlowe et al.	D12/96
D. 391,524	3/1998	Anderson et al.	D12/96
D. 397,963	9/1998	Hurayt et al.	D12/96
D. 399,791	10/1998	Hellhake et al.	D12/96
D. 399,792	10/1998	Hellhake et al.	D12/96
D. 400,158	10/1998	Meryman et al.	D12/401
4,957,322	9/1990	Marlowe et al.	296/180.2
5,560,673	10/1996	Angelo	296/190

Primary Examiner—Melody N. Brown
Attorney, Agent, or Firm—Sidley & Austin

[57] **CLAIM**

The ornamental design for a roof for a truck, as shown and described.

DESCRIPTION

FIG. 1 is a perspective view of a first embodiment of our roof for a truck;
 FIG. 2 is a front view thereof;
 FIG. 3 is a left side view thereof;
 FIG. 4 is a rear view thereof;
 FIG. 5 is a right side view thereof;
 FIG. 6 is a top view thereof;
 FIG. 7 is a perspective view of our invention showing the environment in which it can be used;
 FIG. 8 is a perspective view of a second embodiment of our roof for a truck;
 FIG. 9 is a front view of FIG. 8;
 FIG. 10 is a left side view of FIG. 8;
 FIG. 11 is a rear view of FIG. 8;
 FIG. 12 is a right side view of FIG. 8;
 FIG. 13 is a top view of FIG. 8;
 FIG. 14 is a perspective view of a third embodiment of our roof for a truck;
 FIG. 15 is a front view of FIG. 14;
 FIG. 16 is a left side view of FIG. 14;
 FIG. 17 is a rear view of FIG. 14;
 FIG. 18 is a right side view of FIG. 14; and,
 FIG. 19 is a top view of FIG. 14.

The appearance of the roof underside forms no part of the claimed design. In addition, the broken line showing of a truck, in FIG. 7, is for illustrative purposes only and forms no part of the claimed design.

1 Claim, 5 Drawing Sheets

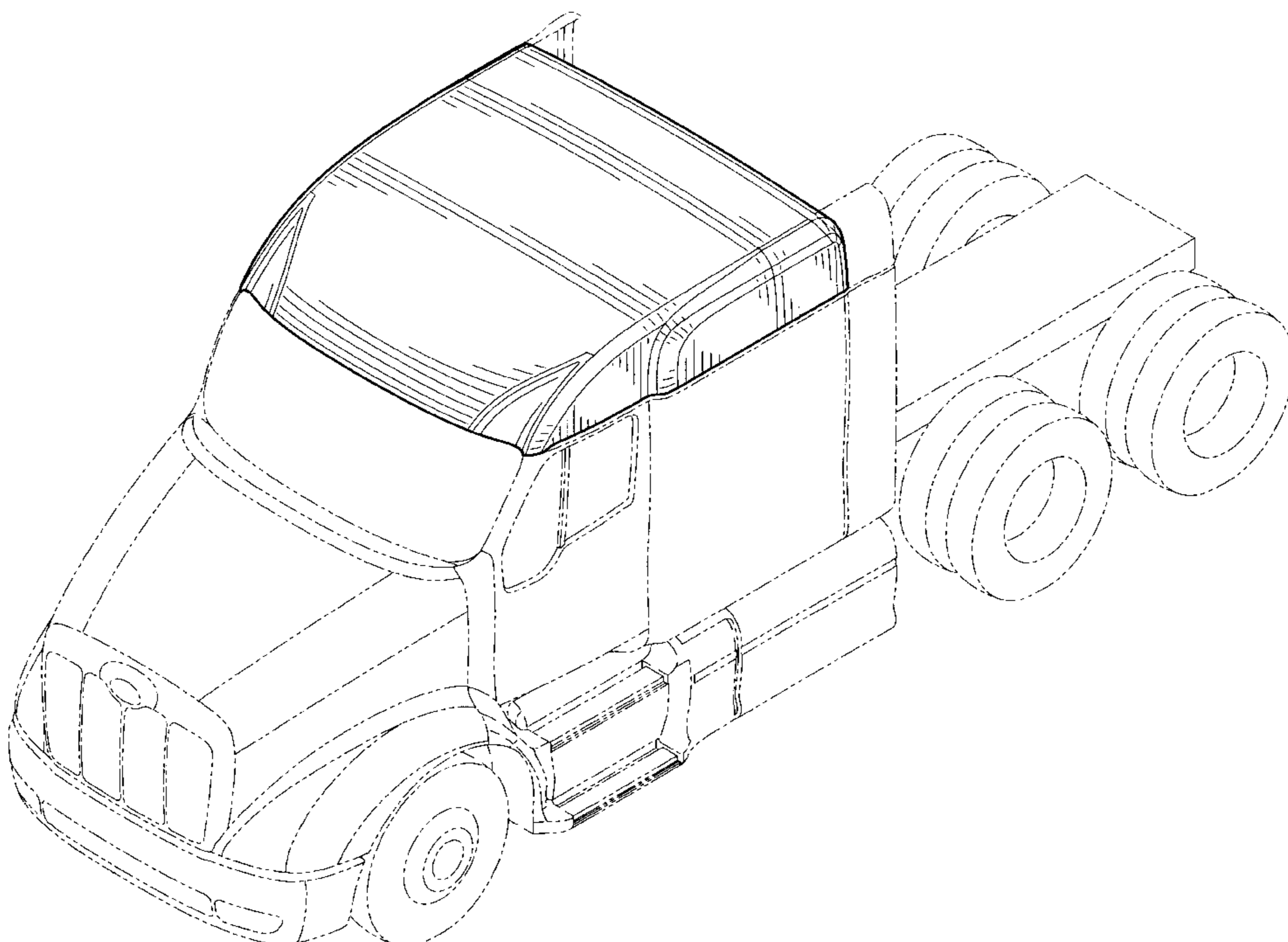

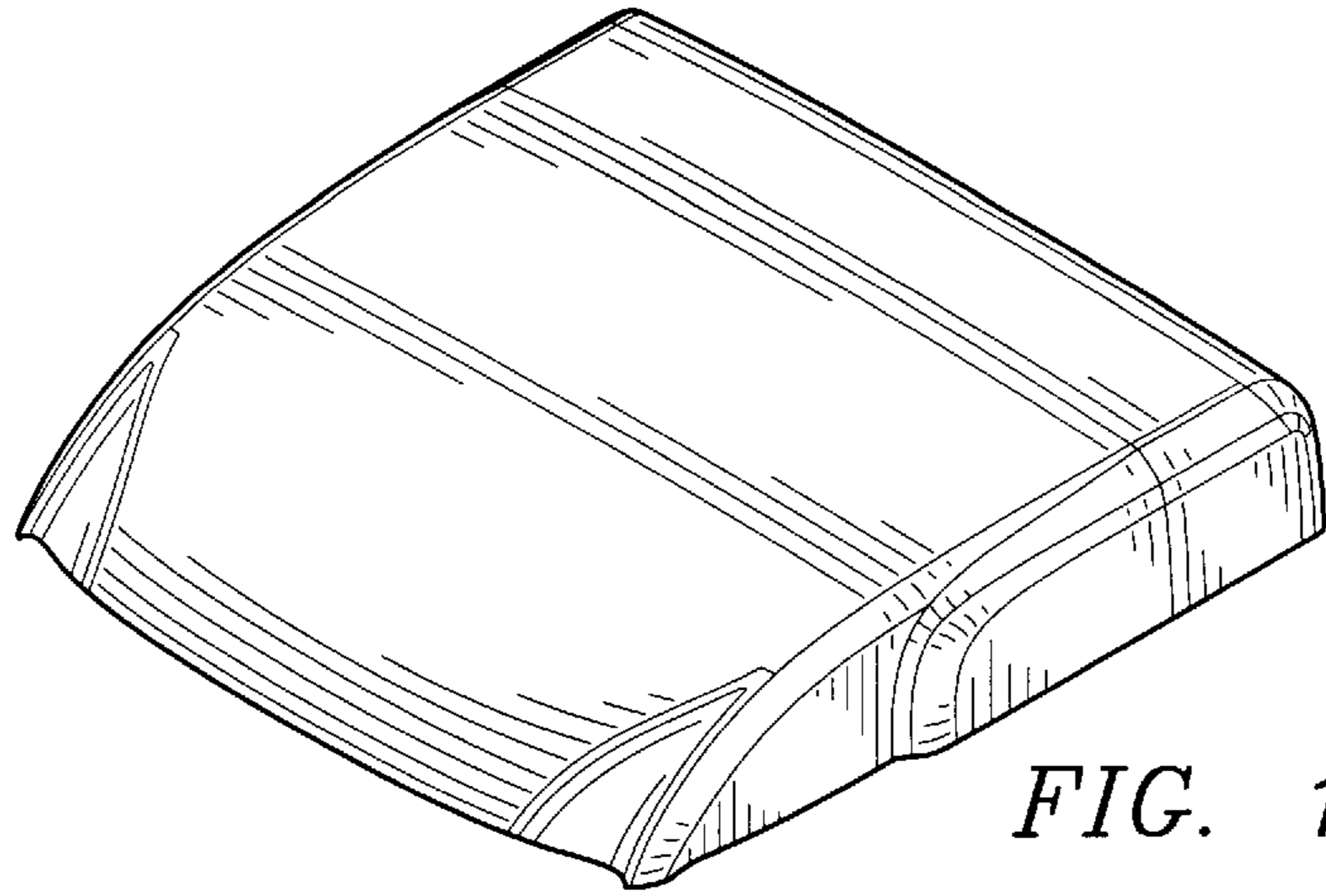

FIG. 1

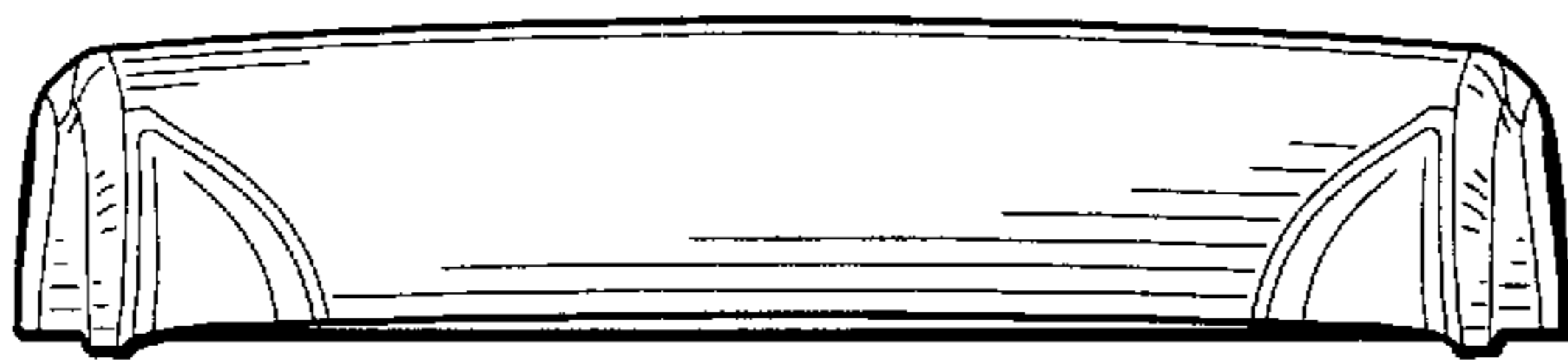

FIG. 2

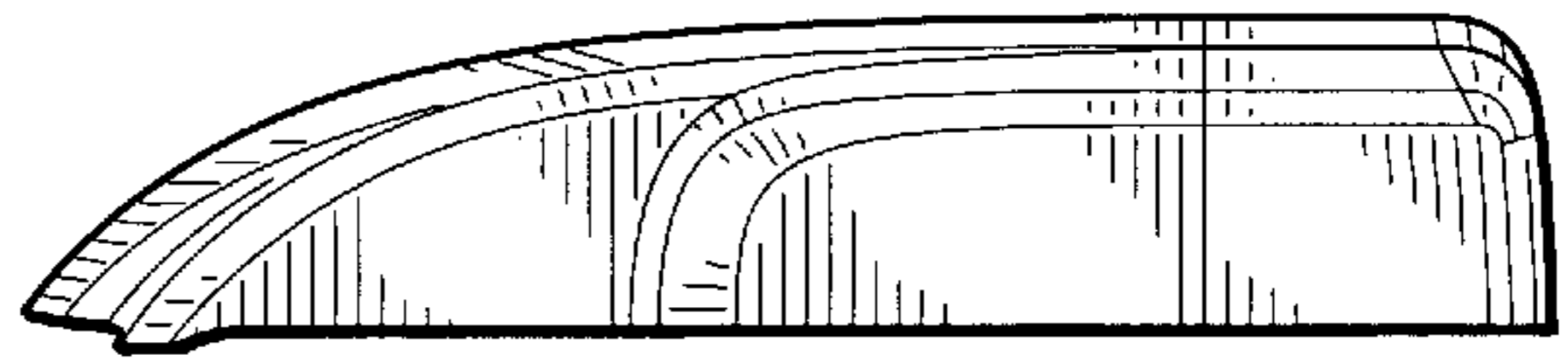

FIG. 3

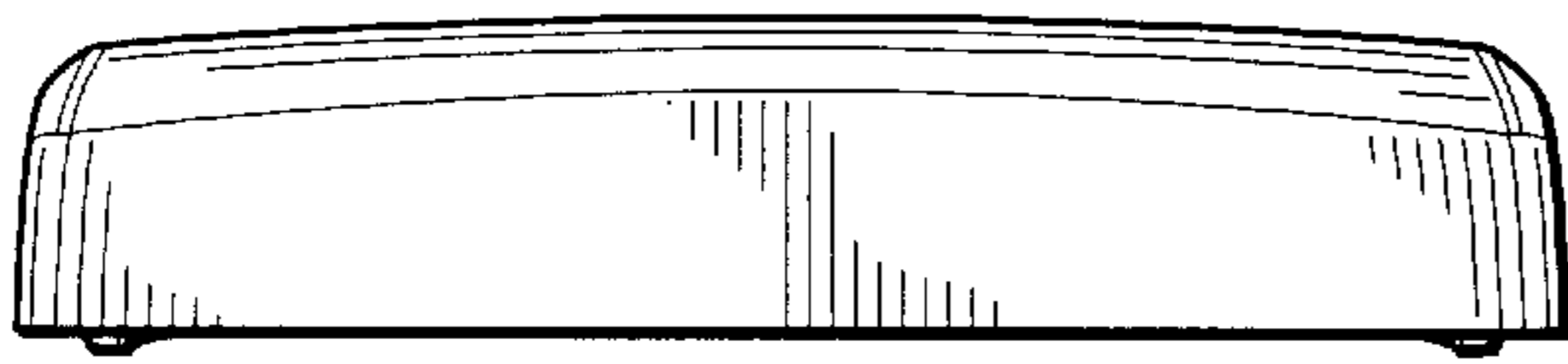

FIG. 4

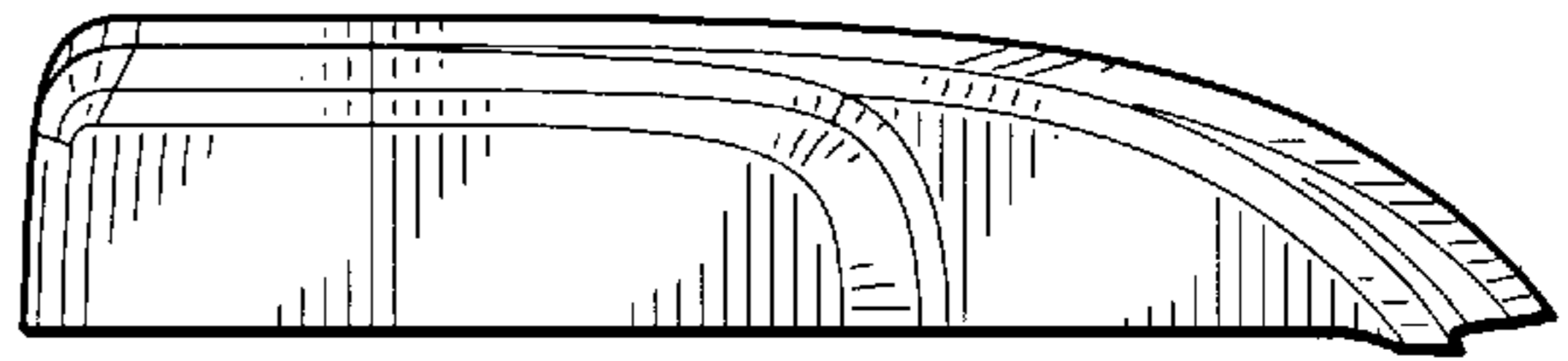

FIG. 5

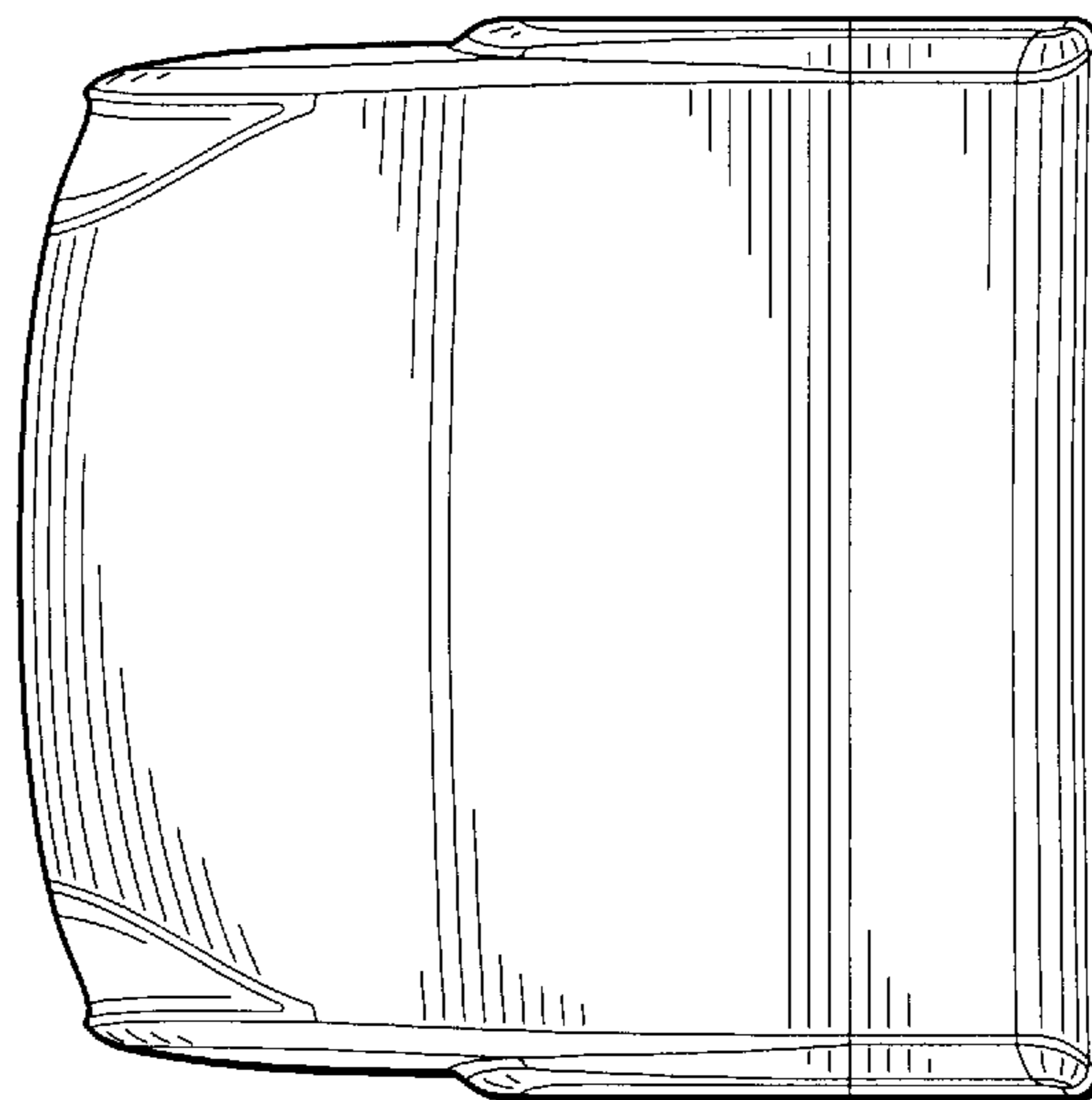

FIG. 6

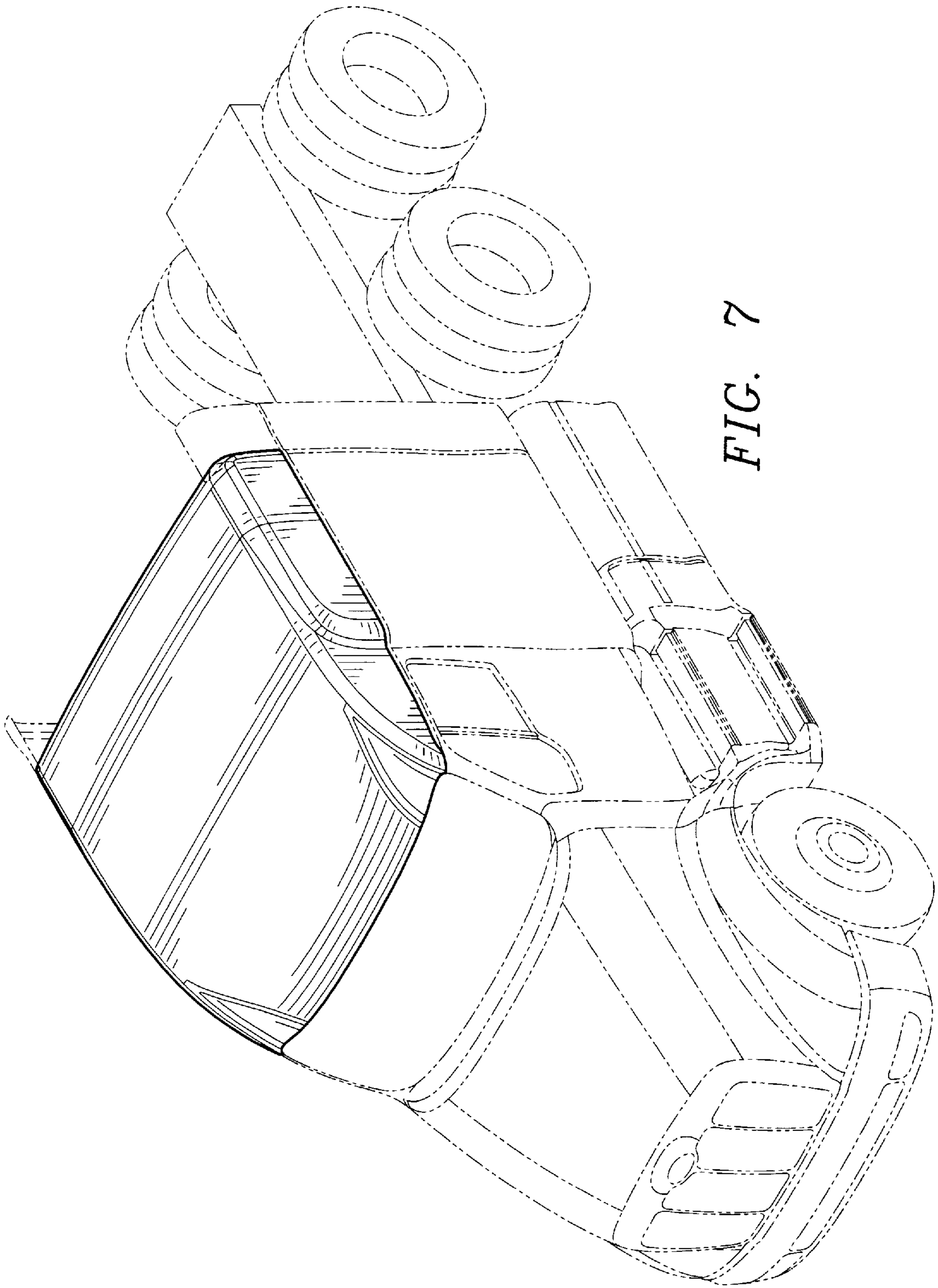

FIG. 7

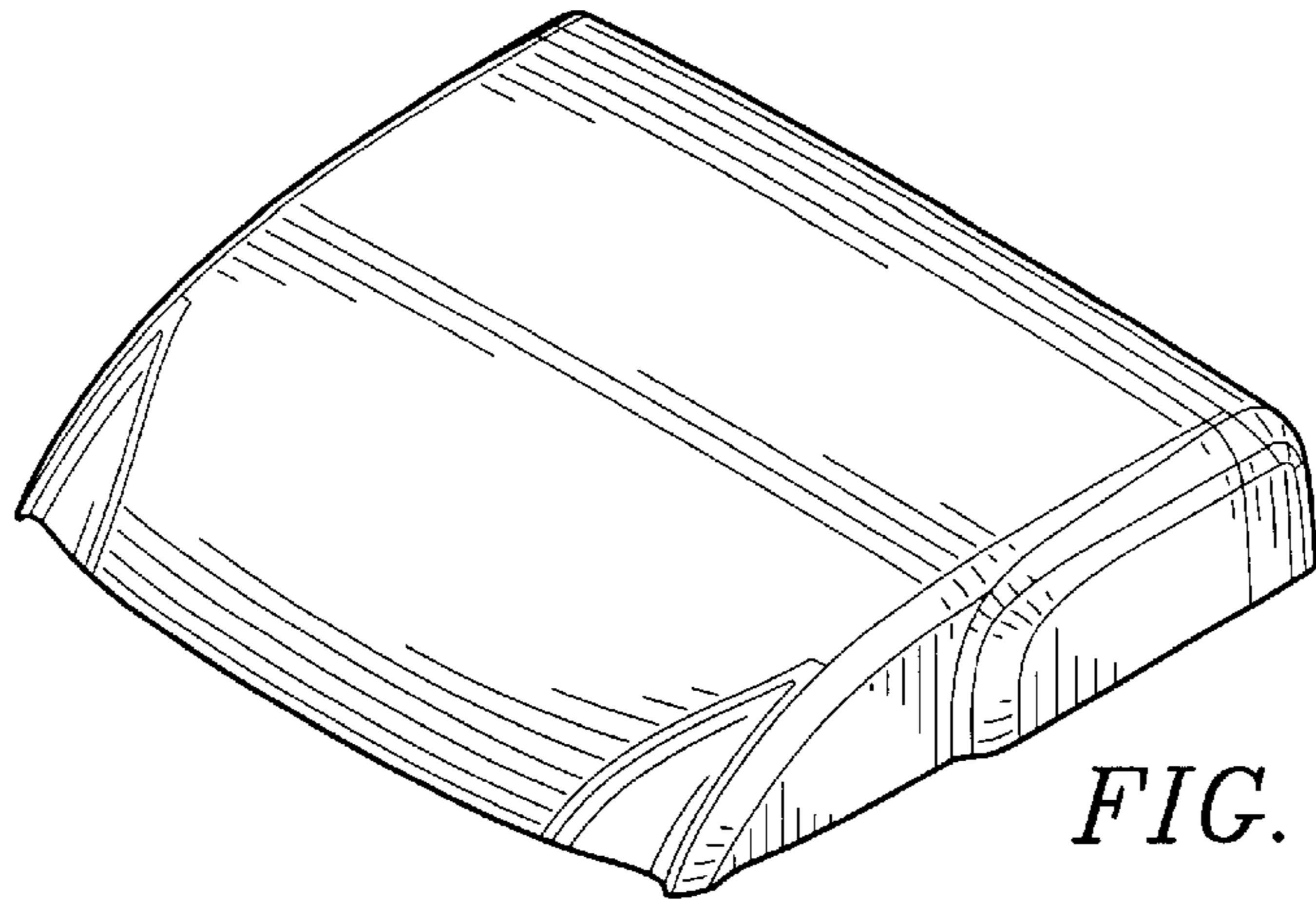

FIG. 8

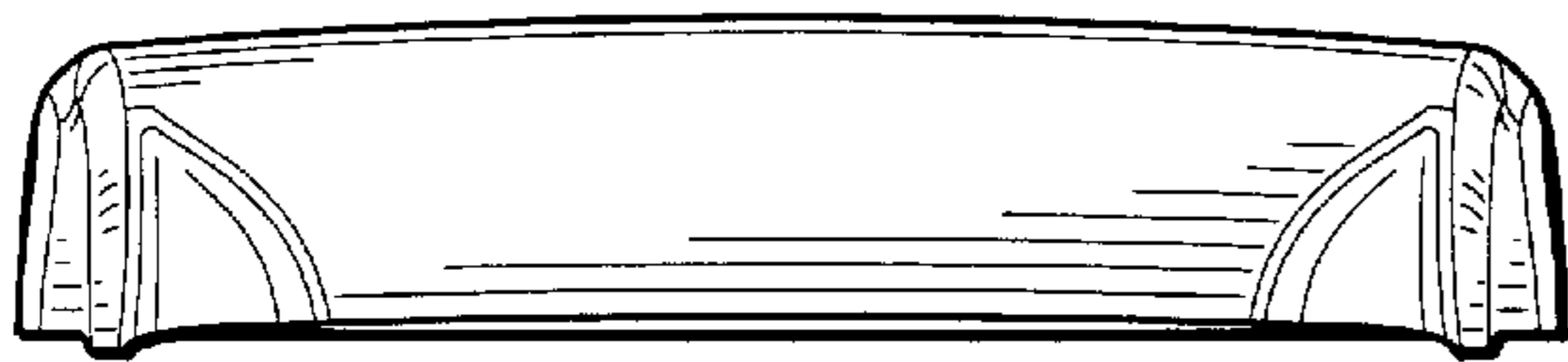

FIG. 9

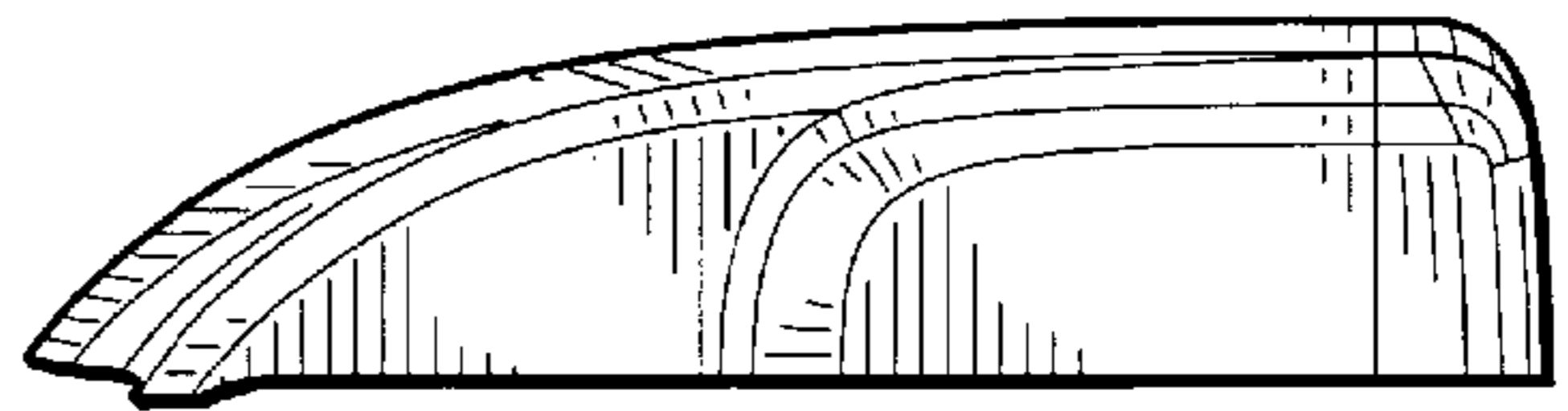

FIG. 10

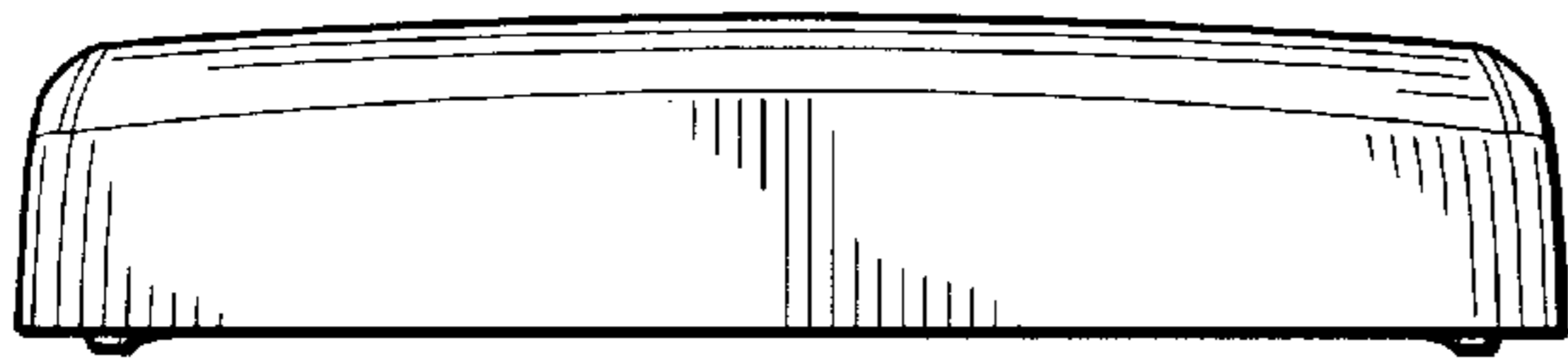

FIG. 11

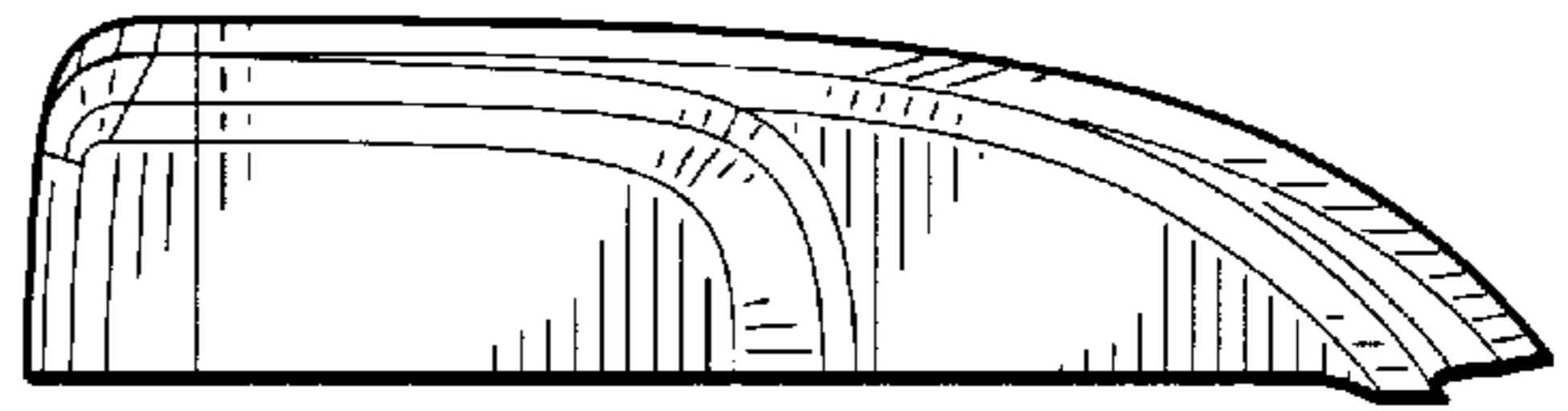

FIG. 12

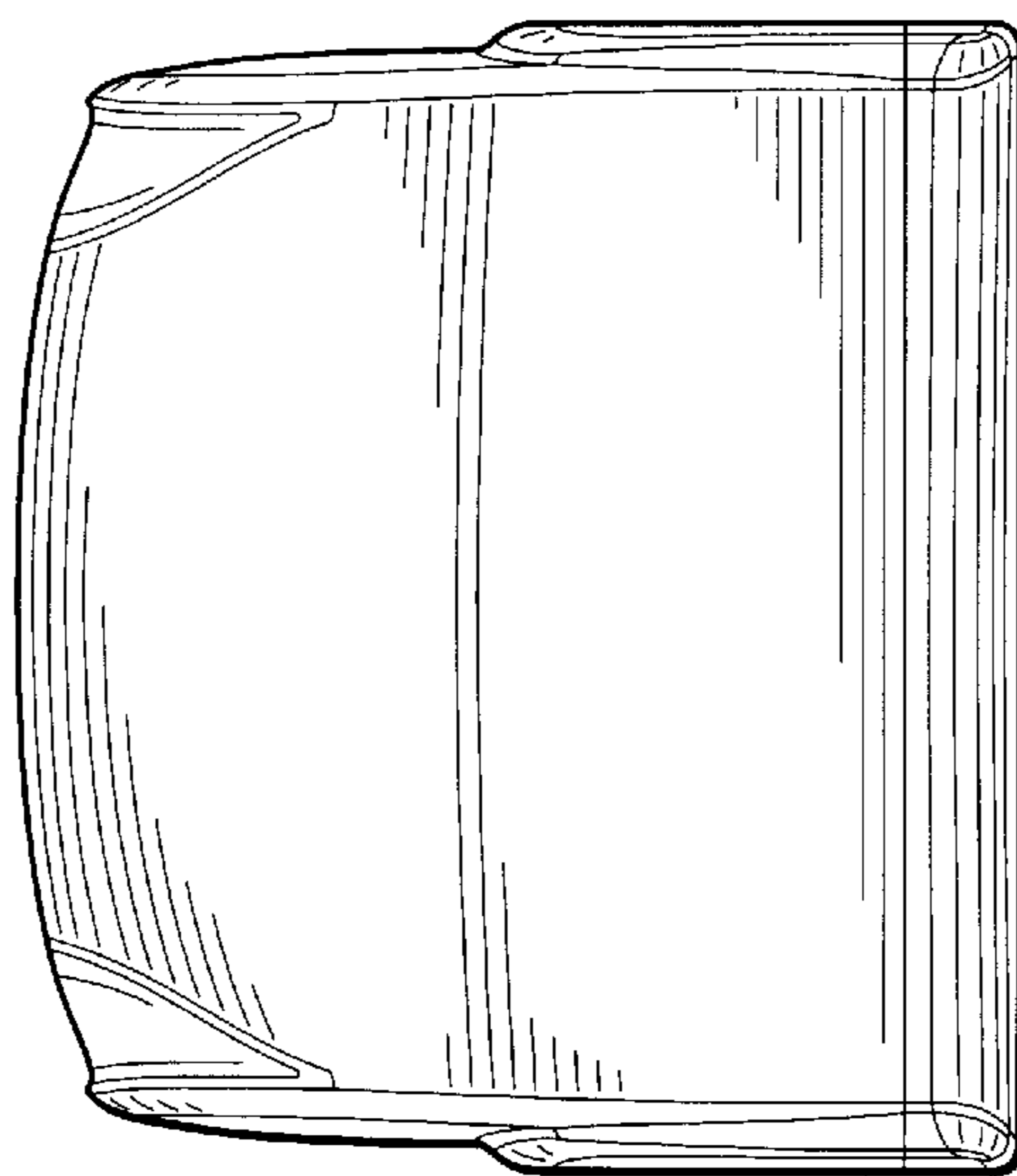

FIG. 13

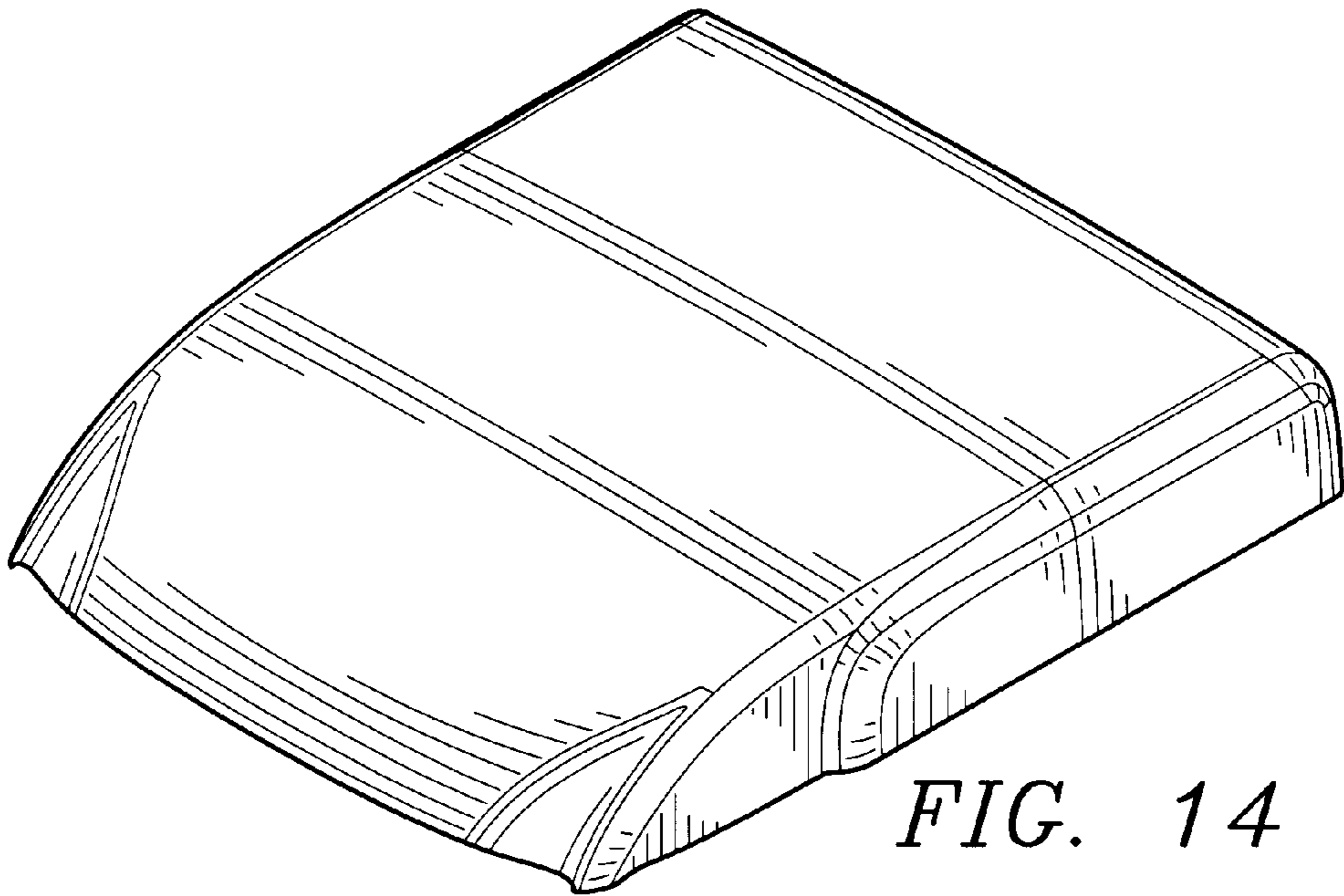

FIG. 14

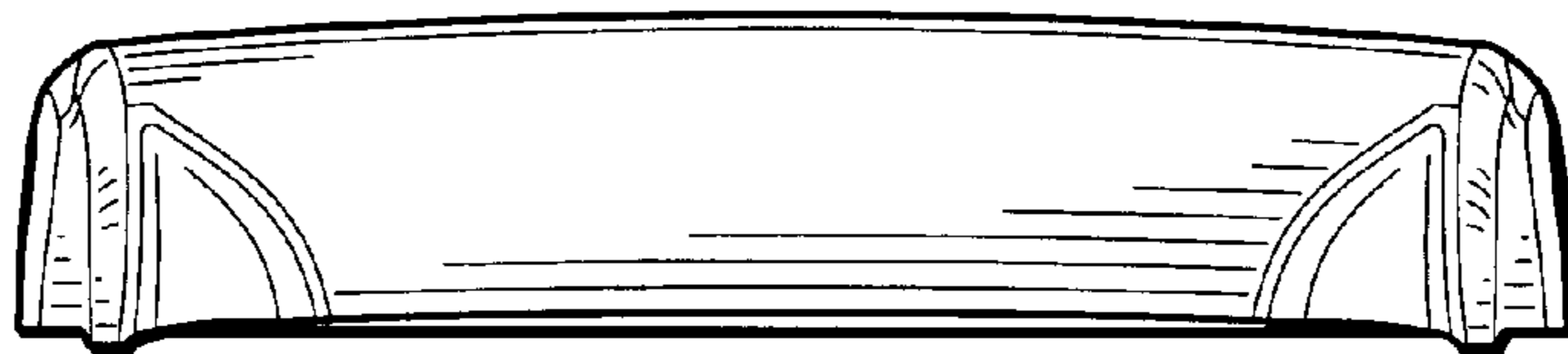

FIG. 15

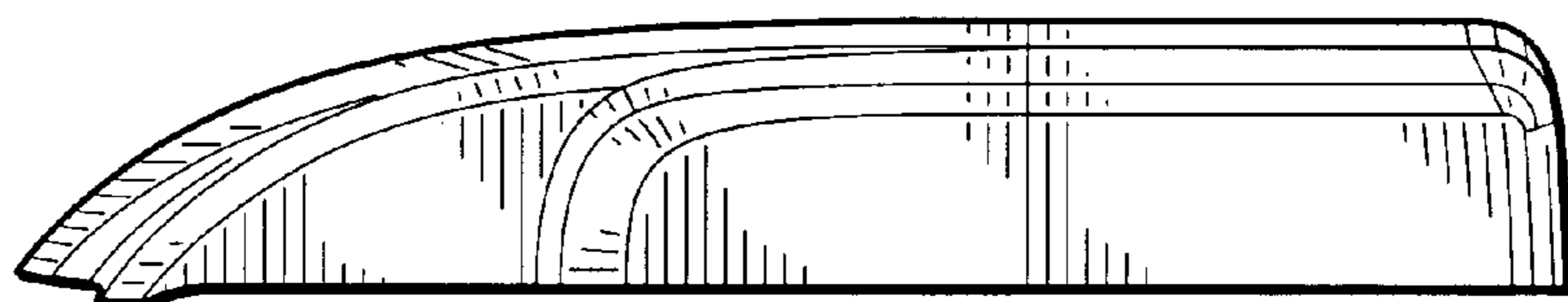

FIG. 16

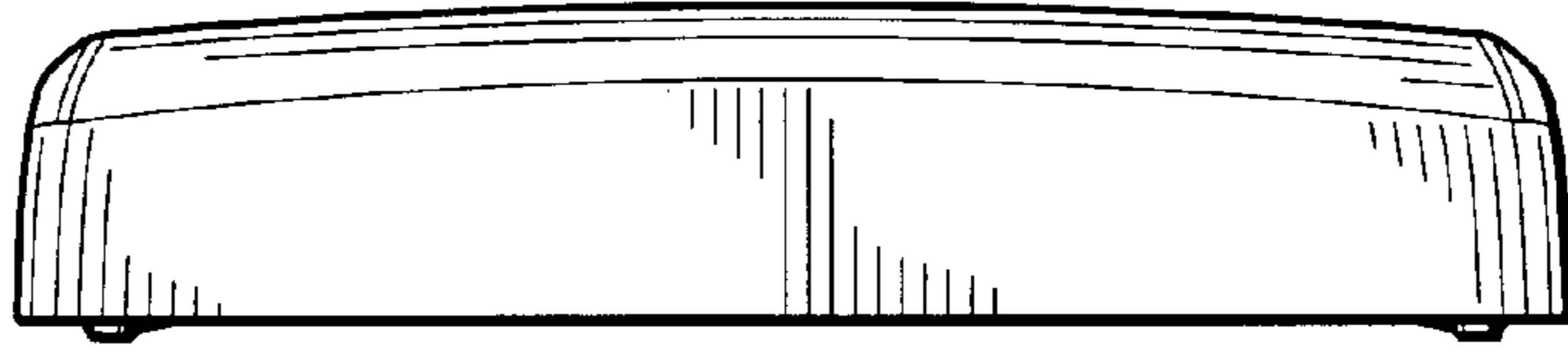

FIG. 17

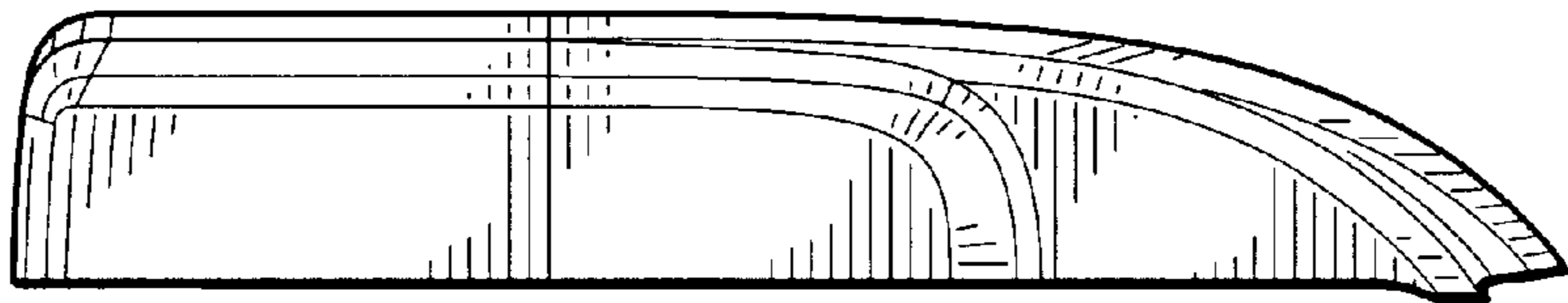

FIG. 18

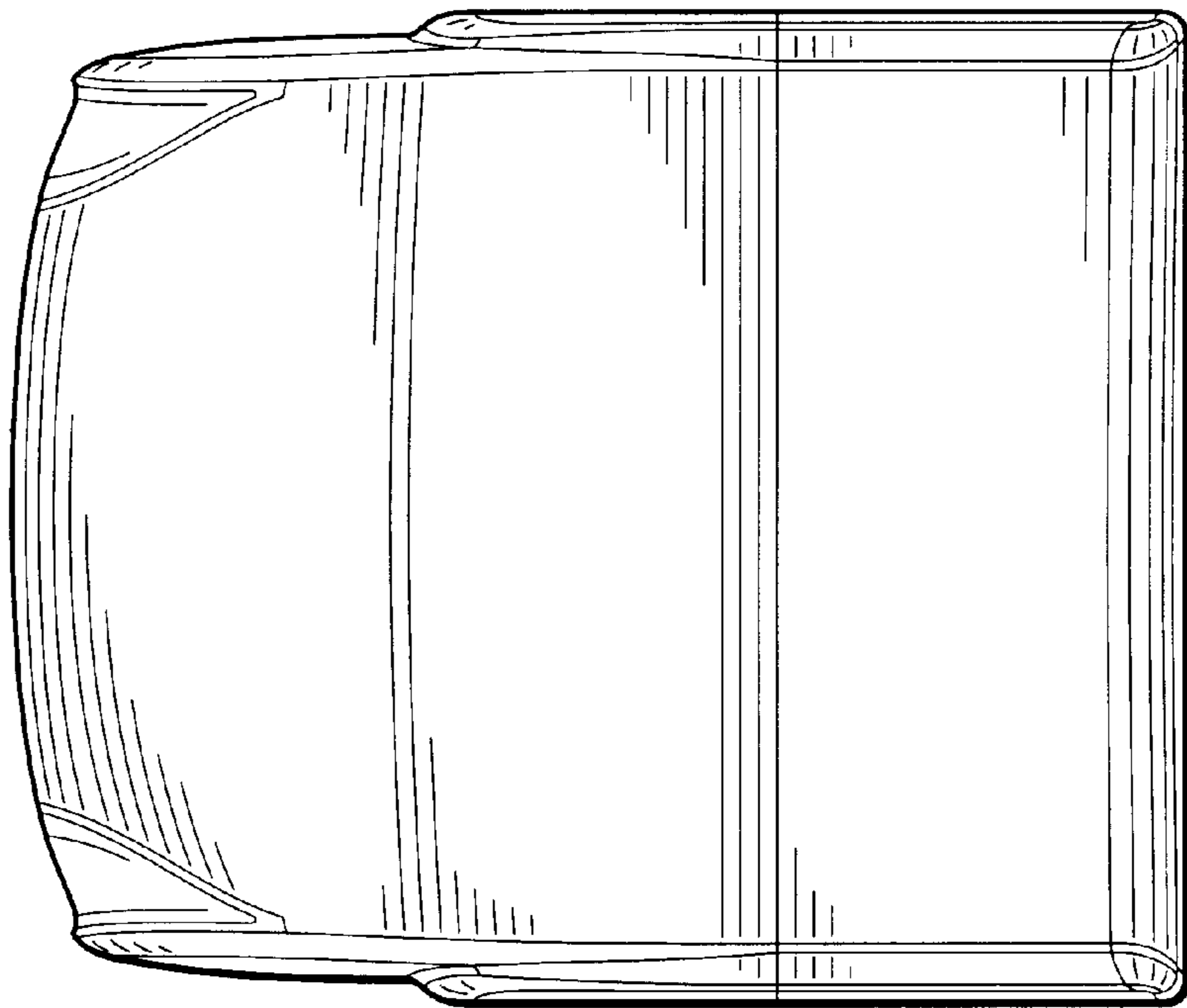

FIG. 19