



US00D434266S

United States Patent [19]

[11] Patent Number: **Des. 434,266**

Dobson et al.

[45] Date of Patent: **** Nov. 28, 2000**

[54] **COOKER**

[75] Inventors: **William C. Dobson; Scott T. Pollnow,**
both of West Bend, Wis.

[73] Assignee: **Premark WB Holdings, Inc.,**
Wilmington, Del.

[**] Term: **14 Years**

[21] Appl. No.: **29/120,985**

[22] Filed: **Mar. 28, 2000**

D. 284,257	6/1986	Greb et al.	D7/355
D. 366,592	1/1996	Cesaroni et al.	D7/360
D. 416,434	11/1999	Pollnow	D7/360
D. 420,246	2/2000	Alonge et al.	D7/360
D. 420,247	2/2000	Kaney et al.	D7/360
D. 425,360	5/2000	Dobson et al.	D7/360

Primary Examiner—Caron D. Veynar
Attorney, Agent, or Firm—Michael Best & Friedrich LLP

Related U.S. Application Data

[63] Continuation of application No. 29/097,446, Dec. 7, 1998,
Pat. No. Des. 425,360.

[51] **LOC (7) Cl.** **07-02**

[52] **U.S. Cl.** **D7/354**

[58] **Field of Search** D7/354–361, 545;
99/324, 325, 340, 347, 403, 410, 411, 413,
419

[57] CLAIM

The ornamental design for a cooker, as shown and described.

DESCRIPTION

FIG. 1 is a perspective view of a cooker constructed in accordance with one preferred embodiment of the invention; FIG. 2 is an elevation view of the front of the cooker shown in FIG. 1;

FIG. 3 is an elevation view of the rear of the cooker shown in FIGS. 1 and 2;

FIG. 4 is an elevation view of the right of the cooker shown in FIGS. 1, 2 and 3;

FIG. 5 is an elevation view of the left of the cooker shown in FIGS. 1, 2, 3 and 4;

FIG. 6 is a top plan view of the cooker shown in FIGS. 1, 2, 3, 4 and 5; and,

FIG. 7 is a bottom plan view of the cooker shown in FIGS. 1, 2, 3, 4, 5 and 6.

The broken line showings in FIGS. 1–7 are for illustrative purposes only and form no part of the claimed design.

[56] References Cited

U.S. PATENT DOCUMENTS

D. 153,894	5/1949	Mortrude	D7/354
D. 199,747	12/1964	Farber	D7/354
D. 248,363	7/1978	Rinaldi	D7/354
D. 253,574	12/1979	Anderson, Jr.	D7/356
D. 254,355	3/1980	Ottier	D7/545
D. 275,925	10/1984	Bowen et al.	D7/357

1 Claim, 7 Drawing Sheets

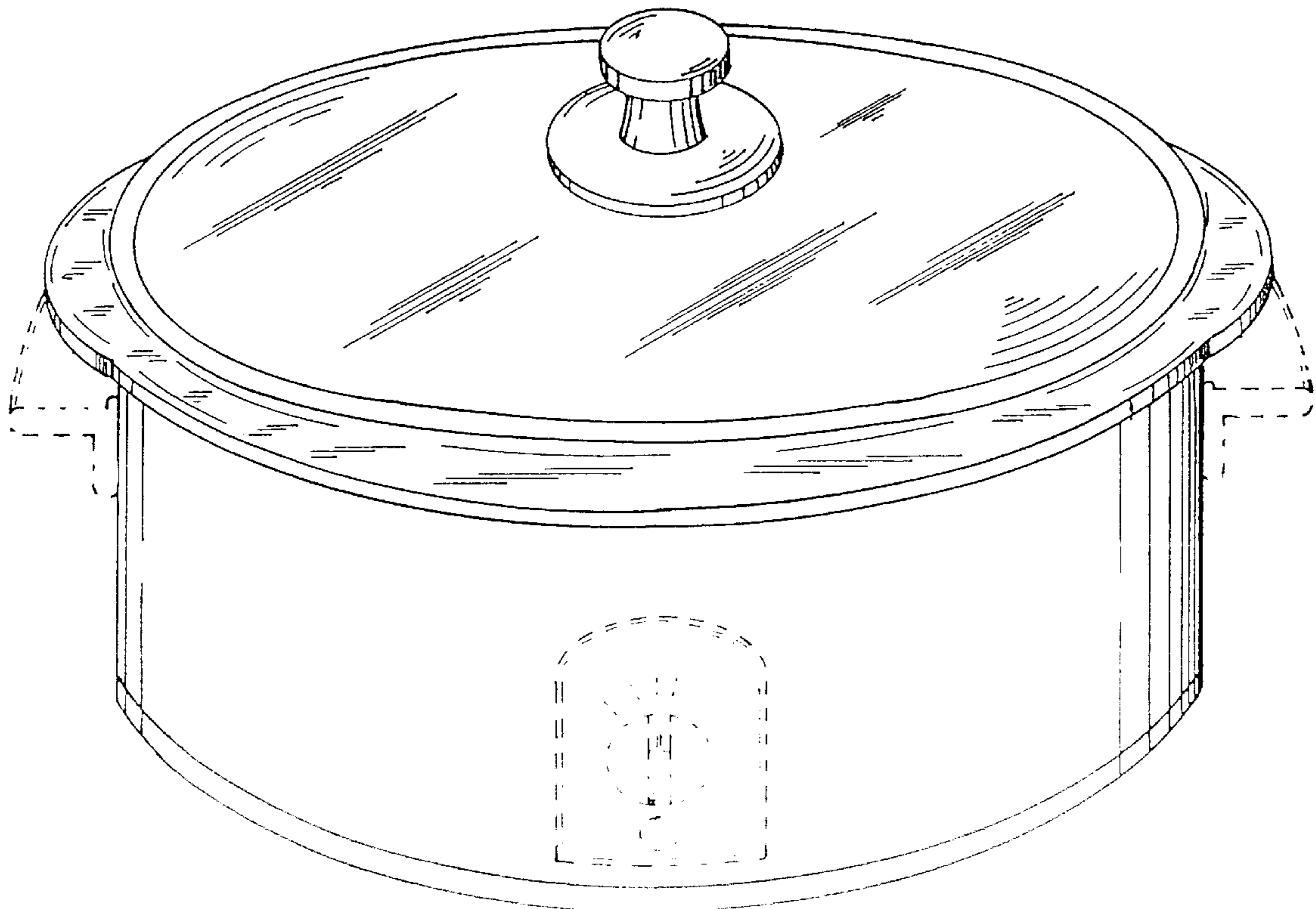

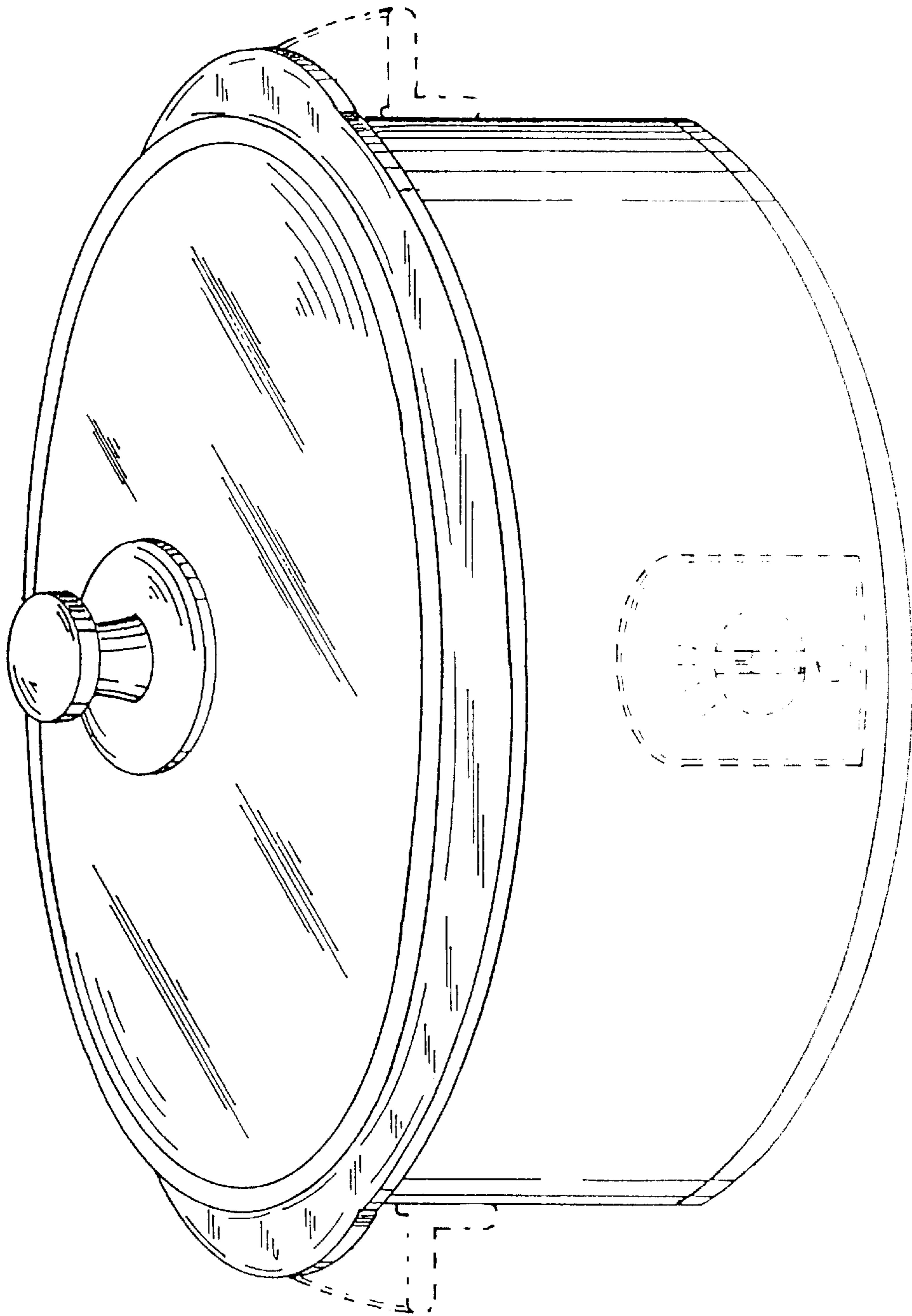

Fig. 1

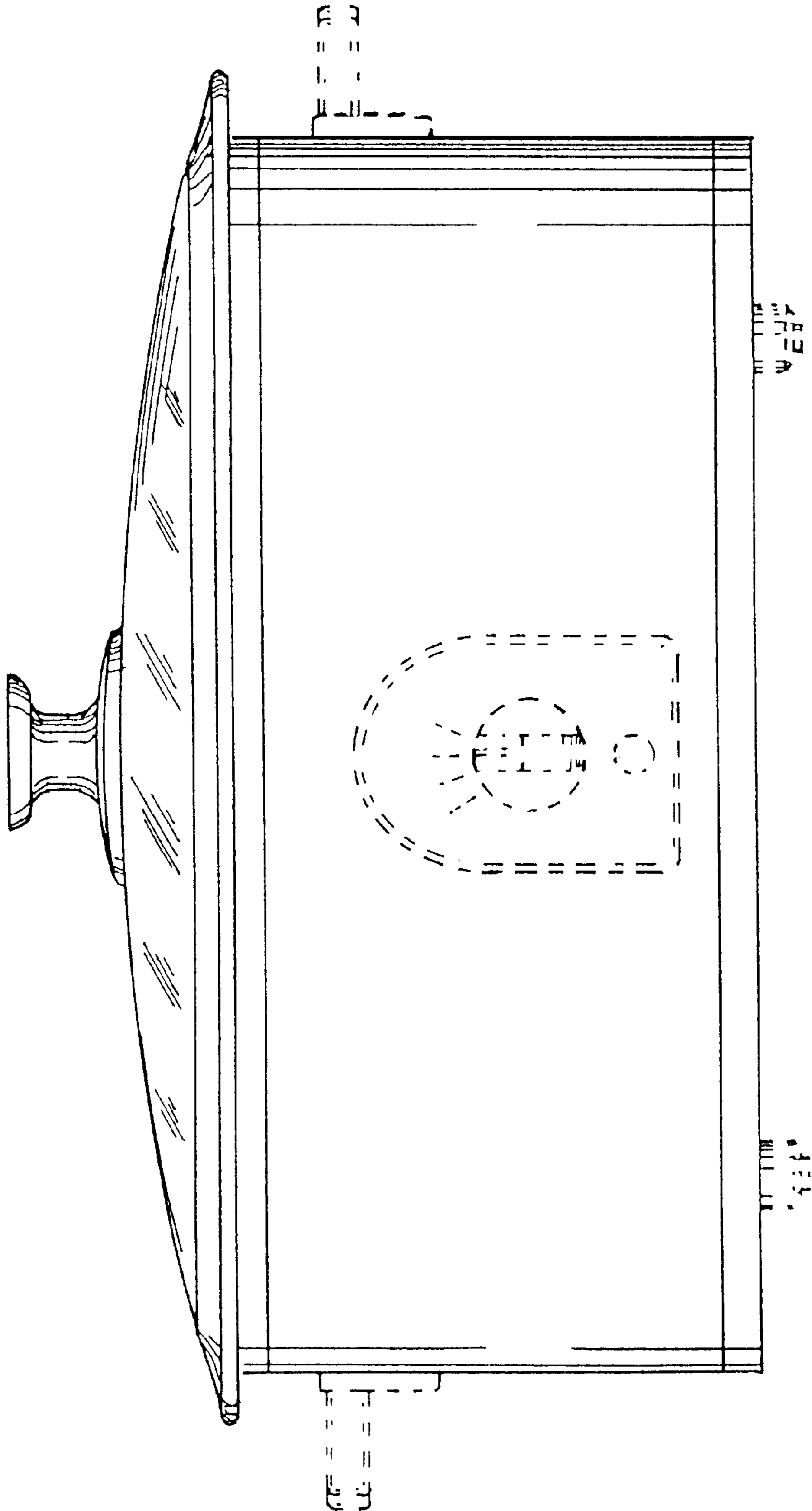

Fig. 2

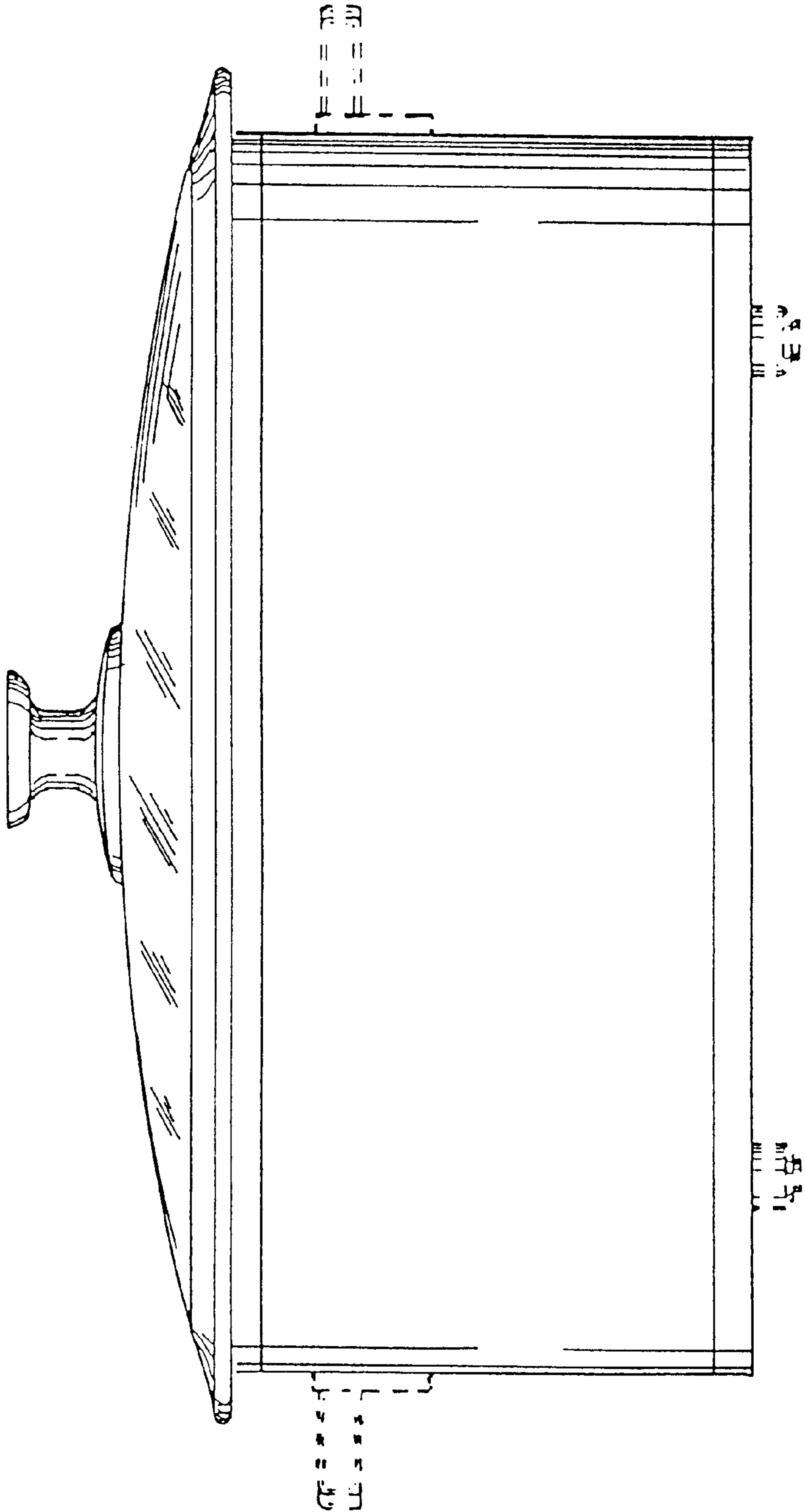

Fig. 3

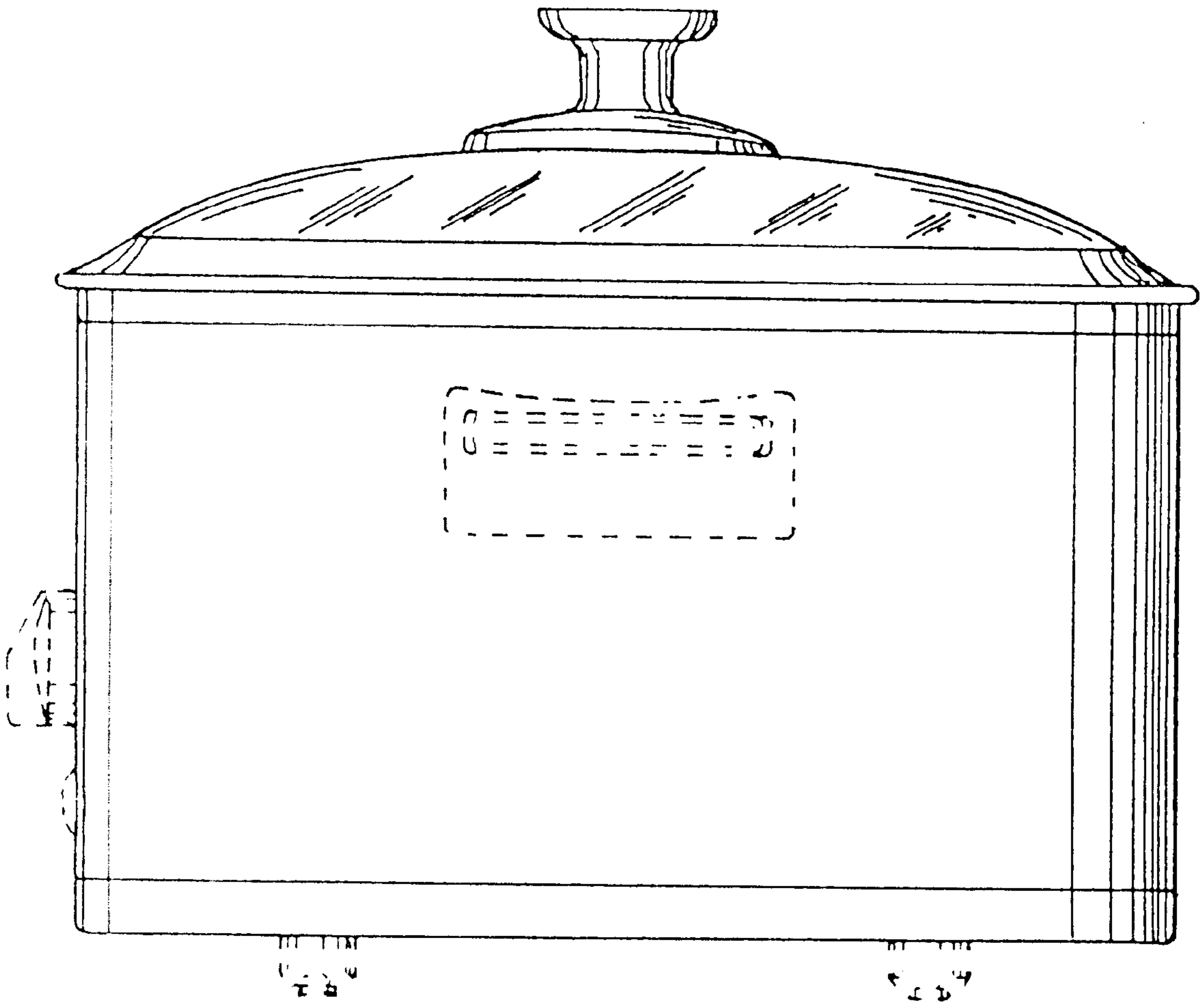

Fig. 4

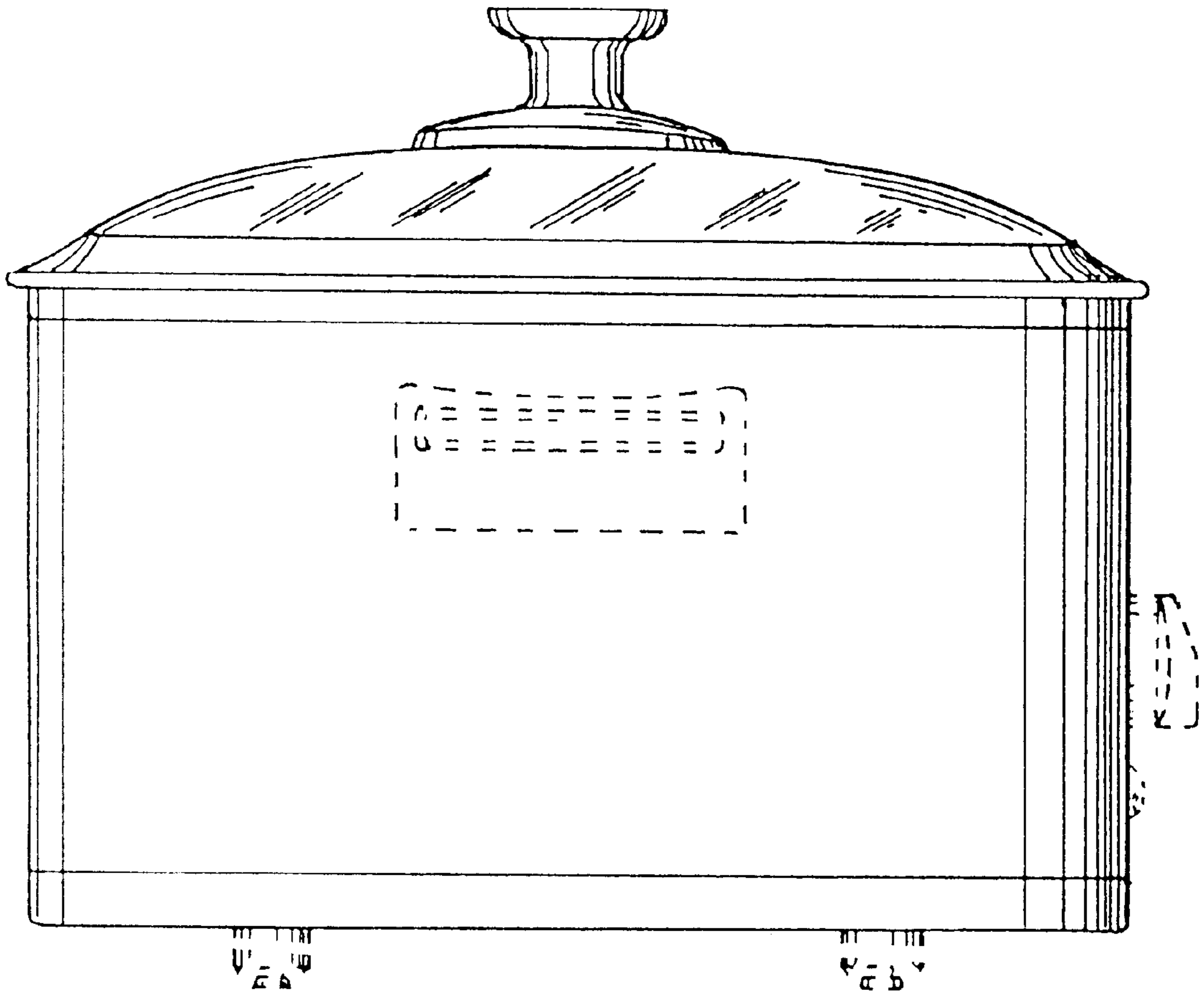

Fig. 5

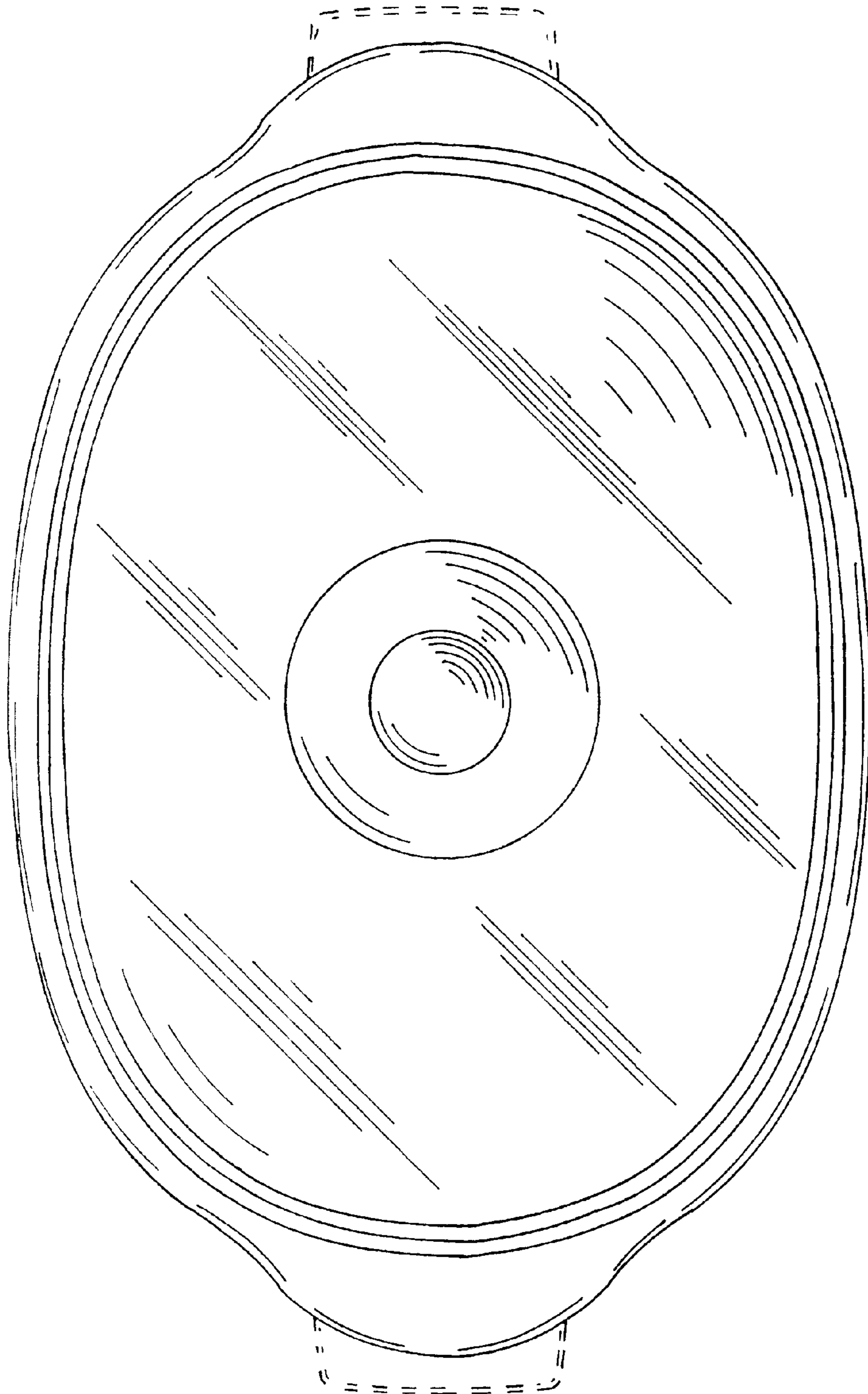

Fig. 6

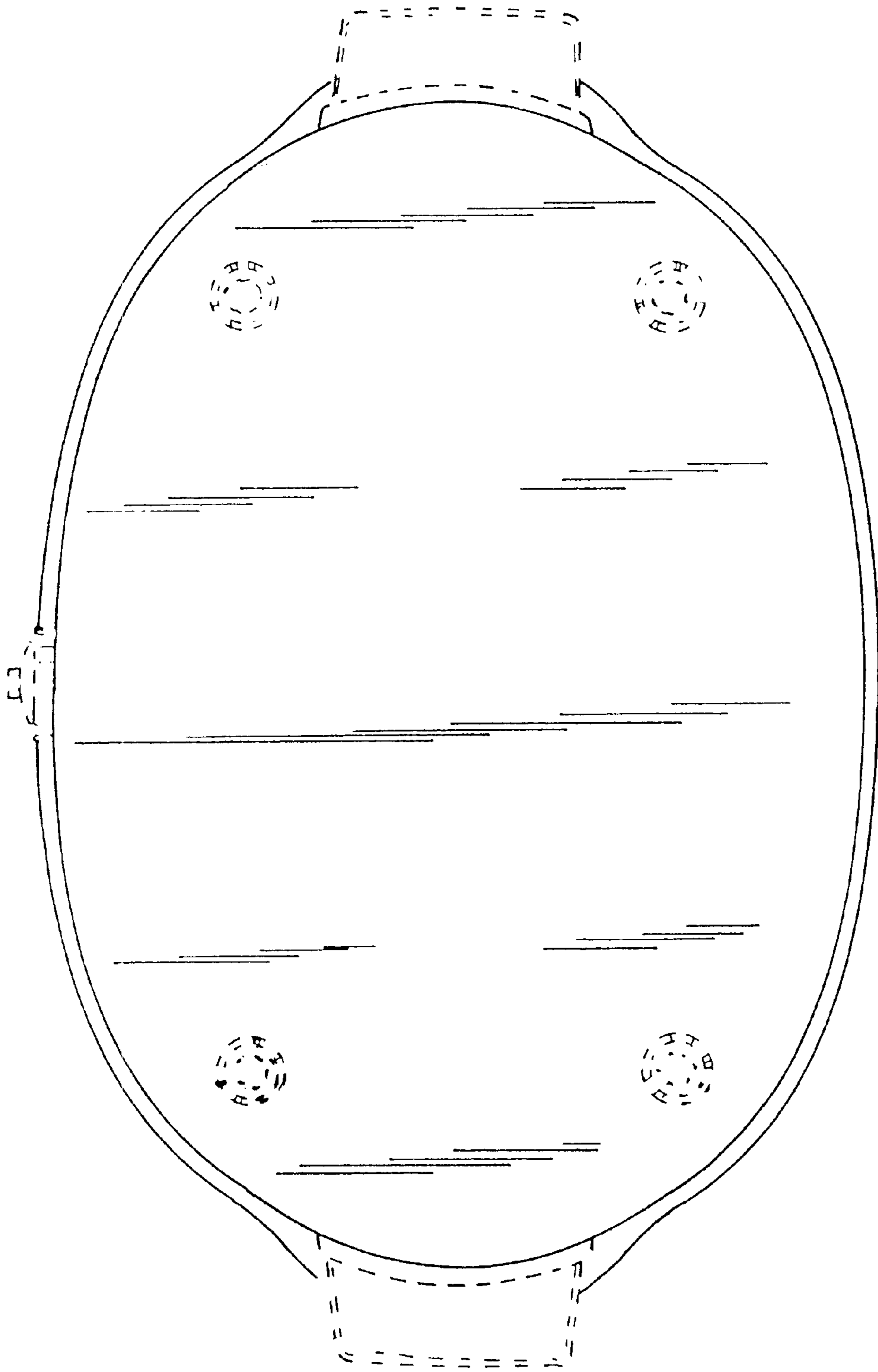

Fig. 7