



US00D434224S

United States Patent [19]
Tiramani et al.

[11] **Patent Number: Des. 434,224**

[45] **Date of Patent: ** Nov. 28, 2000**

[54] **LUGGAGE ARTICLE**

[75] Inventors: **Paolo M. B. Tiramani; John A. Bozak**, both of Greenwich; **Soohyun Ham**, Stamford, all of Conn.

[73] Assignee: **500 Group, Inc.**, Greenwich, Conn.

[**] Term: **14 Years**

[21] Appl. No.: **29/118,008**

[22] Filed: **Feb. 2, 2000**

[51] **LOC (7) Cl.** **03-01**

[52] **U.S. Cl.** **D3/279; D3/282; D3/276**

[58] **Field of Search** **D3/272, 273, 276, D3/279, 282, 294; 190/18 A, 110, 111-115**

[56] **References Cited**

U.S. PATENT DOCUMENTS

- D. 261,671 11/1981 Livesey D3/282
- D. 351,726 10/1994 Lin D3/276
- D. 354,396 1/1995 Lowenstein D3/279

- D. 364,504 11/1995 Bieber D3/279
- D. 428,698 8/2000 Cheng D3/276
- 5,116,289 5/1992 Pond 190/18 A
- 5,755,311 5/1998 Younessian et al. .

Primary Examiner—Raphael Barkai
Attorney, Agent, or Firm—David V. Radack; Eckert Seamans Cherin & Mellott, LLC

[57] **CLAIM**

The ornamental design for a luggage article, as shown and described.

DESCRIPTION

FIG. 1 is a front perspective view of a luggage article showing our design;
FIG. 2 is a top plan view thereof;
FIG. 3 is a bottom plan view thereof;
FIG. 4 is a front elevational plan view thereof;
FIG. 5 is a back elevational plan view thereof;
FIG. 6 is a left side elevational plan view thereof; and,
FIG. 7 is a right side elevational view thereof.

1 Claim, 4 Drawing Sheets

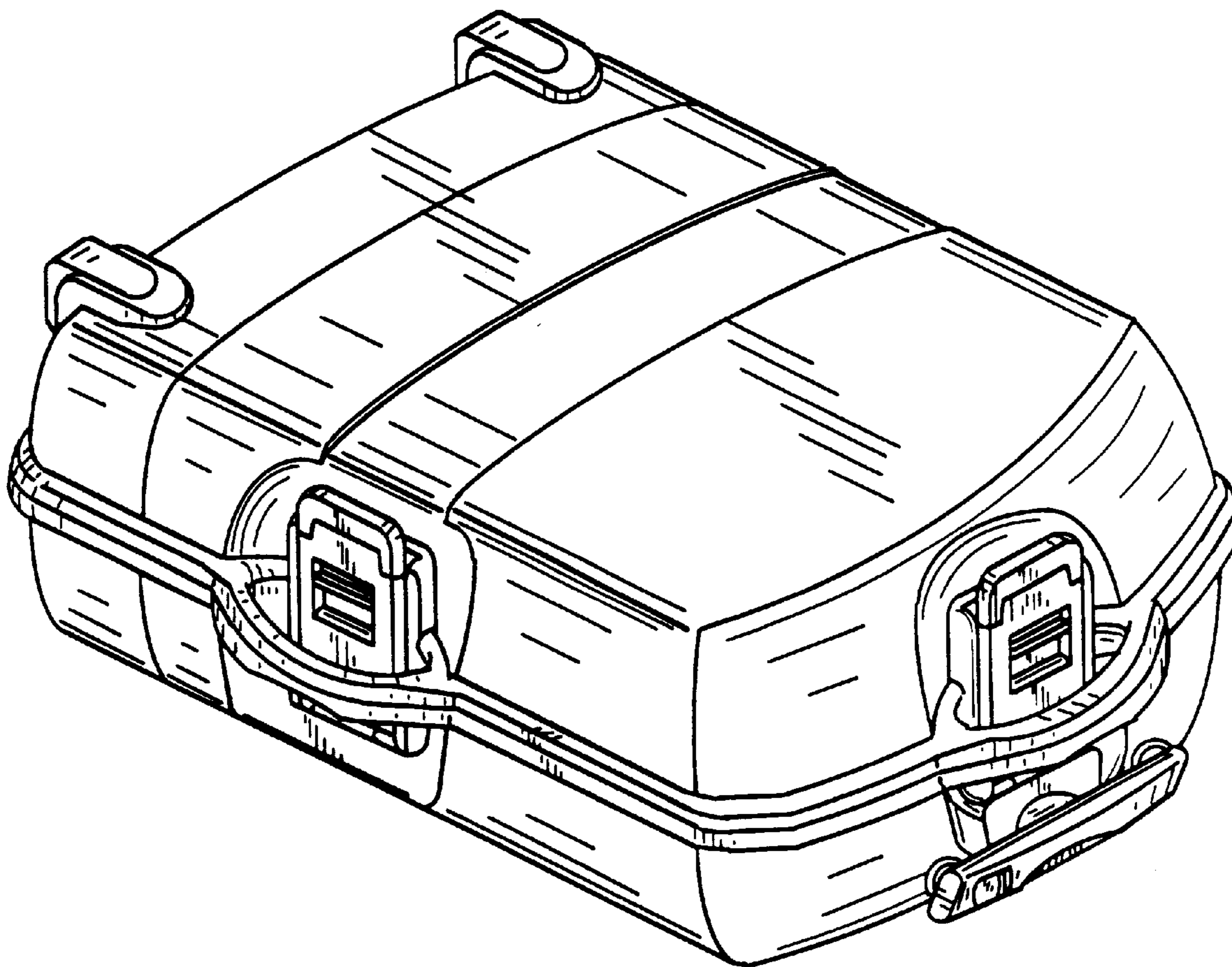

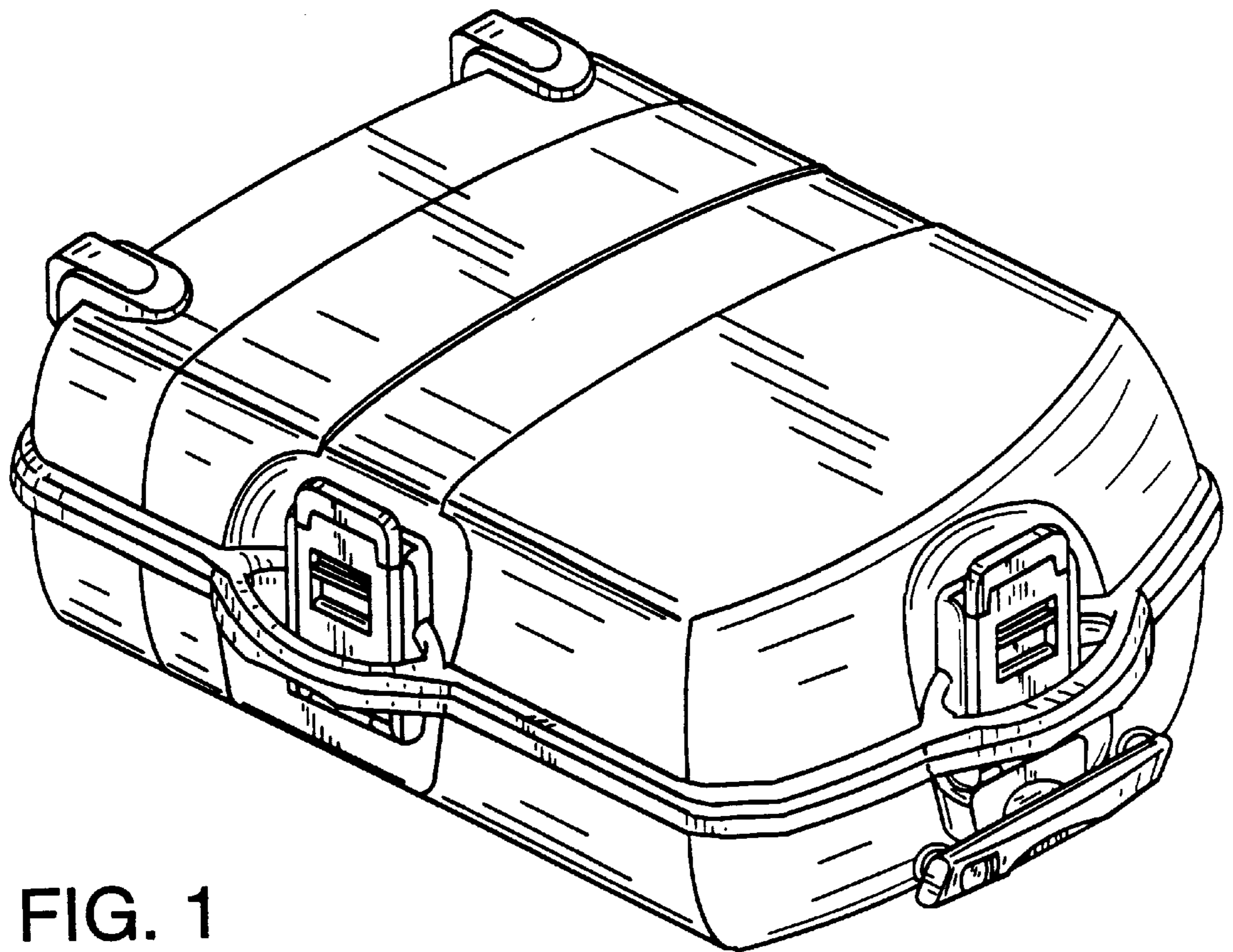

FIG. 1

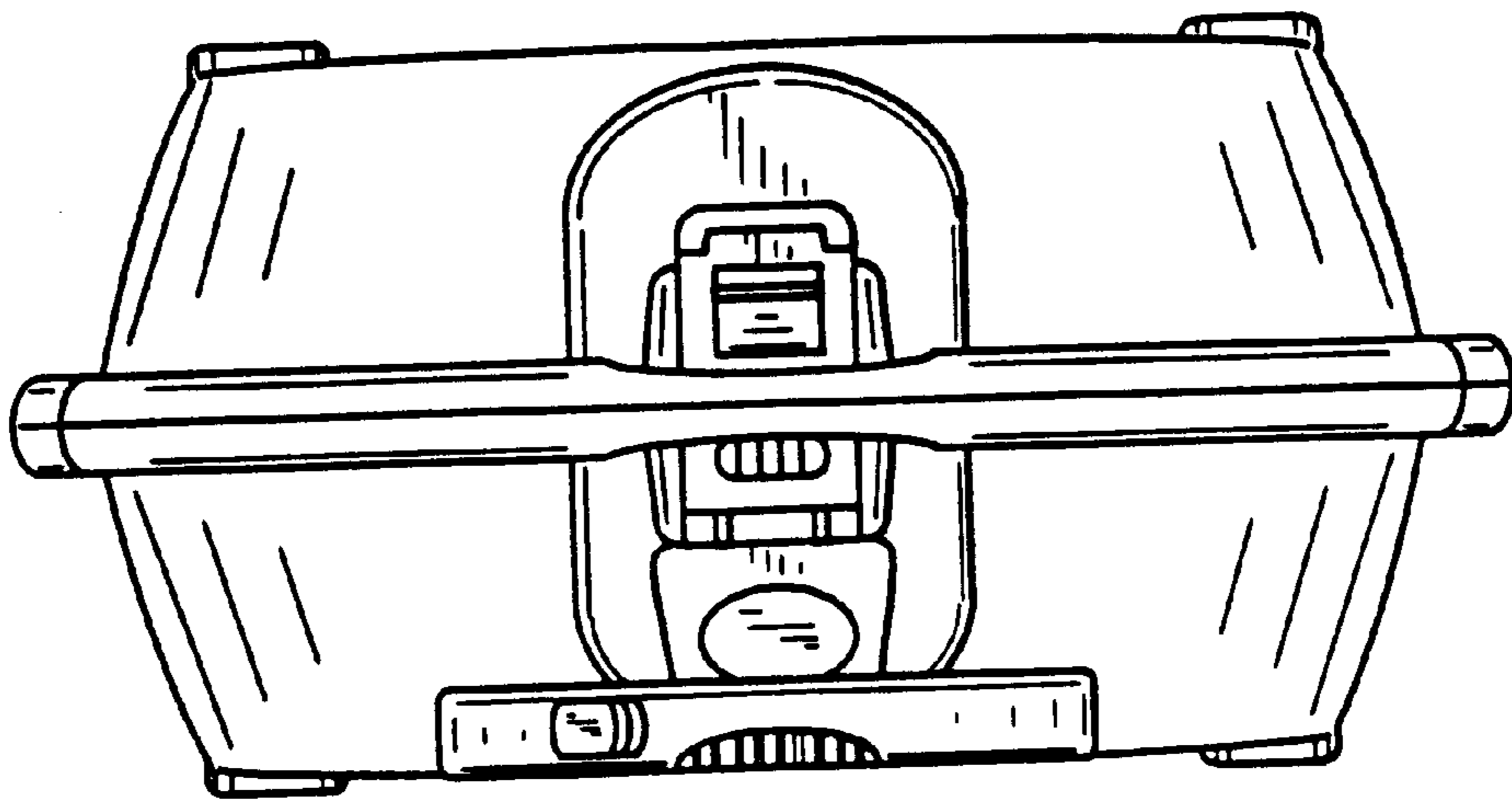

FIG. 2

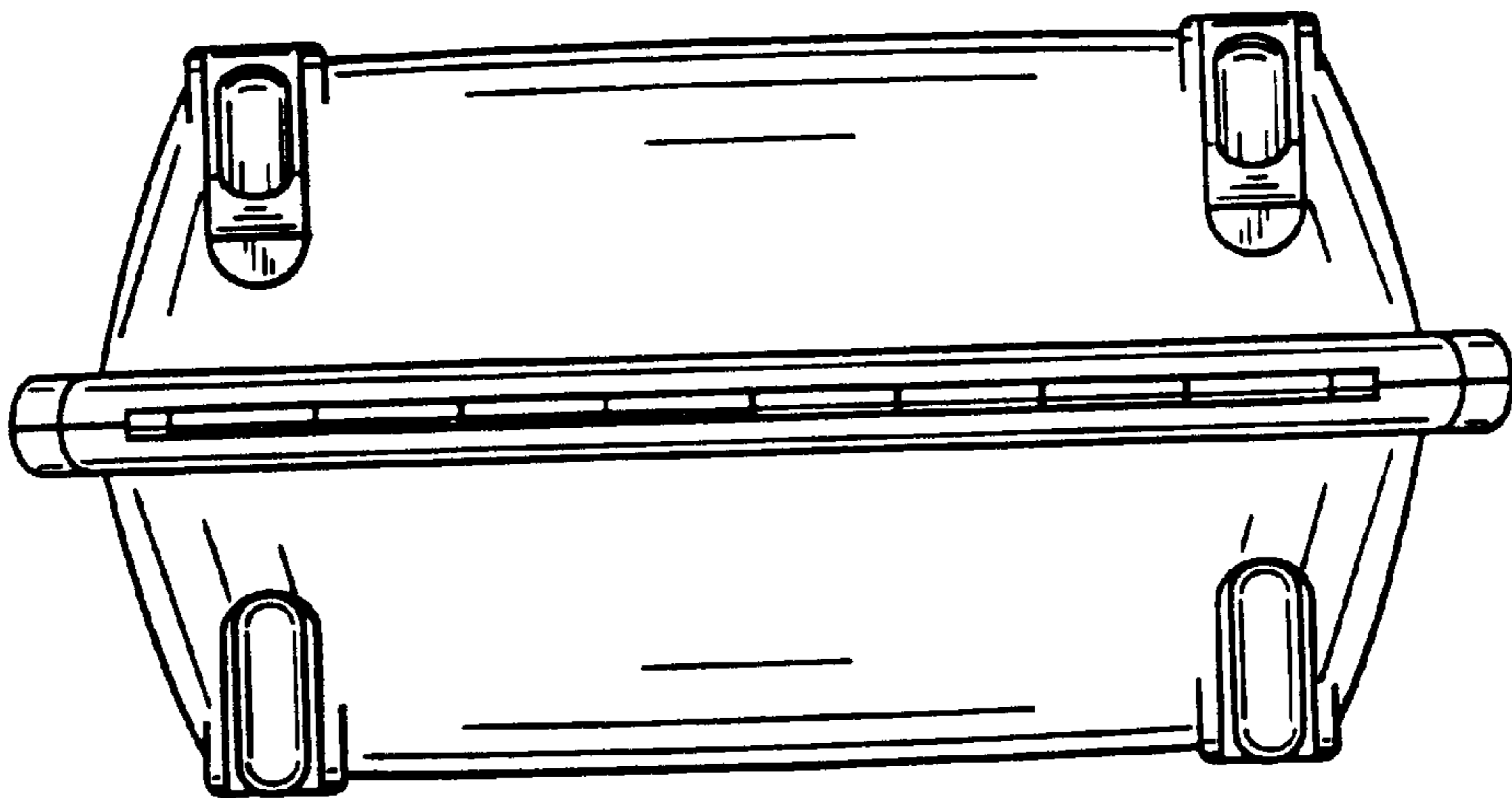

FIG. 3

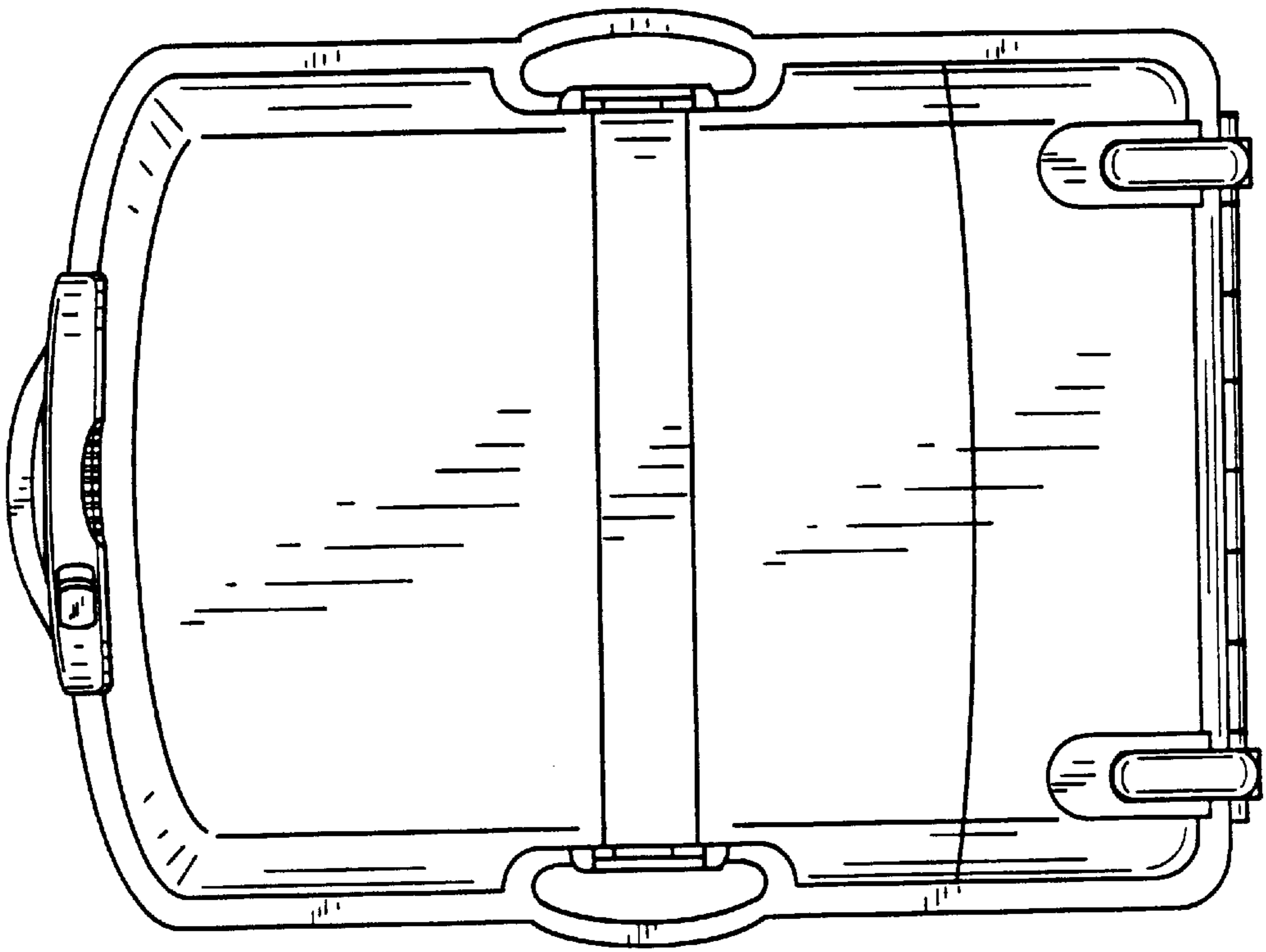

FIG. 5

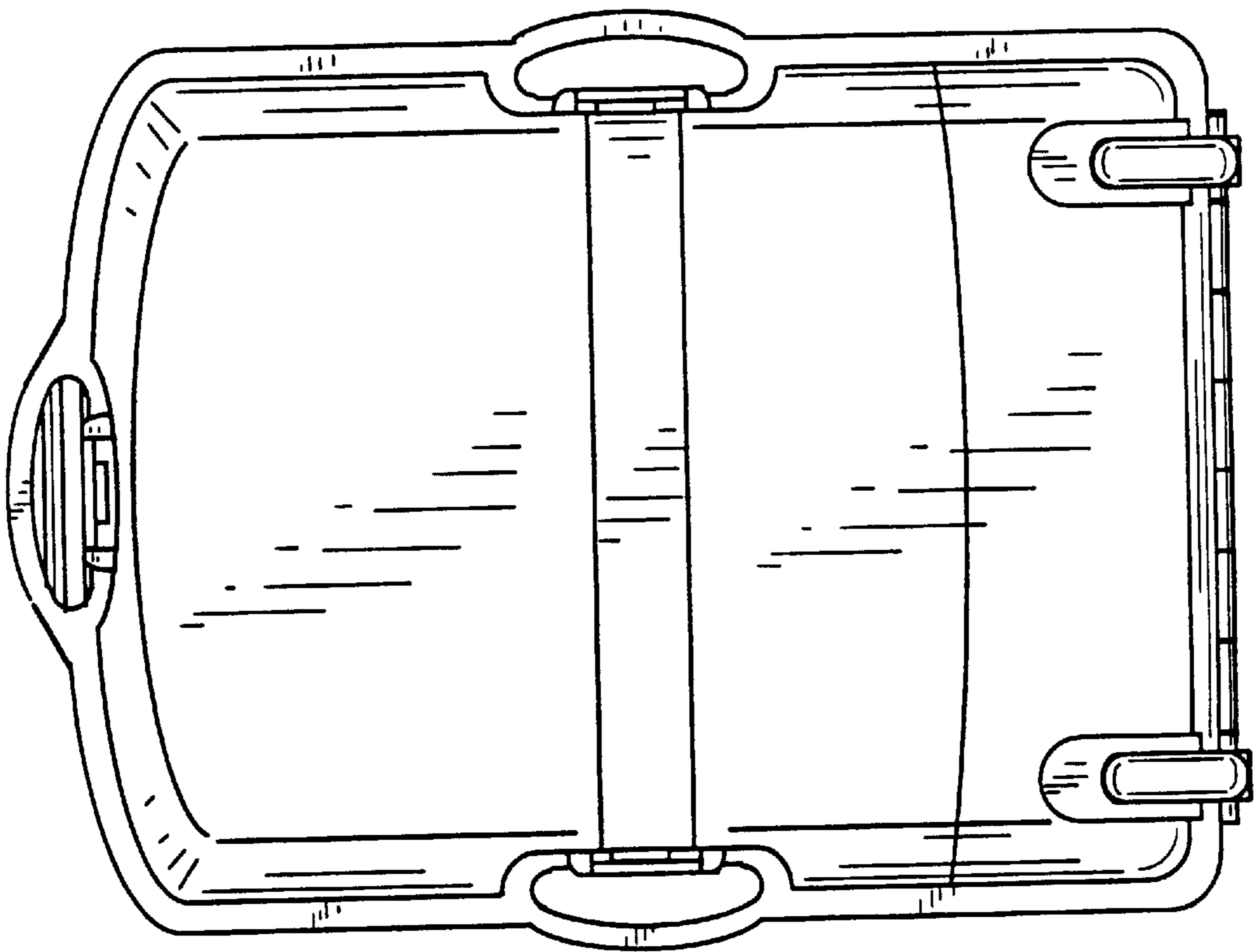

FIG. 4

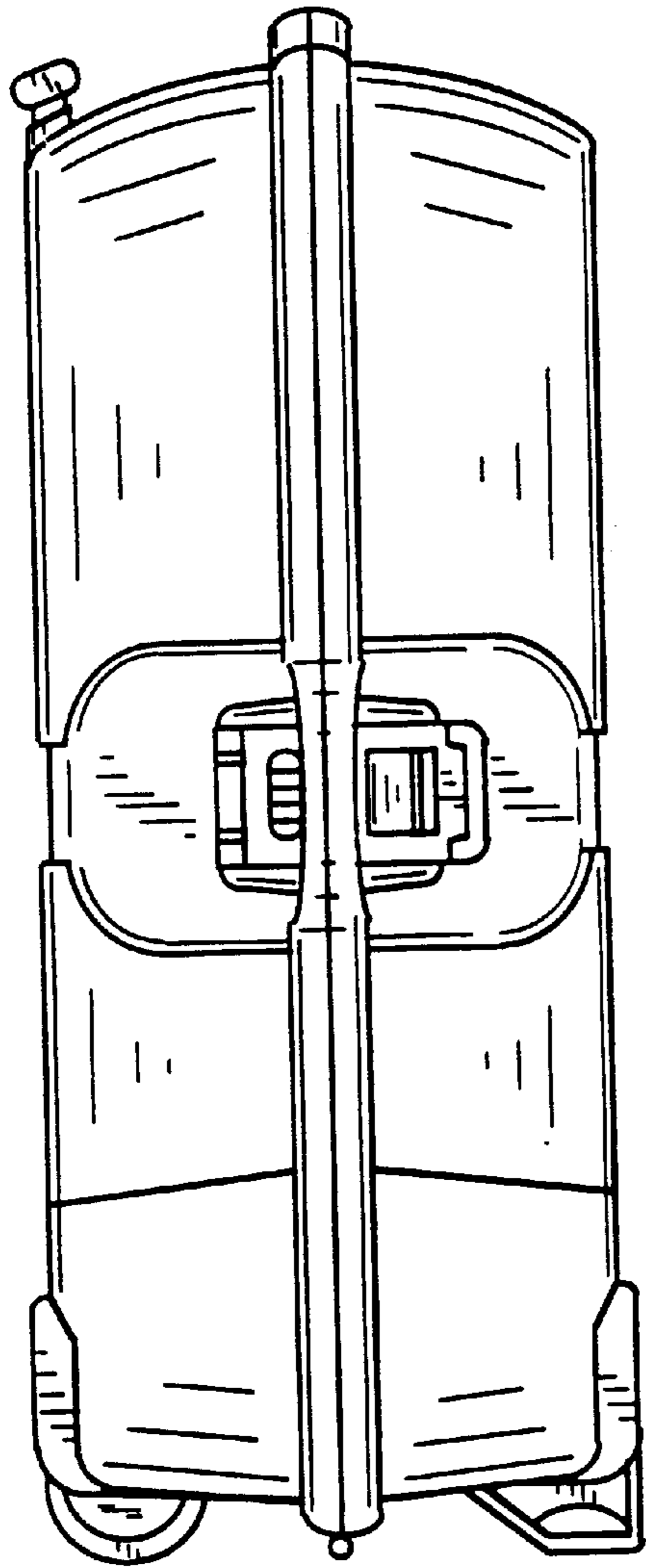

FIG. 6

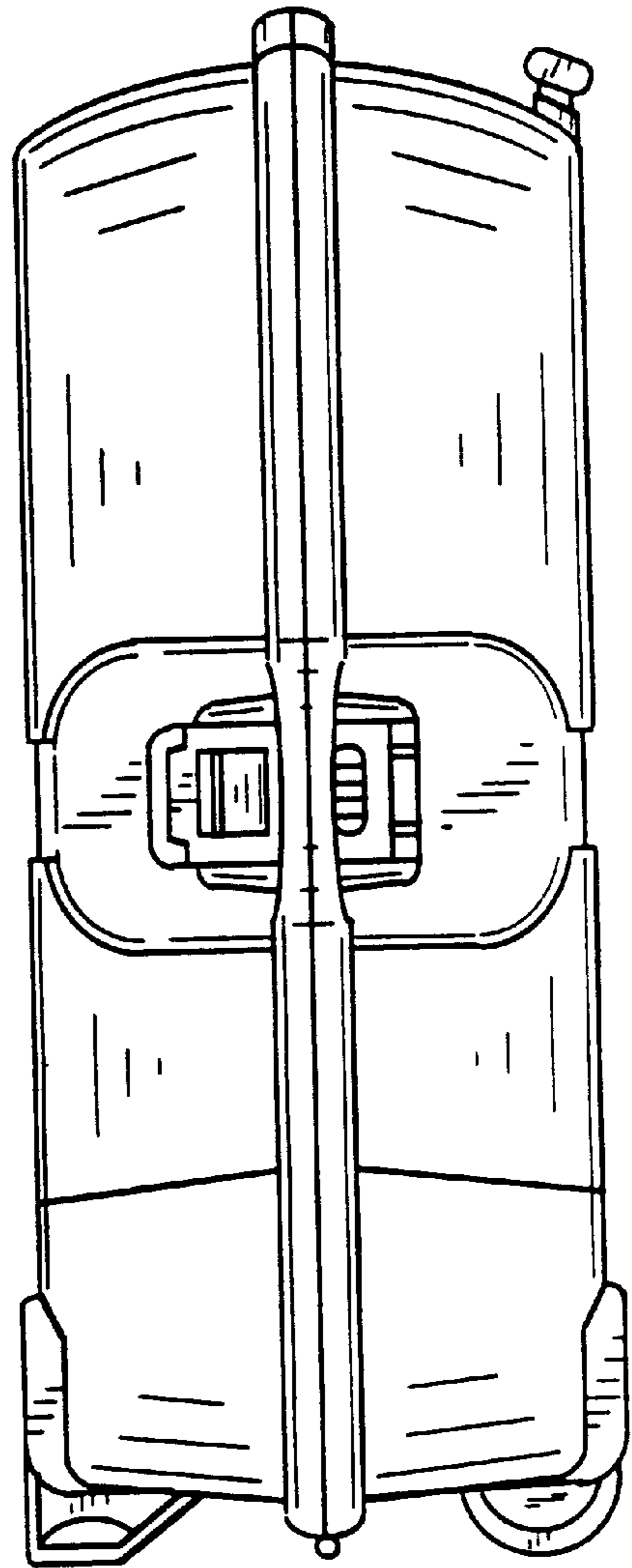

FIG. 7