



US00D434011S

United States Patent [19]

Roth et al.

[11] Patent Number: Des. 434,011

[45] Date of Patent: ** Nov. 21, 2000

[54] ELECTRONIC CONTROLLER FOR TOWED VEHICLE BRAKES

[75] Inventors: Mark R. Roth, Holland; Jason A. Reichard, Scotts, both of Mich.

[73] Assignee: Tekonsha Engineering Company, Tekonsha, Mich.

[**] Term: 14 Years

[21] Appl. No.: 29/114,133

[22] Filed: Nov. 18, 1999

Related U.S. Application Data

[63] Continuation-in-part of application No. 29/097,101, Nov. 30, 1998, abandoned.

[51] LOC (7) Cl. 13-03

[52] U.S. Cl. D13/162

[58] Field of Search D13/162, 164; D12/179, 174, 192; 188/3 R, 181 R; 200/61.45 R; 303/20, 24.1; 280/750, 752, 770

[56] References Cited

U.S. PATENT DOCUMENTS

- D. 199,904 12/1964 Nunn .
- D. 215,158 9/1969 Ozaki .
- D. 257,973 1/1981 Reid .
- D. 322,426 12/1991 Austin .
- D. 331,226 11/1992 Austin .
- D. 356,298 3/1995 Austin .

- D. 362,659 9/1995 Hedding et al. .
- D. 378,511 3/1997 Austin .
- D. 404,365 1/1999 Robertson et al. .
- D. 407,694 4/1999 Hill et al. D13/162
- D. 418,822 1/2000 Worley D13/162 X
- 3,780,832 12/1973 Marshall .
- 3,909,075 9/1975 Pittet, Jr. et al. .
- 3,953,084 4/1976 Pittet, Jr. et al. .
- 5,333,948 8/1994 Austin et al. .
- 5,615,930 4/1997 McGrath et al. .

Primary Examiner—Melody N. Brown
Attorney, Agent, or Firm—Price, Heneveld, Cooper, DeWitt & Litton

[57] CLAIM

The ornamental design for an electronic controller for towed vehicle brakes, as shown and described.

DESCRIPTION

FIG. 1 is a top, front side perspective view of an electronic controller for towed vehicle brakes showing our new design; FIG. 2 is a front view thereof; FIG. 3 is a side view showing the first side thereof; FIG. 4 is another side view showing the side opposite that shown in FIG. 3; FIG. 5 is a rear view thereof; FIG. 6 is a top view thereof; FIG. 7 is a bottom view thereof; and, FIG. 8 is a perspective view showing the bottom, rear, and side thereof.

1 Claim, 4 Drawing Sheets

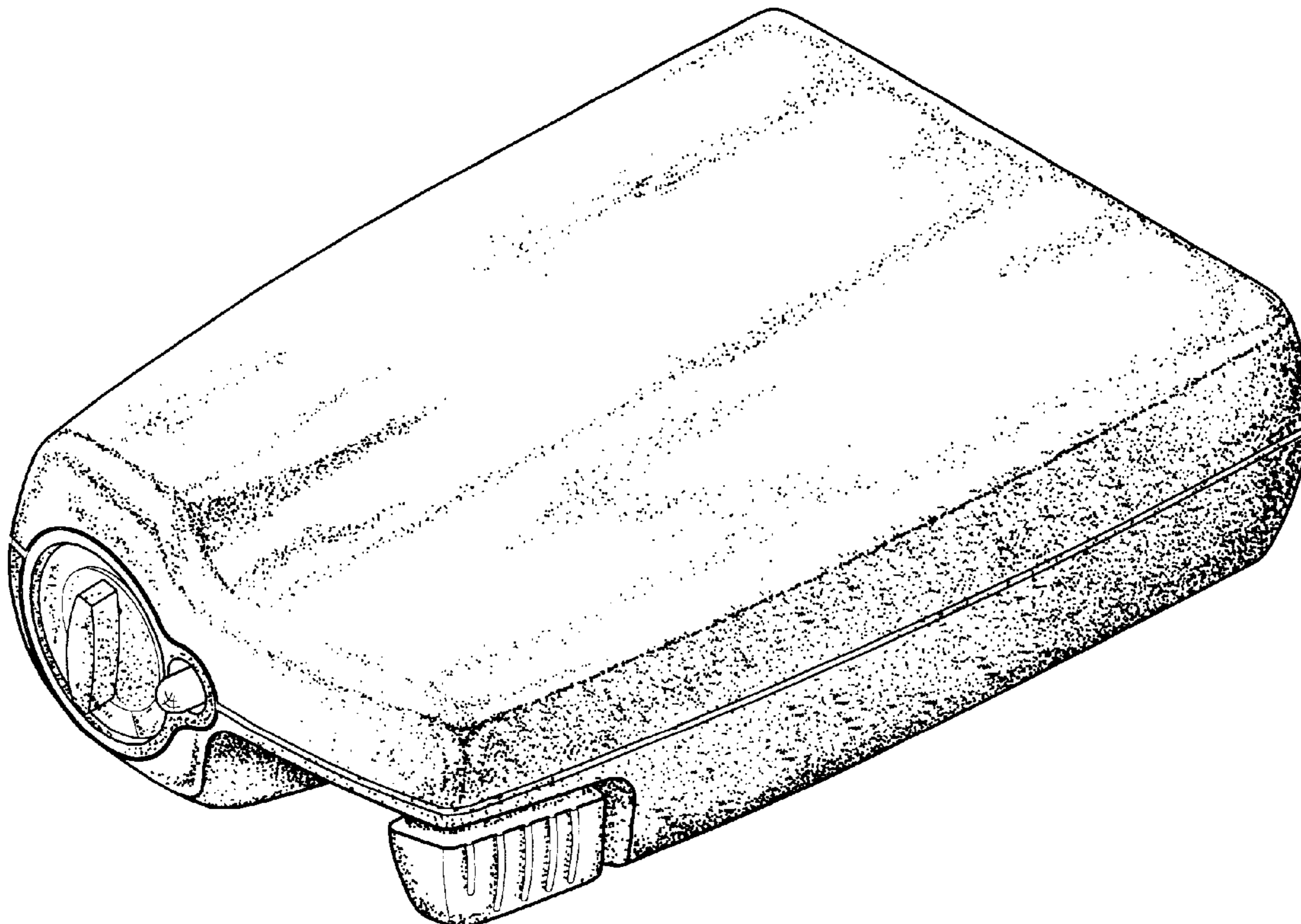

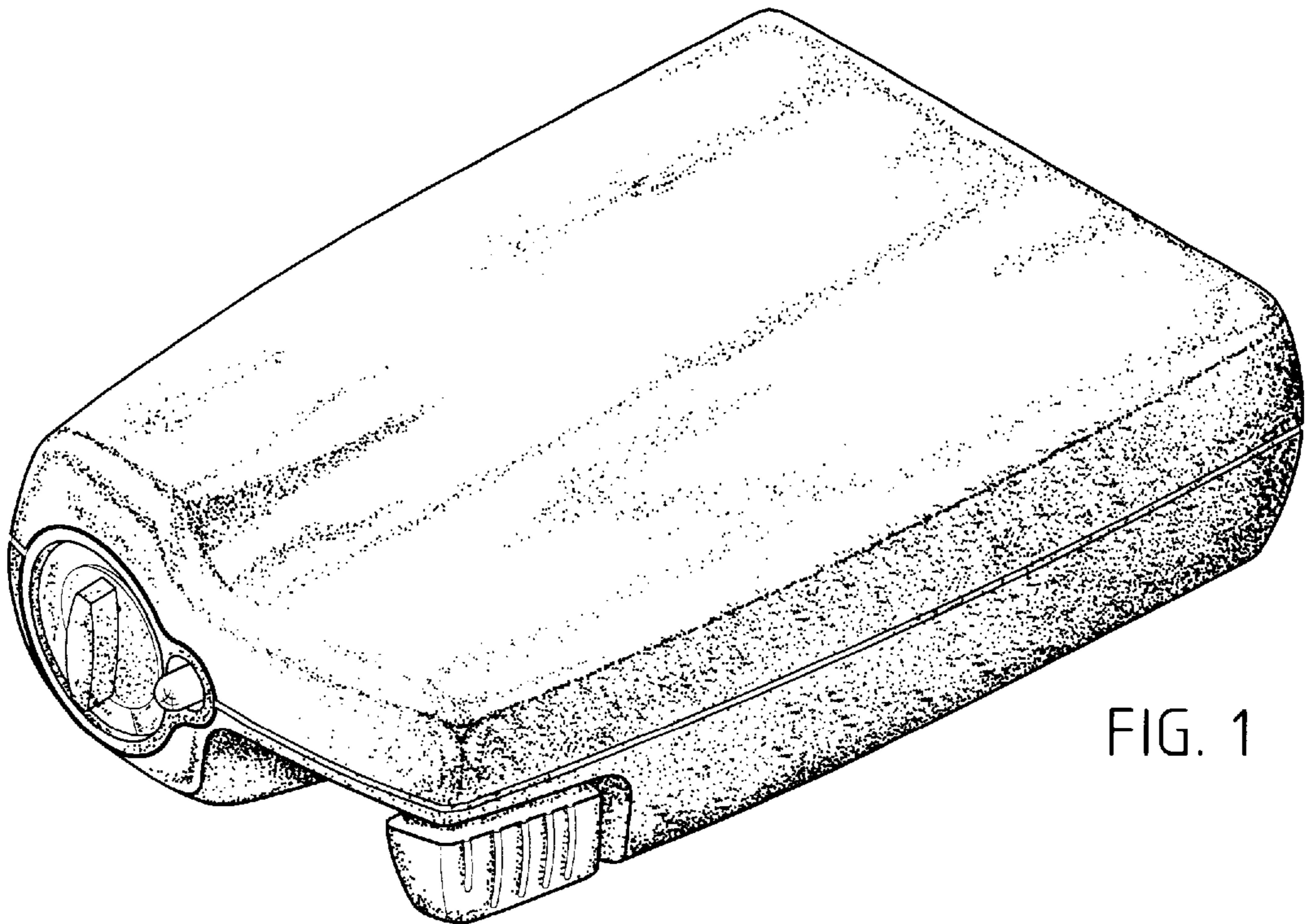

FIG. 1

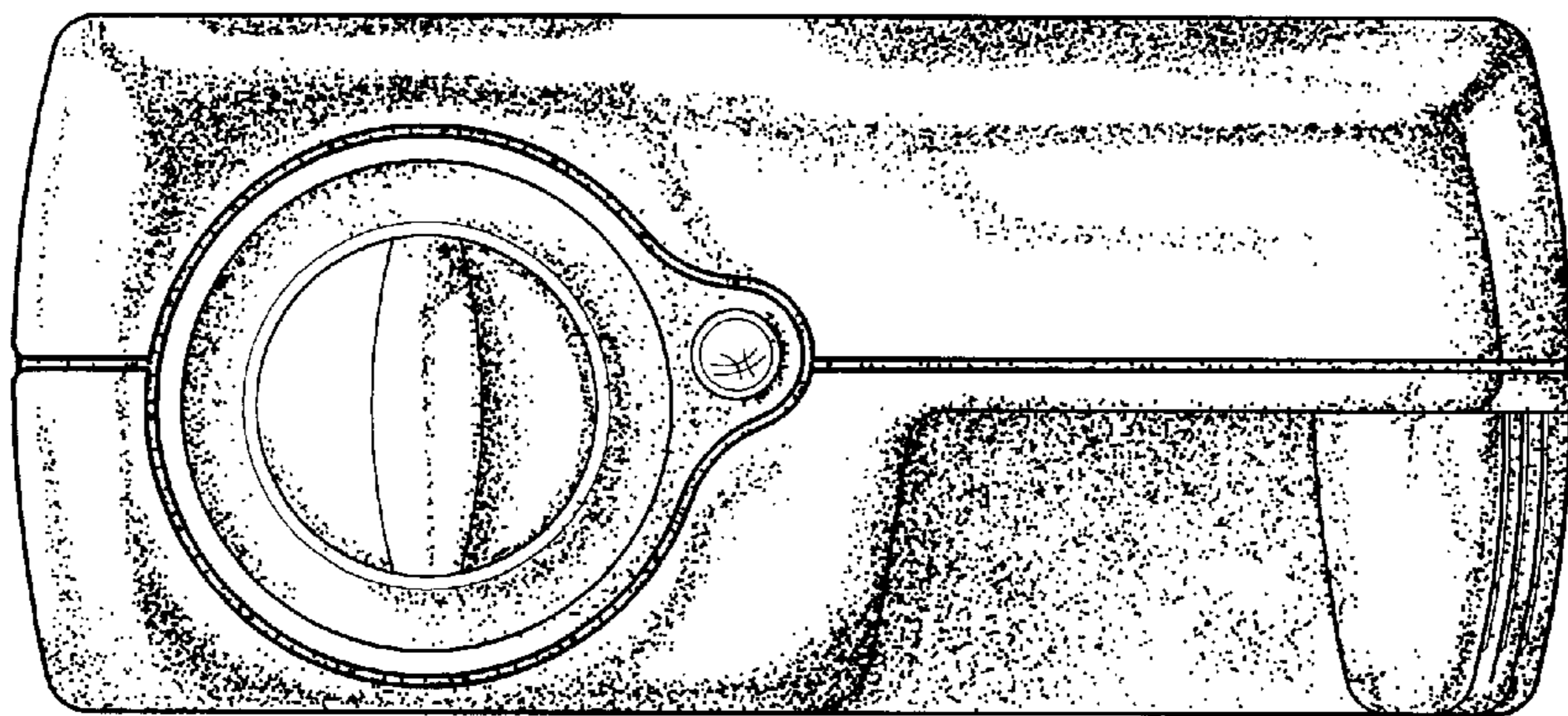

FIG. 2

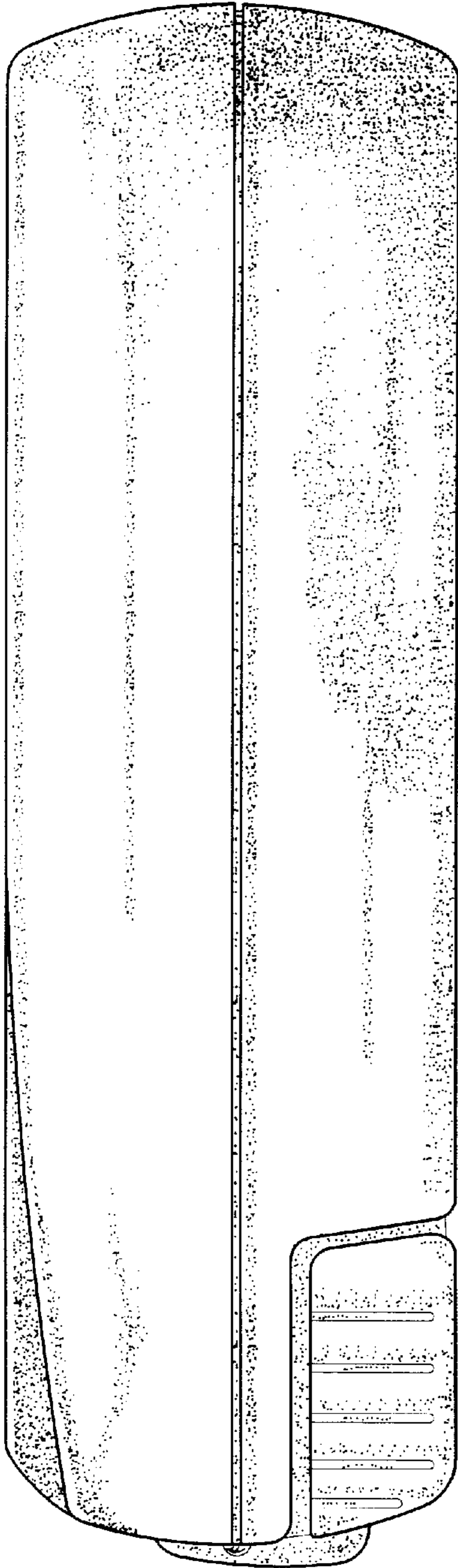

FIG. 3

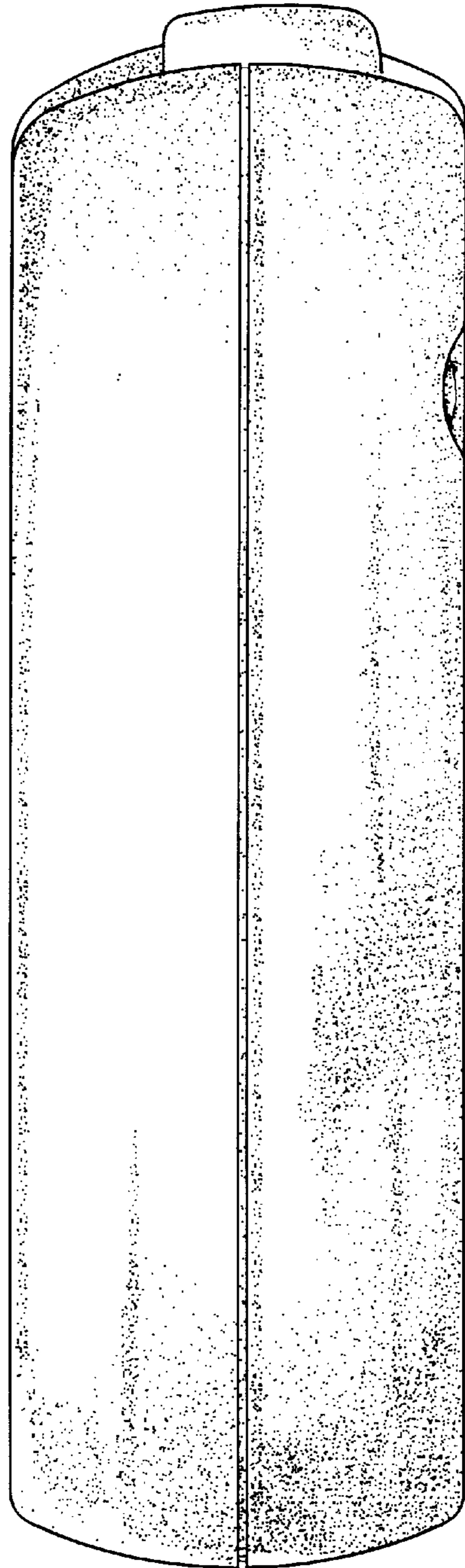

FIG. 4

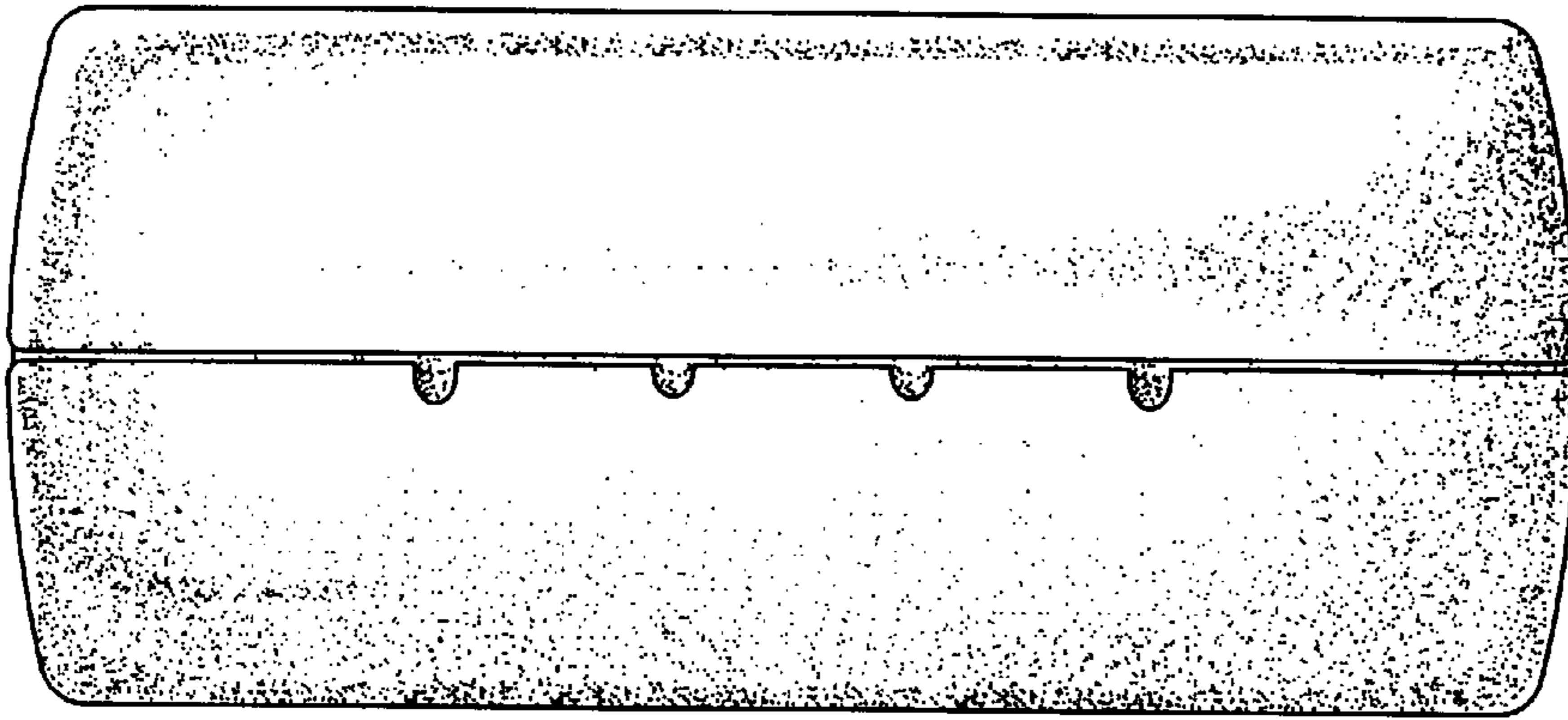

FIG. 5



FIG. 6

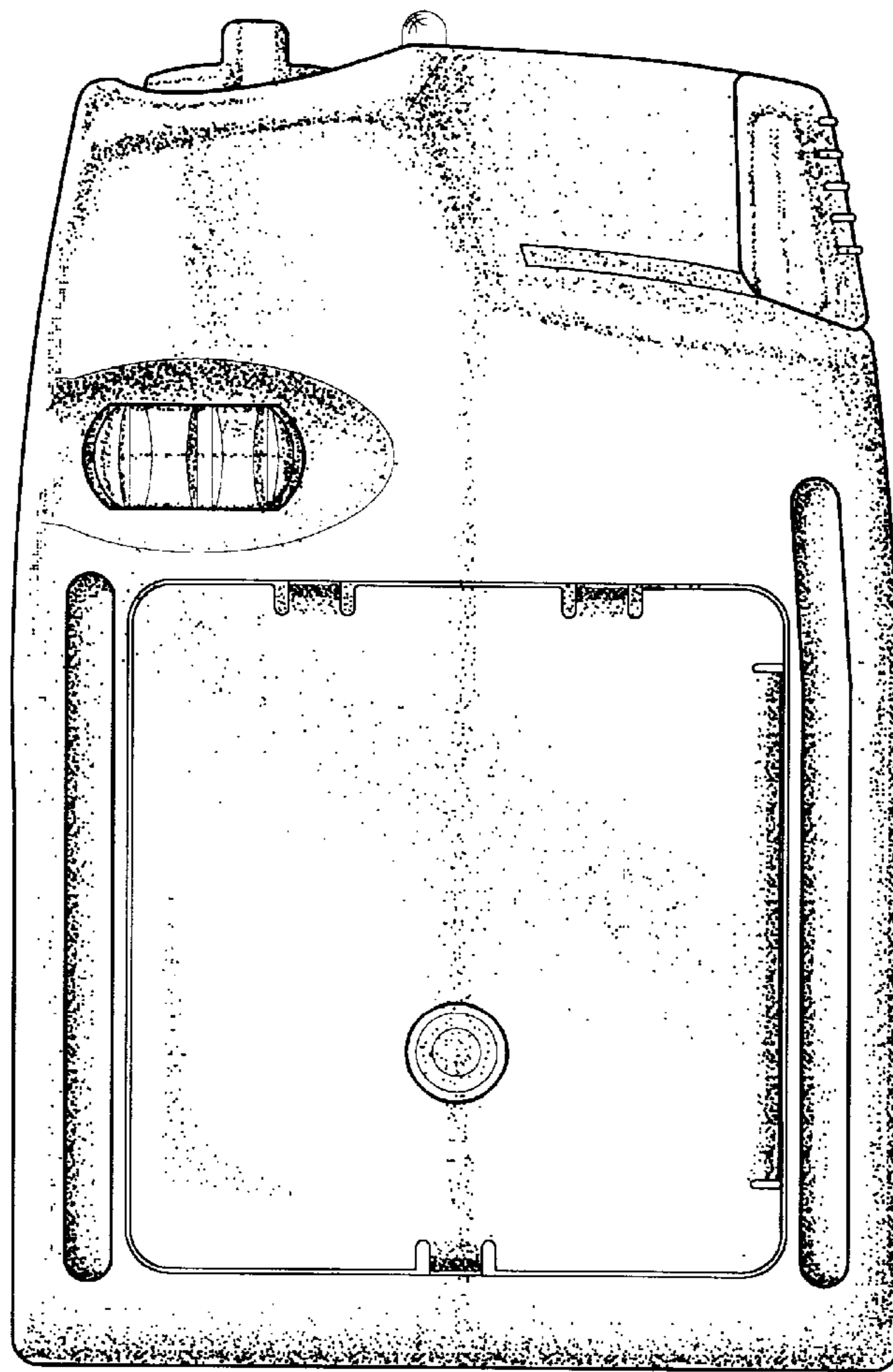

FIG. 7

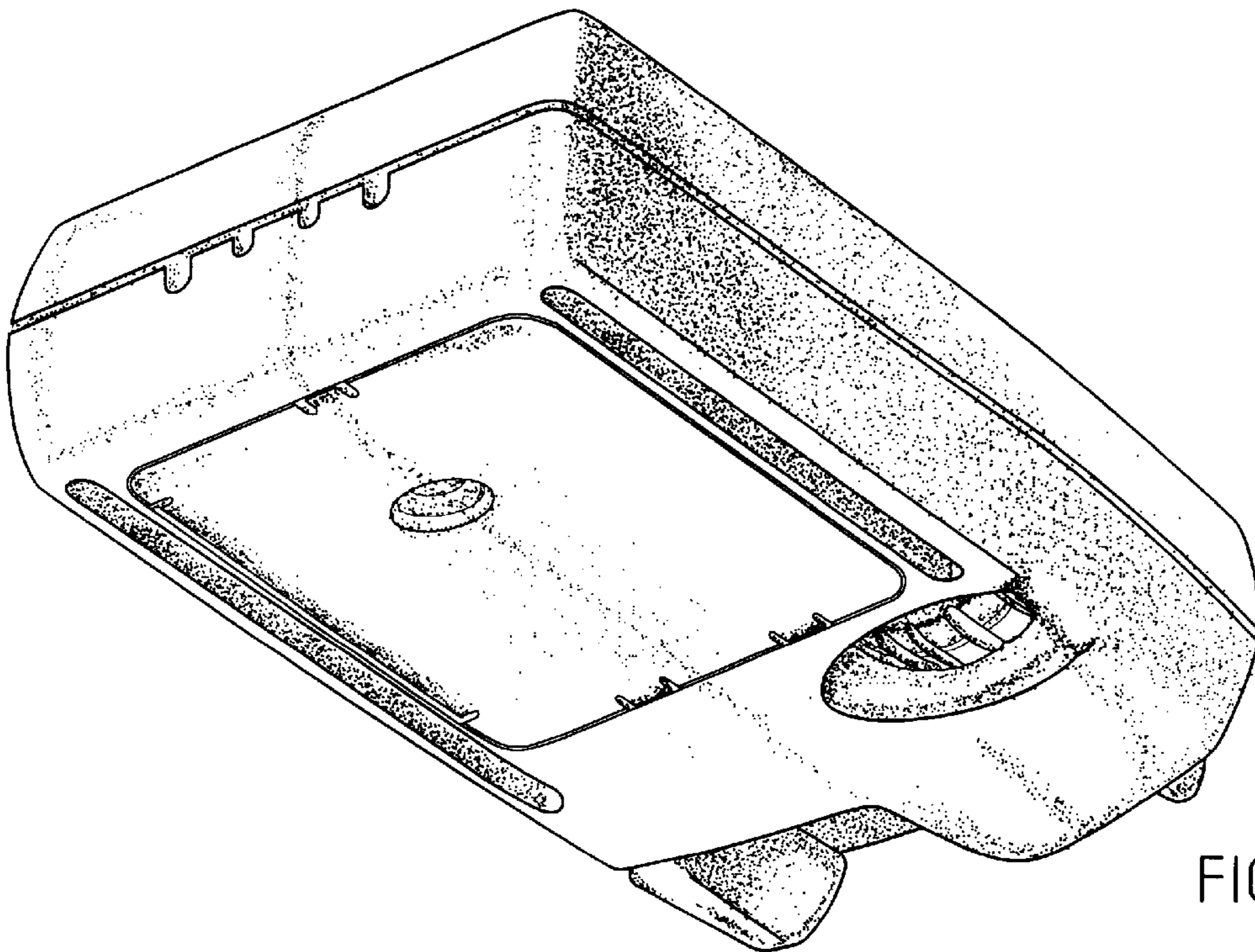

FIG. 8