



US00D433979S

United States Patent [19]

Gerding et al.

[11] Patent Number: **Des. 433,979**

[45] Date of Patent: **** Nov. 21, 2000**

[54] **TRUCK BODY TAILGATE**

[75] Inventors: **Ronald B Gerding; Ralph E Grissom, III**, both of Florence, Ala.

[73] Assignee: **The Heil Co.**, Chattanooga, Tenn.

[**] Term: **14 Years**

[21] Appl. No.: **29/084,693**

[22] Filed: **Mar. 9, 1998**

[51] **LOC (7) Cl.** **12-16**

[52] **U.S. Cl.** **D12/196**

[58] **Field of Search** D12/15, 14, 93,
D12/196; 298/23 MD, 5; 296/57.1

[56] **References Cited**

U.S. PATENT DOCUMENTS

D. 241,571 9/1976 Worthington D12/15

D. 386,128 11/1997 Gerding et al. D12/93

Primary Examiner—Melody N. Brown
Attorney, Agent, or Firm—Alan Ruderman

[57] **CLAIM**

The ornamental design for a truck body tailgate, as shown and described.

DESCRIPTION

FIG. 1 is a perspective view of a first embodiment of a truck body tailgate showing our new design;
FIG. 2 is a rear view thereof;
FIG. 3 is a side elevational view thereof;
FIG. 4 is a top plan view thereof;
FIG. 5 is a bottom plan view thereof; and
FIG. 6 is a front elevational view thereof;
FIG. 7 is a rear elevational view of a second embodiment of our new design;
FIG. 8 is a side elevational view of FIG. 7;
FIG. 9 is a top plan view of FIG. 7;
FIG. 10 is a bottom plan view of FIG. 7; and,
FIG. 11 is a front elevational view of FIG. 7.

The truck portions shown in broken lines are for illustrative purposes only and form no part of the claimed design.

1 Claim, 3 Drawing Sheets

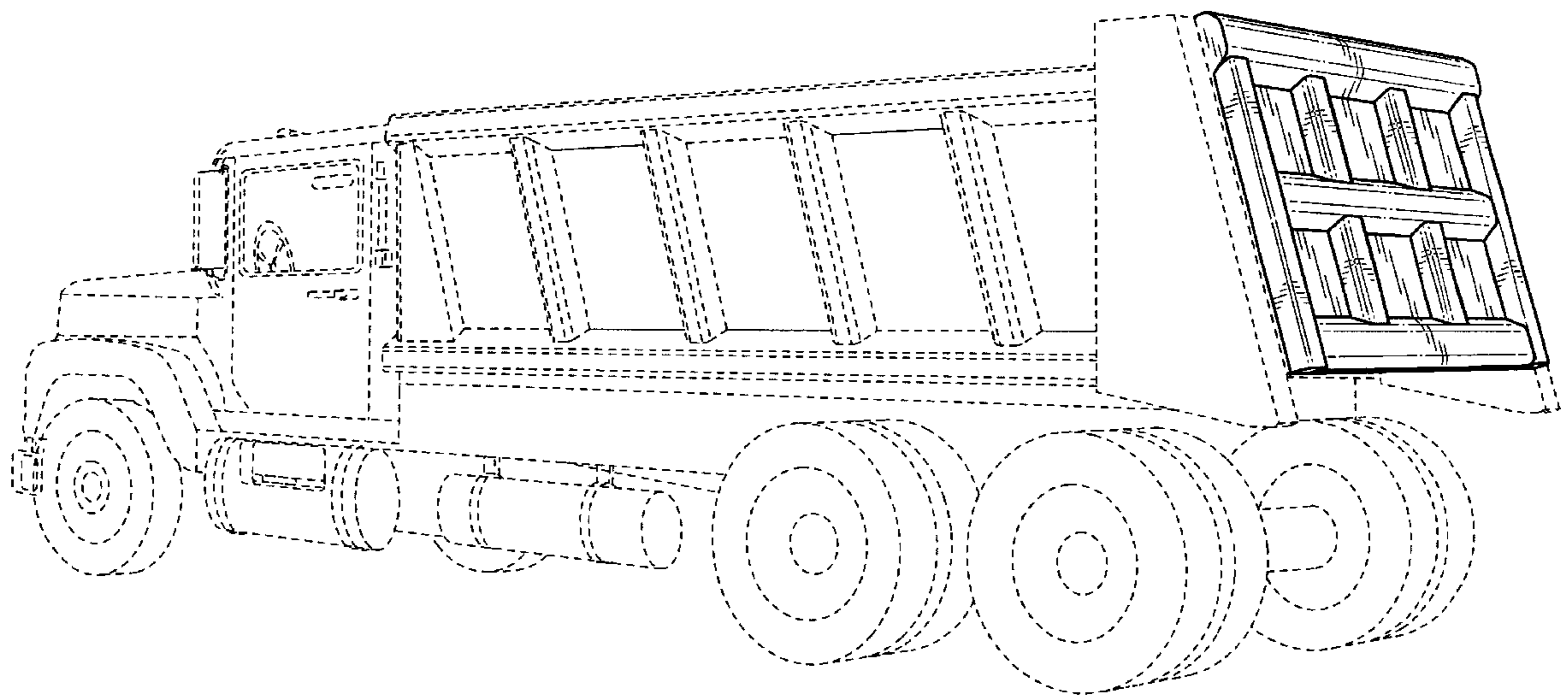

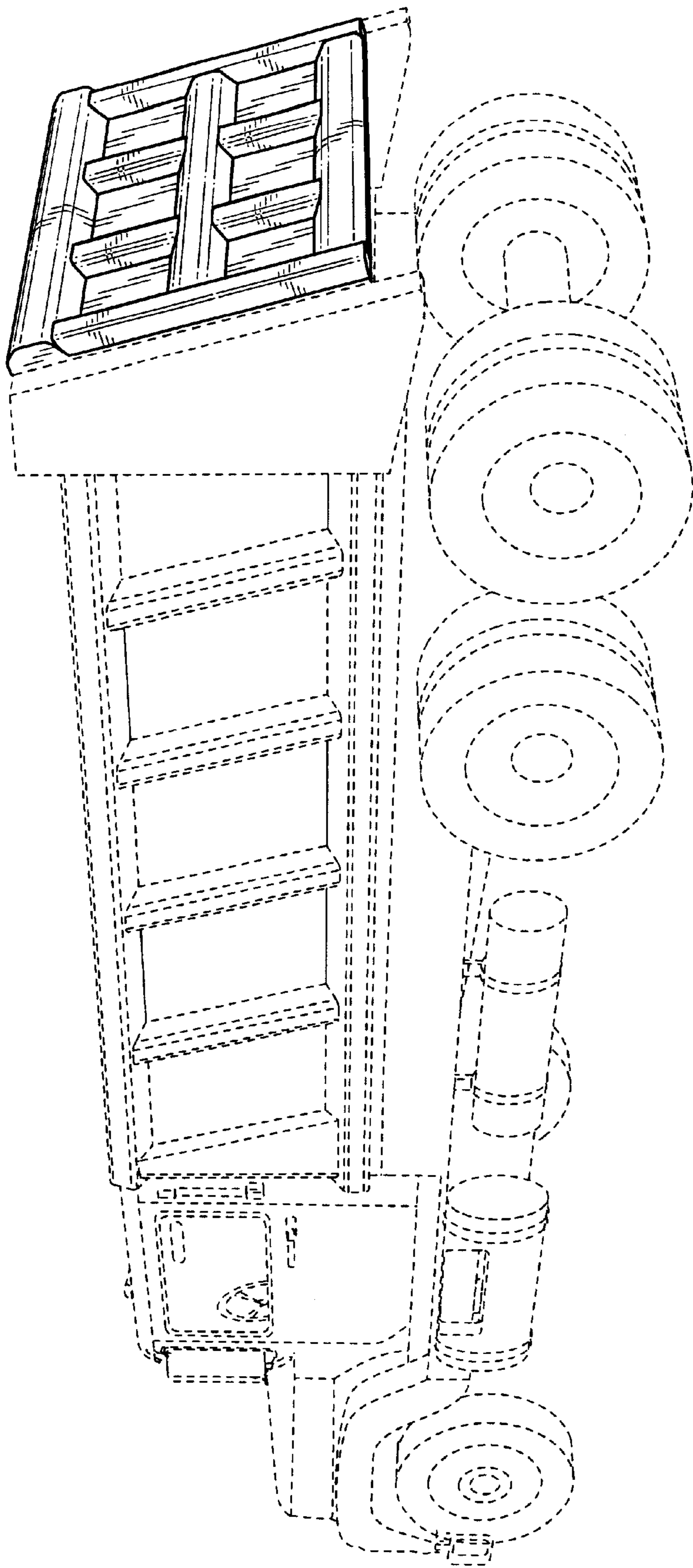

FIG. 1

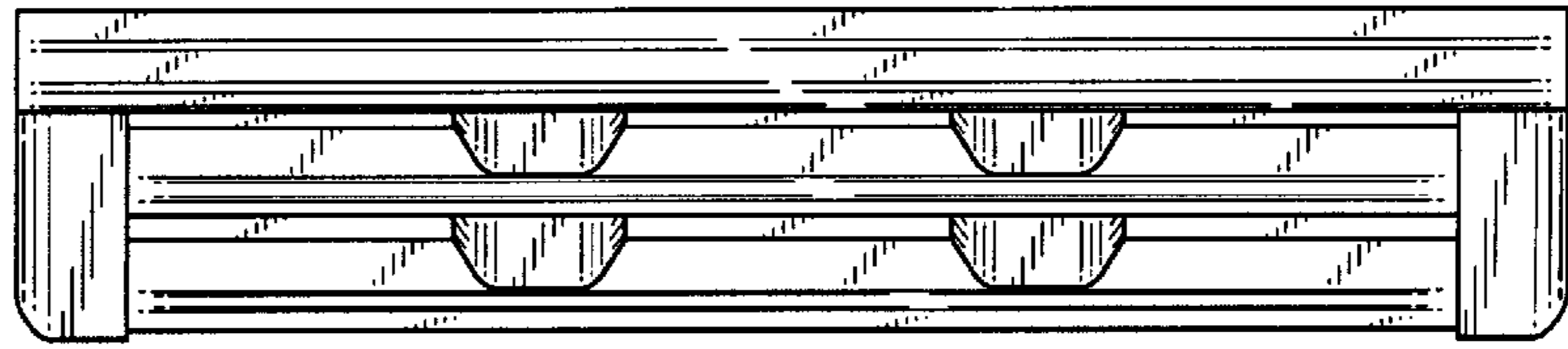

FIG. 4

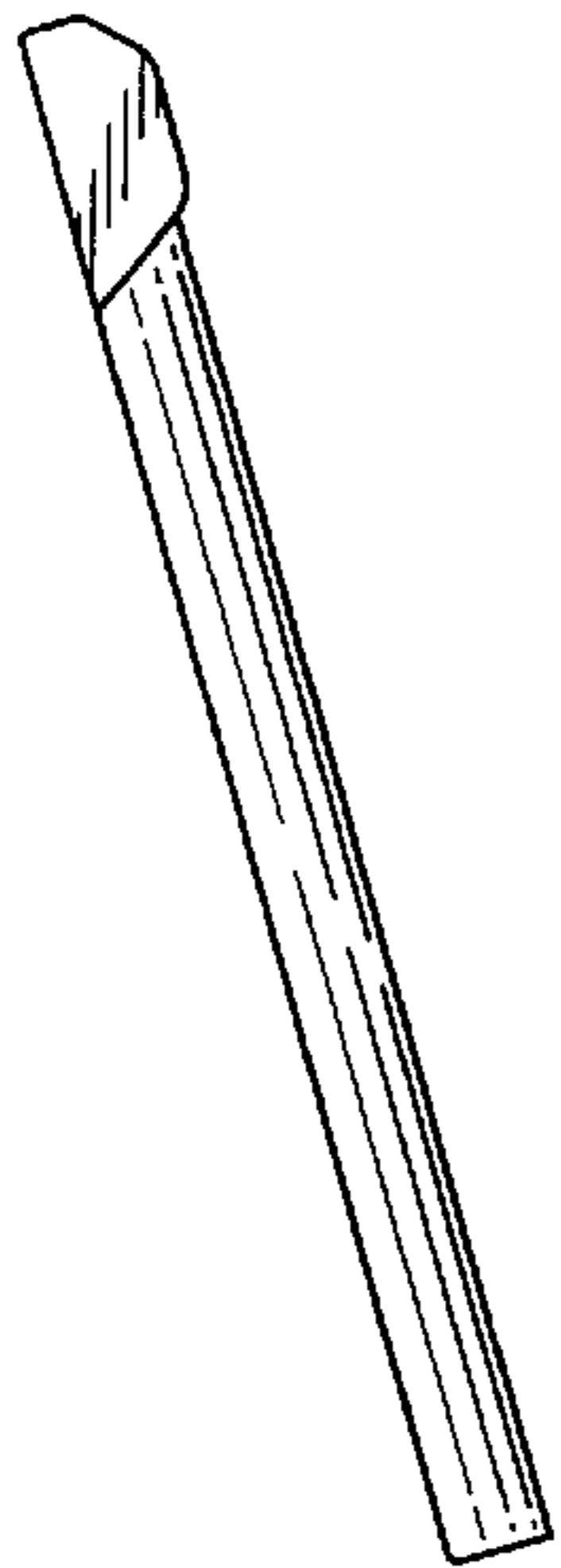

FIG. 3

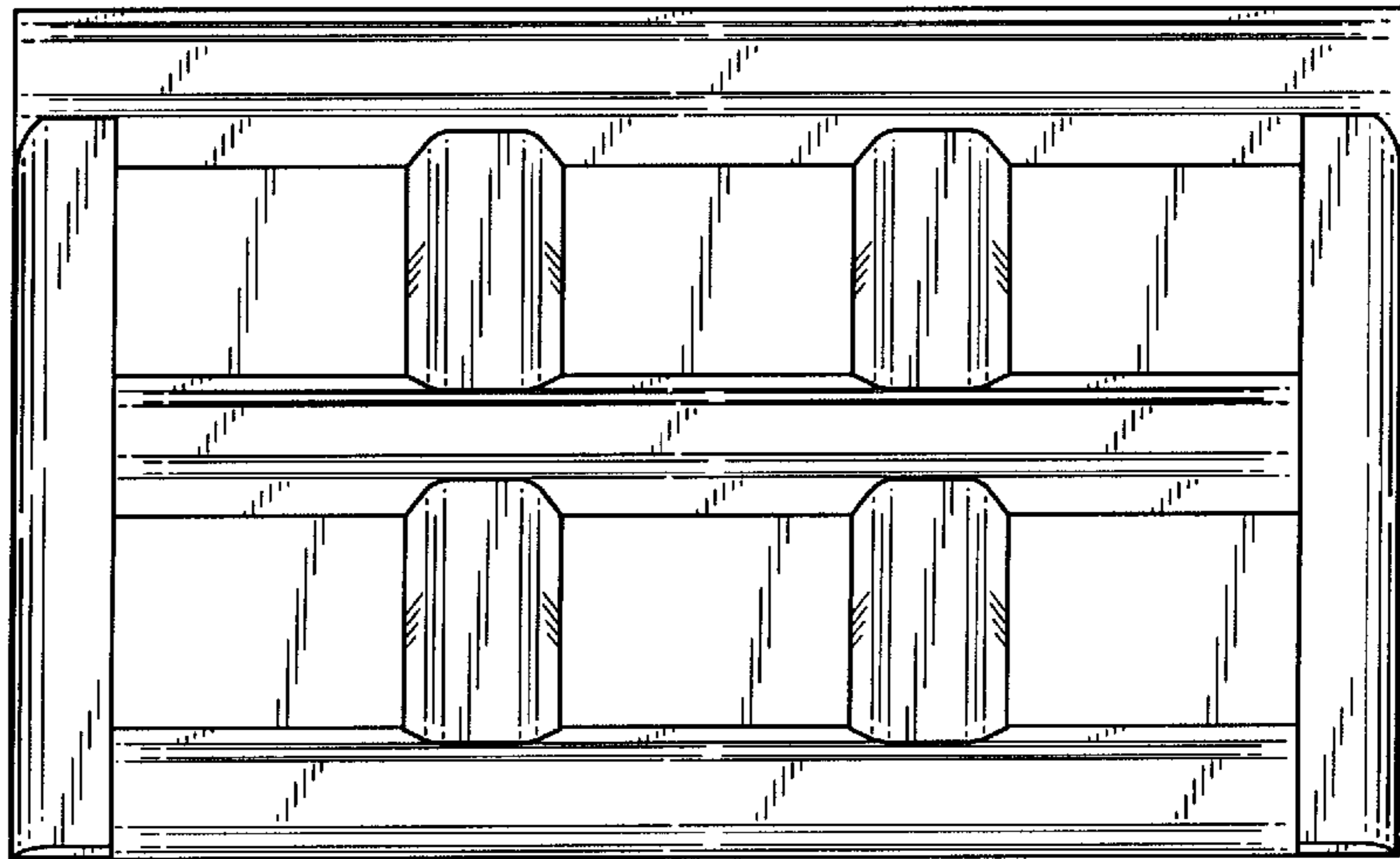

FIG. 2

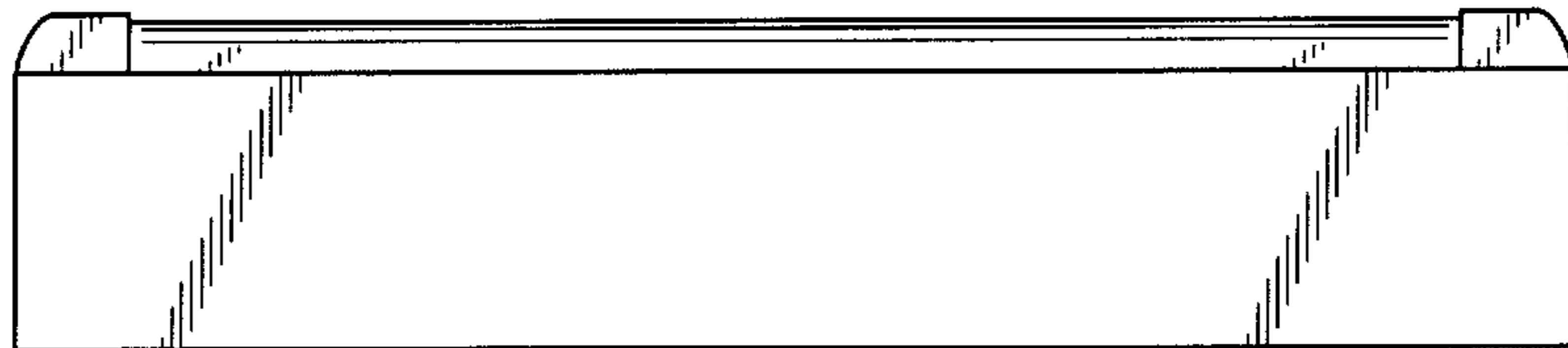

FIG. 5

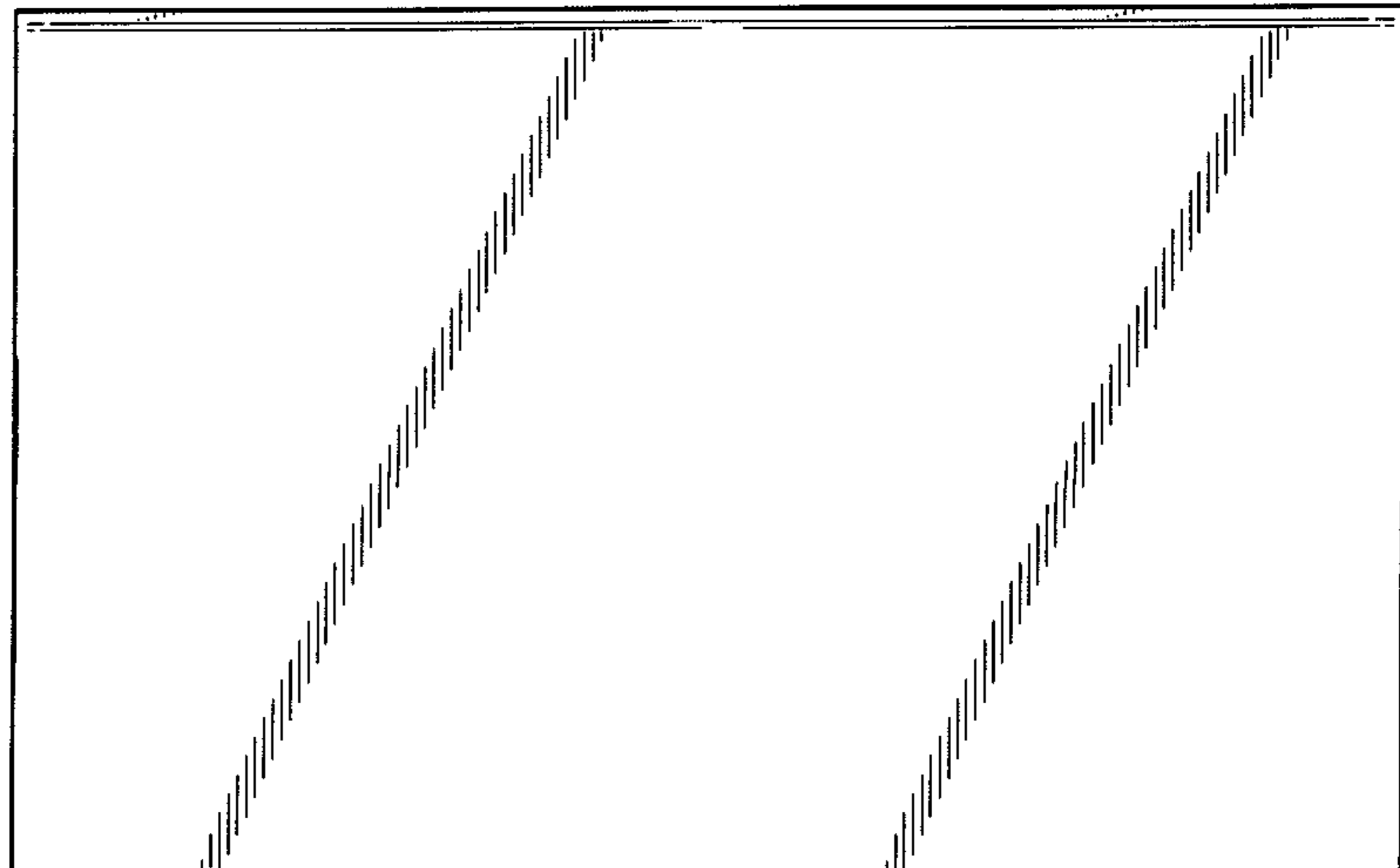

FIG. 6

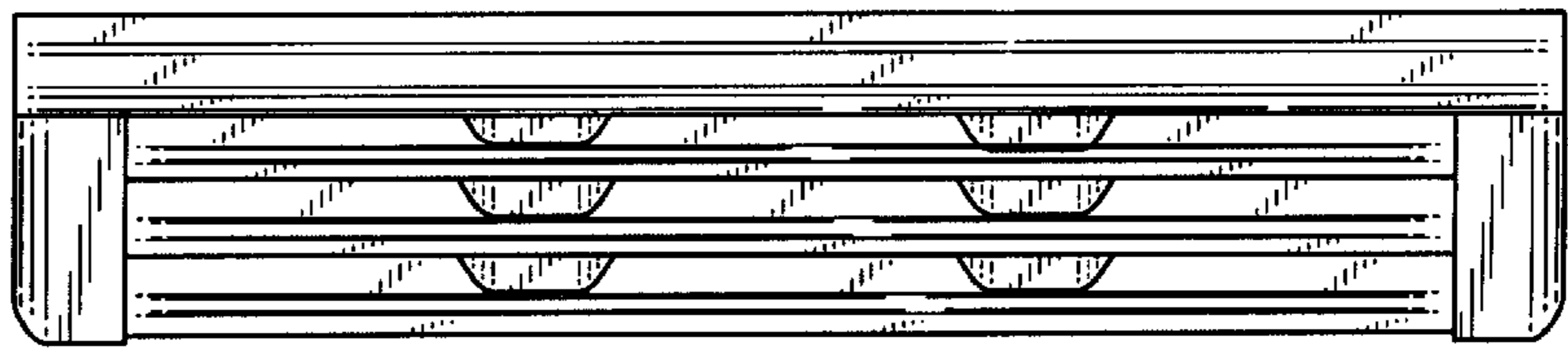

FIG. 9

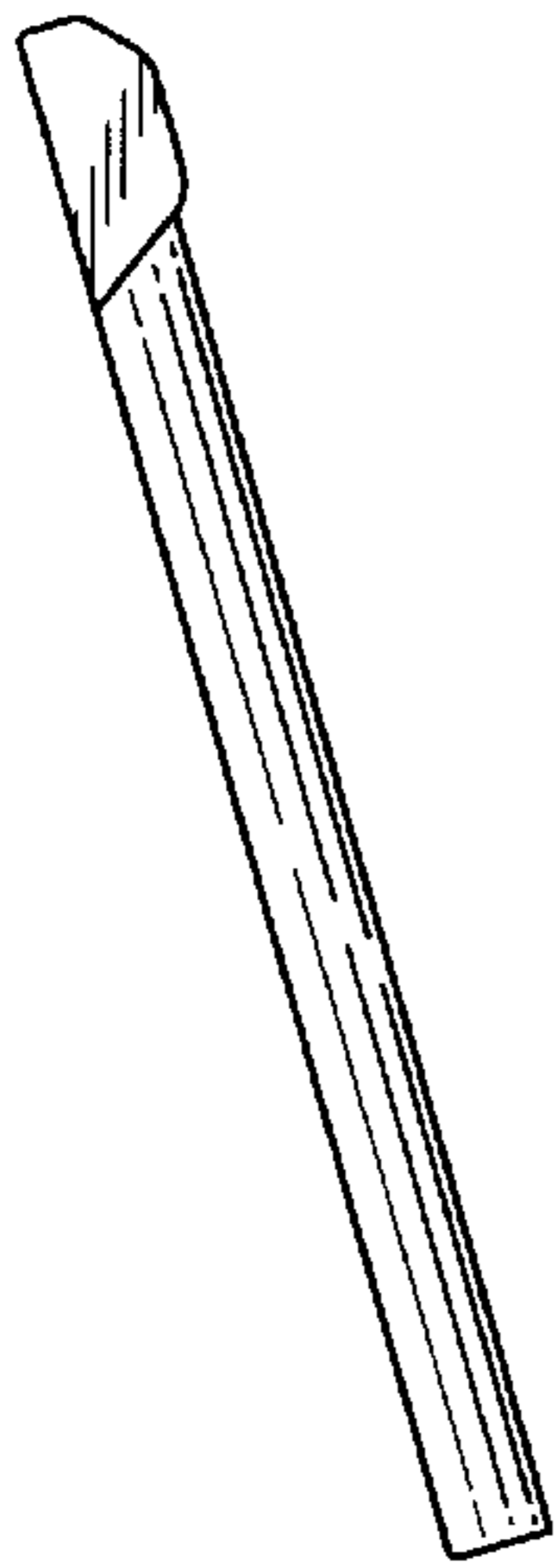

FIG. 8

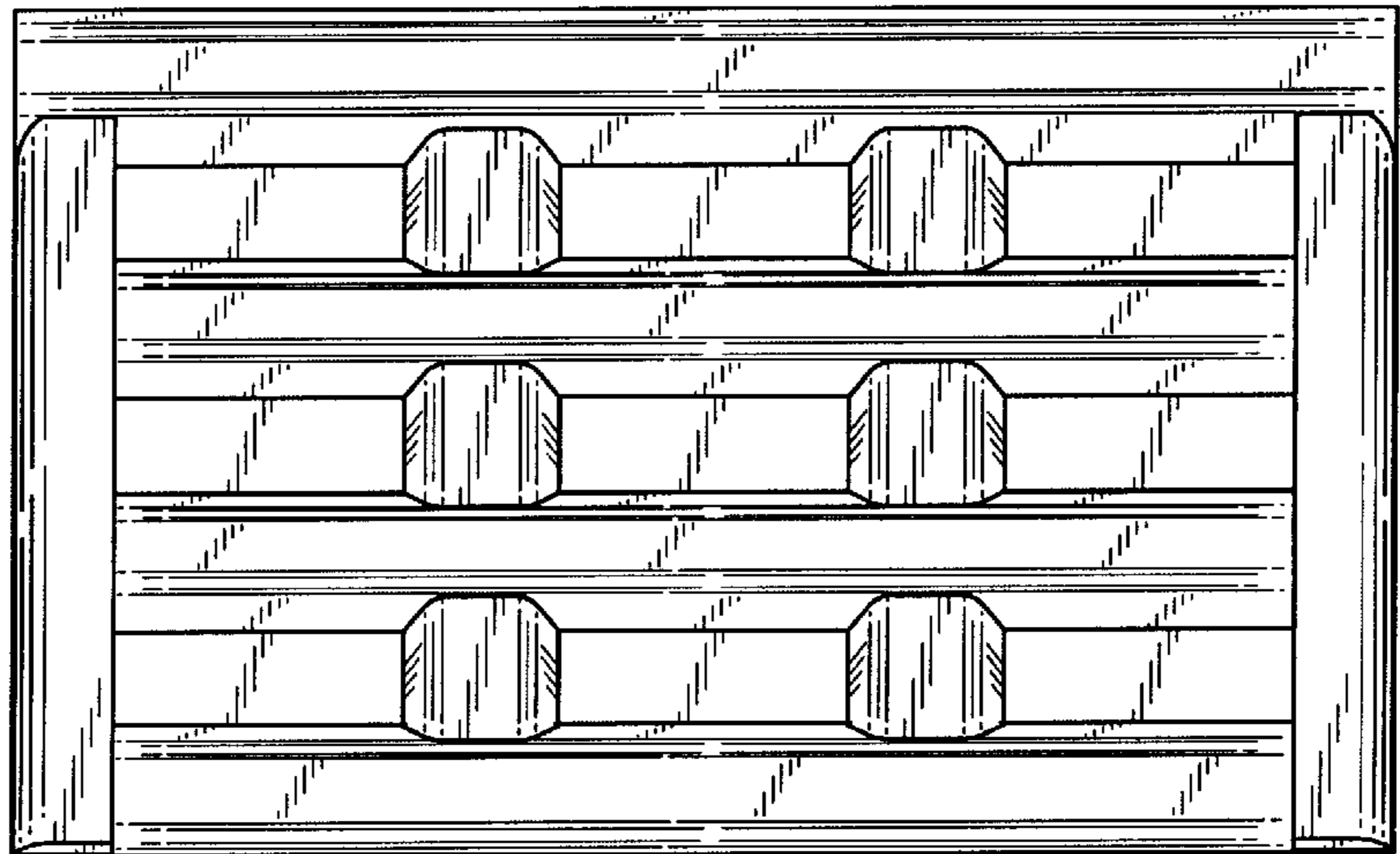

FIG. 7

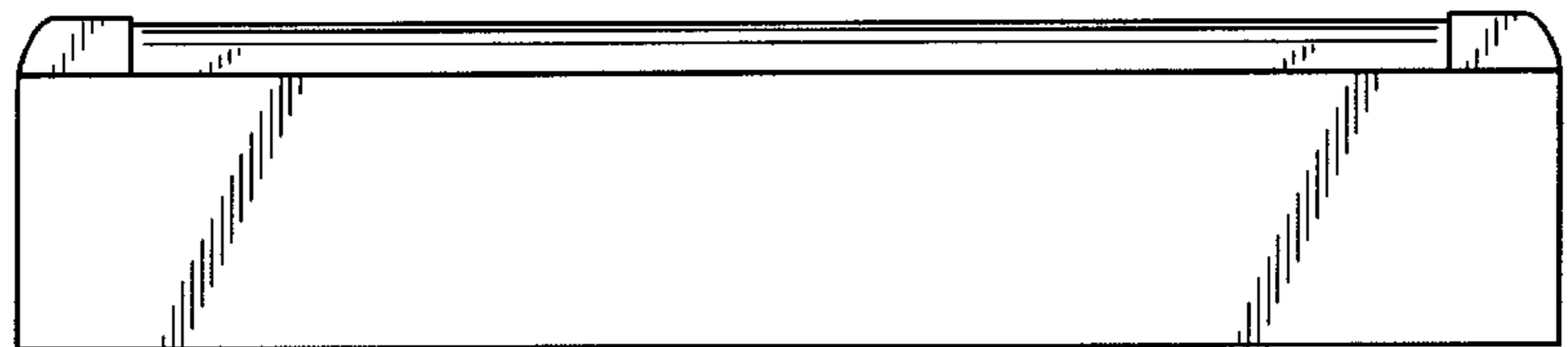

FIG. 10

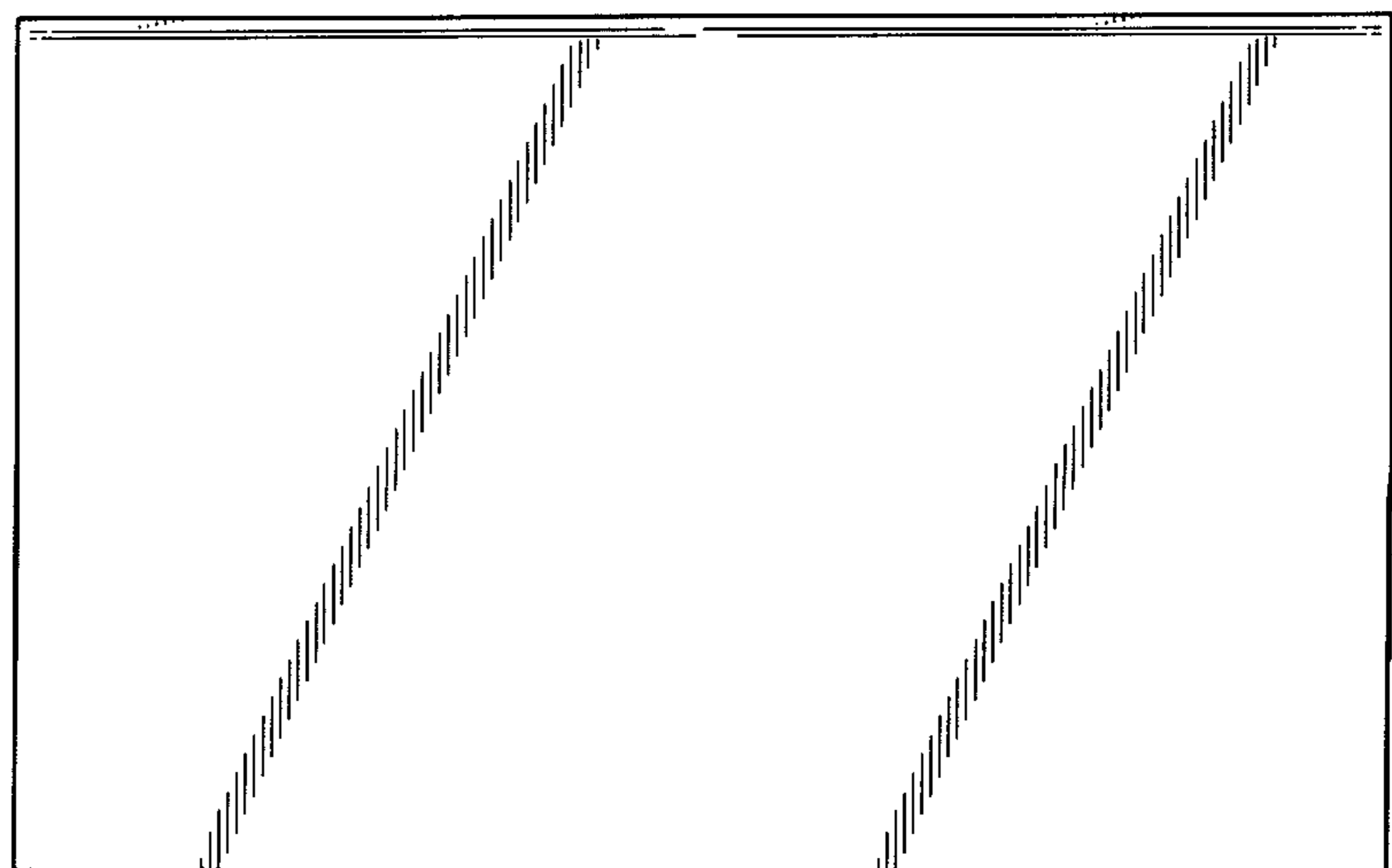

FIG. 11