



US00D433974S

United States Patent [19] Takizawa

[11] Patent Number: Des. 433,974

[45] Date of Patent: ** Nov. 21, 2000

[54] BRAKE SHOE SUPPORT BODY

[75] Inventor: Shin'ichi Takizawa, Sakai, Japan

[73] Assignee: Shimano Inc., Osaka, Japan

[**] Term: 14 Years

[21] Appl. No.: 29/120,413

[22] Filed: Mar. 21, 2000

Related U.S. Application Data

[62] Division of application No. 29/077,793, Oct. 14, 1997.

[51] LOC (7) Cl. 12-16

[52] U.S. Cl. D12/180

[58] Field of Search D12/179, 180;
188/73.1, 24.11-24.15, 24.19, 24.22

[56] References Cited

U.S. PATENT DOCUMENTS

D. 281,874	12/1985	King	D12/180
D. 295,847	5/1988	Everett	D12/180
D. 379,344	5/1997	Everett	D12/180
D. 384,018	9/1997	Nishimura	D12/179
3,305,048	2/1967	Brilando	188/24.12
3,840,093	10/1974	Hamayasu	188/24.12
5,655,629	8/1997	Takizawa et al.	188/24.12

Primary Examiner—Alan P. Douglas

Assistant Examiner—Linda Brooks

Attorney, Agent, or Firm—Shinju Global IP Counselors, LLP

[57] CLAIM

The ornamental design for a brake shoe support body, as shown and described.

DESCRIPTION

FIG. 1 is a perspective view of the brake shoe support body showing my new design in accordance with the present invention, with a brake pad and an attachment screw shown in broken lines;

FIG. 2 is a bottom view of the brake shoe support body depicted in FIG. 1, showing my new design, with the attachment screw and brake pad removed for clarity;

FIG. 3 is a side view of the brake shoe support body depicted in FIG. 1, showing my new design, with the attachment screw and brake pad removed for clarity;

FIG. 4 is a top view of the brake shoe support body depicted in FIG. 1, showing my new design, with the attachment screw and brake pad removed for clarity; and,

FIG. 5 is an end view of the brake shoe support body depicted in FIG. 1, showing my new design, with the attachment screw and brake pad removed for clarity.

A view showing the portion of the brake shoe support body where the brake pad is attached is not provided because there is no ornamentation on that surface of the brake shoe support body. A further end view of each embodiment of the brake shoe support body is not provided because the end views are generally mirror images of one another.

The broken line showing of environment features shown throughout the drawings are for illustrative purposes only and forms no part of the claimed design.

1 Claim, 2 Drawing Sheets

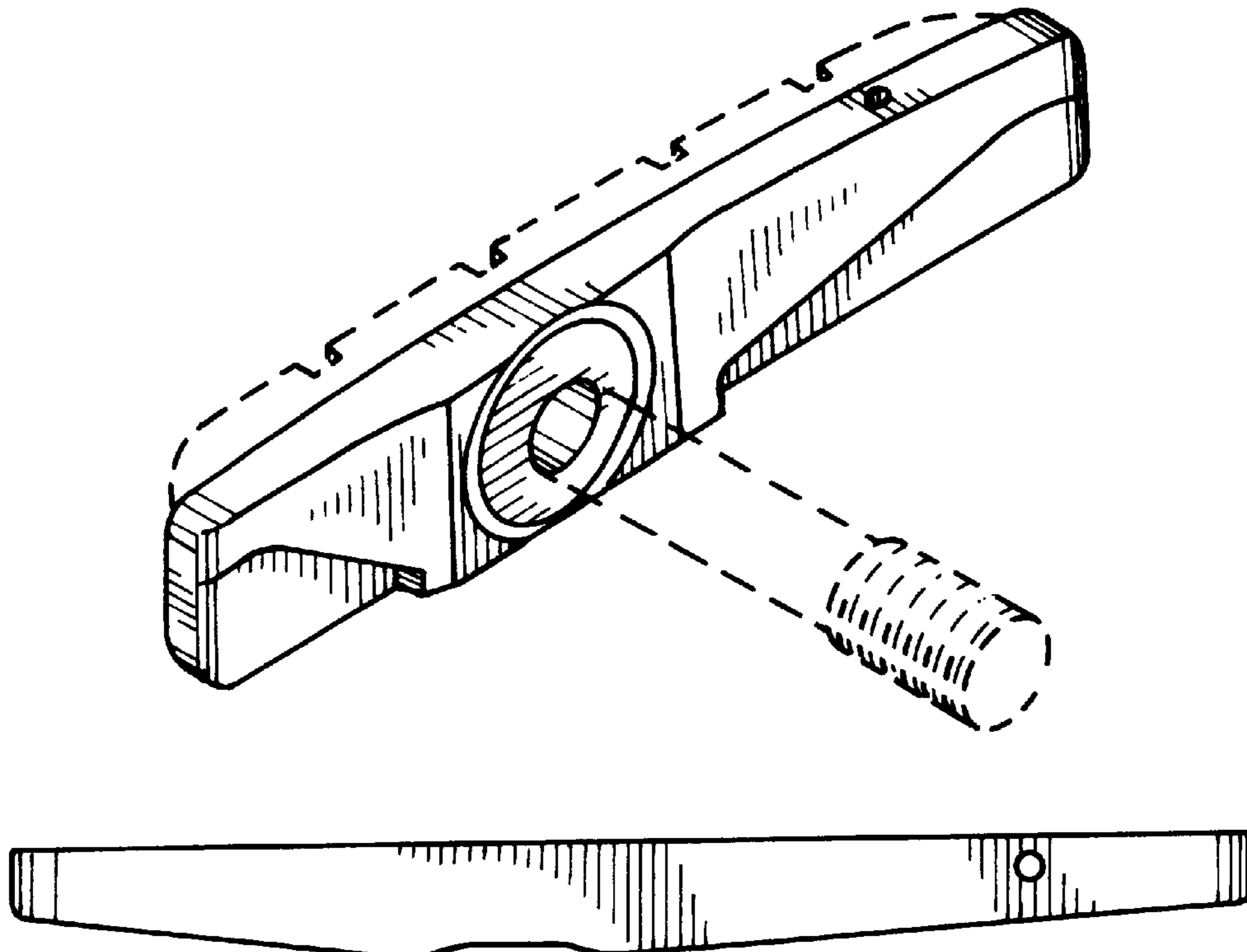

FIG. 1

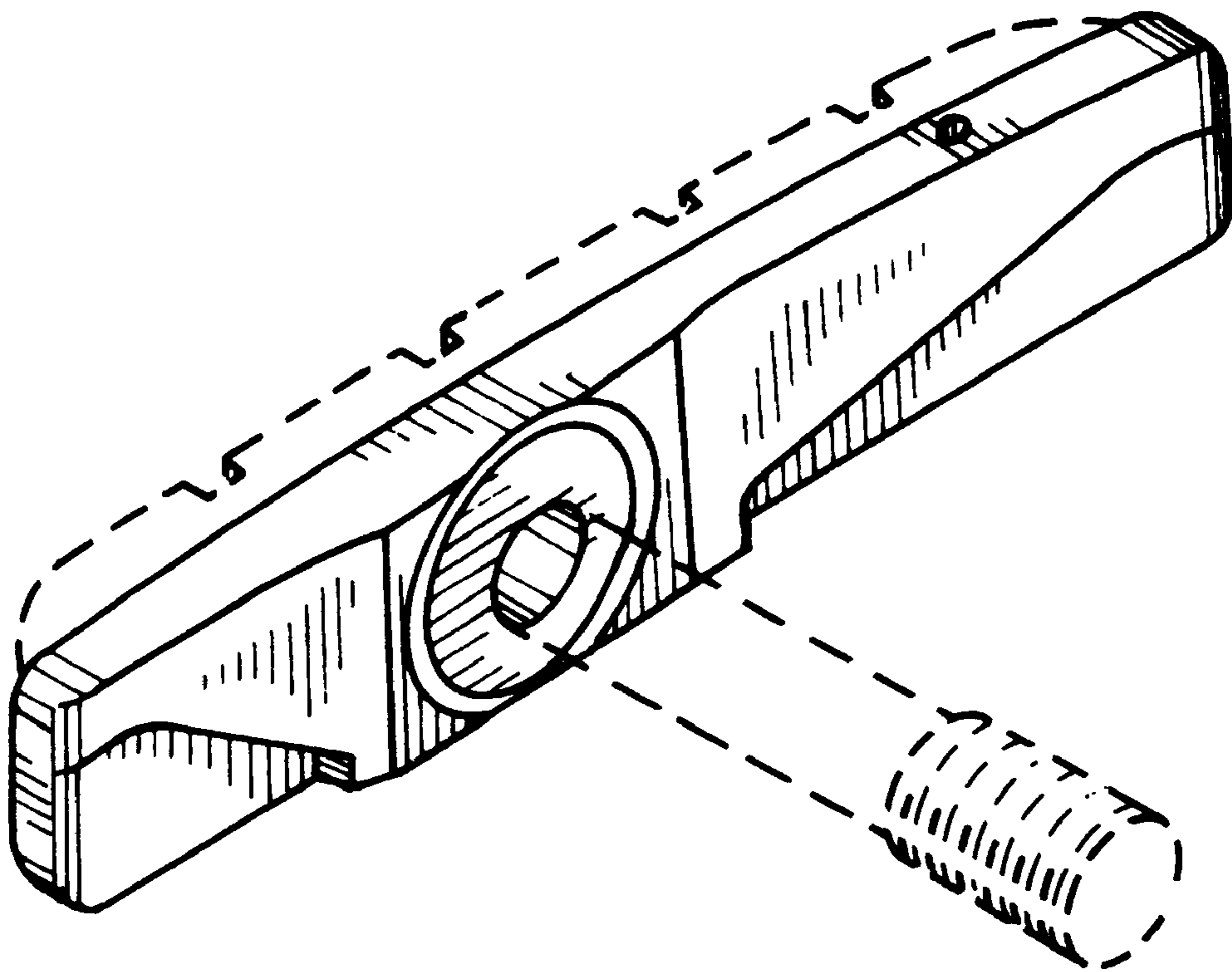

FIG. 2

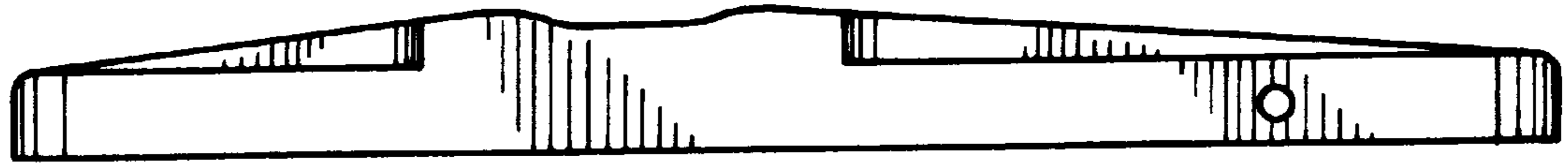

FIG. 3

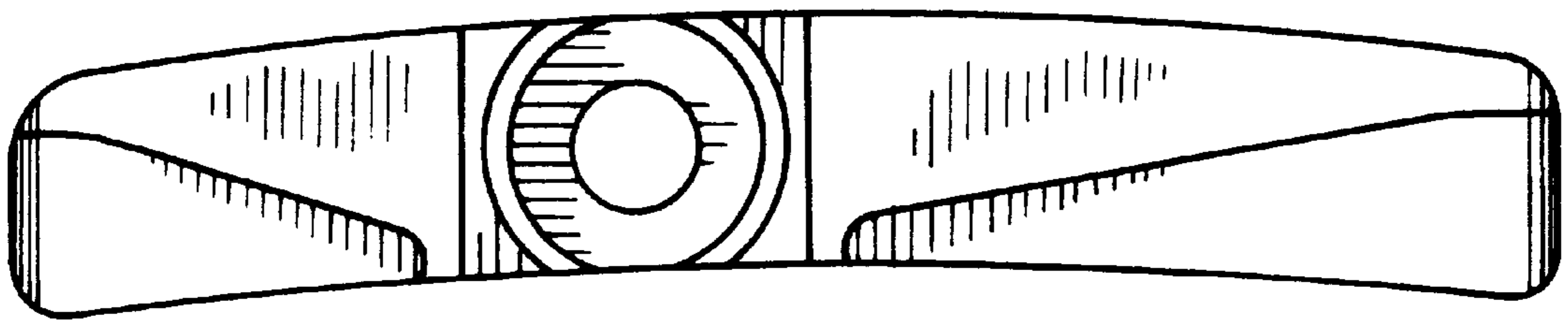

FIG. 4

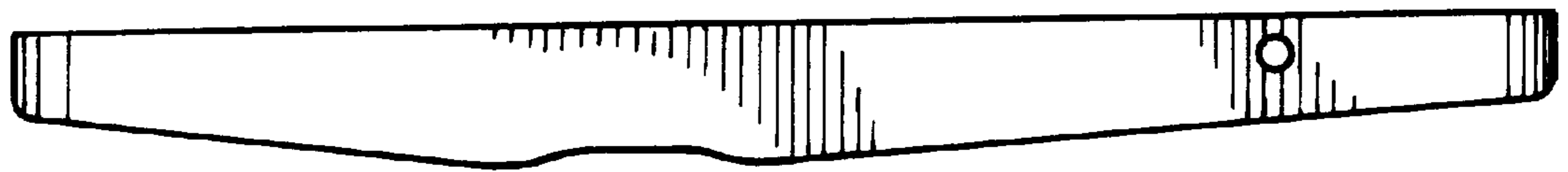

FIG. 5

