



US00D433967S

# United States Patent [19]

[11] **Patent Number: Des. 433,967**

**Delashaw et al.**

[45] **Date of Patent: \*\* Nov. 21, 2000**

## [54] EXTERIOR SURFACE CONFIGURATION OF A BATTERY BOX FAIRING FOR A TRUCK

[75] Inventors: **Bryan W. Delashaw**, Frisco; **Louis D. Heilaneh**, Lewisville, both of Tex.

[73] Assignee: **Paccar Inc**, Bellevue, Wash.

[\*\*] Term: **14 Years**

[21] Appl. No.: **29/117,263**

[22] Filed: **Jan. 20, 2000**

[51] **LOC (7) Cl.** ..... **12-16**

[52] **U.S. Cl.** ..... **D12/96**

[58] **Field of Search** ..... D12/96, 97, 196,  
D12/203, 181; 296/183, 193, 197, 196,  
180.2

### [56] **References Cited**

#### U.S. PATENT DOCUMENTS

D. 312,609	12/1990	Preslik et al.	.....	D12/96
D. 312,810	12/1990	Preslik et al.	.....	D12/203
D. 313,954	1/1991	Fingerle	.....	D12/96
D. 319,036	8/1991	Fingerle	.....	D12/96
D. 320,582	10/1991	Fingerle	.....	D12/96
D. 381,949	8/1997	Barrett, Jr. et al.	.....	D12/203
D. 395,848	7/1998	Meryman et al.	.....	D12/97
D. 406,553	3/1999	Hellhake et al.	.....	D12/96
D. 420,622	2/2000	Hellhake et al.	.....	D12/97

## OTHER PUBLICATIONS

Commercial Carrier Journal, Feb. 1994, p. 85, The Kenworth truck side fairing.

*Primary Examiner*—Melody N. Brown  
*Attorney, Agent, or Firm*—Sidley & Austin

## [57] **CLAIM**

The ornamental design for an exterior surface configuration of a battery box fairing for a truck, as shown and described.

## DESCRIPTION

FIG. 1 is a perspective view of an exterior surface configuration of a battery box fairing for a truck showing a first embodiment of our new design; FIG. 2 is a front view thereof; FIG. 3 is a right side view thereof; FIG. 4 is a left side view thereof; FIG. 5 is a top view thereof; FIG. 6 is a bottom view thereof; FIG. 7 is a reduced perspective view thereof; and, FIG. 8 is a reduced perspective view of an exterior surface configuration of a battery box fairing for a truck showing a second embodiment of our new design which is identical to that shown in FIGS. 1-7 except it is mirror symmetrical. The broken line showing of adjacent truck parts in FIGS. 1-8 is only for showing the surrounding environment and is not part of the claimed design.

**1 Claim, 7 Drawing Sheets**

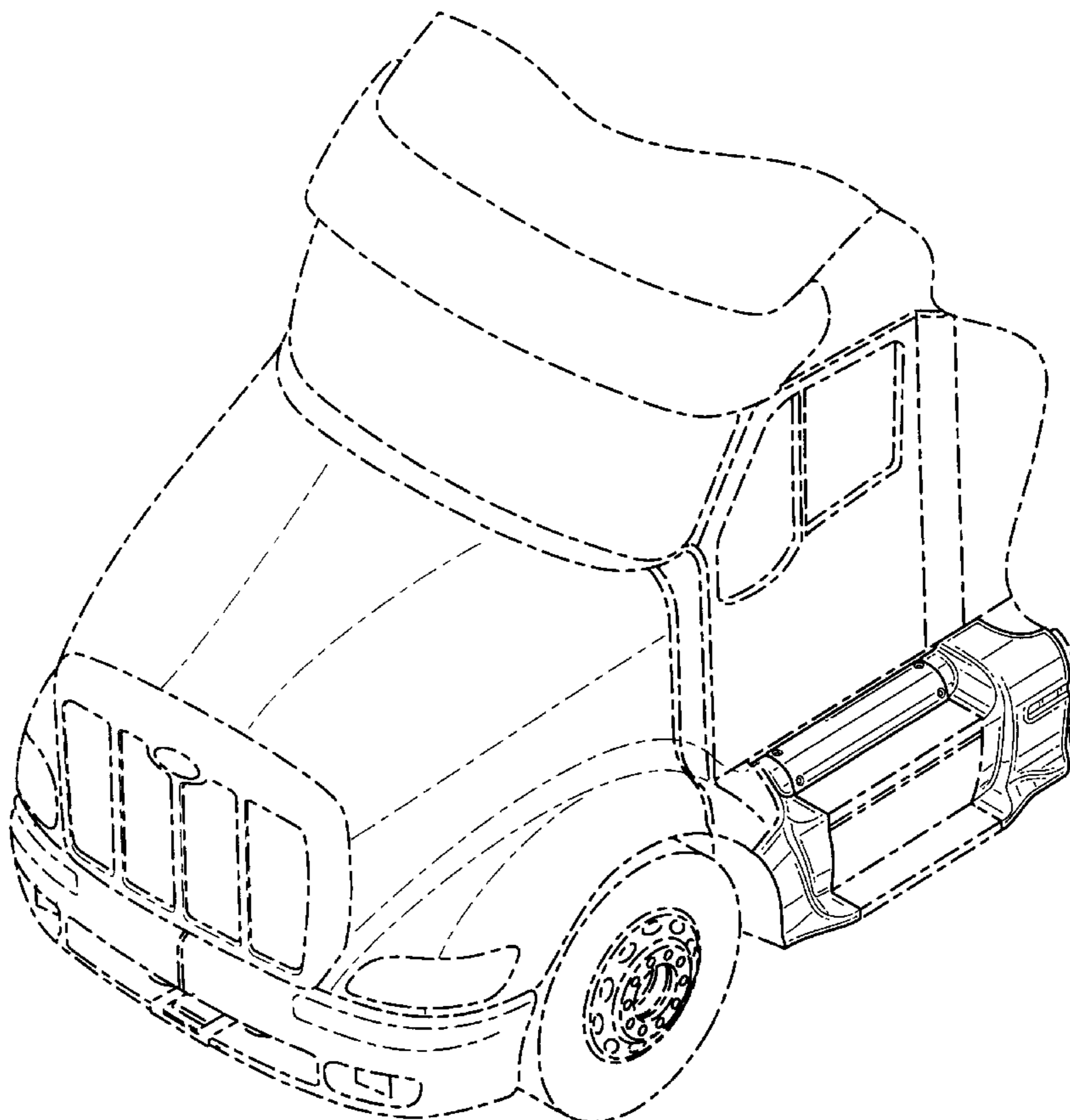

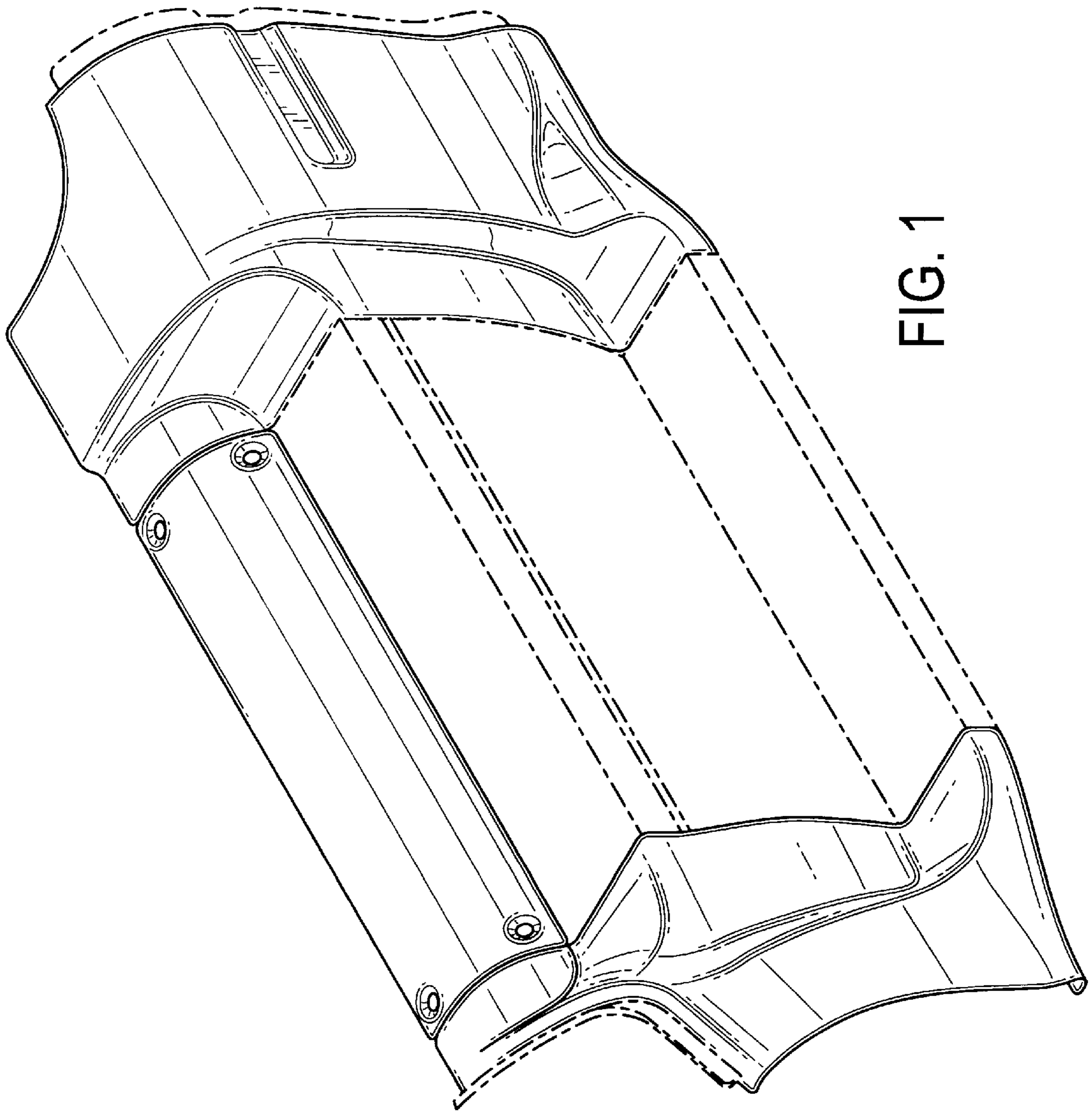

FIG. 1

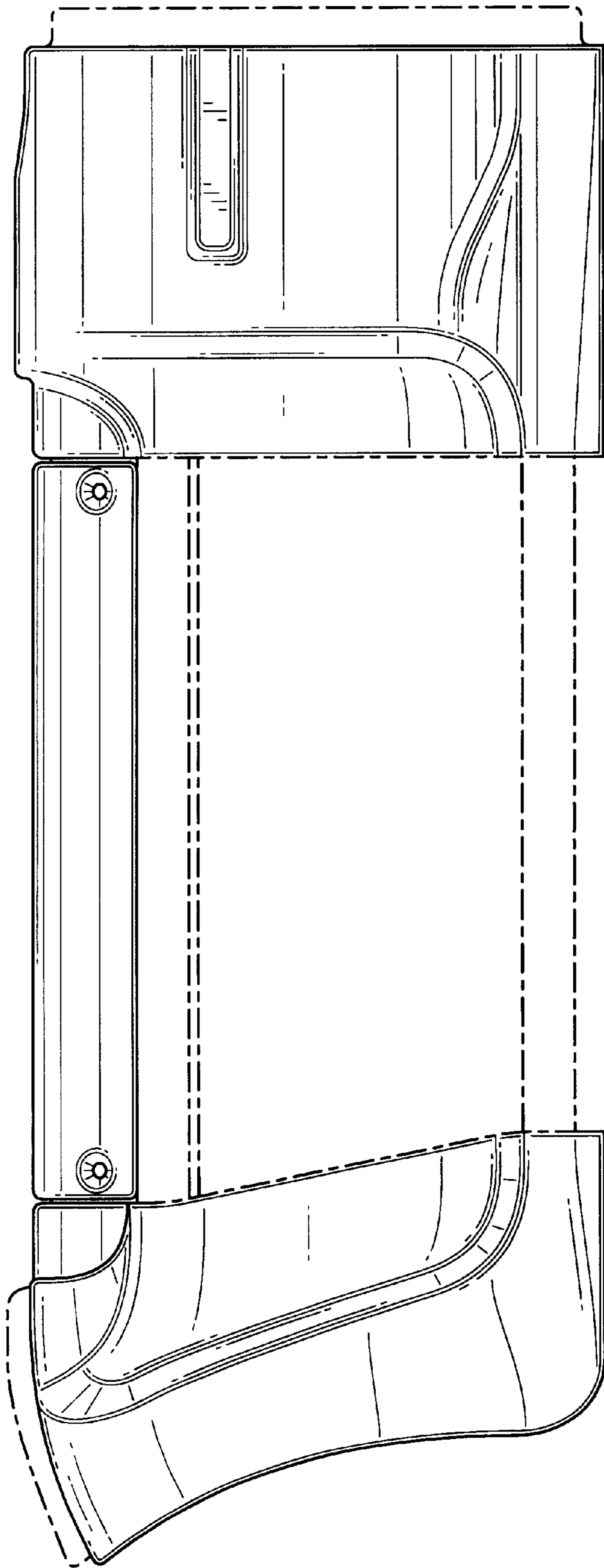

FIG. 2

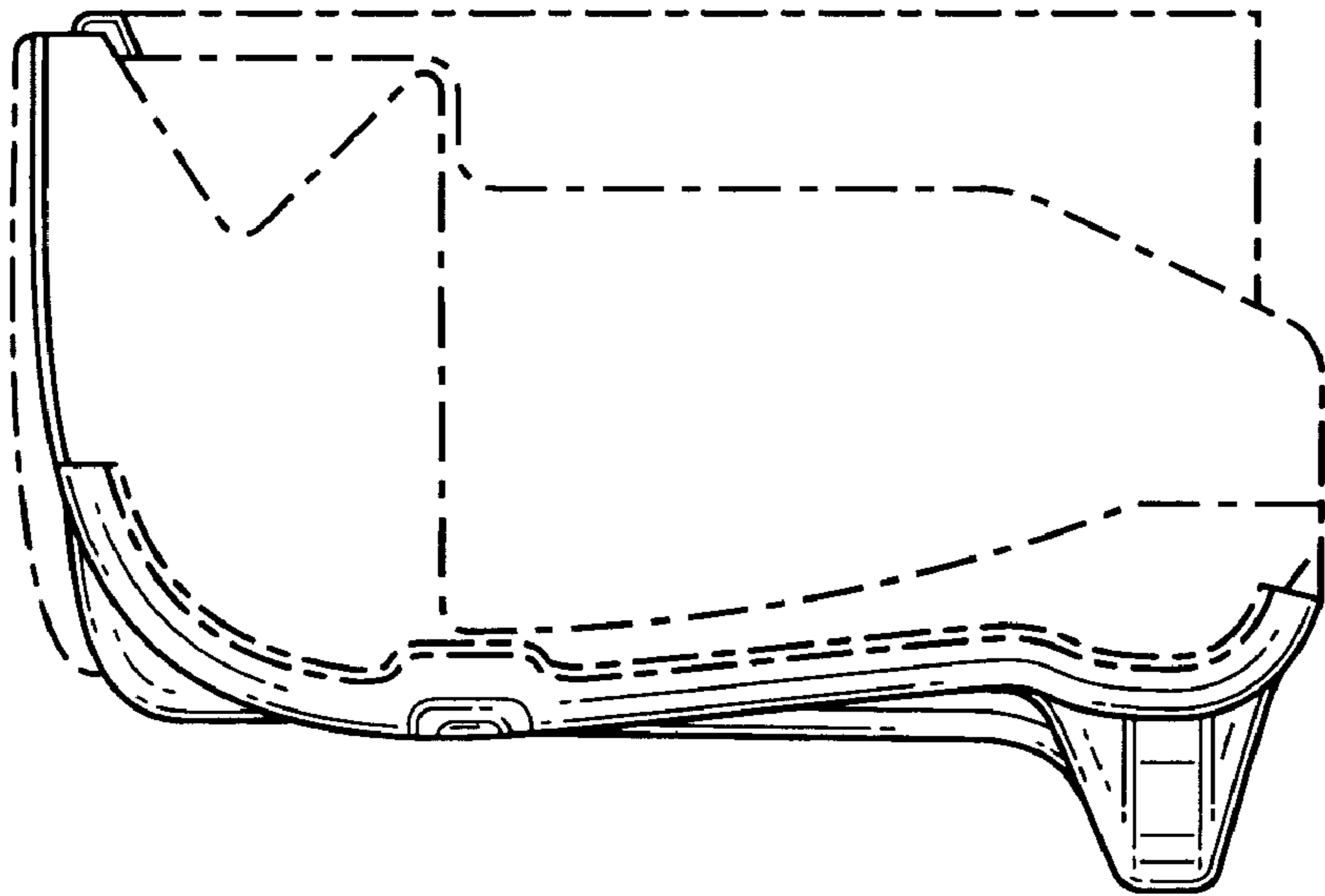

FIG. 3

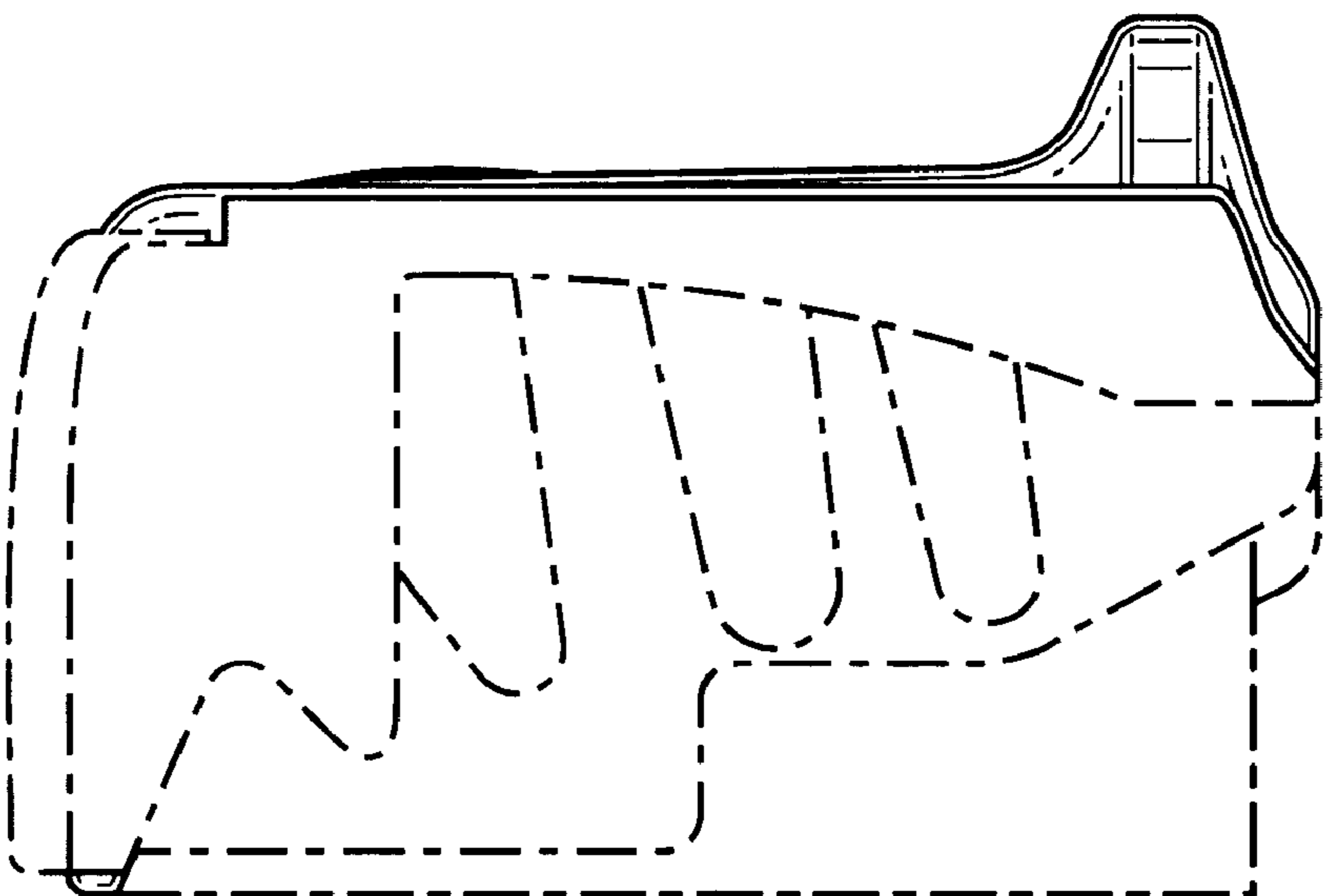

FIG. 4

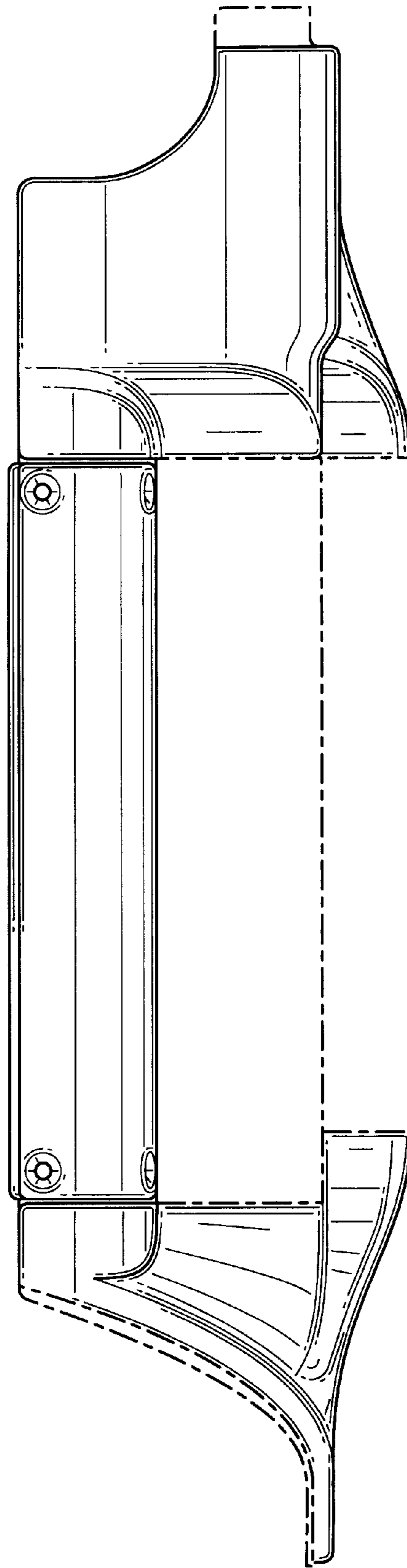

FIG. 5



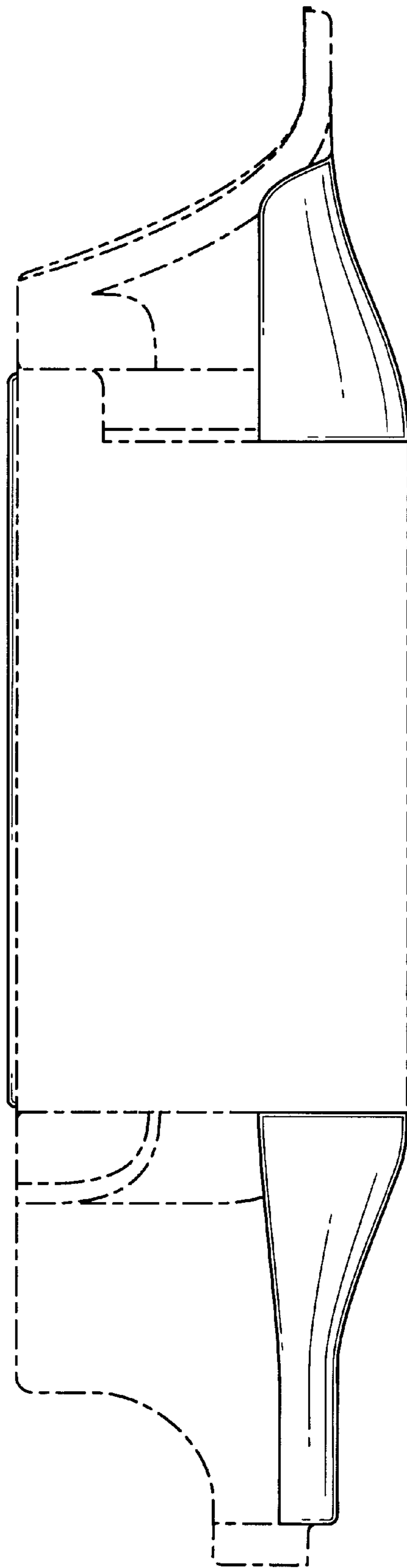

FIG. 6

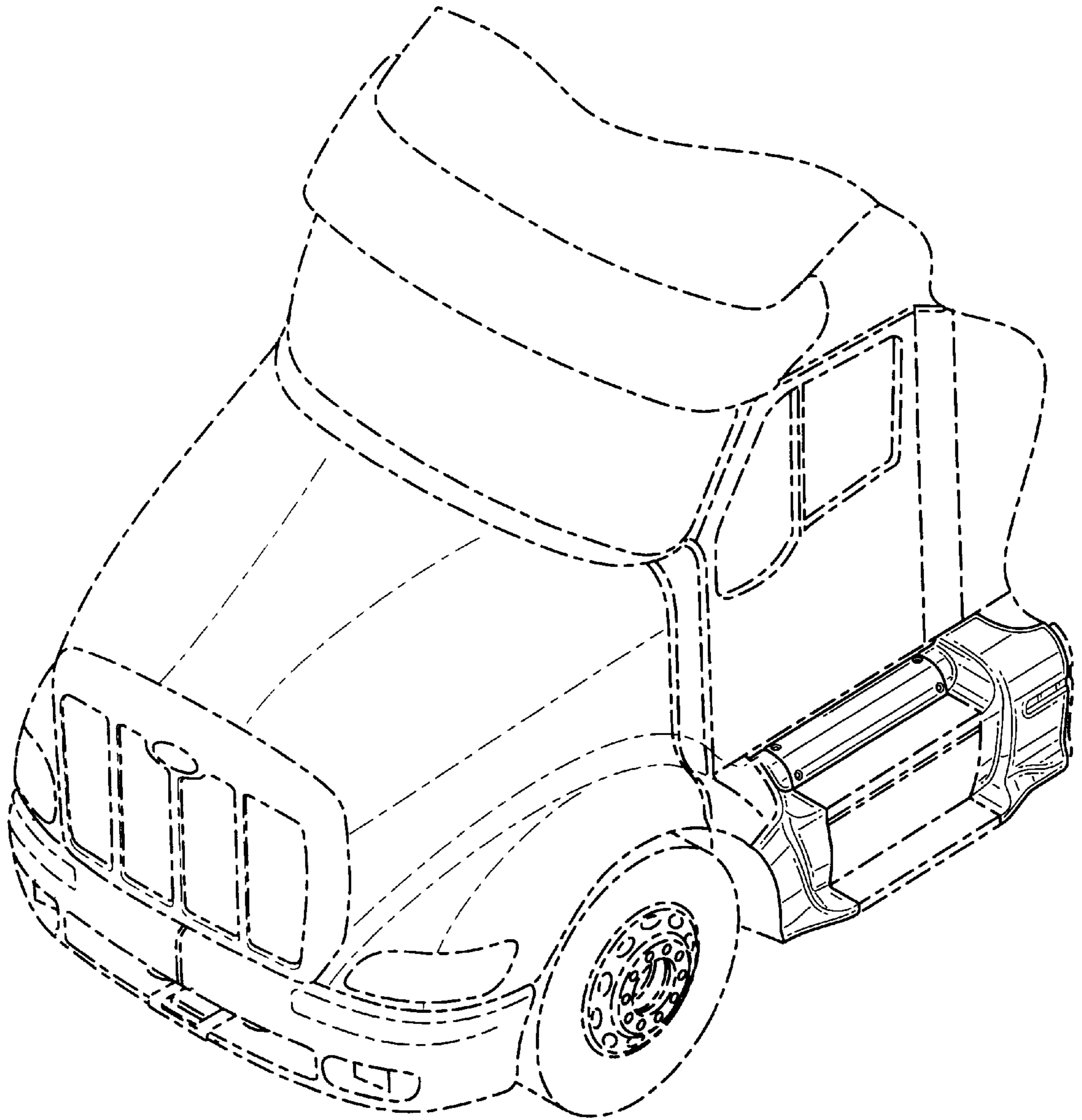

FIG. 7

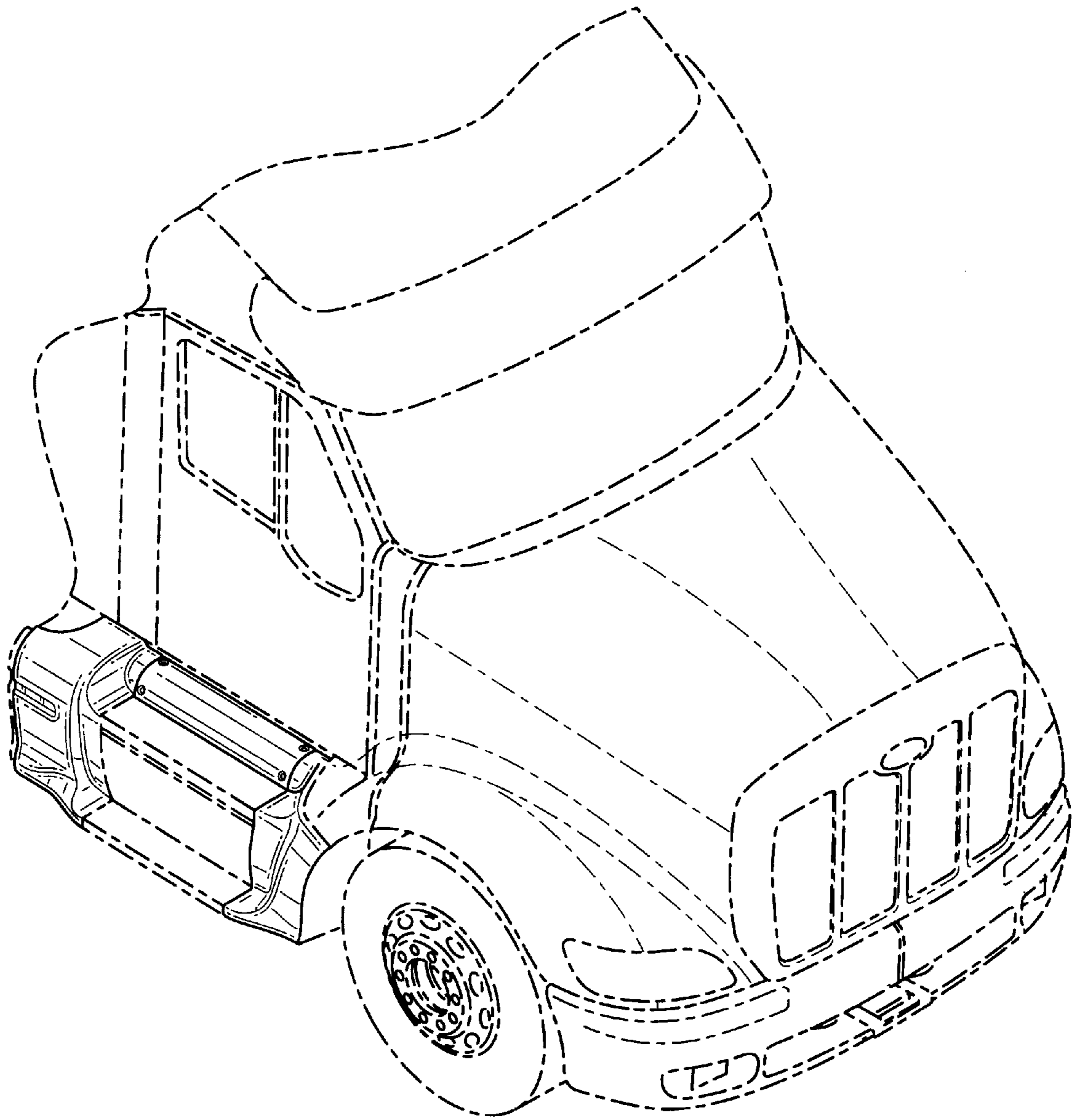

FIG. 8