



US00D433870S

United States Patent [19]
Auclair, Jr.

[11] **Patent Number: Des. 433,870**

[45] **Date of Patent: ** Nov. 21, 2000**

[54] **HOME DISPOSAL DE-CLOGGER**

[76] Inventor: **Norman G Auclair, Jr.**, 251 Mendon Rd., North Attleboro, Mass. 02760

[**] Term: **14 Years**

[21] Appl. No.: **29/116,685**

[22] Filed: **Jan. 7, 2000**

[51] **LOC (7) Cl.** **31-00**

[52] **U.S. Cl.** **D7/375; D8/20**

[58] **Field of Search** **D7/375, 414; D8/20; 241/46.014; 81/176.15, 176.1, 436, 488**

[56] **References Cited**

U.S. PATENT DOCUMENTS

2,803,981 8/1957 Stoecker 81/176.15
5,685,209 11/1997 Fiedler 81/436

Primary Examiner—Mitchell Siegel

[57] **CLAIM**

The ornamental design for a home disposal de-clogger, as shown and described.

DESCRIPTION

FIG. 1 is a front elevational view of the home disposal de-clogger of the present invention;

FIG. 2 is a rear elevational view of the home disposal de-clogger of FIG. 1;

FIG. 3 is a left side elevational view of the home disposal de-clogger of FIG. 1;

FIG. 4 is a right side elevational view of the home disposal de-clogger of FIG. 1;

FIG. 5 is a top plan view of the home disposal de-clogger of FIG. 1; and,

FIG. 6 is a bottom plan view of the home disposal de-clogger of FIG. 1.

1 Claim, 4 Drawing Sheets

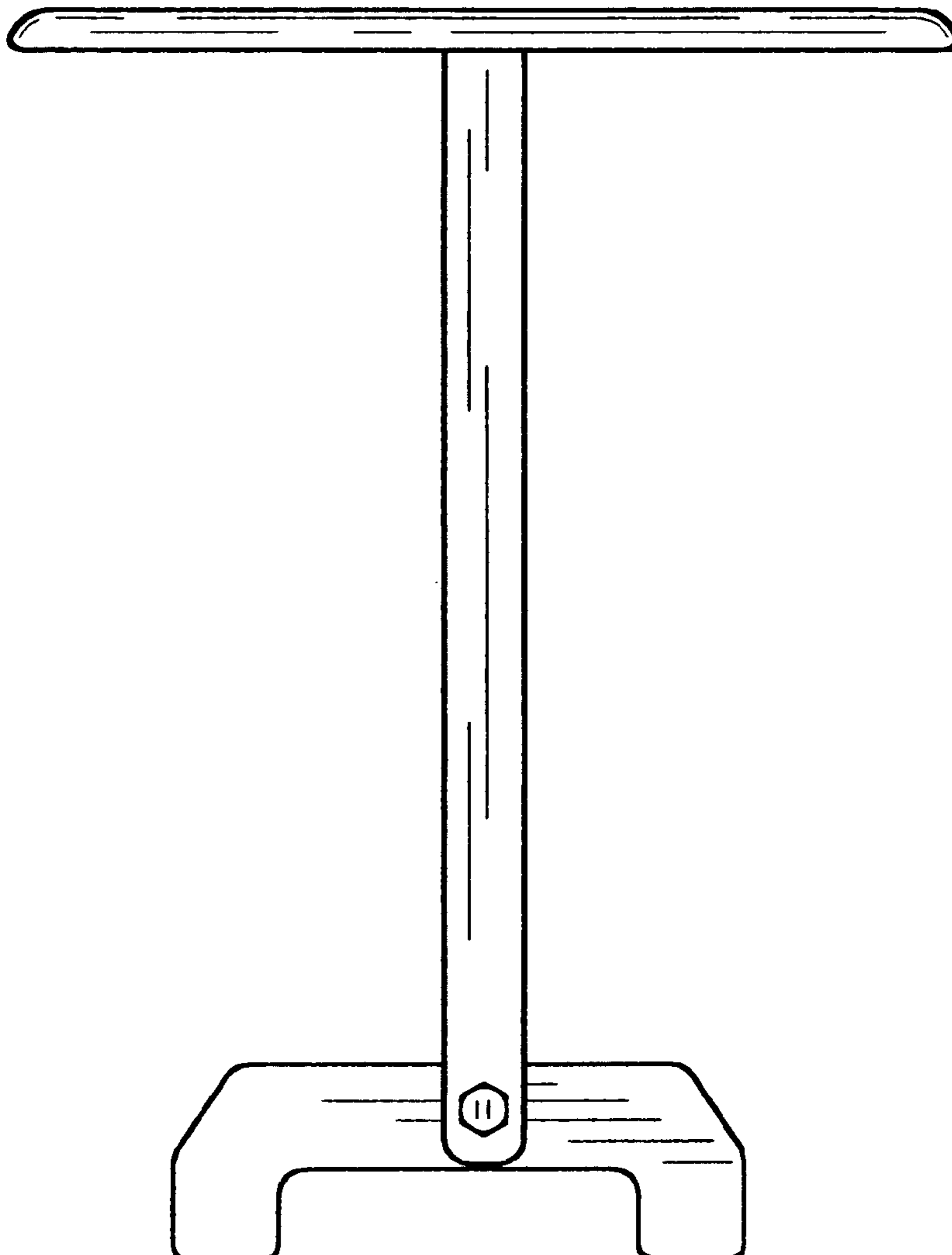

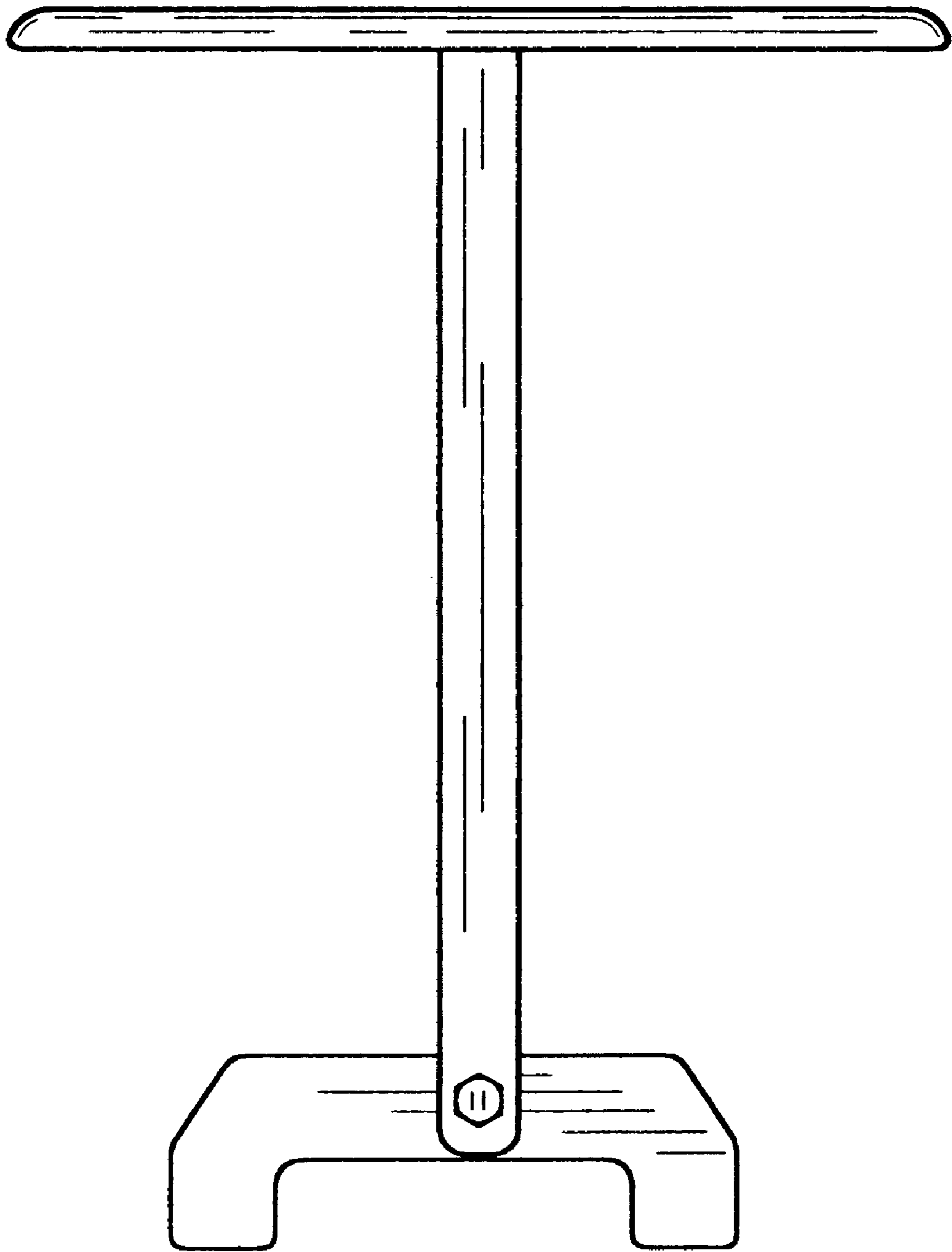

Fig. 1

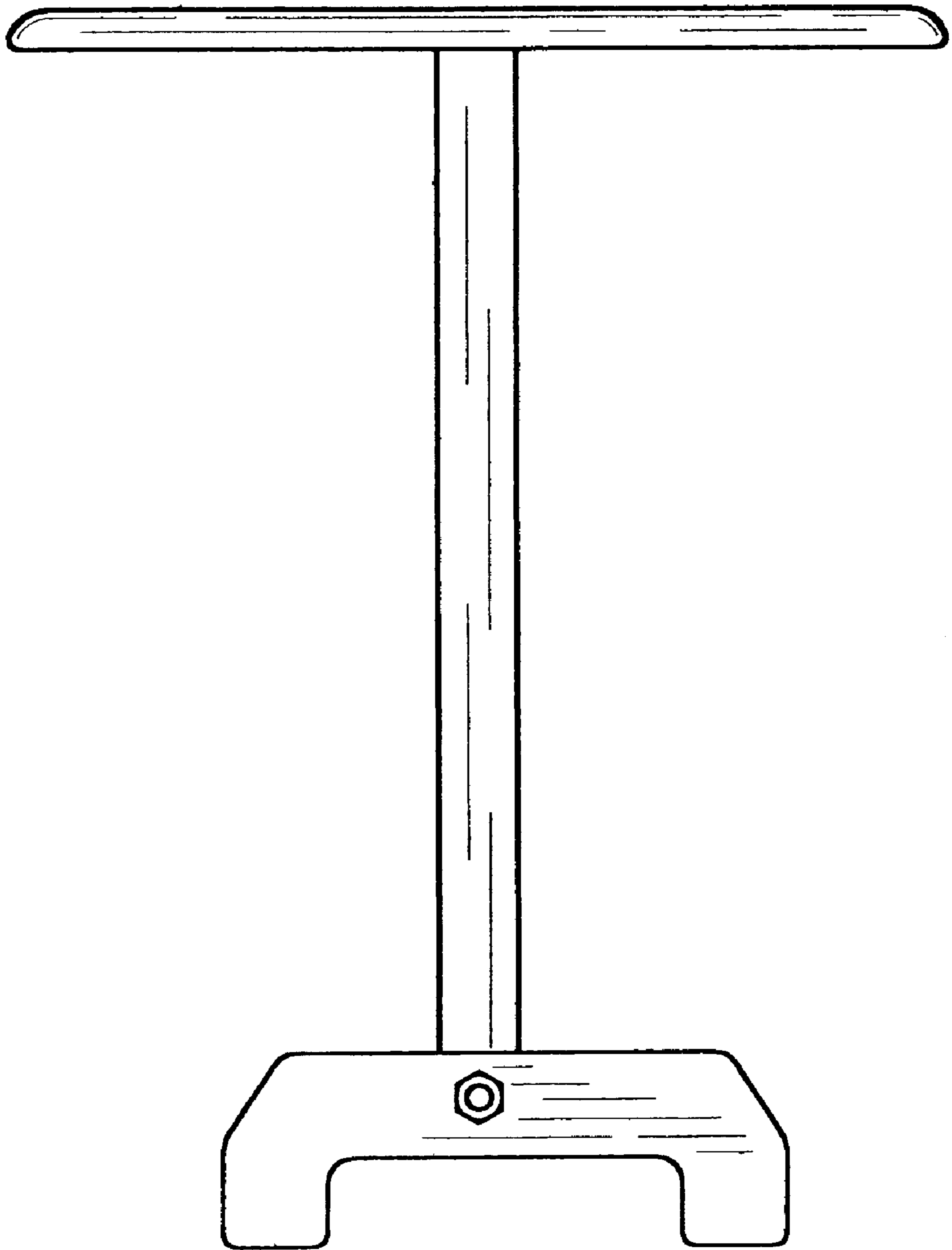

Fig. 2

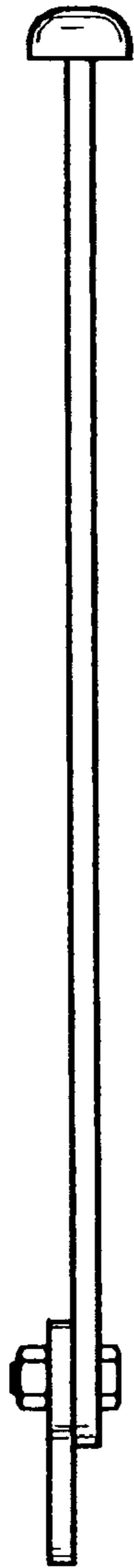

Fig. 3

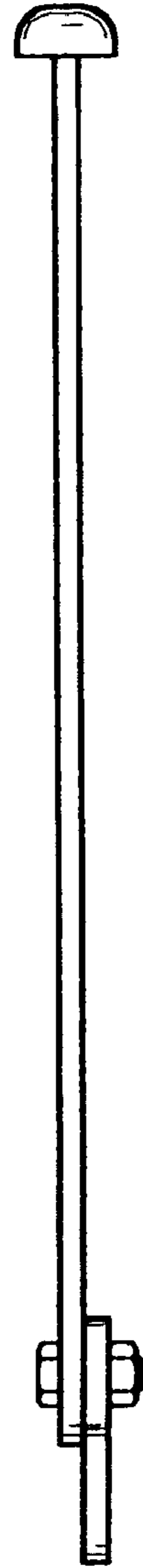

Fig. 4

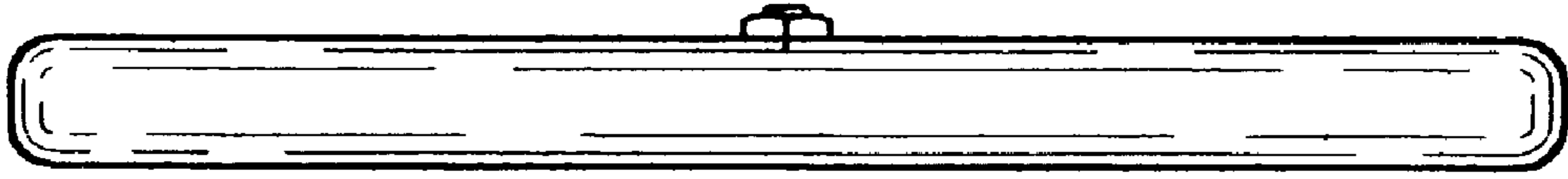

Fig. 5

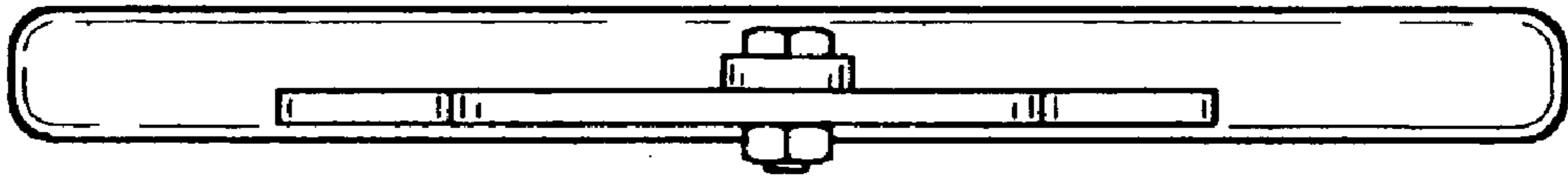

Fig. 6