



US00D433810S

United States Patent [19]

[11] Patent Number: **Des. 433,810**

Kellogg et al.

[45] Date of Patent: **** Nov. 21, 2000**

[54] **MULTIPLE COMPARTMENT CONTAINER**

[75] Inventors: **Michael S. Kellogg**, Oconomowoc;
Dean B. Krotts, Milwaukee, both of
Wis.

[73] Assignee: **Bajer Design & Marketing, Inc.**,
Waukesha, Wis.

[**] Term: **14 Years**

[21] Appl. No.: **29/098,963**

[22] Filed: **Jan. 8, 1999**

[51] **LOC (7) Cl.** **03-01**

[52] **U.S. Cl.** **D3/306**

[58] **Field of Search** D3/304-315; 220/485,
220/486, 487, 9.1, 9.2, 9.3; 383/4

[56] **References Cited**

U.S. PATENT DOCUMENTS

216,227	6/1879	Sedgwick .	
D. 315,432	3/1991	Smith .	
338,892	3/1886	Walker .	
344,340	6/1886	Barow .	
356,301	1/1887	Belknap .	
D. 406,423	3/1999	Kellogg et al. .	
D. 419,302	1/2000	Hardy et al.	D3/306
1,135,892	4/1915	Grosenbeck .	
1,155,475	10/1915	Fay .	
1,180,574	4/1916	Despot .	
1,538,260	5/1925	Street et al. .	
1,581,888	4/1926	Thomas .	
1,691,904	11/1928	Gamble .	
1,979,978	11/1934	Marten .	
1,994,235	3/1935	Solomon .	
1,999,424	4/1935	Seitz .	
2,182,932	12/1939	Sanford .	
2,269,574	1/1942	Benenfeld .	
2,298,786	10/1942	Dubofsky et al. .	
2,575,893	11/1951	Seaman .	
2,625,973	1/1953	Weldon et al. .	
2,710,084	6/1955	Braverman .	
2,746,582	5/1956	Cart .	
2,778,560	1/1957	Pfeiffer .	
2,913,029	11/1959	Paton	220/9.3

3,233,644	2/1966	Bono .	
3,373,925	3/1968	Gatward .	
3,635,368	1/1972	Winsor	220/9.3
3,675,667	7/1972	Miller .	
3,696,850	10/1972	Rosenblum .	
3,935,958	2/1976	Frangos	220/9.2
3,960,161	6/1976	Norman .	
3,990,463	11/1976	Norman .	
4,055,239	10/1977	Weiner .	
4,697,357	10/1987	Van Vliet .	
4,784,248	11/1988	Workman .	
4,813,520	3/1989	Lin .	
4,815,784	3/1989	Zheng .	
4,825,892	5/1989	Norman .	
4,858,634	8/1989	McLeese .	
4,862,602	9/1989	Krill .	

(List continued on next page.)

Primary Examiner—Louis S. Zarfaz
Assistant Examiner—Catherine R. Oliver
Attorney, Agent, or Firm—Ryan Kromholz & Manion, S.C.

[57] **CLAIM**

The ornamental design of multiple compartment container, as shown and described.

DESCRIPTION

FIG. 1 is a perspective view of the multiple compartment container of our design;
FIG. 2 is a bottom plan view of our container;
FIG. 3 is a front elevational view of our container, the rear elevational view being identical thereto;
FIG. 4 is a right elevational view of our container, the left elevational view being identical thereto;
FIG. 5 is a top plan view of our container;
FIG. 6 is a perspective view of a second embodiment of the multiple compartment container of our design;
FIG. 7 is a bottom plan view of our container;
FIG. 8 is a front elevational view of our container, the rear elevational view being identical thereto;
FIG. 9 is a right elevational view of our container, the left elevational view being identical thereto; and,
FIG. 10 is a top plan view of our container.

1 Claim, 4 Drawing Sheets

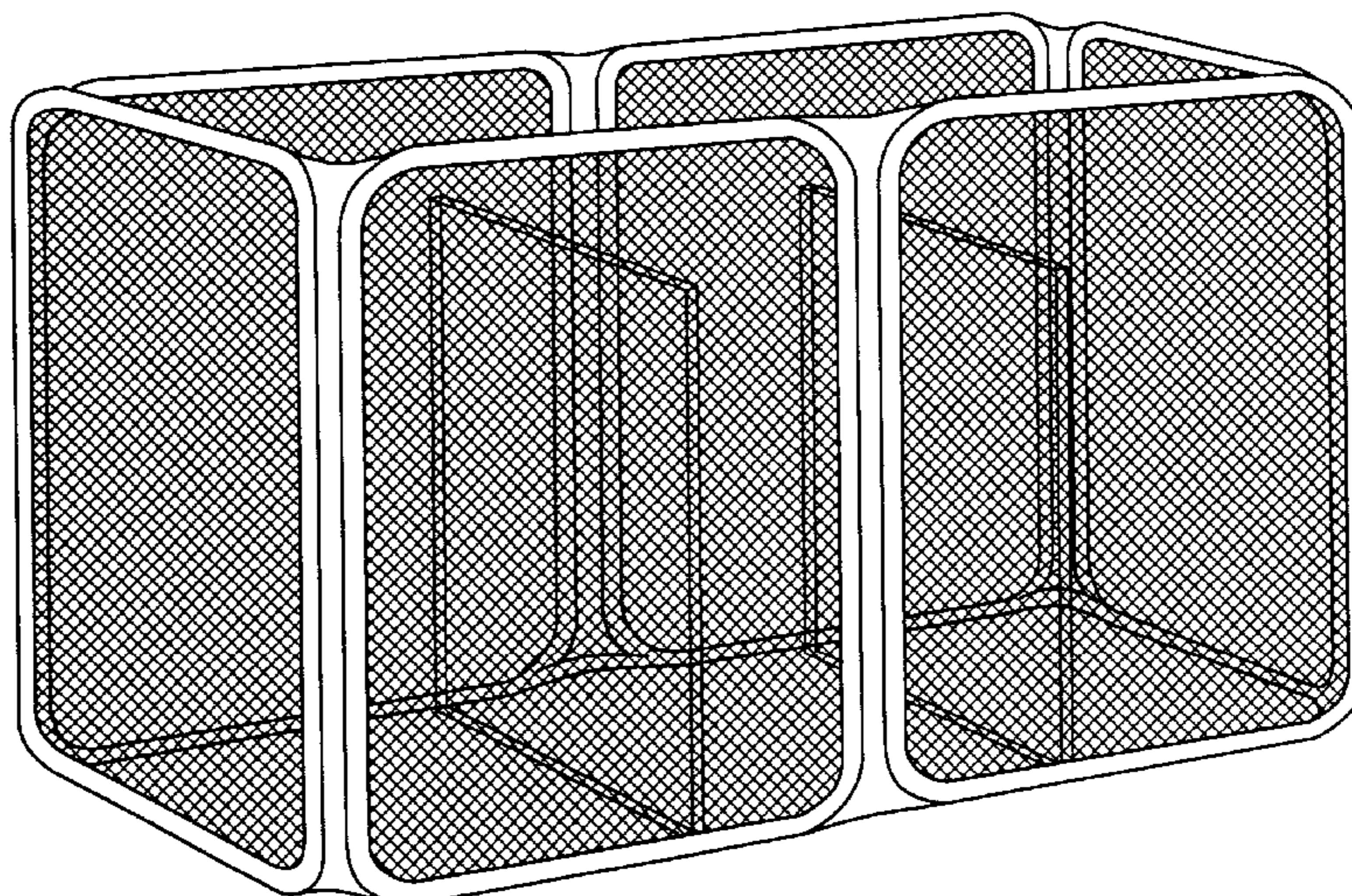

U.S. PATENT DOCUMENTS

4,895,230	1/1990	King .	5,560,385	10/1996	Zheng .
4,951,333	8/1990	Kaiser et al. .	5,664,596	9/1997	Zheng .
4,995,487	2/1991	Plath .	5,664,886	9/1997	Hutchinson .
5,009,189	4/1991	Neff .	5,800,067	9/1998	Easter .
5,024,262	6/1991	Huang .	5,816,279	10/1998	Zheng .
5,038,812	8/1991	Norman .	5,901,926	5/1999	Zheng .
5,072,828	12/1991	Irvine .	5,910,038	6/1999	Zheng .
5,090,588	2/1992	Van Romer et al. .	5,910,058	6/1999	Zheng .
5,116,138	5/1992	Maesenti et al. .	5,938,496	8/1999	Zheng .
5,213,147	5/1993	Zheng .	5,941,265	8/1999	Zheng .
5,358,440	10/1994	Zheng .	5,975,101	11/1999	Zheng .
			6,006,772	12/1999	Zheng .

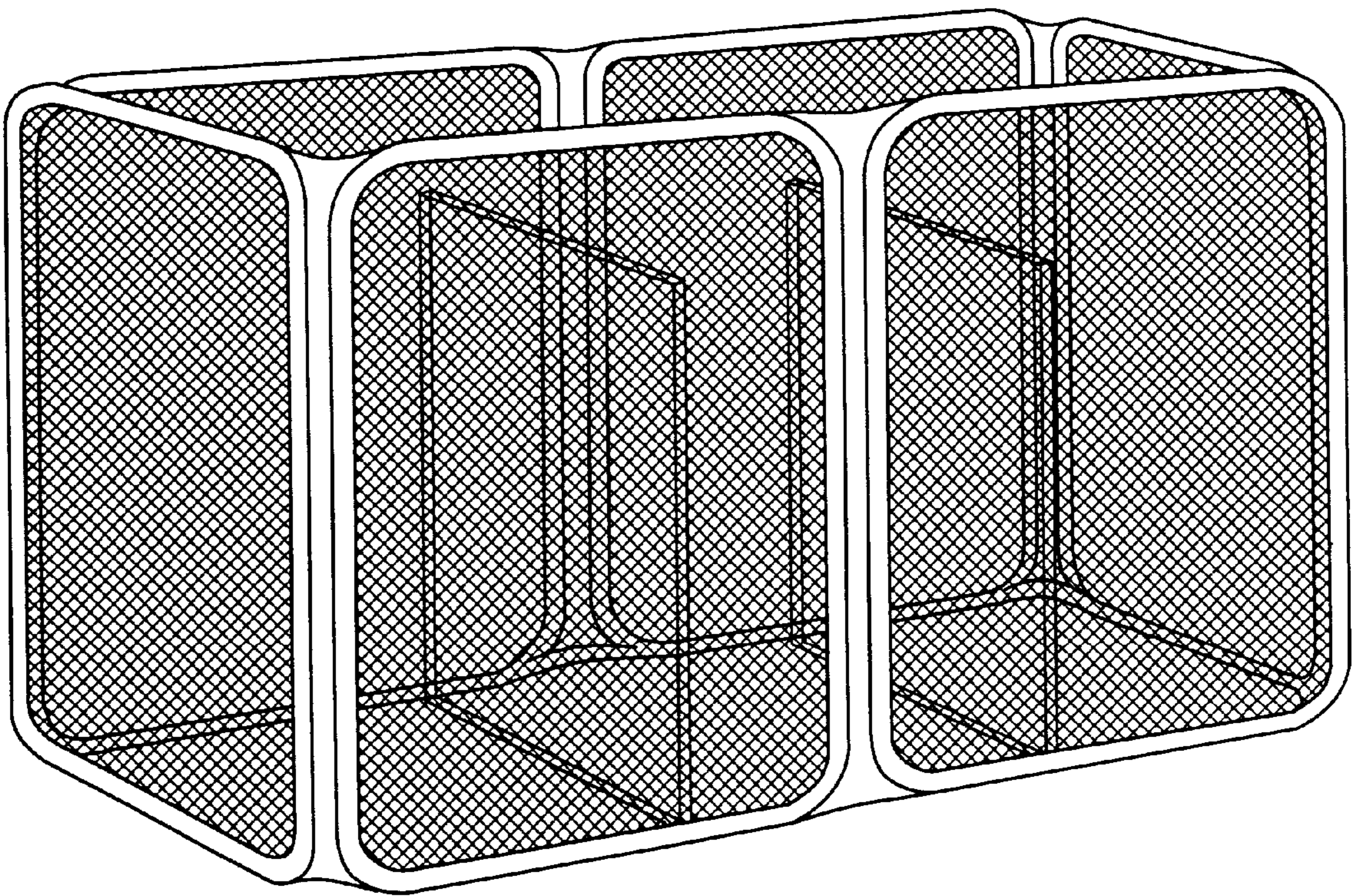

FIG. 1

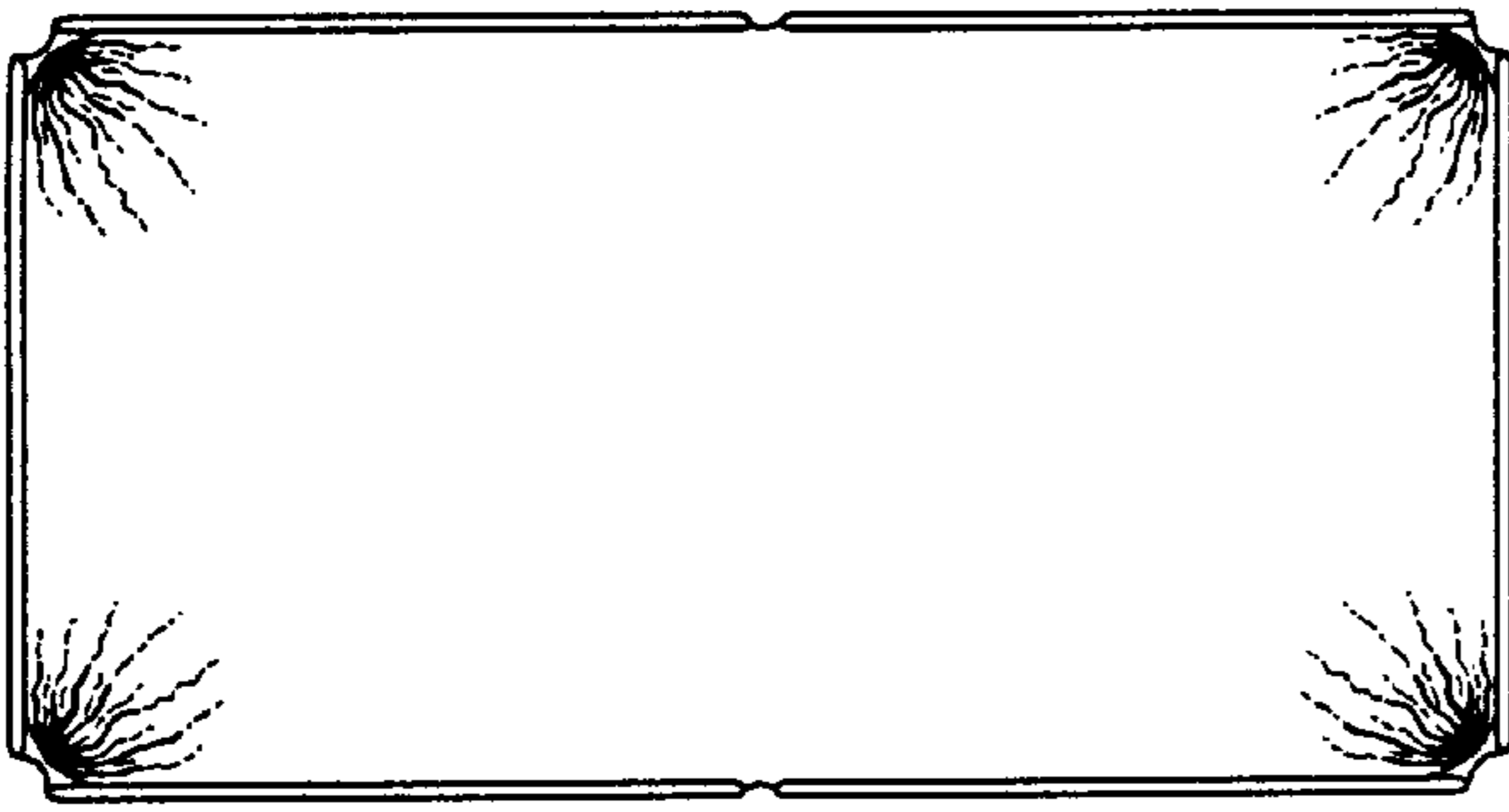

FIG. 2

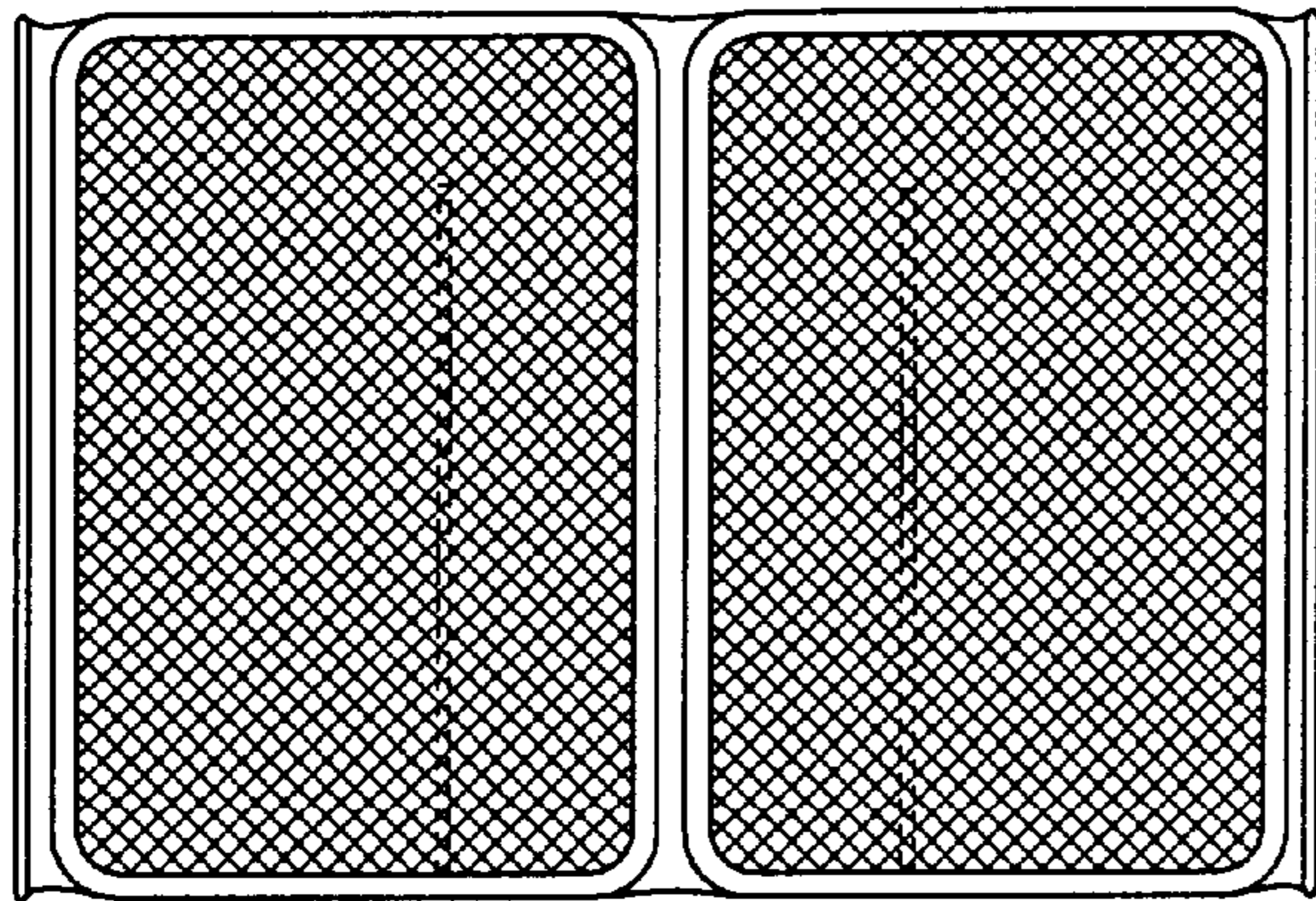

FIG. 3

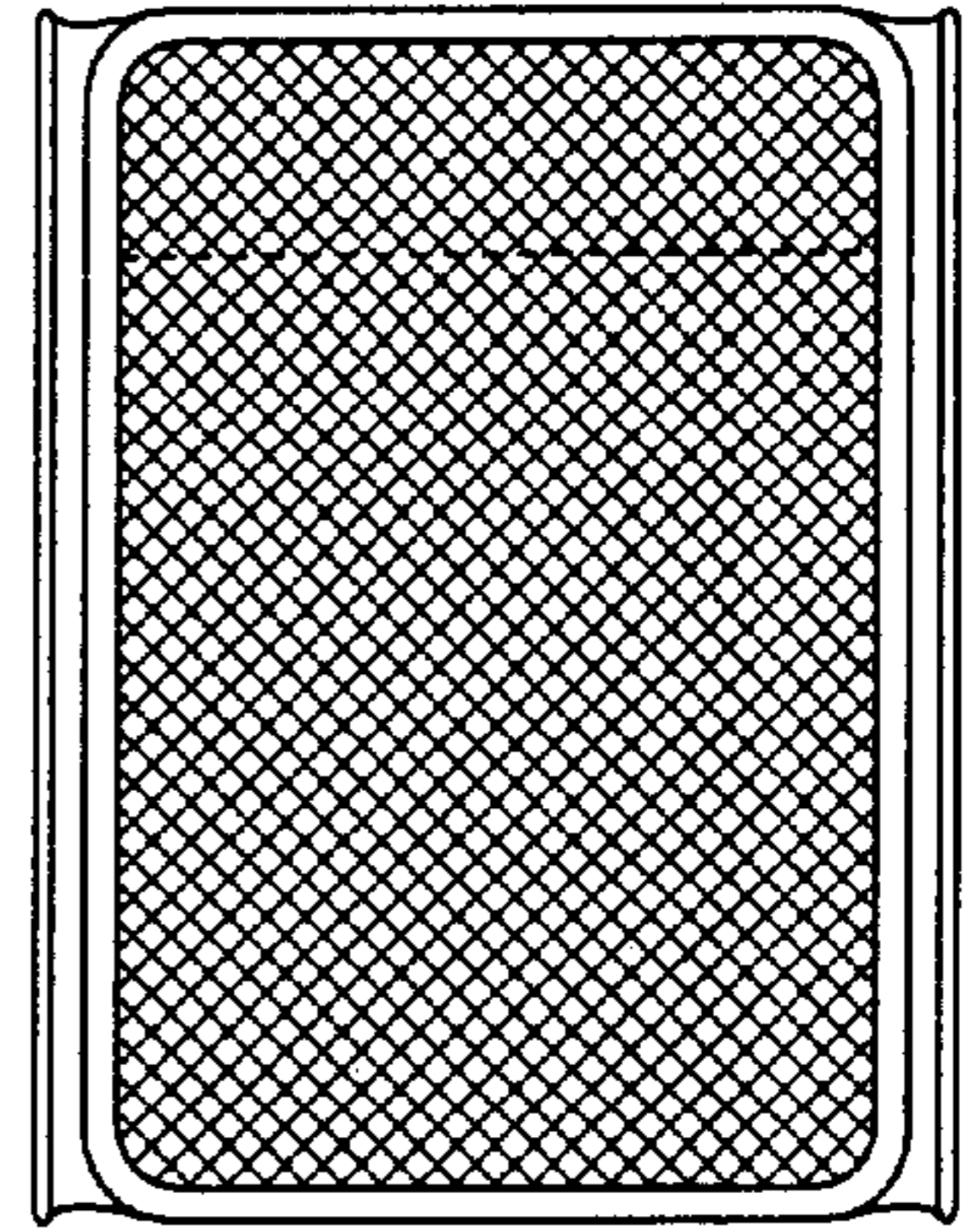

FIG. 4

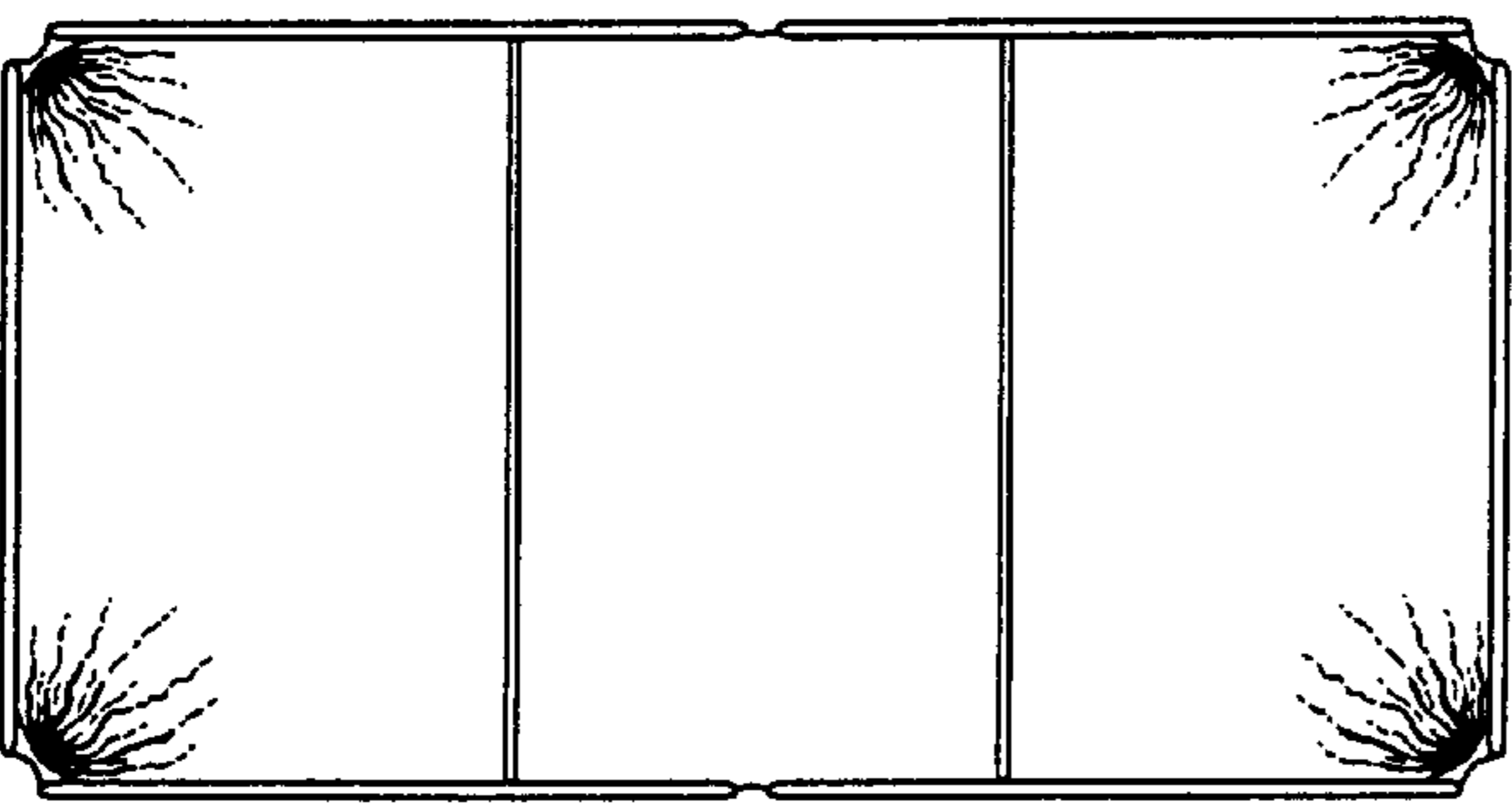

FIG. 5

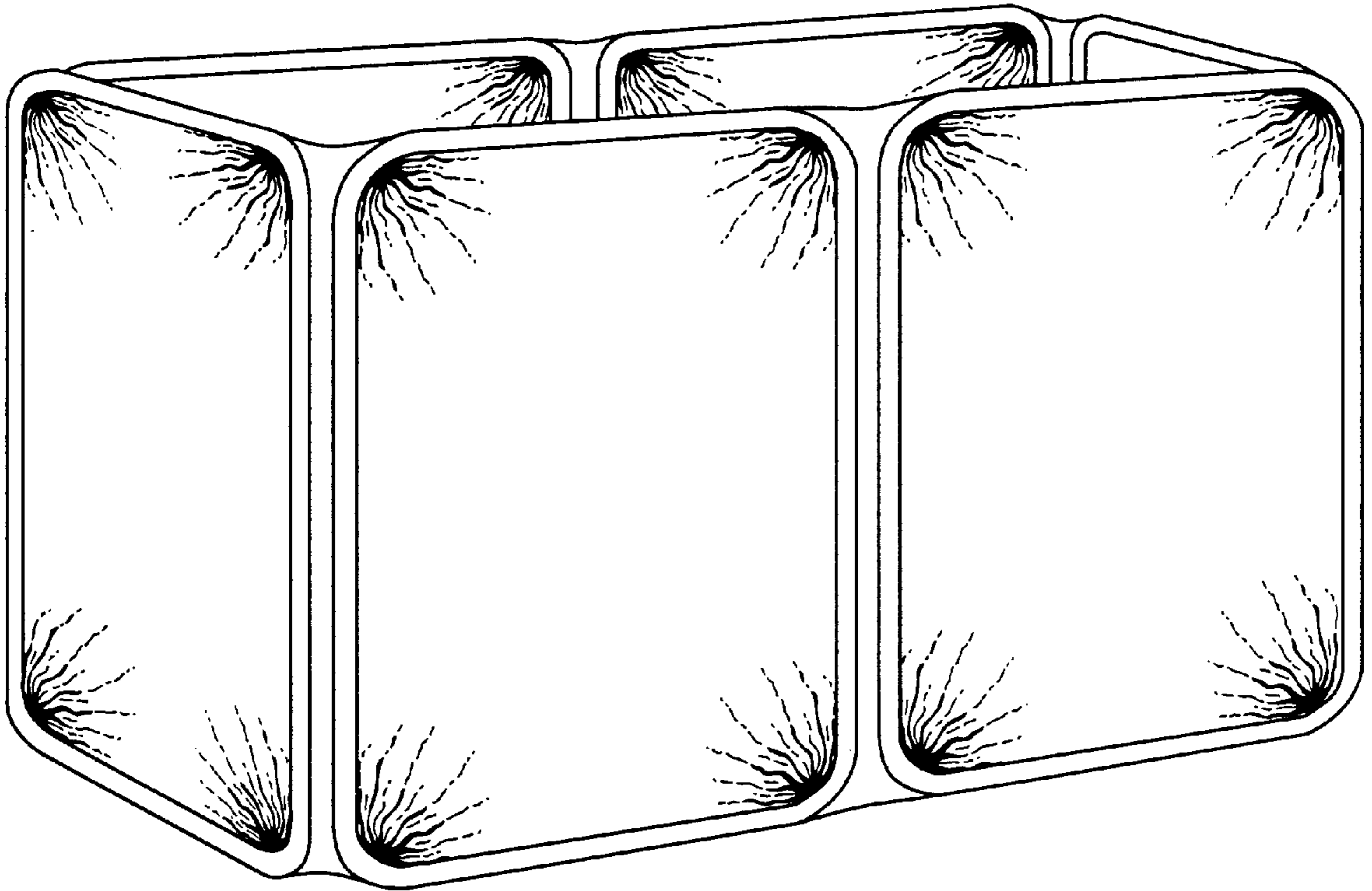

FIG. 6

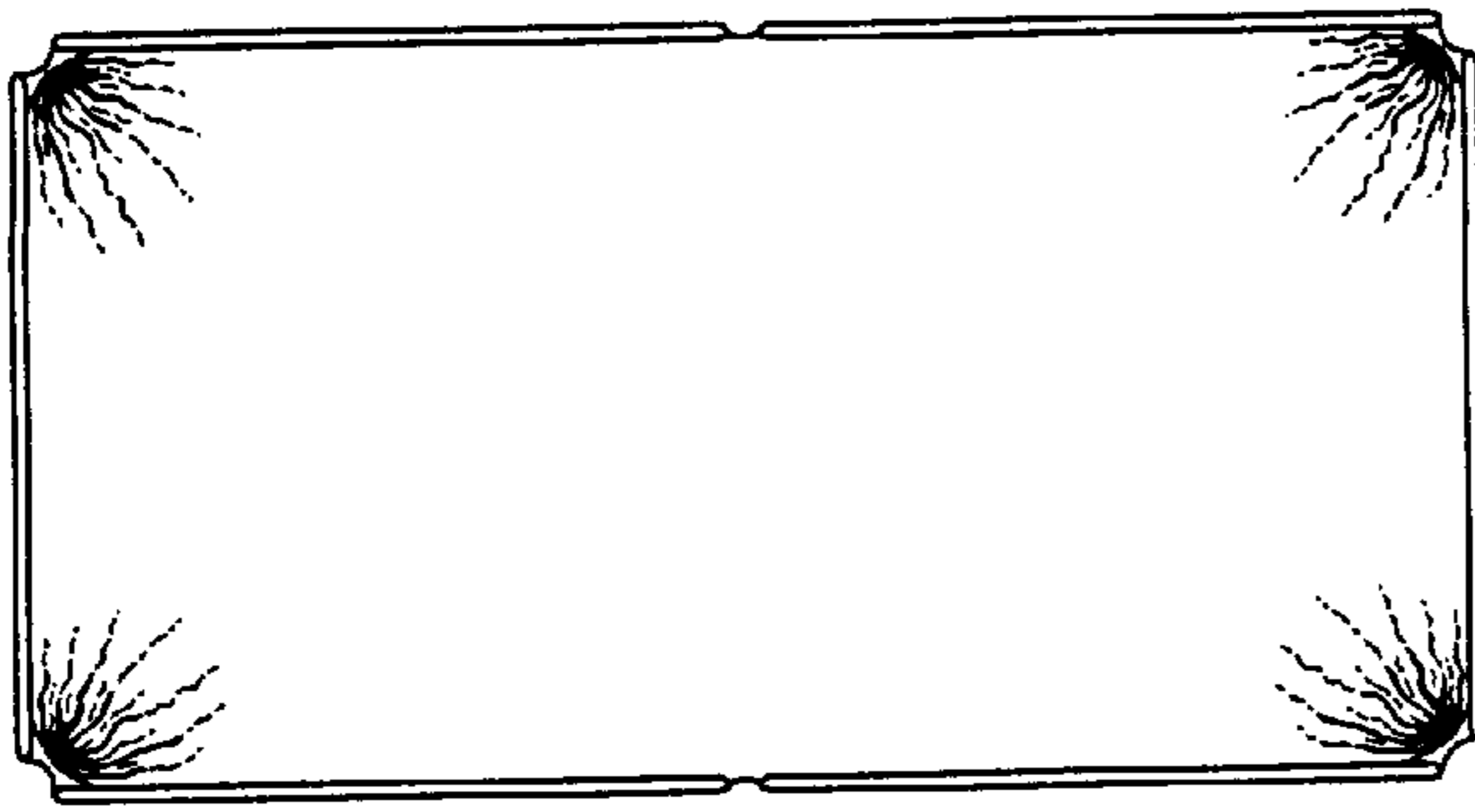

FIG. 7

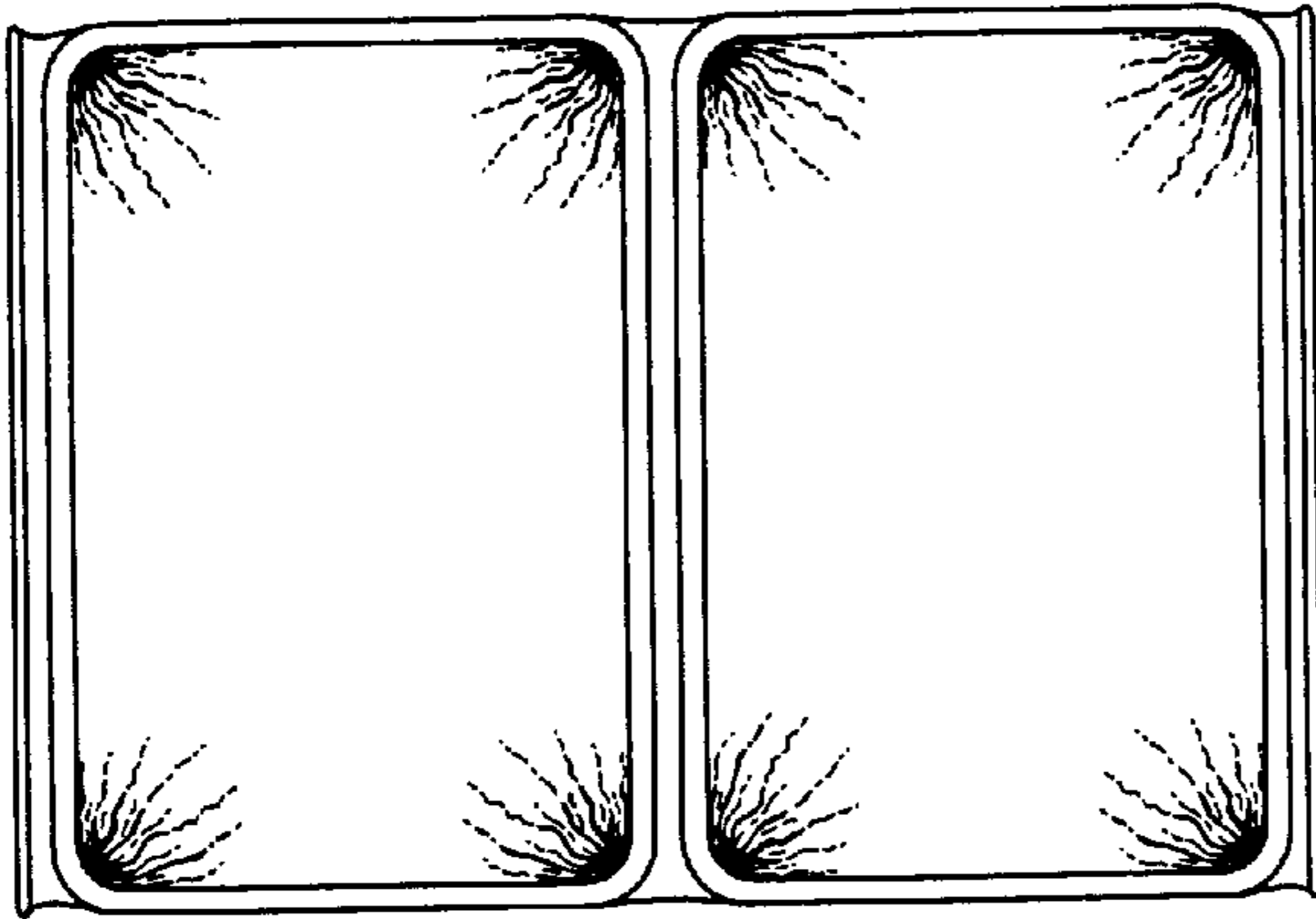

FIG. 8

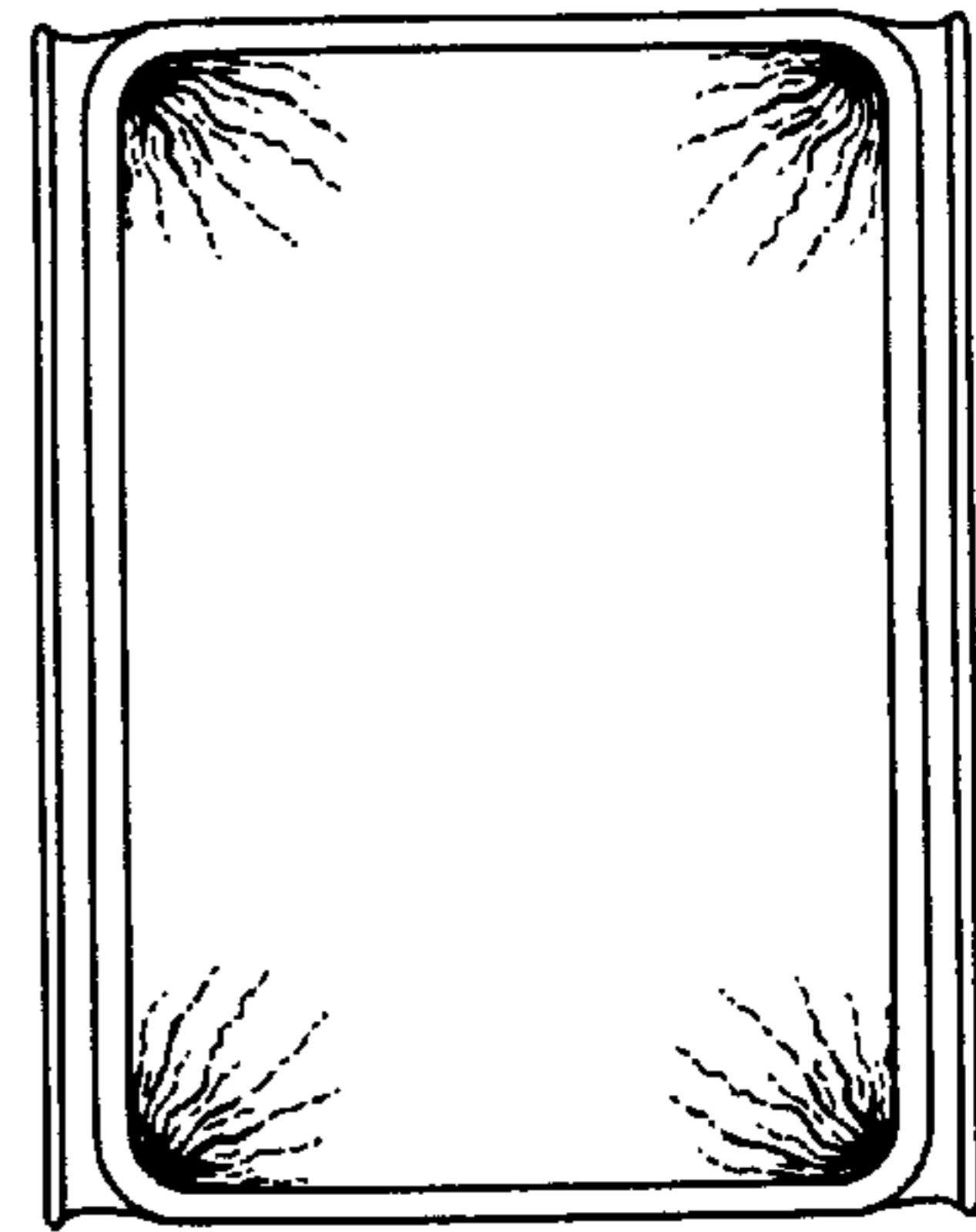

FIG. 9

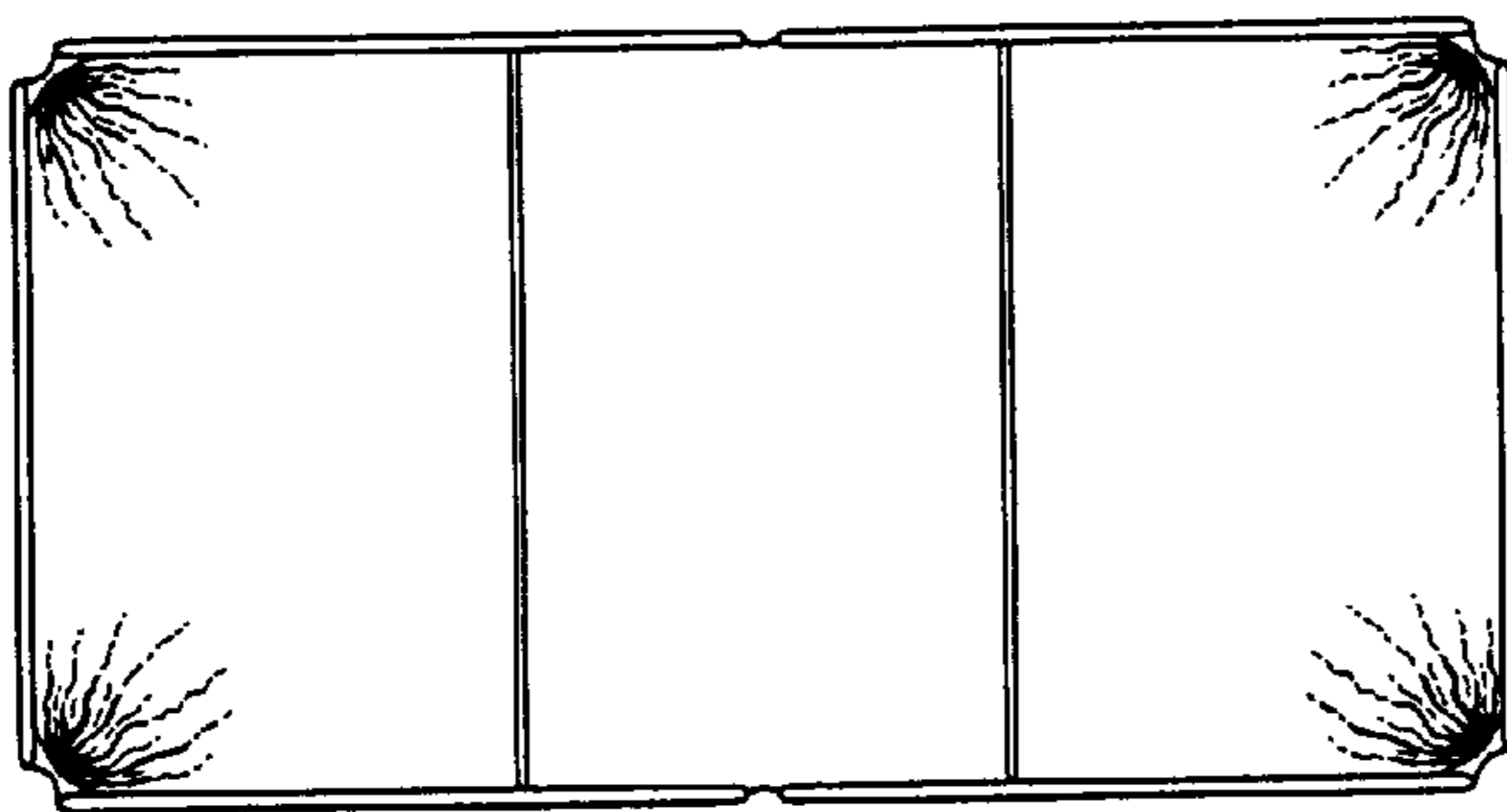

FIG. 10