



US00D433692S

United States Patent [19]
Fort et al.

[11] **Patent Number: Des. 433,692**
[45] **Date of Patent: ** Nov. 14, 2000**

[54] **SWIVABLE NOZZLE FOR DISPENSING ADHESIVES AND SEALANTS**

[75] Inventors: **Wesley C. Fort**, Norcross; **John M. Raterman**, Atlanta, both of Ga.

[73] Assignee: **Nordson Corporation**, Westlake, Ohio

[**] Term: **14 Years**

[21] Appl. No.: **29/113,253**

[22] Filed: **Nov. 2, 1999**

Related U.S. Application Data

[63] Continuation-in-part of application No. 29/108,650, Jul. 30, 1999, and a continuation-in-part of application No. 29/092,589, Aug. 24, 1998, Pat. No. Des. 420,024.

[51] **LOC (7) Cl.** **15-09**

[52] **U.S. Cl.** **D15/144.1**

[58] **Field of Search** D15/144.1, 144.2; 239/11, 71, 536, 602; 425/7; 427/208.2

[56] **References Cited**

U.S. PATENT DOCUMENTS

D. 366,051	1/1996	Lewis et al. .	
3,304,013	2/1967	O'Brian	239/602 X
3,543,332	12/1970	Wagner et al. .	
4,469,248	9/1984	Petrecca .	
5,887,757	3/1999	Jenkins et al. .	

OTHER PUBLICATIONS

Series H-200 Hot Melt Guns, © 1993, 1995, 1997, 1998 Nordson Corporation; Reissued Jun. 1998.
Controlled Fiberization™ Technology; © Nordson Corporation 1994, 1996.

ITW Dynatec EZ Nozzles.
Automatic Extrusion Nozzles; Slautterback Corp., 1997.
Hot Melt Adhesive Dispensing Equipment; Nordson Corporation, 1998.
Precision Nozzles; Nordson Corporation; 1995.

Primary Examiner—Antoine Duval Davis
Attorney, Agent, or Firm—Raymond J. Slattery, III

[57] **CLAIM**

The ornamental design for a swivable nozzle for dispensing adhesives and sealants, as shown and described.

DESCRIPTION

FIG. 1 is a front perspective view of a new design for a swivable nozzle for dispensing adhesives and sealants; FIG. 2 is a rear perspective view; FIG. 3 is a top view; FIG. 4 is a front elevational view; FIG. 5 is a side elevational view, the opposite side view being a mirror image thereof; FIG. 6 is a rear elevational view; FIG. 7 is a bottom view; FIG. 8 is a front elevational view of another embodiment for the nozzle wherein the slot of the front face of the first embodiment has been replaced with a hex opening; FIG. 9 is a front elevational view of a third embodiment for the nozzle wherein the slot of the front face of the first embodiment has been replaced with a cross opening; and, FIG. 10 is a front elevational view of a fourth embodiment for the nozzle wherein the slot of the front face of the first embodiment has been replaced with a rectangular opening.

1 Claim, 2 Drawing Sheets

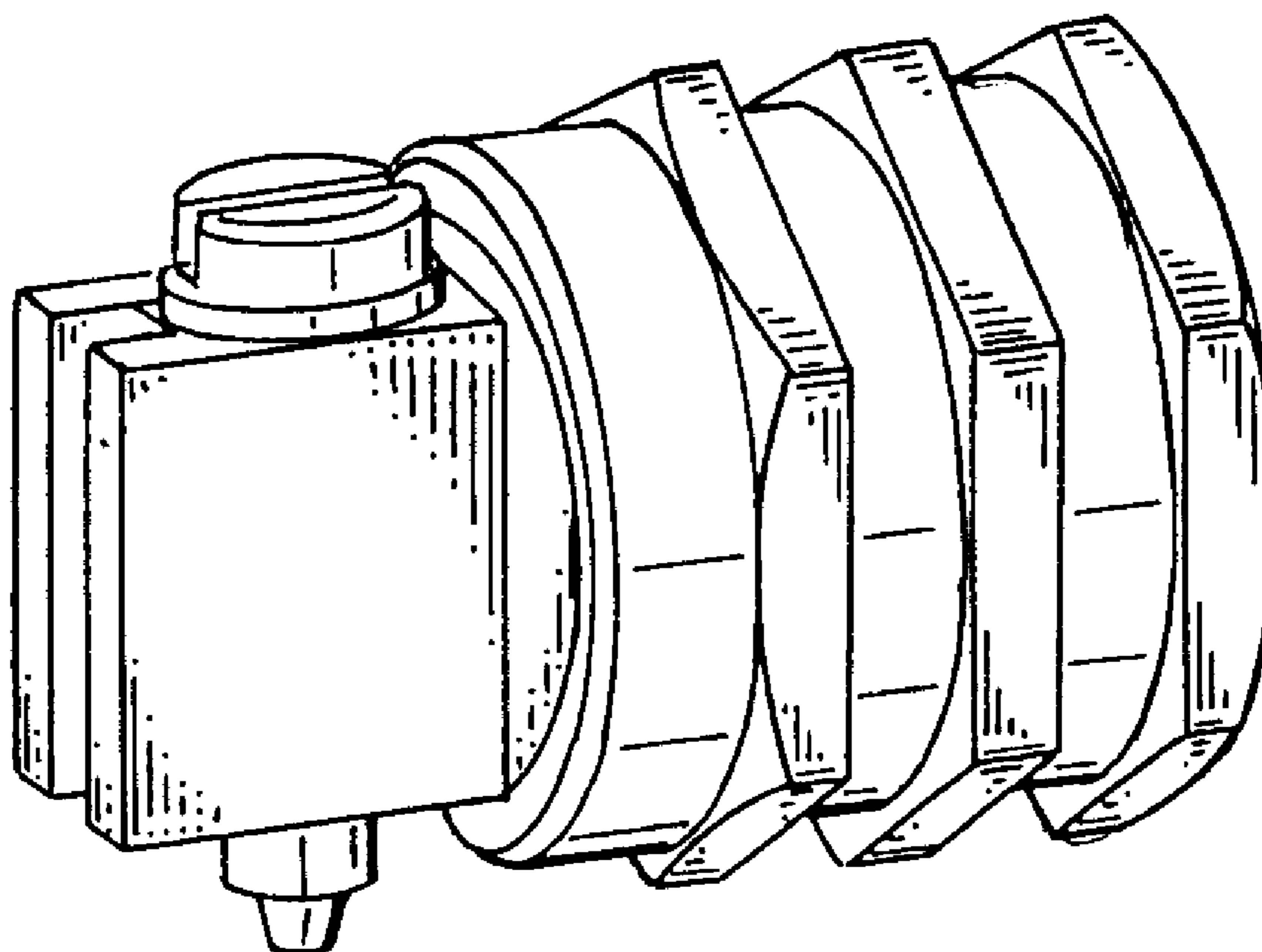

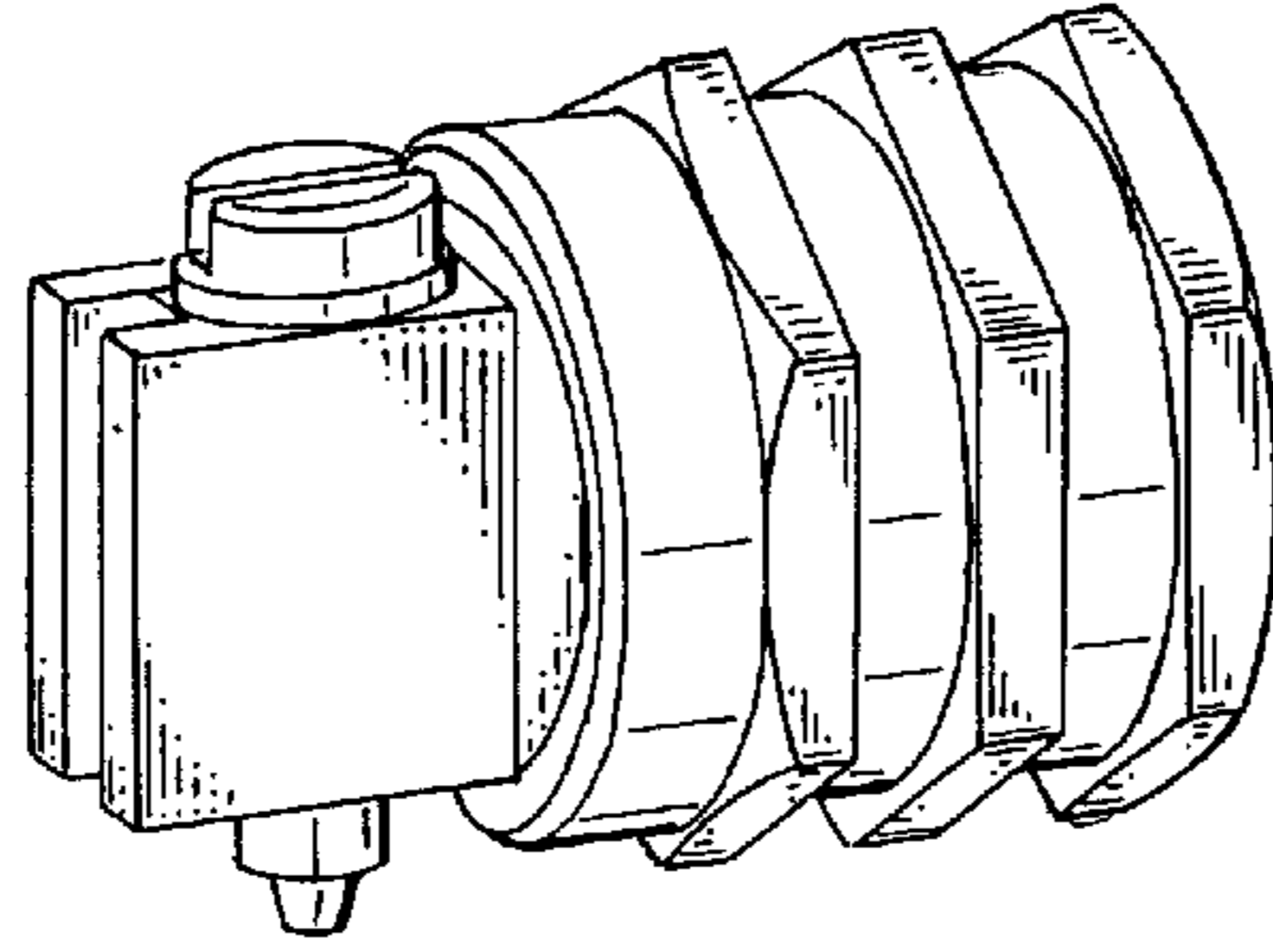

FIG. -1

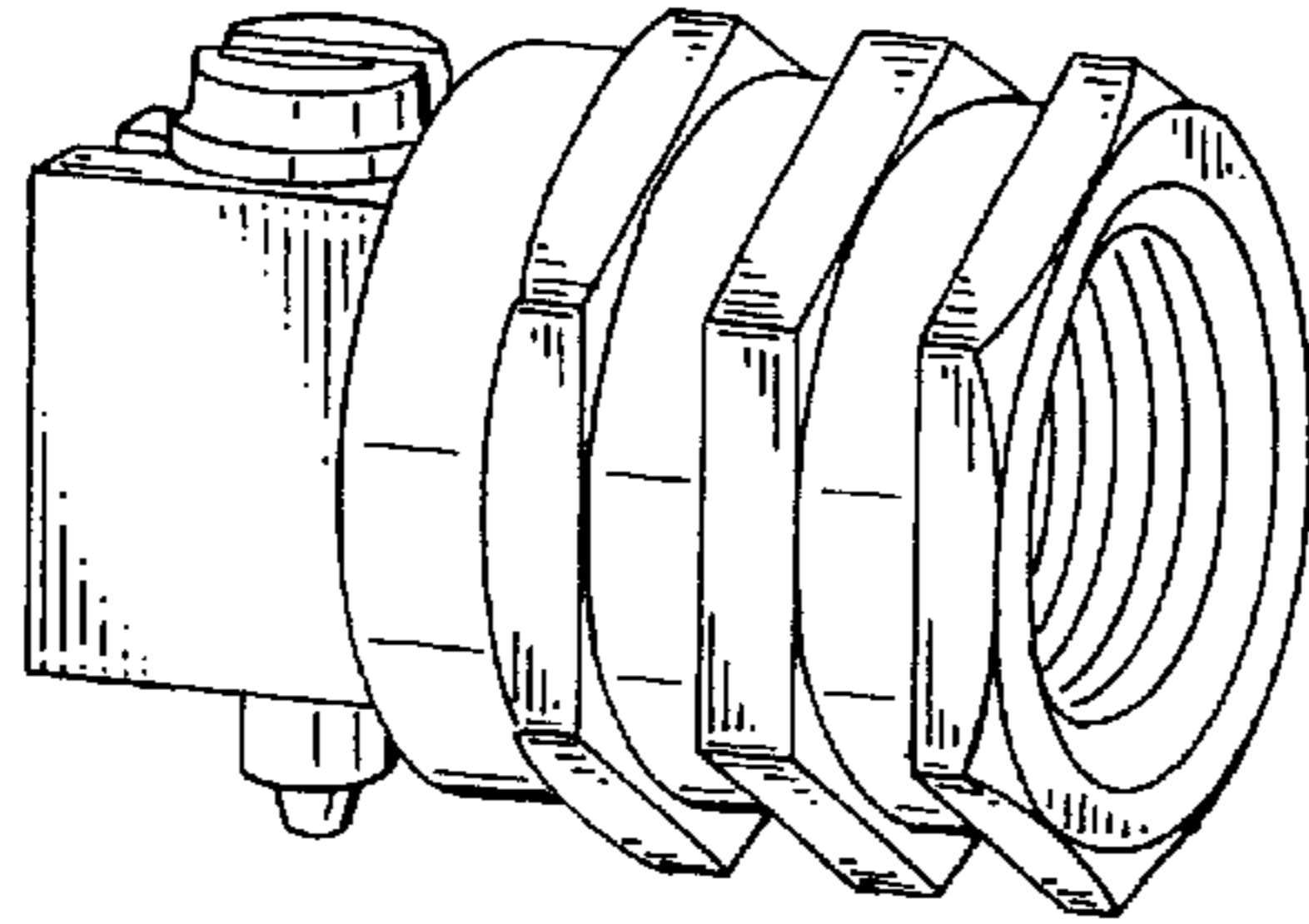

FIG. -2

FIG. -3

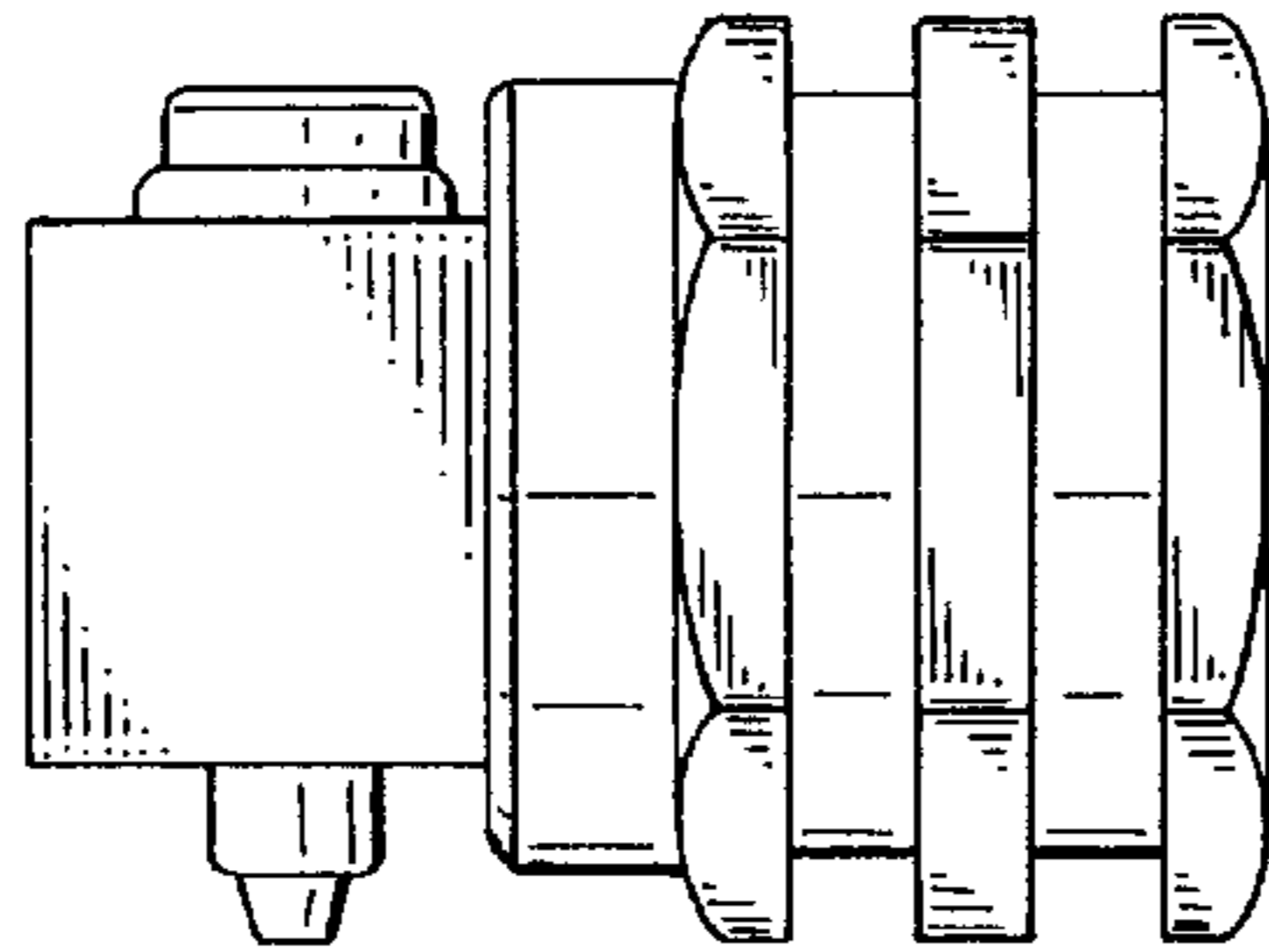

FIG. -5

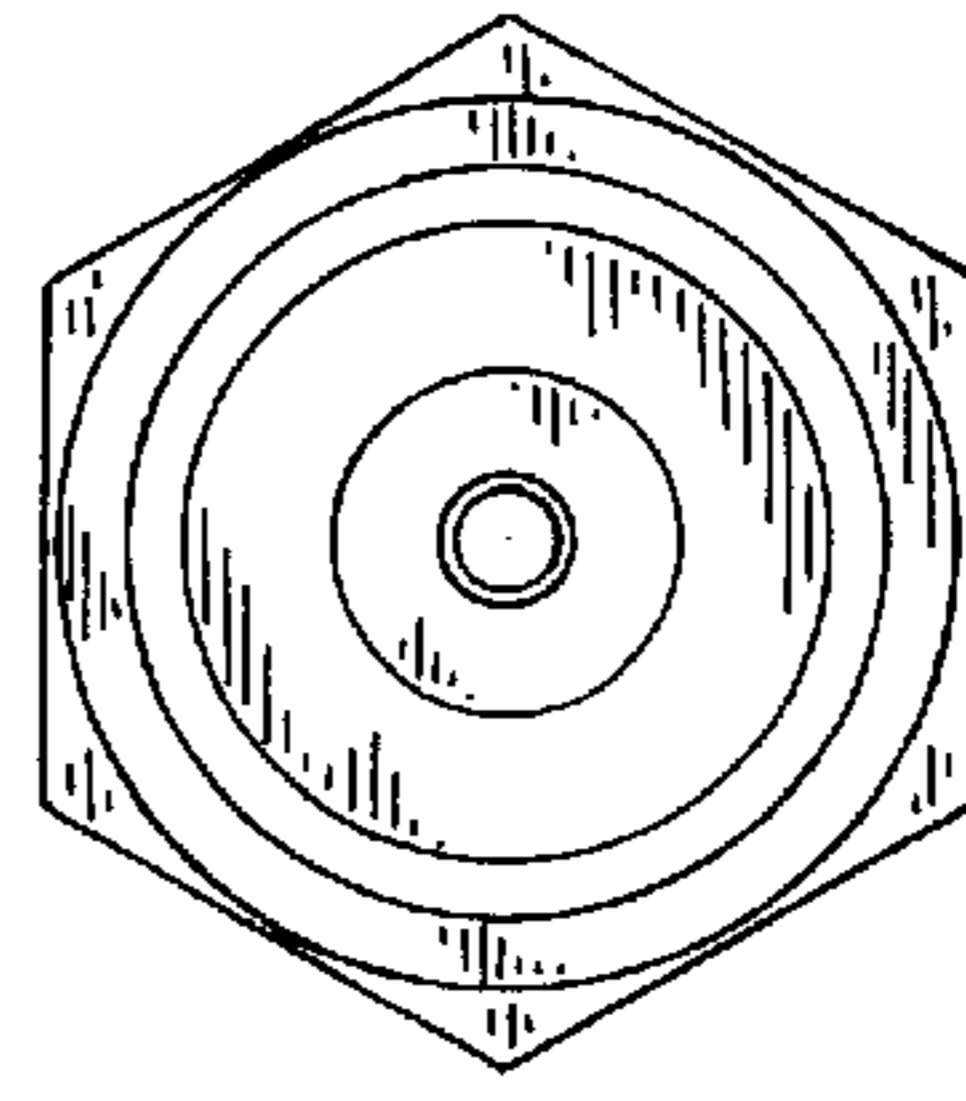

FIG. -6

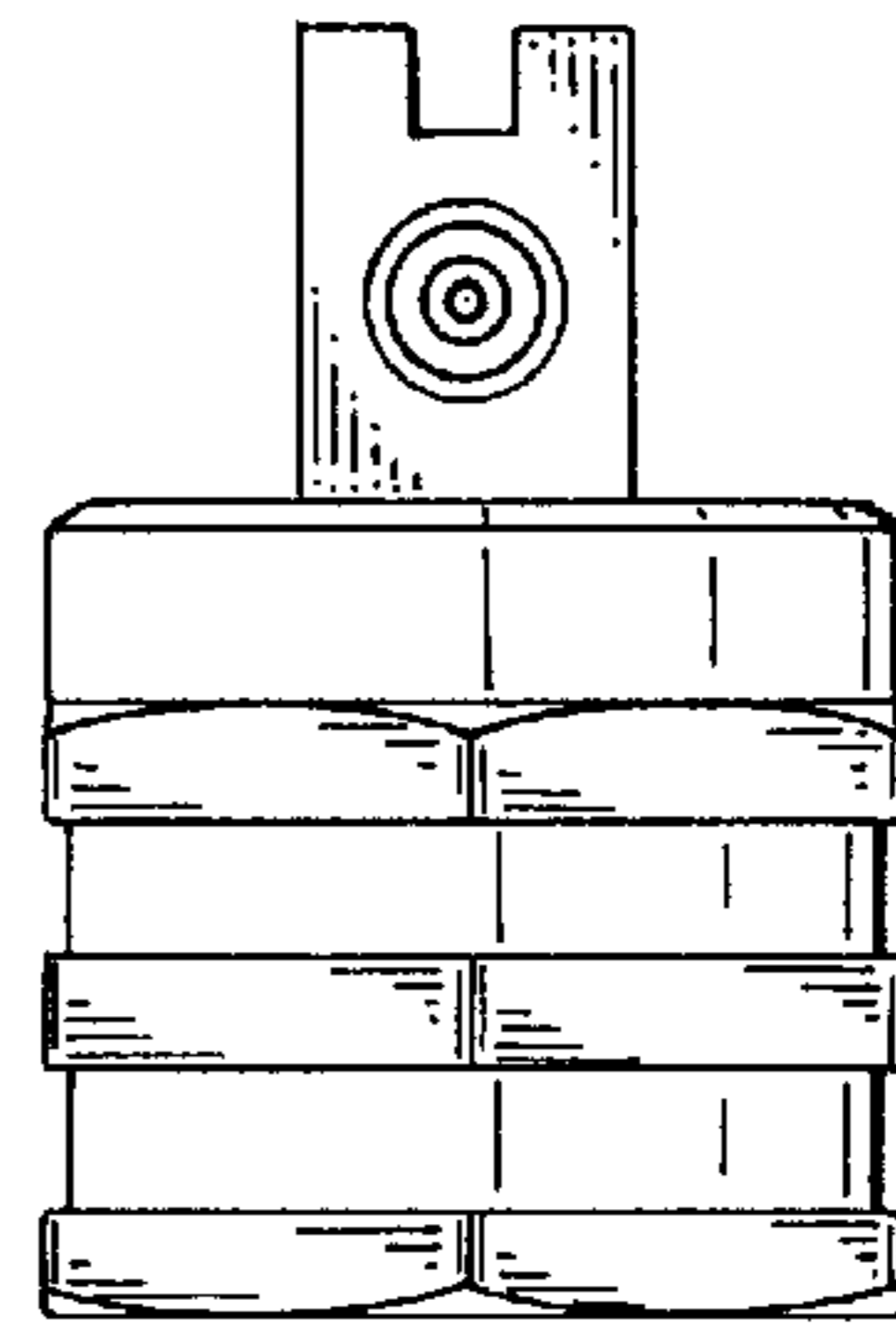

FIG. -7

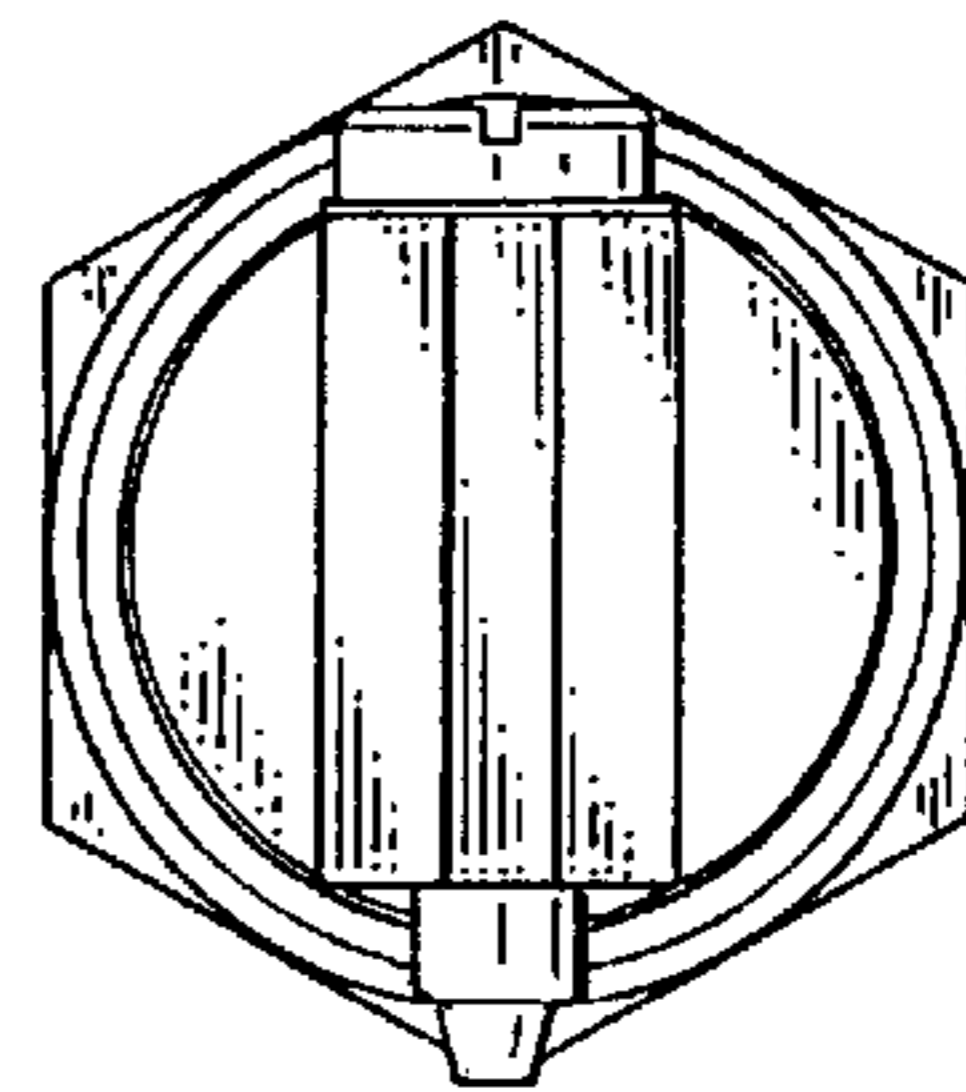
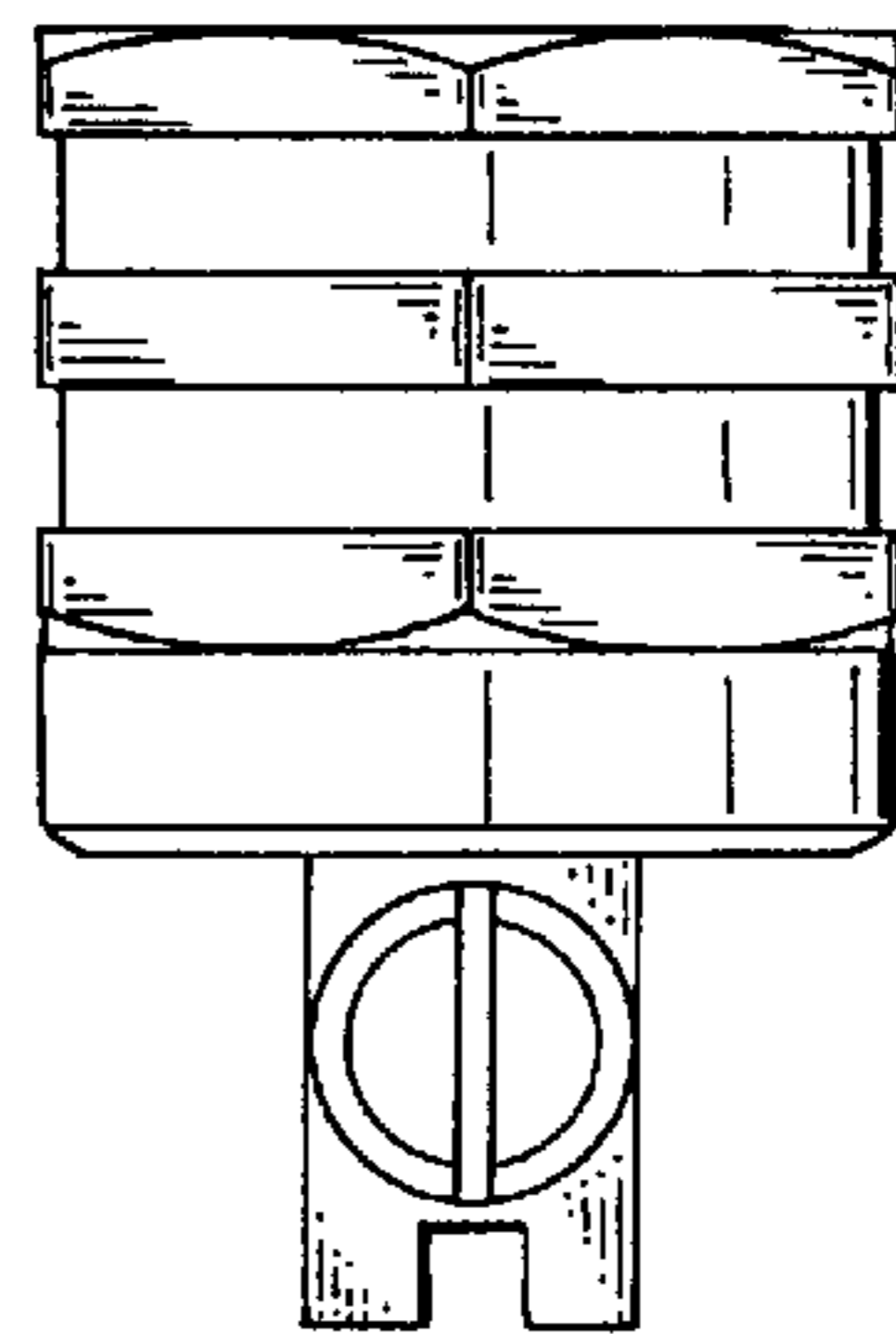

FIG. -4

FIG.-8

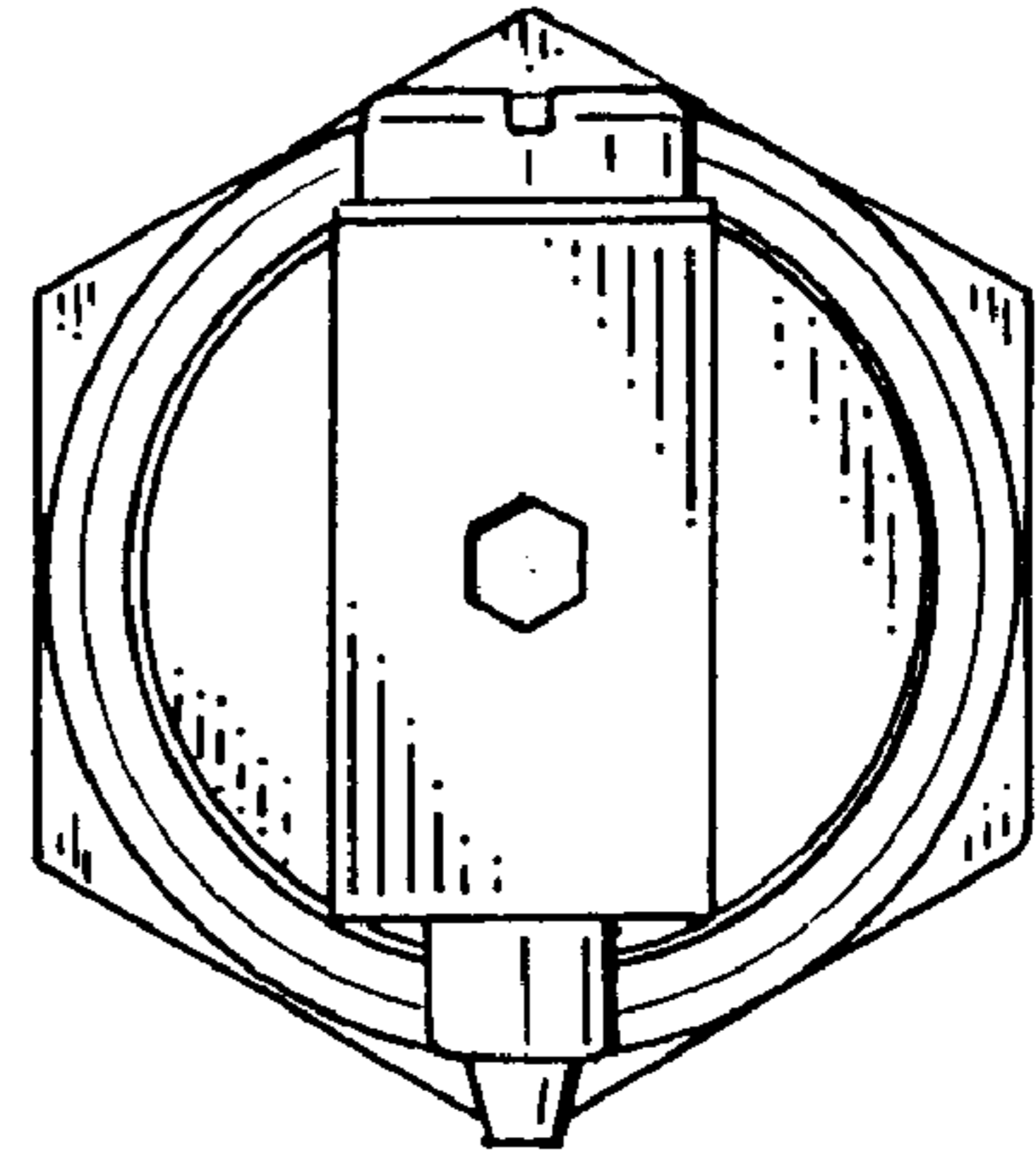

FIG.-9

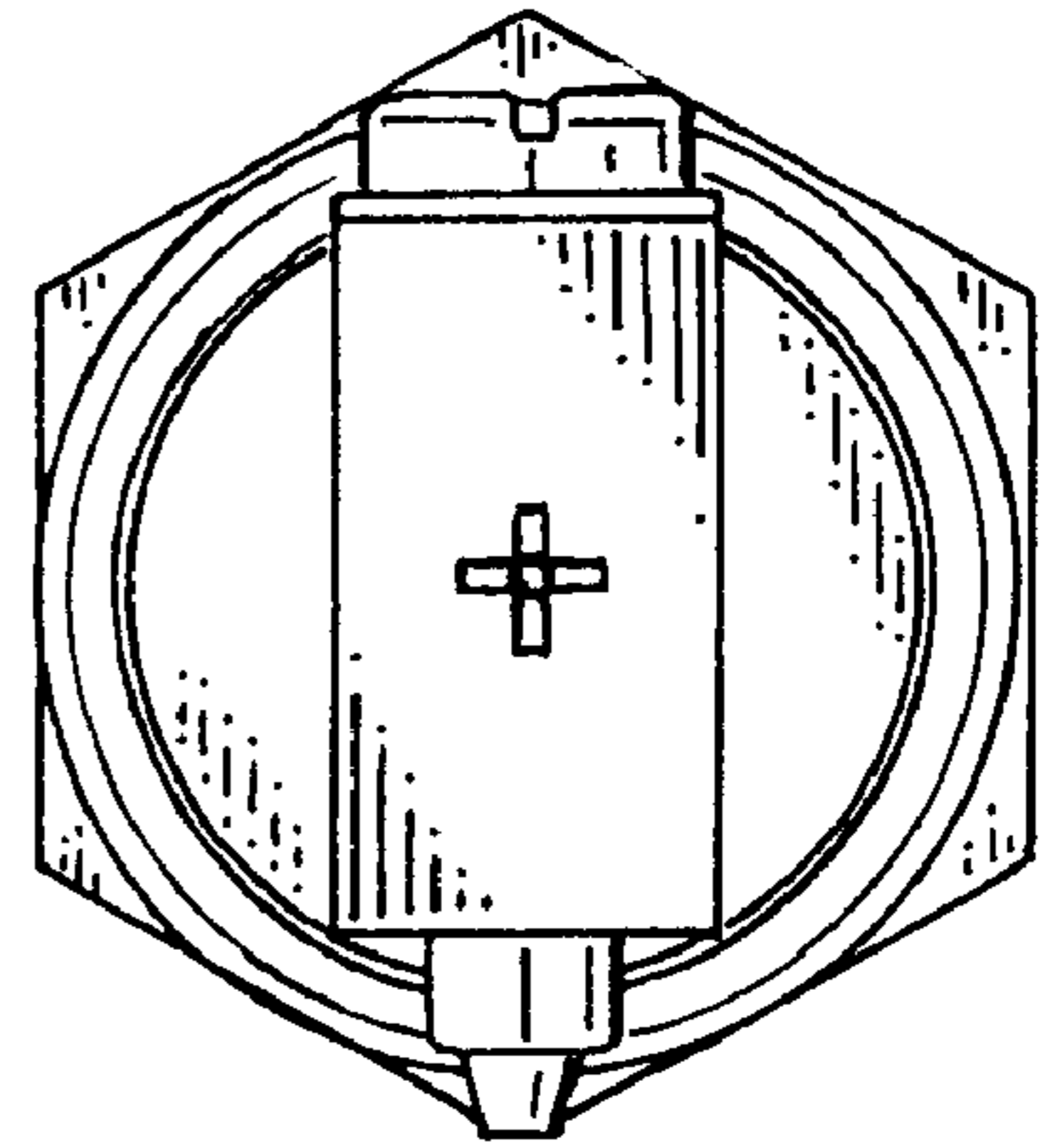

FIG.-10

