



US00D433657S

# United States Patent [19] Takizawa

[11] **Patent Number: Des. 433,657**

[45] **Date of Patent: \*\* Nov. 14, 2000**

[54] **BRAKE SHOE SUPPORT BODY**

[75] Inventor: **Shin'ichi Takizawa**, Sakai, Japan

[73] Assignee: **Shimano Inc.**, Osaka, Japan

[\*\*] Term: **14 Years**

[21] Appl. No.: **29/120,419**

[22] Filed: **Mar. 21, 2000**

### Related U.S. Application Data

[62] Division of application No. 29/077,793, Oct. 14, 1997.

[51] **LOC (7) Cl.** ..... **12-16**

[52] **U.S. Cl.** ..... **D12/180**

[58] **Field of Search** ..... D12/179, 180;  
188/173.1, 24.11-24.15, 24.19, 24.22

### [56] References Cited

#### U.S. PATENT DOCUMENTS

D. 281,874	12/1985	King	.....	D12/180
D. 295,847	5/1988	Everett	.....	D12/180
D. 379,344	5/1997	Everett	.....	D12/180
D. 384,018	9/1997	Nishimura	.....	D12/179
3,305,048	2/1967	Brilando	.....	188/24
3,840,093	10/1974	Hamayasu	.....	188/24
5,655,629	8/1997	Takizawa et al.	.....	188/24.12

#### OTHER PUBLICATIONS

U.S. application No. 29/120,413, filed Mar. 21, 2000, pending.

U.S. application No. 29/120,417, filed Mar. 21, 2000, pending.

U.S. application No. 29/120,420, filed Mar. 21, 2000, pending.

*Primary Examiner*—Alan P. Douglas

*Assistant Examiner*—Linda Brooks

*Attorney, Agent, or Firm*—Shinju Global IP Counselors, LLP

### [57] CLAIM

The ornamental design for a brake shoe support body, as shown and described.

### DESCRIPTION

FIG. 1 is a perspective view of the brake shoe support body showing my new design in accordance with one embodiment of the present invention, with a brake pad and an attachment screw shown in broken lines;

FIG. 2 is a bottom view of the brake shoe support body depicted in FIG. 1, showing my new design, with the attachment screw removed for clarity and the brake pad shown in broken lines;

FIG. 3 is a side view of the brake shoe support body depicted in FIG. 1, showing my new design, with the attachment screw removed for clarity and the brake pad shown in broken lines;

FIG. 4 is a top view of the brake shoe support body depicted in FIG. 1, showing my new design, with the attachment screw removed for clarity and the brake pad shown in broken lines; and,

FIG. 5 is an end view of the brake shoe support body depicted in FIG. 1, showing my new design, with the attachment screw removed for clarity and the brake pad shown in broken lines.

A view showing the portion of the brake shoe support body where the brake pad is attached is not provided because there is no ornamentation on that surface of the brake shoe support body. A further end view of each embodiment of the brake shoe support body is not provided because the end views are generally mirror images of one another.

The broken line showing of environment features shown throughout the drawings are for illustrative purposes only and forms no part of the claimed design.

**1 Claim, 2 Drawing Sheets**

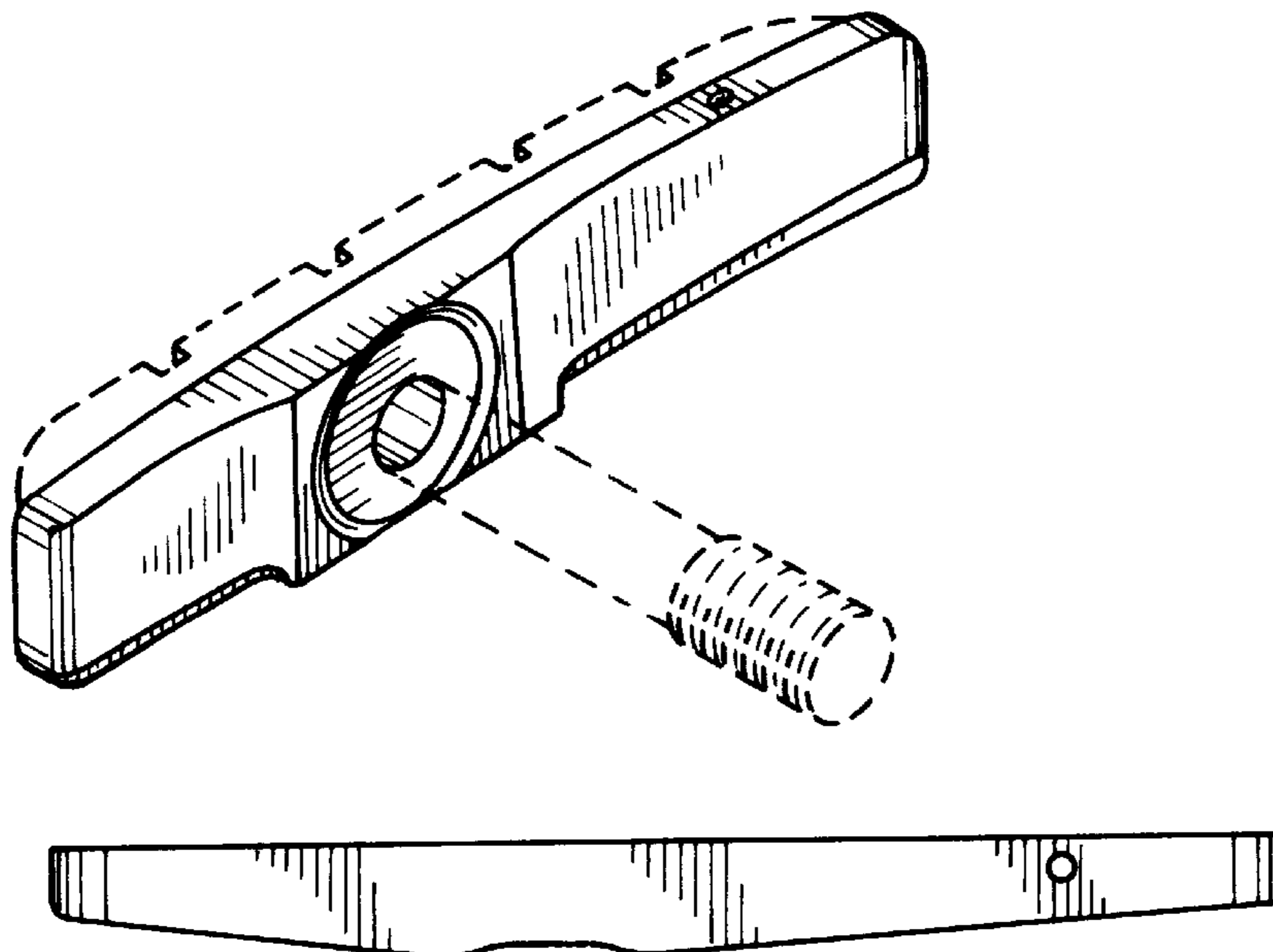

FIG. 1

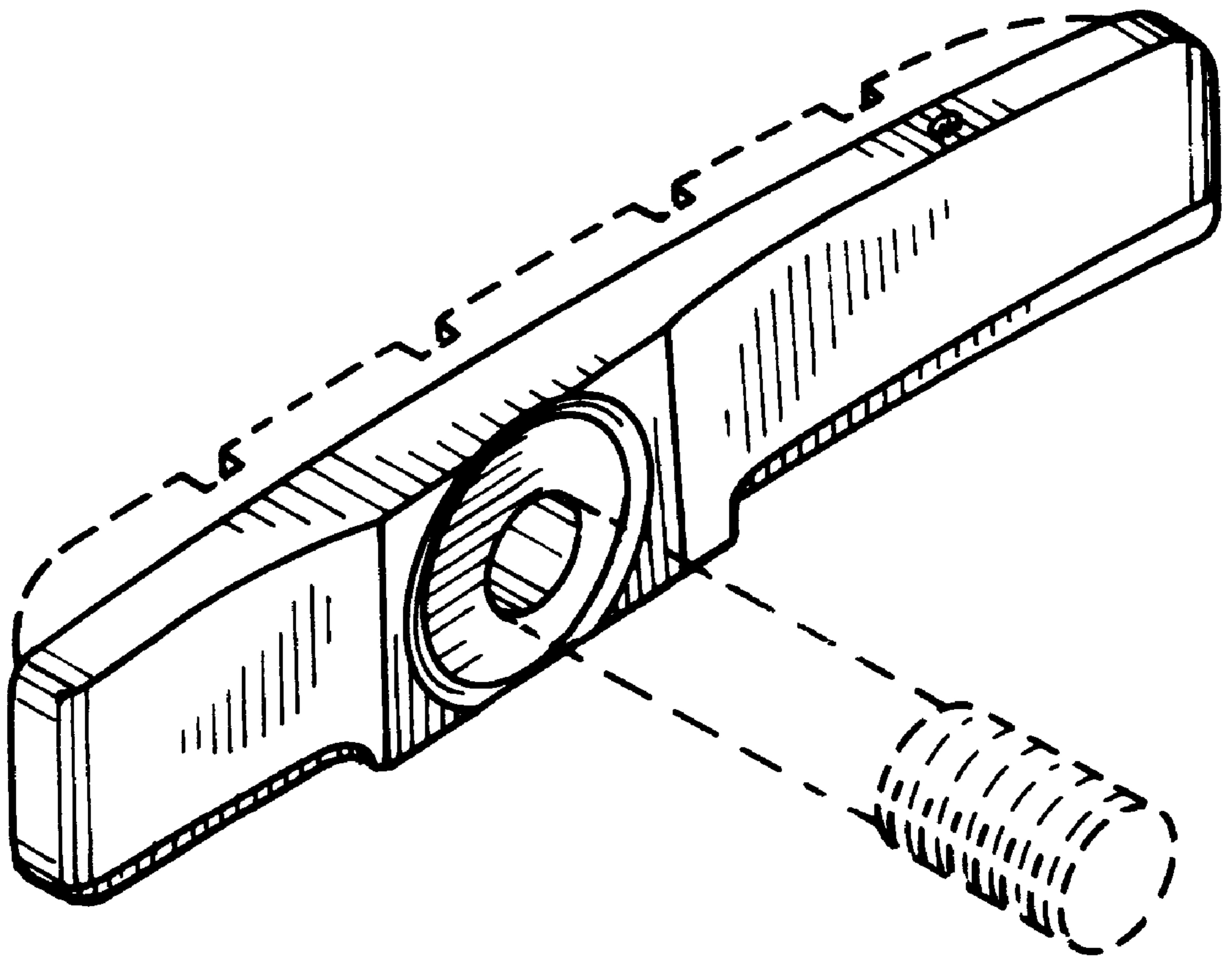

FIG. 2



FIG. 3

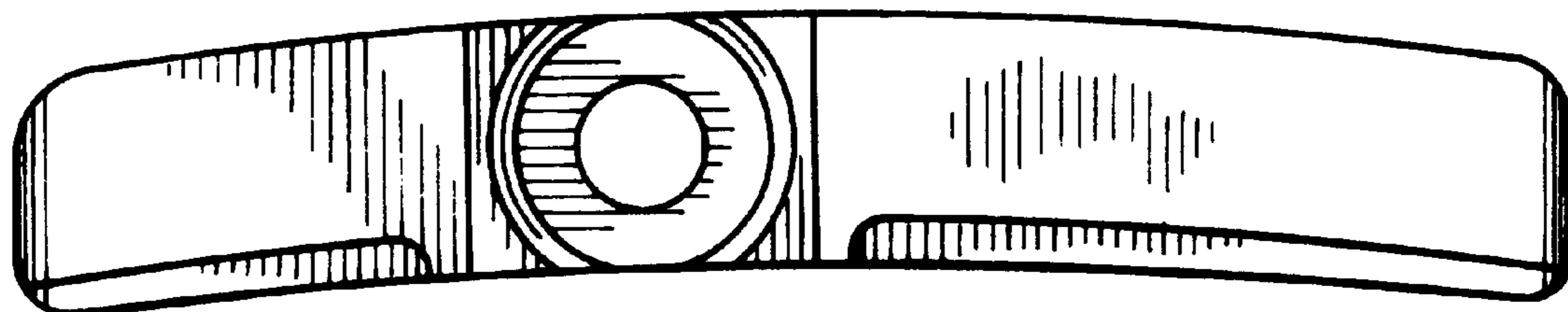

FIG. 4



FIG. 5

