



US00D433645S

United States Patent [19]

Hanson

[11] Patent Number: Des. 433,645

[45] Date of Patent: ** Nov. 14, 2000

[54] VEHICLE ALARM AND PAGER SYSTEM

[76] Inventor: **Tiffany Hanson**, 20 Hazelwood Dr., Hudson, N.H. 03051

[**] Term: **14 Years**

[21] Appl. No.: **29/121,064**

[22] Filed: **Mar. 31, 2000**

[51] LOC (7) Cl. **10-05**

[52] U.S. Cl. **D10/106**

[58] Field of Search D10/104, 106, D10/116, 121; 340/540, 541, 545, 565, 568, 571, 572, 573, 584

[56] **References Cited**

U.S. PATENT DOCUMENTS

- D. 376,767 12/1996 Duran D10/106
- D. 394,408 5/1998 Davila D10/106
- D. 395,836 7/1998 Morelli, Jr. D10/106

Primary Examiner—Marcus A. Jackson

[57] **CLAIM**

The ornamental design for a vehicle alarm and pager system, as shown and described.

DESCRIPTION

FIG. 1 is a front elevational view of the vehicle alarm and pager system of the present invention;
 FIG. 2 is a rear elevational view of the vehicle alarm and pager system of FIG. 1;
 FIG. 3 is a left side elevational view of the vehicle alarm and pager system of FIG. 1;
 FIG. 4 is a right side elevational view of the vehicle alarm and pager system of FIG. 1;
 FIG. 5 is a top plan view of the vehicle alarm and pager system of FIG. 1; and,
 FIG. 6 is a bottom plan view of the vehicle alarm and pager system of FIG. 1.
 The broken lines showing of Numbers and Letters in FIG. 1 are for illustrative purposes only and form no part of the claimed design.

1 Claim, 3 Drawing Sheets

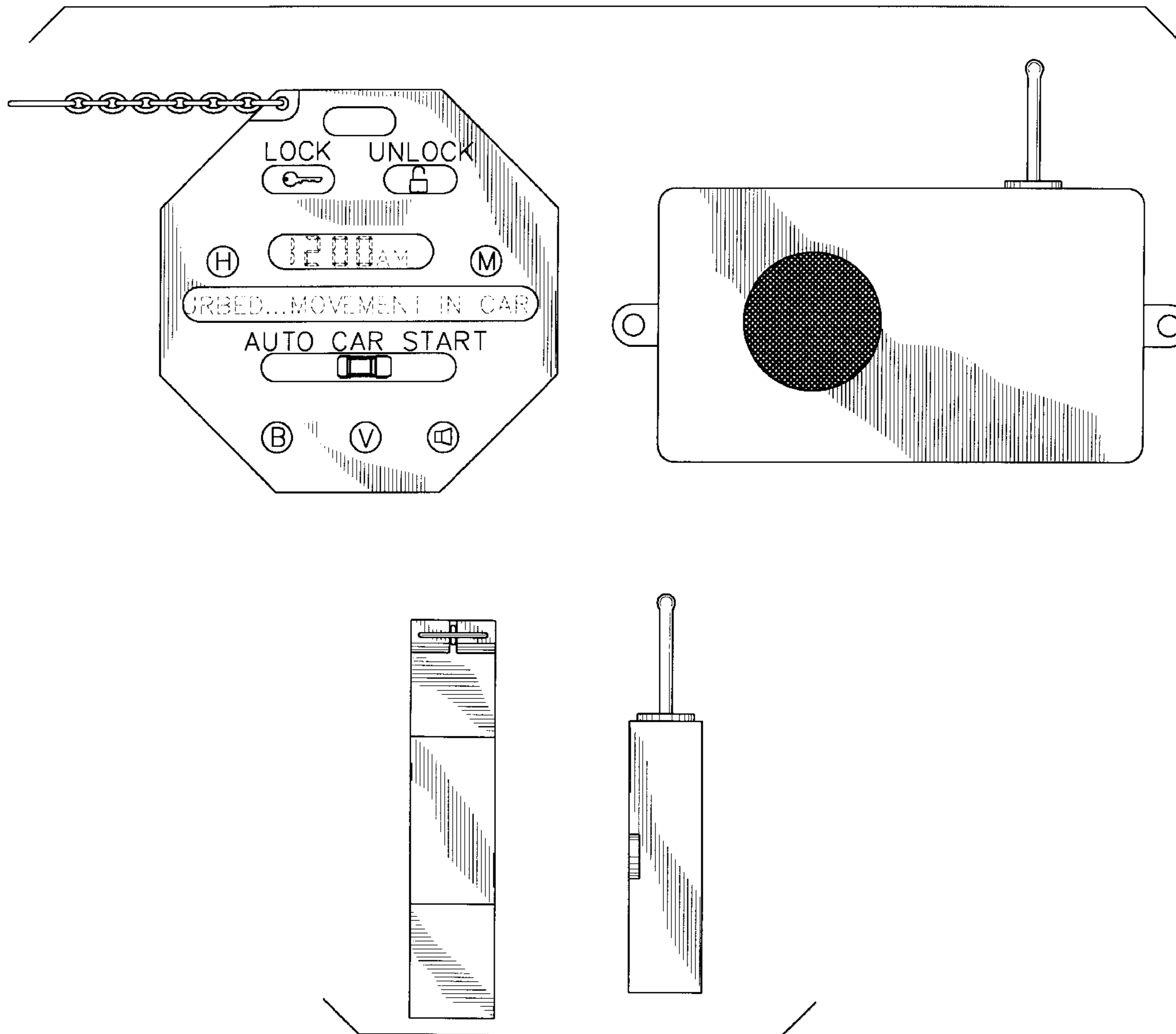

FIG. 1

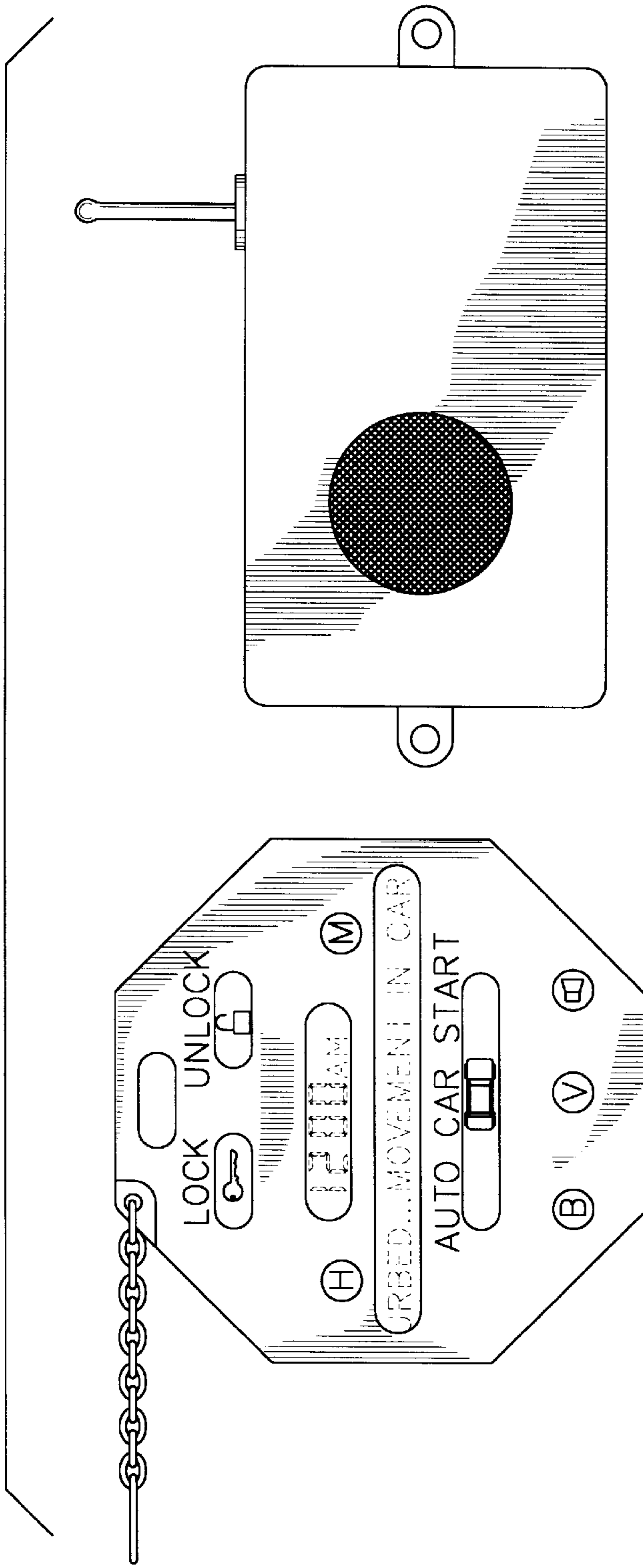

FIG. 6

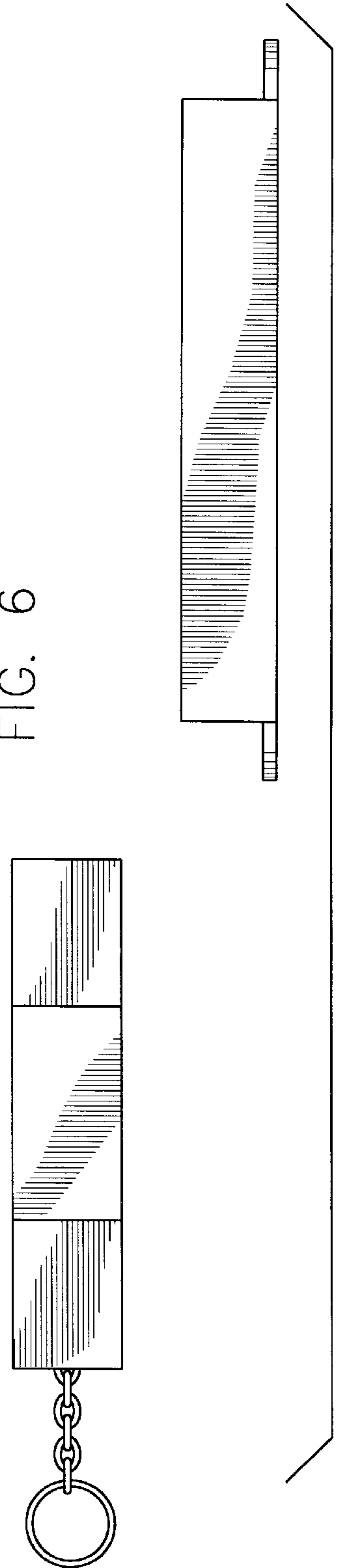

FIG. 5

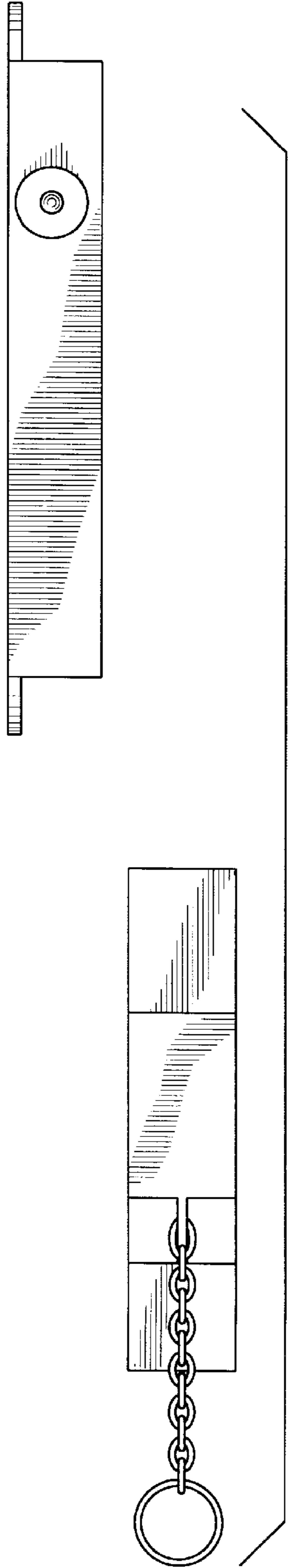
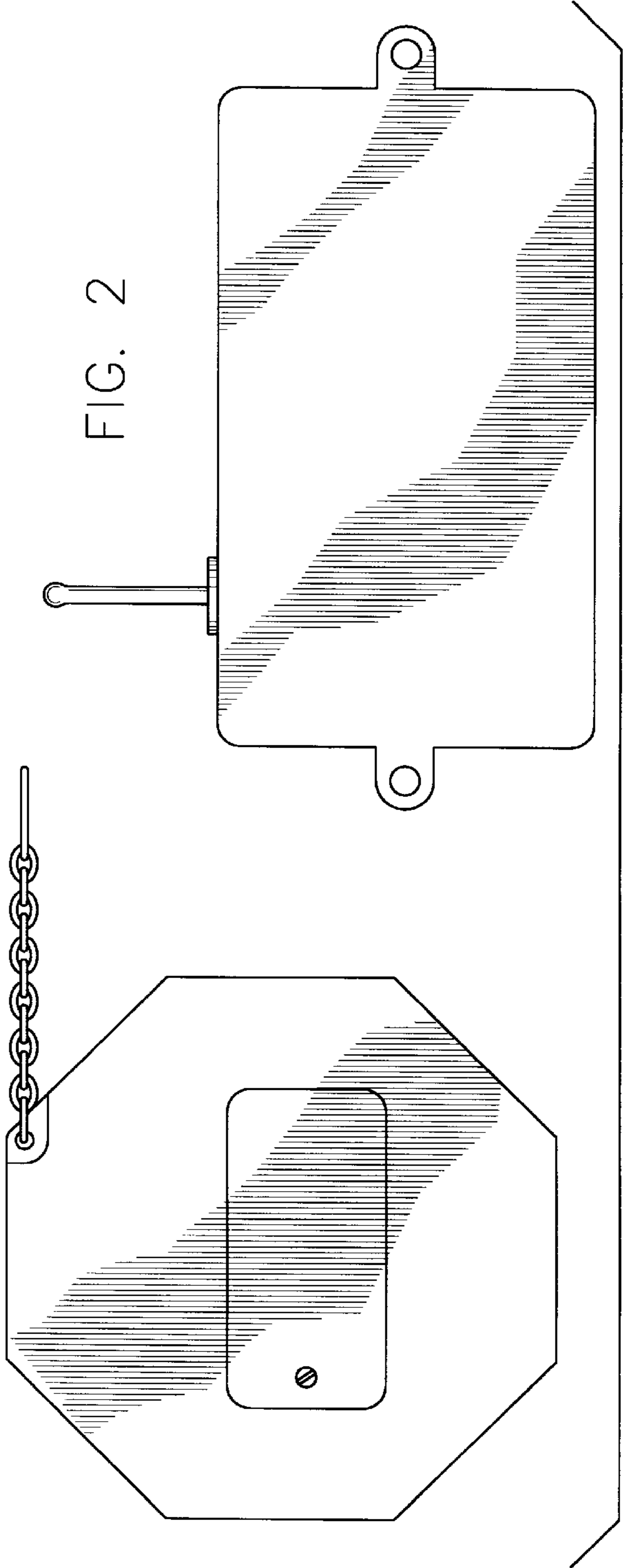

FIG. 2



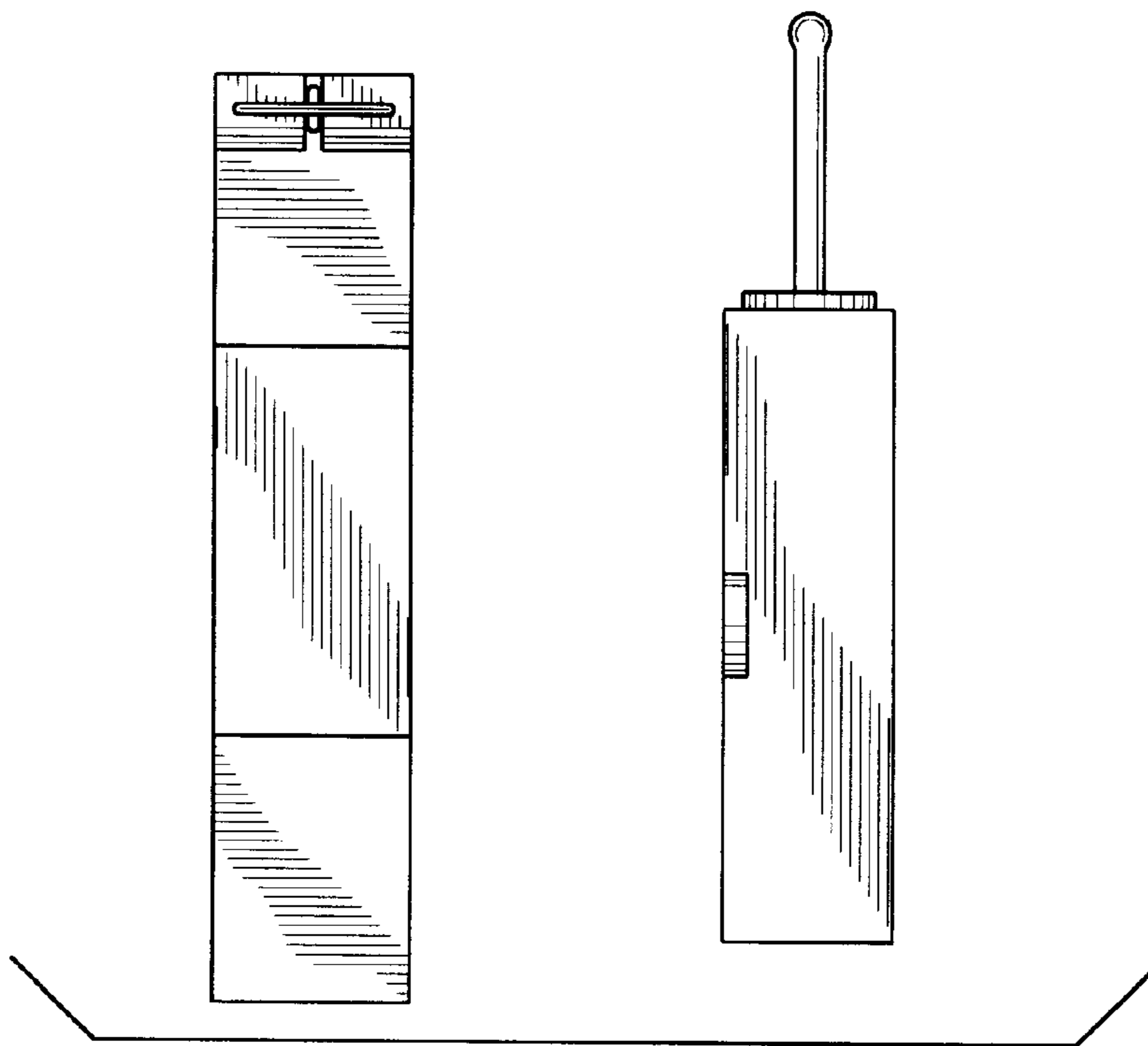

FIG. 3

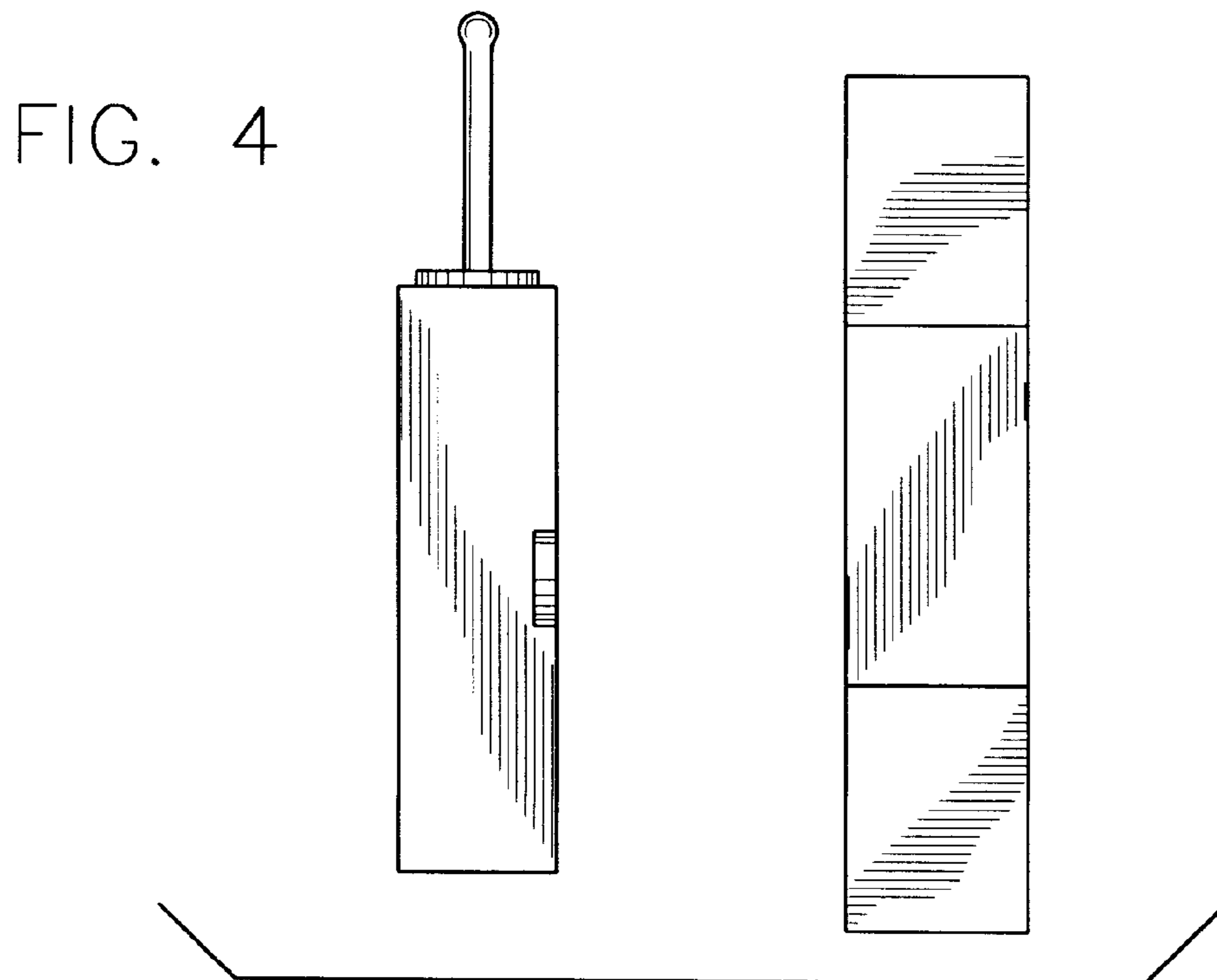

FIG. 4