



US00D433530S

United States Patent [19]

Barry

[11] Patent Number: Des. 433,530

[45] Date of Patent: ** Nov. 7, 2000

[54] **LAMP WITH FLUTED STEM OF SQUARE CROSS SECTION**

[75] Inventor: **Barbara Barry**, Los Angeles, Calif.

[73] Assignee: **Boyd Lighting Company**, San Francisco, Calif.

[**] Term: **14 Years**

[21] Appl. No.: **29/119,904**

[22] Filed: **Mar. 8, 2000**

[51] **LOC (7) Cl.** **26-03**

[52] **U.S. Cl.** **D26/112**

[58] **Field of Search** D26/93, 102-112;
362/410-414

[56] **References Cited**

U.S. PATENT DOCUMENTS

D. 393,917 4/1998 Hutton D26/106

OTHER PUBLICATIONS

George Kovacs Lighting Catalog, lamps 4071 and 4072 on p. 24, 1987-88.

Bradley Table Lamps sales brochure, square column lamp No. 2021, 1951-1952.

Primary Examiner—Alan P. Douglas

Assistant Examiner—Linda Brooks

Attorney, Agent, or Firm—Jack Lo

[57] **CLAIM**

The ornamental design for a lamp with fluted stem of square cross section, as shown and described.

DESCRIPTION

FIG. 1 is a front perspective view of a lamp with a fluted stem of square cross section showing my new design.

FIG. 2 is a front view thereof. A cylindrical finial is at the uppermost portion of the lamp above a tubular shade. A short neck of square cross section is between the shade and the fluted stem. The neck is wider than the finial. The back view, and opposite side views are identical.

FIG. 3 is a top view thereof. The dashed lines represent unclaimed subject matter positioned between the finial above the shade, and the neck below the shade.

FIG. 4 is a bottom view thereof. The dashed lines represent unclaimed subject matter.

FIG. 5 is a front perspective view of an alternative embodiment thereof.

FIG. 6 is a front view of the alternative embodiment. A cylindrical finial is at the uppermost portion of the lamp above a tubular shade. A short neck of square cross section is between the shade and the stem. The neck is wider than the finial. The back view, and opposite side views are identical.

FIG. 7 is a top view of the alternative embodiment. The dashed lines represent unclaimed subject matter positioned between the finial above the shade, and the neck below the shade; and,

FIG. 8 is a bottom view thereof. The dashed lines represent unclaimed subject matter.

1 Claim, 4 Drawing Sheets

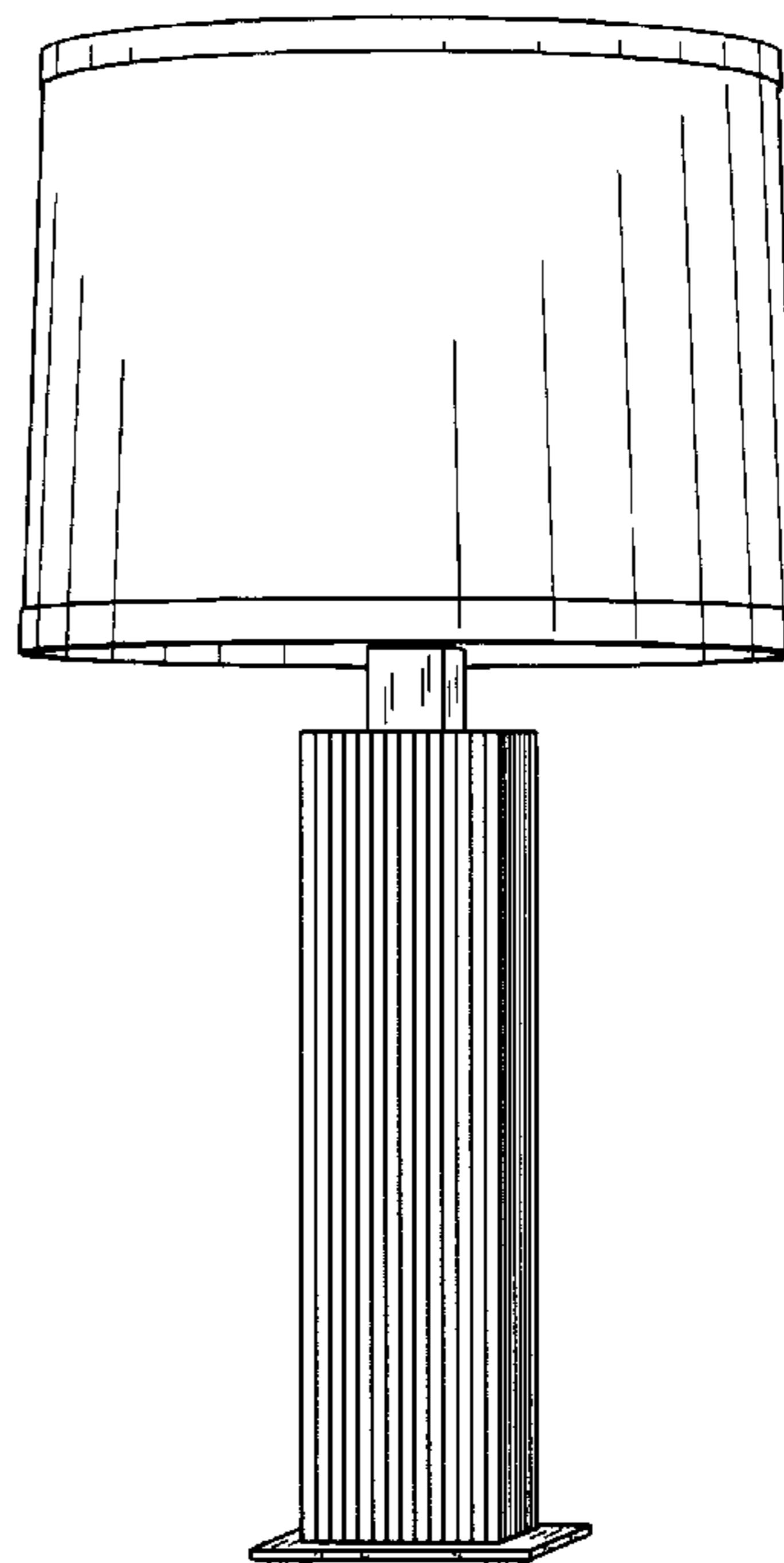
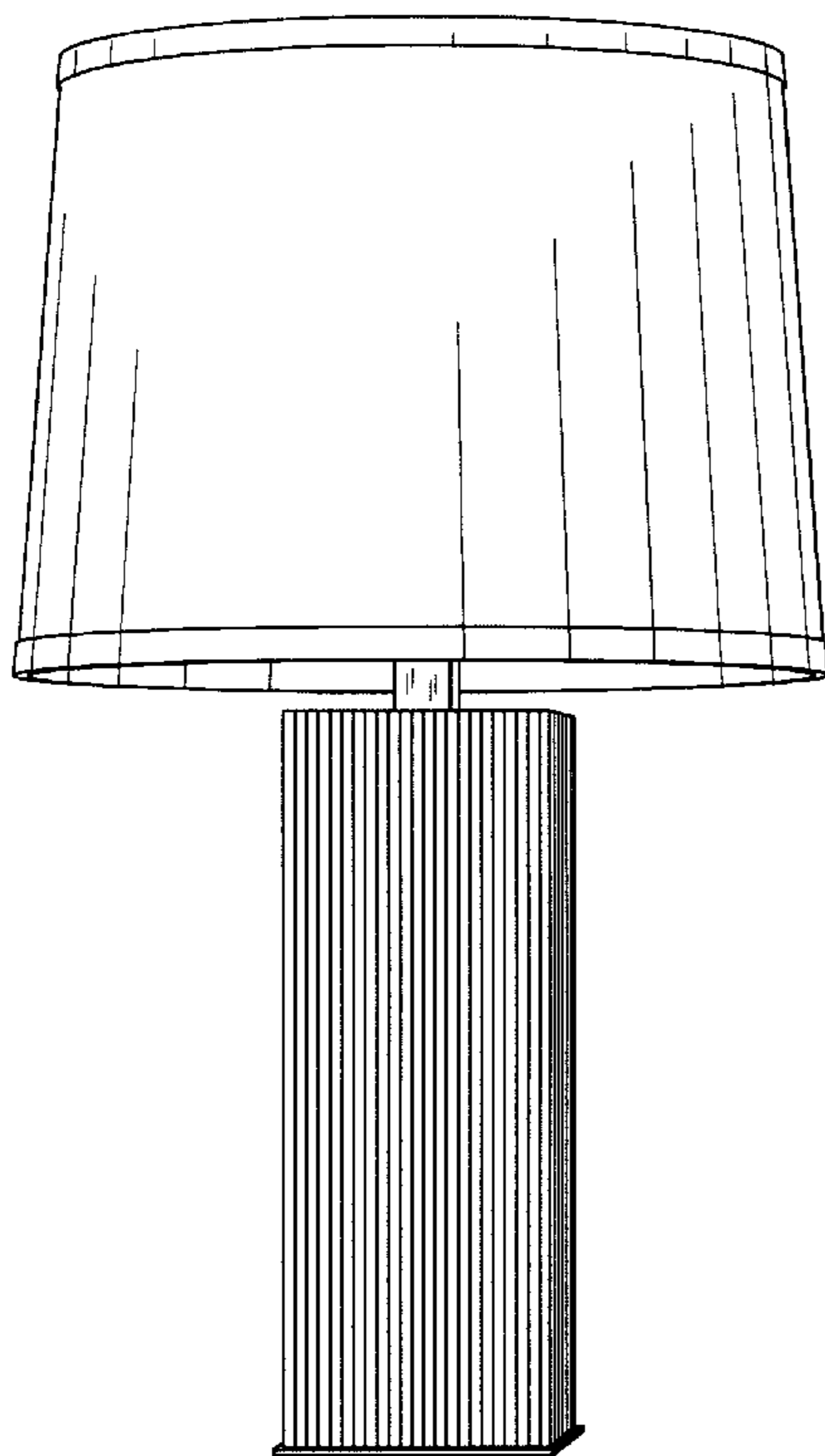

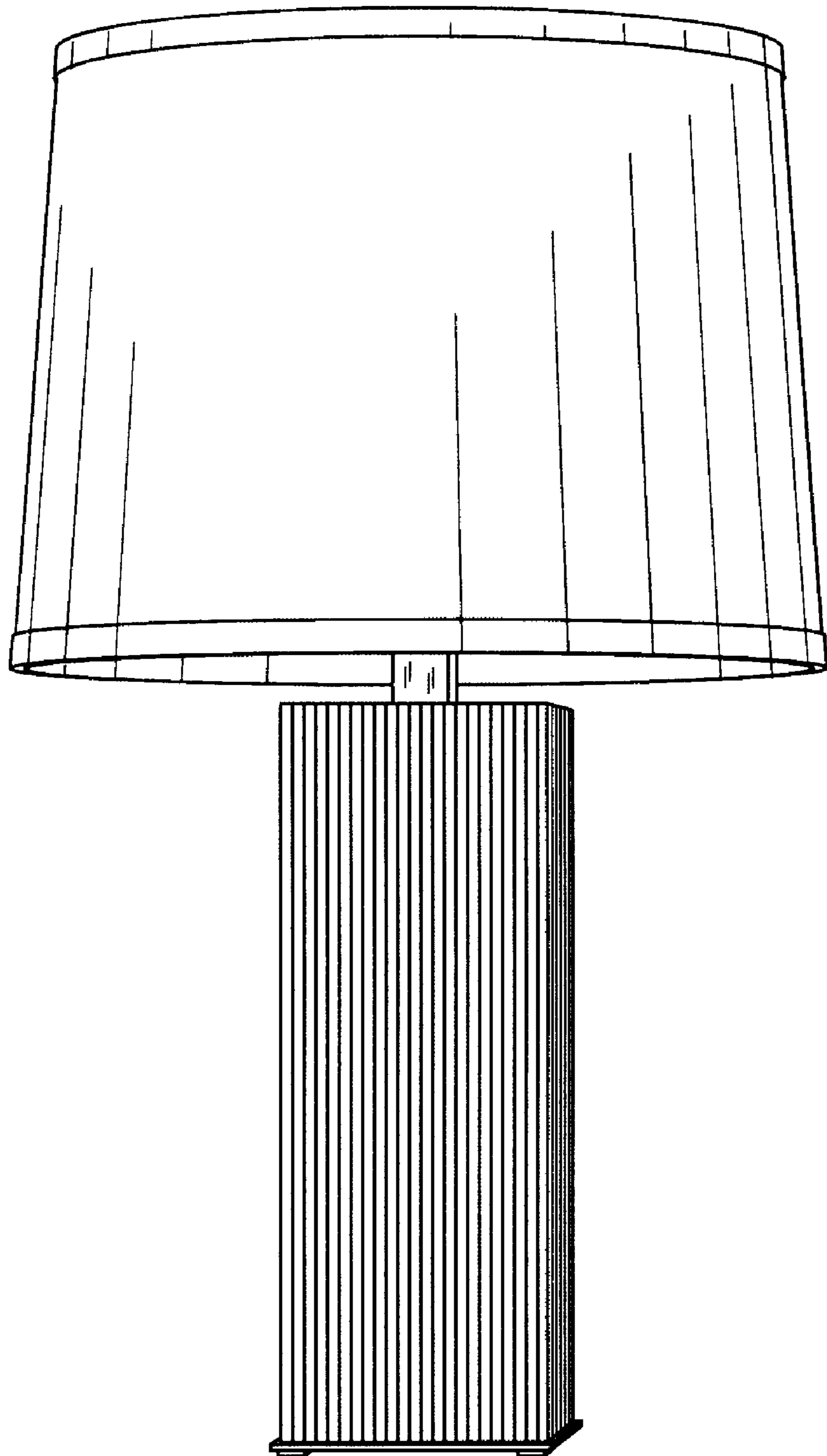

Fig. 1

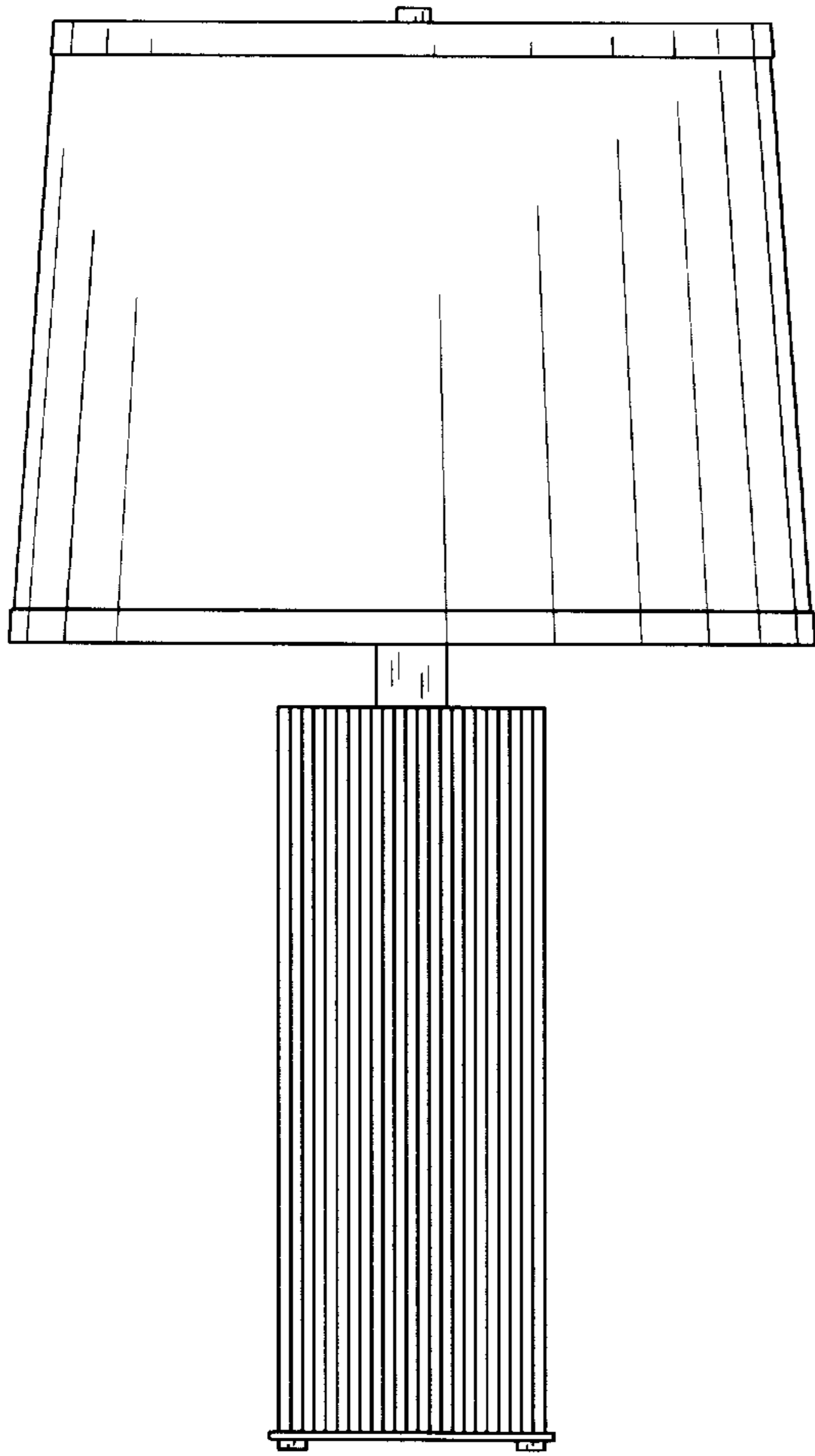

Fig. 2

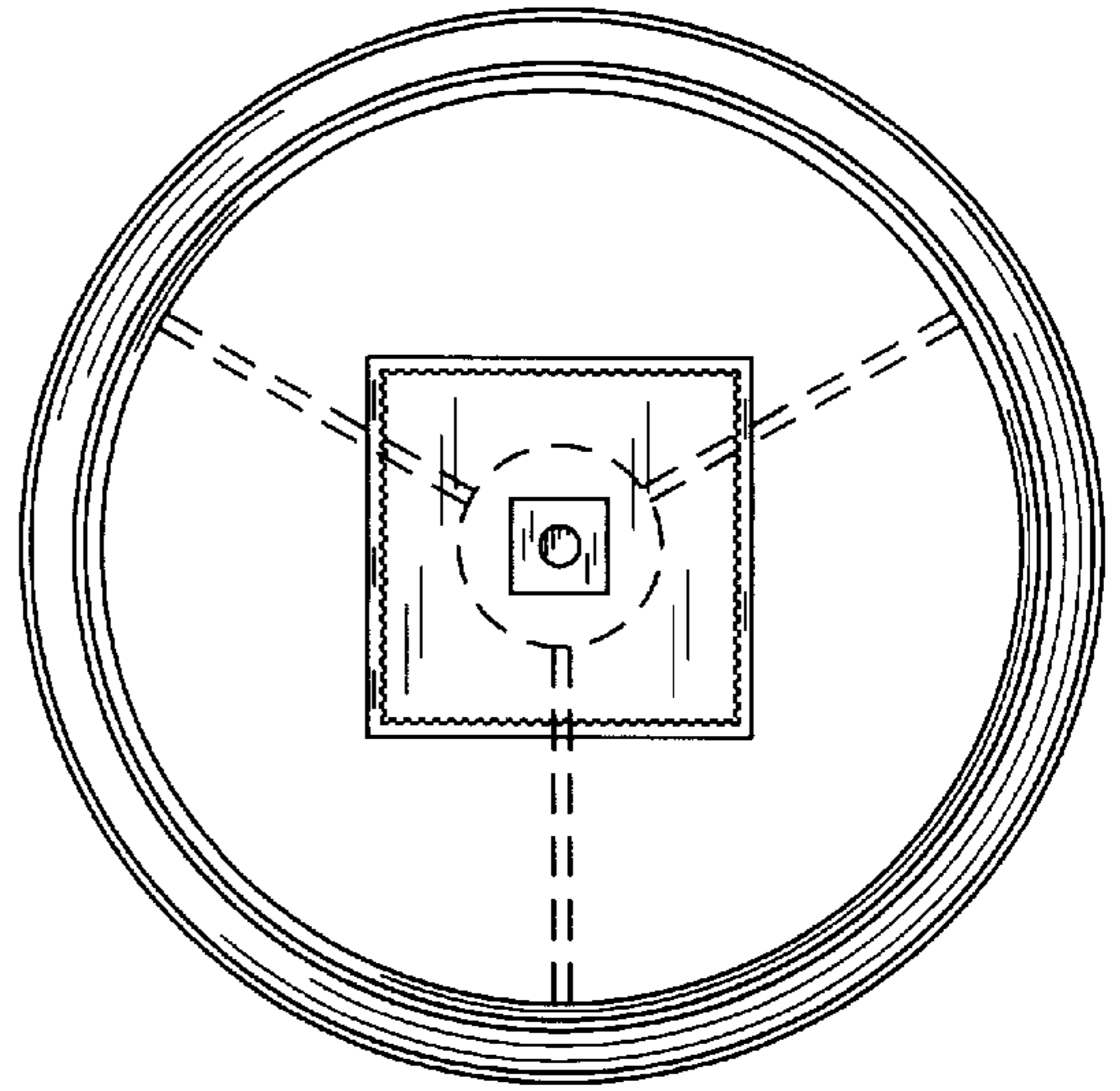

Fig. 3

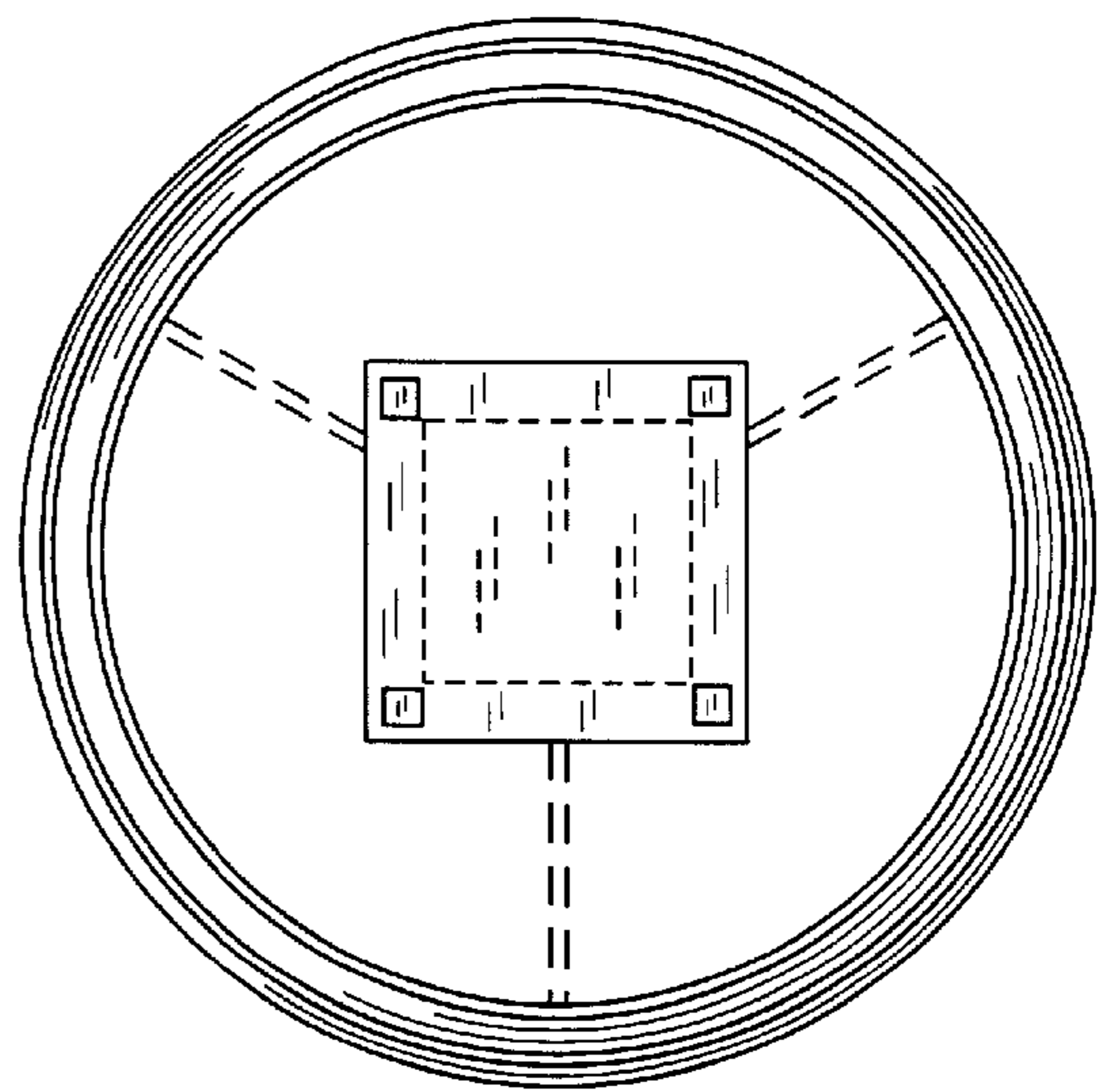

Fig. 4

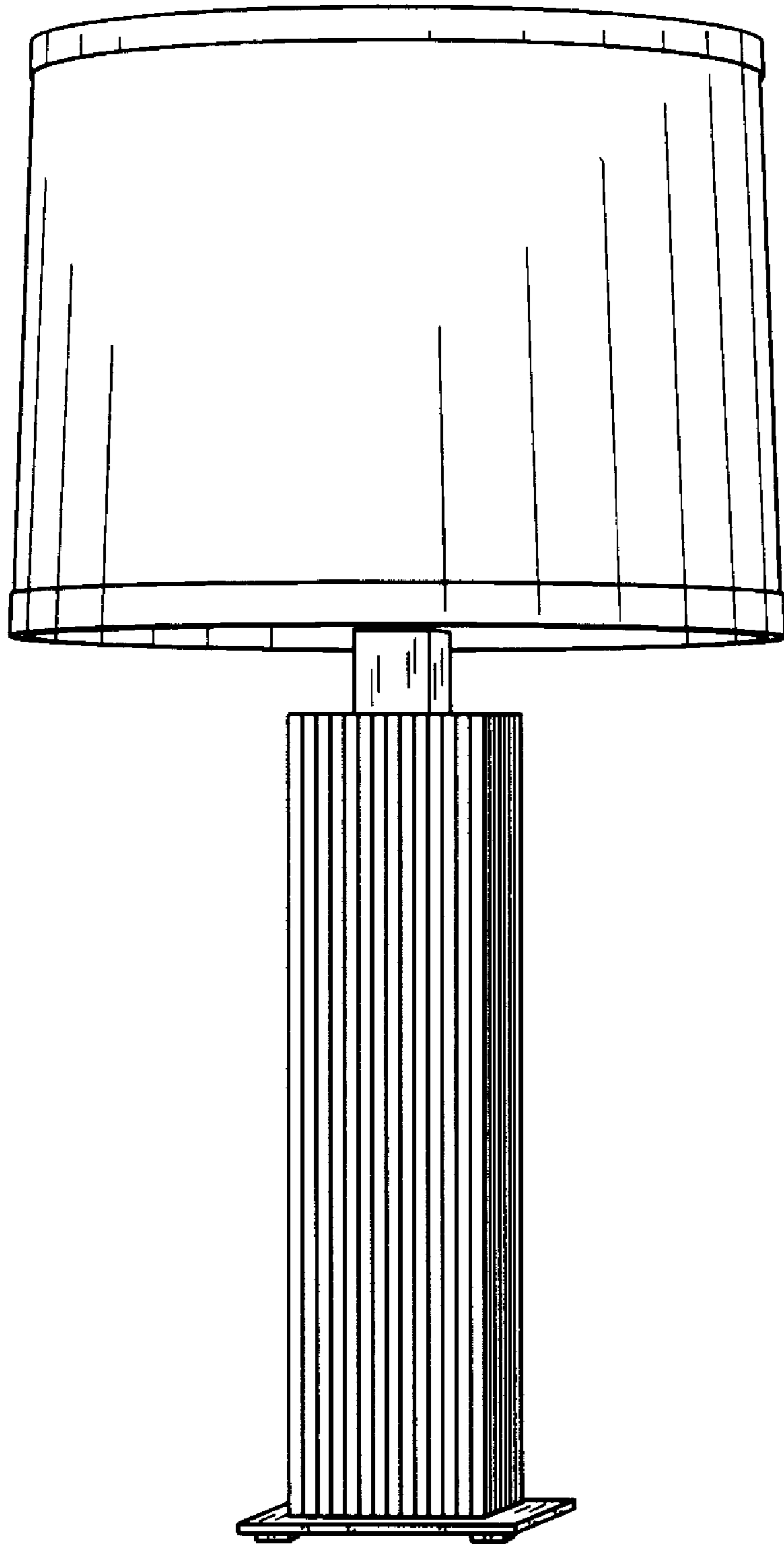

Fig. 5

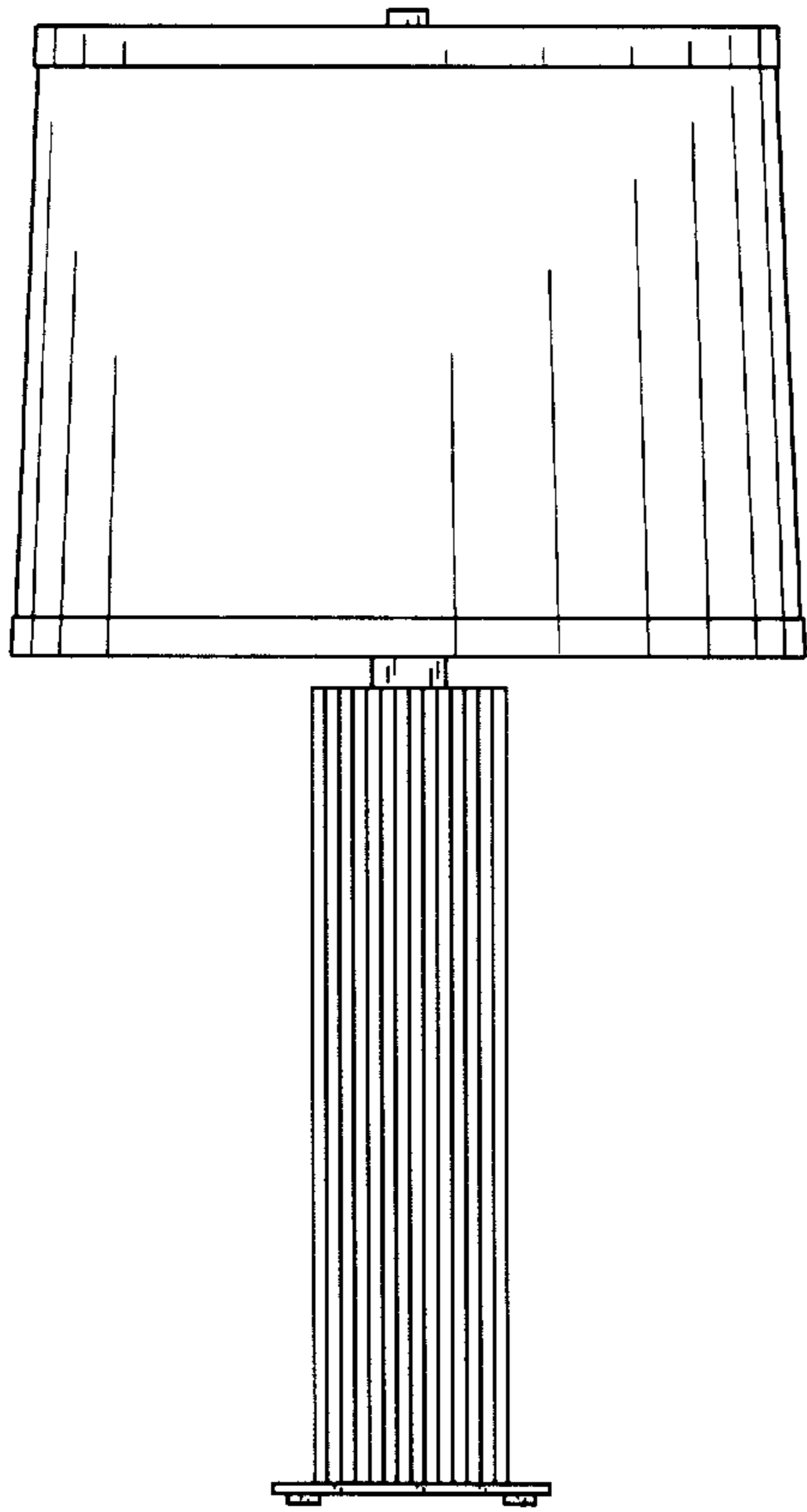

Fig. 6

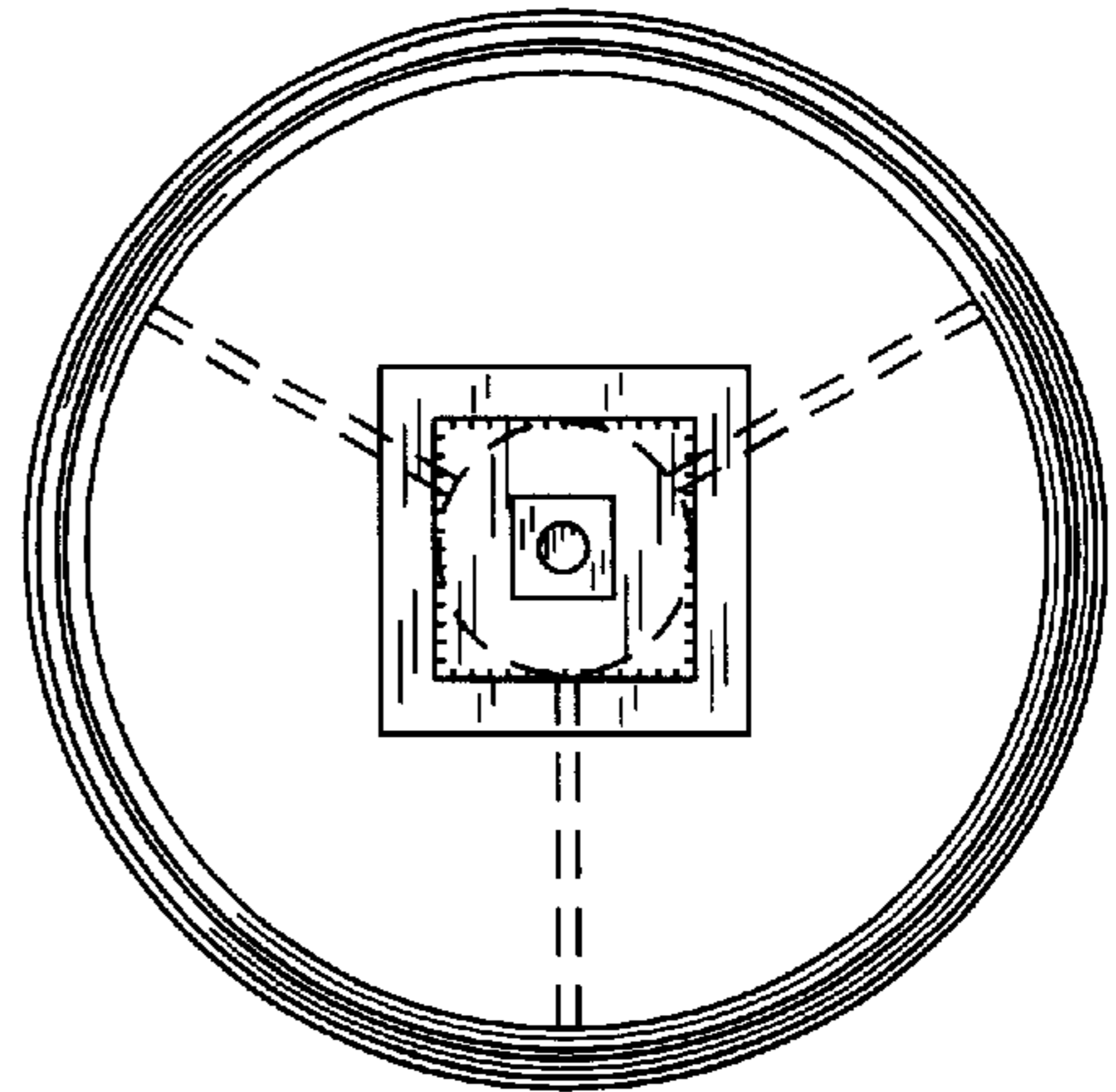

Fig. 7

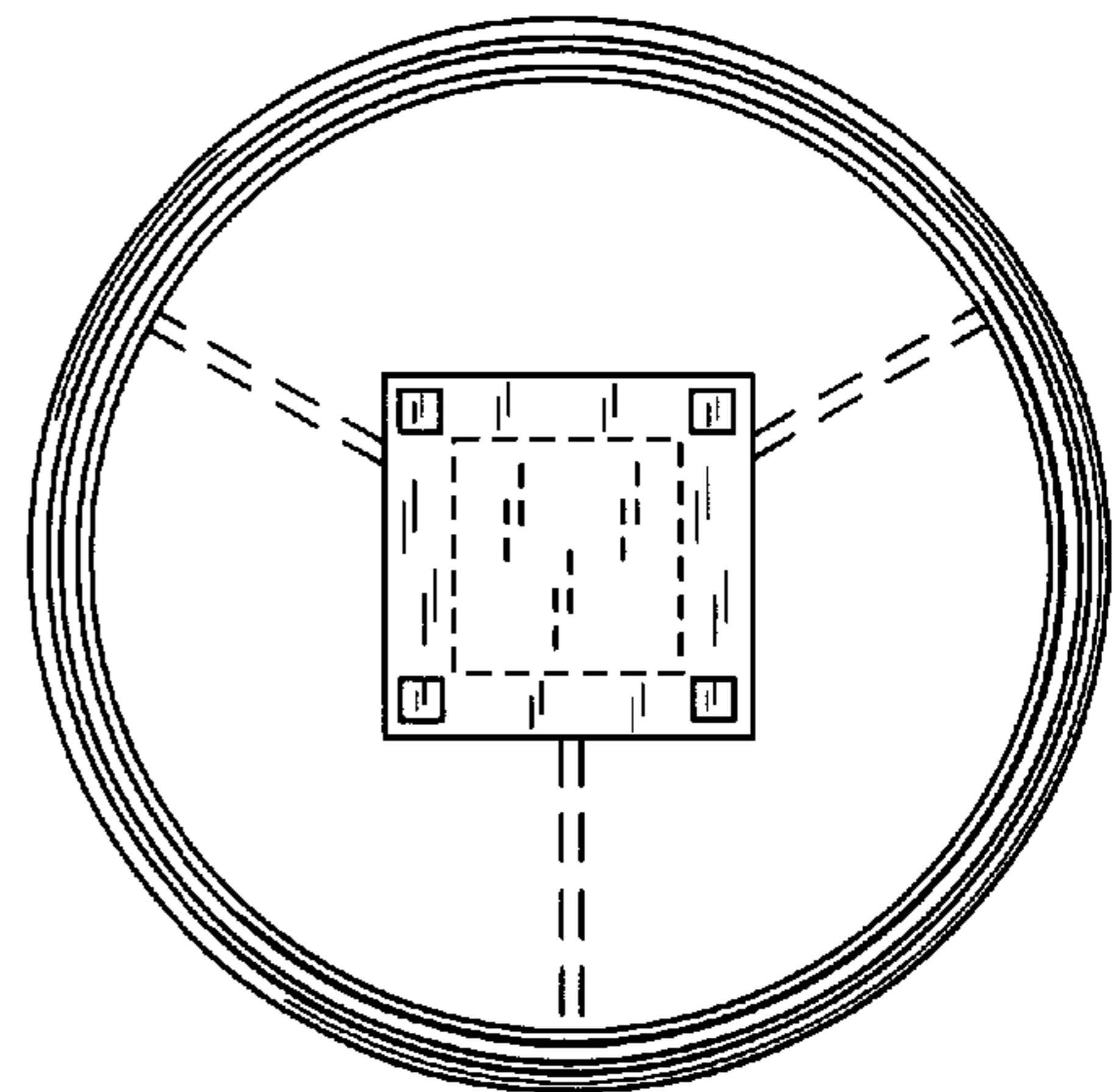

Fig. 8