



US00D433476S

**United States Patent** [19]  
**Lin**

[11] **Patent Number: Des. 433,476**

[45] **Date of Patent: \*\* Nov. 7, 2000**

[54] **HUB**  
[76] Inventor: **Tony Lin**, 6F, No.82, Sec.2, Chien Kwo  
N. Rd., Taipei, Taiwan  
[\*\*] Term: **14 Years**  
[21] Appl. No.: **29/108,590**  
[22] Filed: **Aug. 2, 1999**  
[51] **LOC (7) Cl.** ..... **21-02**  
[52] **U.S. Cl.** ..... **D21/779**  
[58] **Field of Search** ..... D21/760, 763-765,  
D21/779, 563; D12/207, 208; 280/11.19,  
11.22, 11.26; 301/5.3, 5.7

5,967,618 10/1999 Wimmer ..... 301/5.3  
5,979,992 11/1999 Calderone ..... 301/5.3

**OTHER PUBLICATIONS**

“Automobile”, P 103, Sep. 1996.  
*Primary Examiner*—Raphael Barkai  
*Attorney, Agent, or Firm*—Donald C. Casey, Esq.

[56] **References Cited**  
**U.S. PATENT DOCUMENTS**  
D. 400,613 11/1998 Demarchi ..... D21/764  
D. 421,083 2/2000 Chen ..... D21/779  
5,897,170 4/1999 Keleny ..... 280/11.22

[57] **CLAIM**  
The ornamental design for a hub, as shown and described.

**DESCRIPTION**

FIG. 1 is a prospective view of the hub of this invention; FIG. 2 is a right side view of the embodiment of FIG. 1; FIG. 3 is a left side view of the embodiment of FIG. 1; FIG. 4 is a front view of embodiment of FIG. 1; FIG. 5 is a back view of the embodiment of FIG. 1; FIG. 6 is a top view of the embodiment of FIG. 1; and, FIG. 7 is a bottom view of the embodiment of FIG. 1.

**1 Claim, 4 Drawing Sheets**

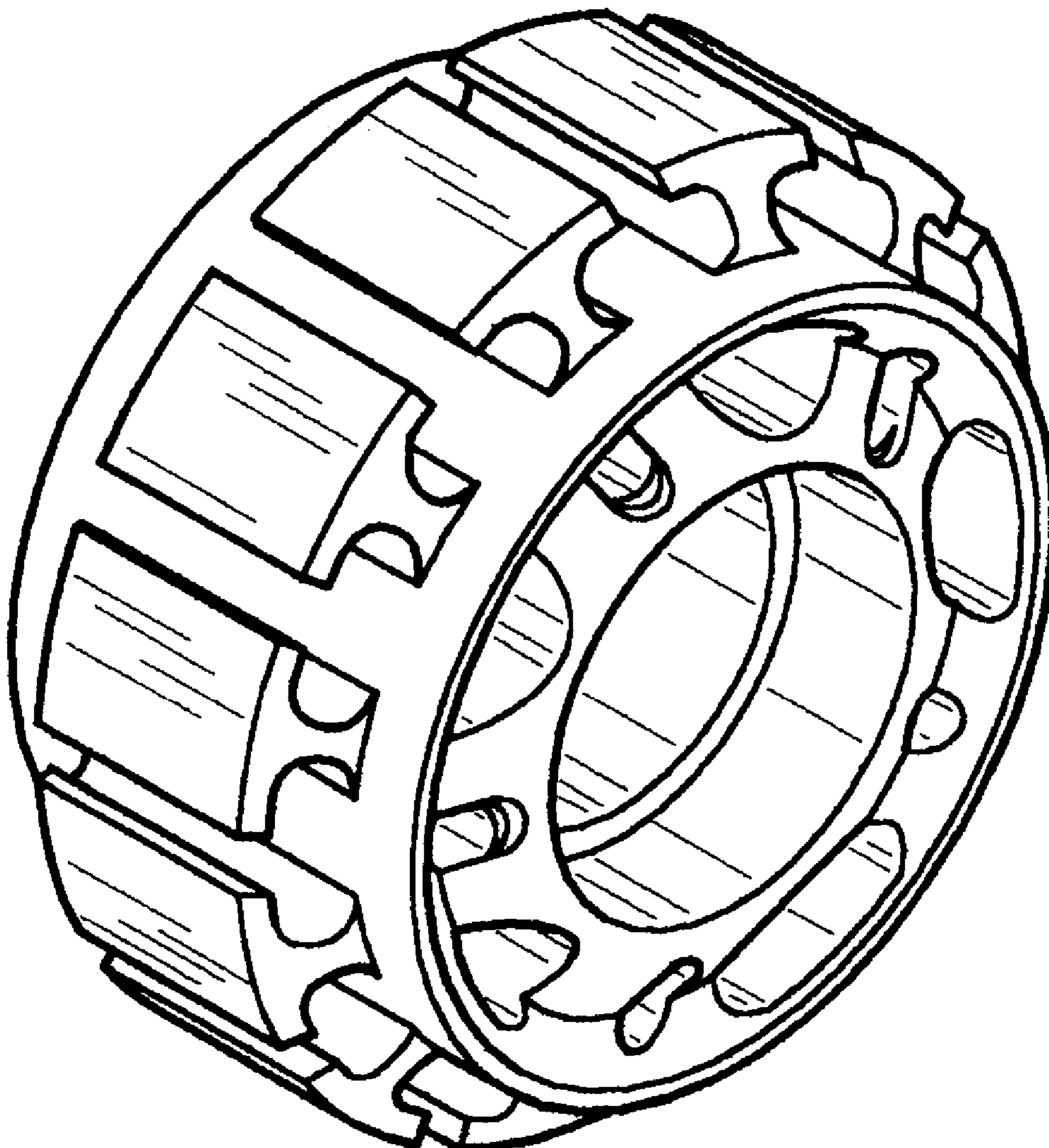

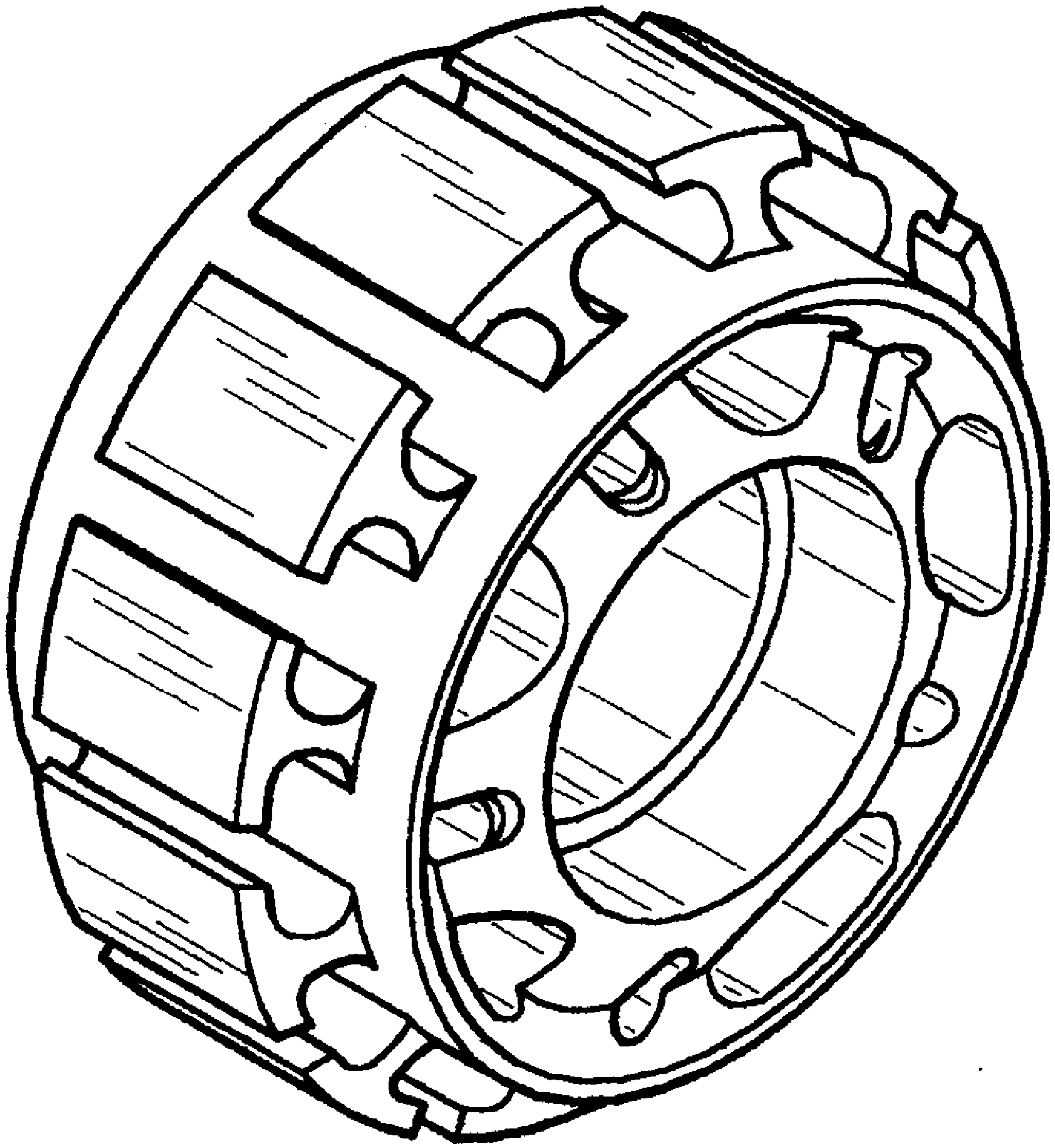

FIG. 1

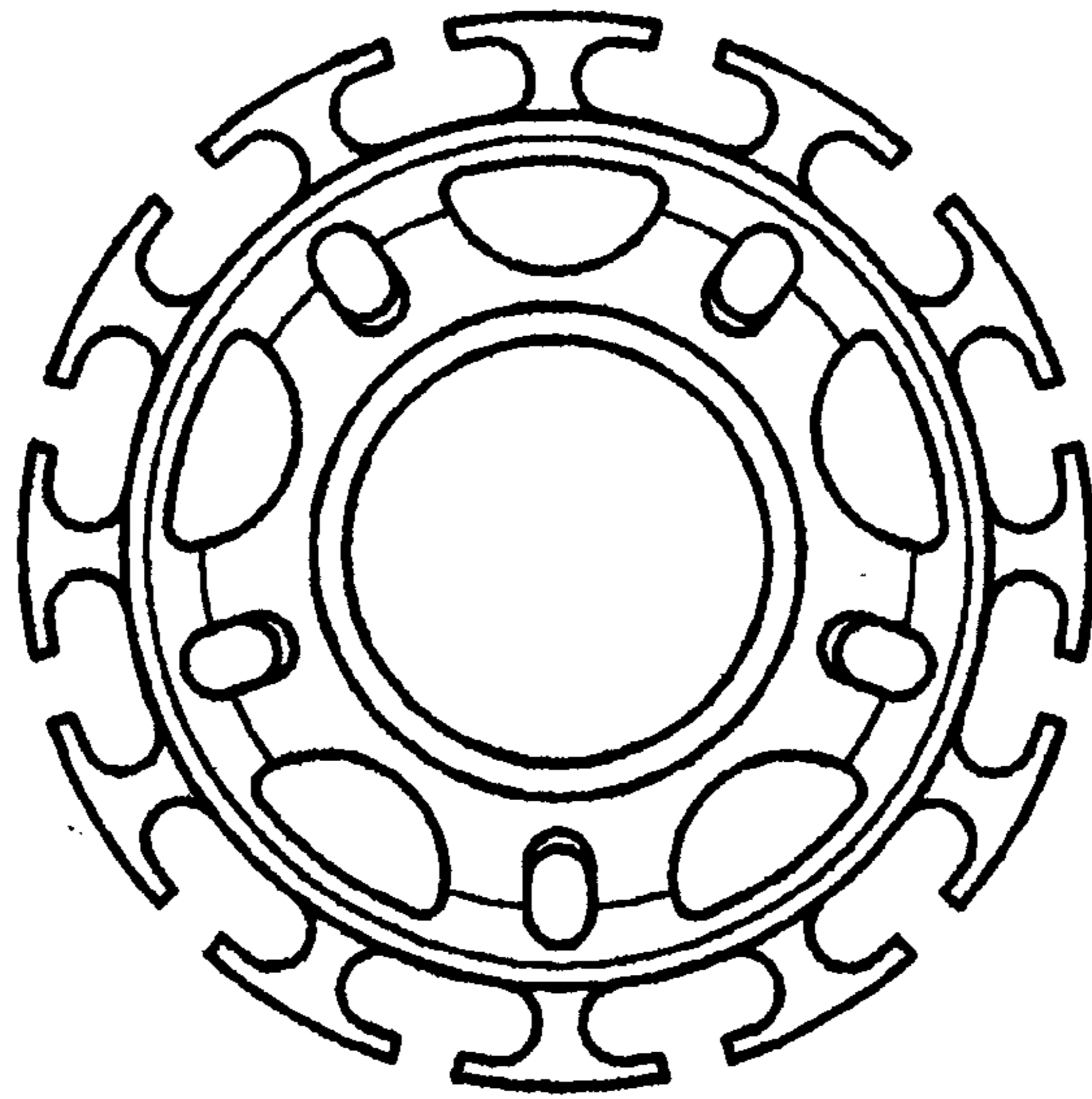

FIG. 2

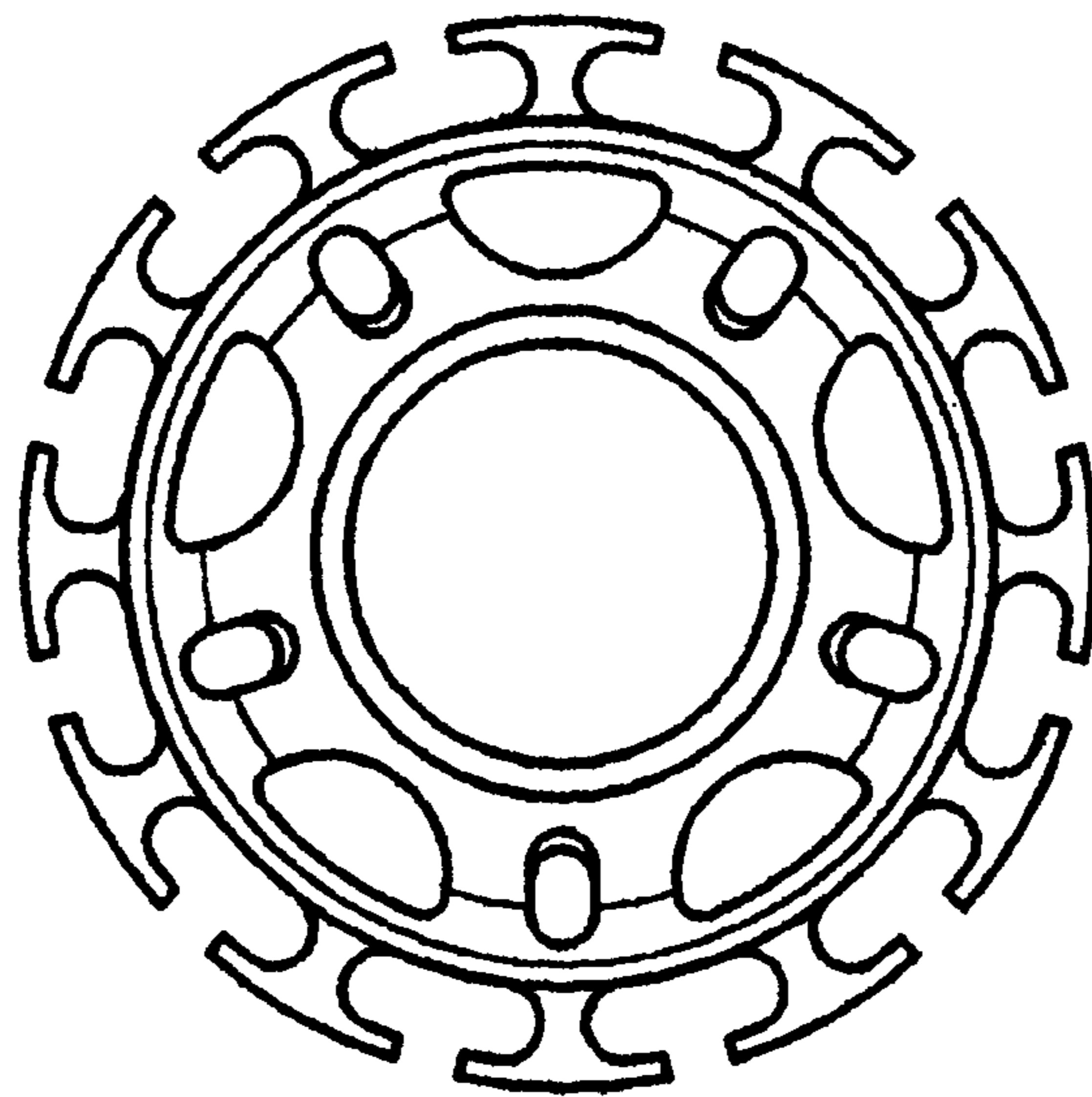

FIG. 3

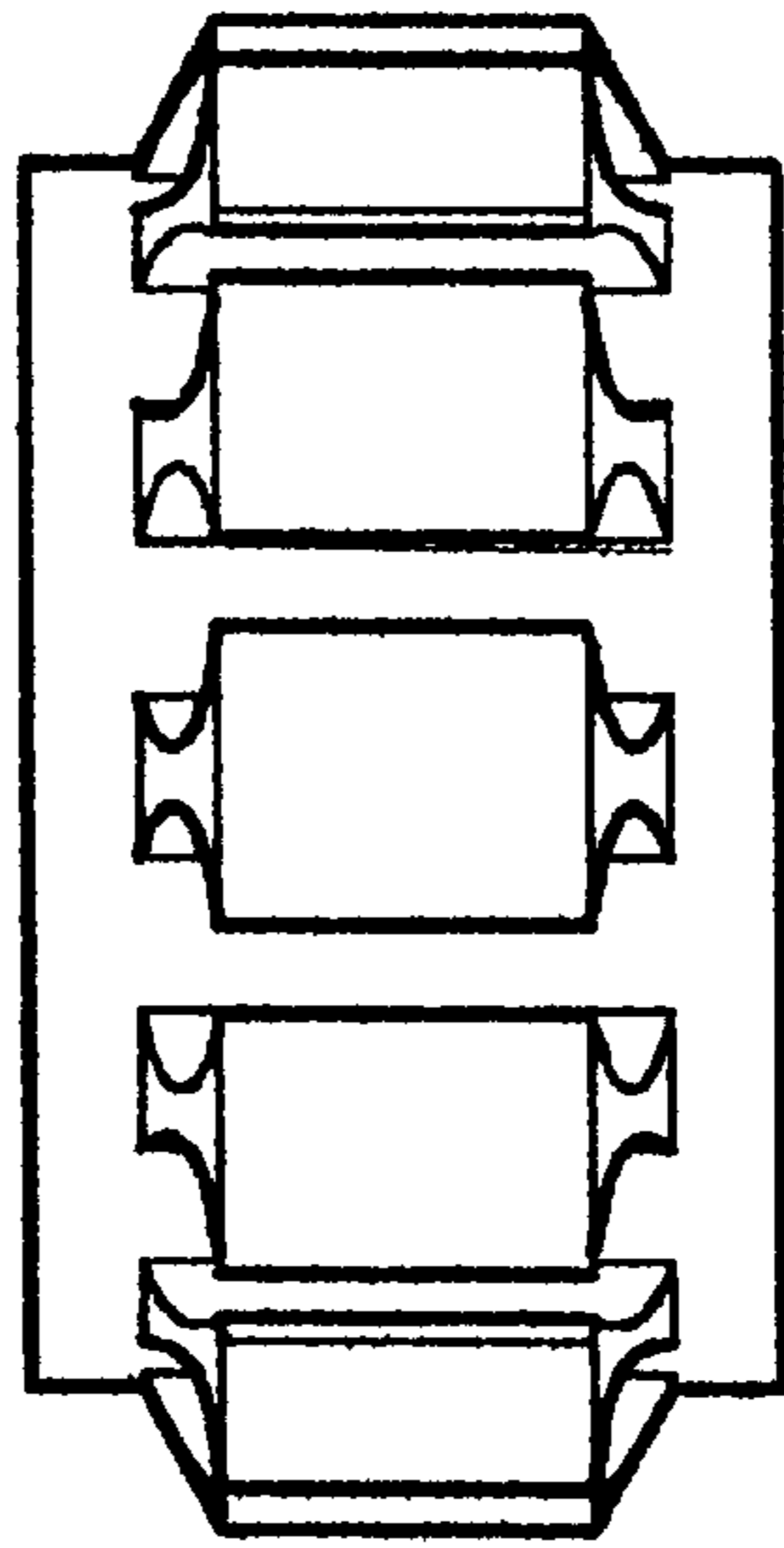

FIG. 4

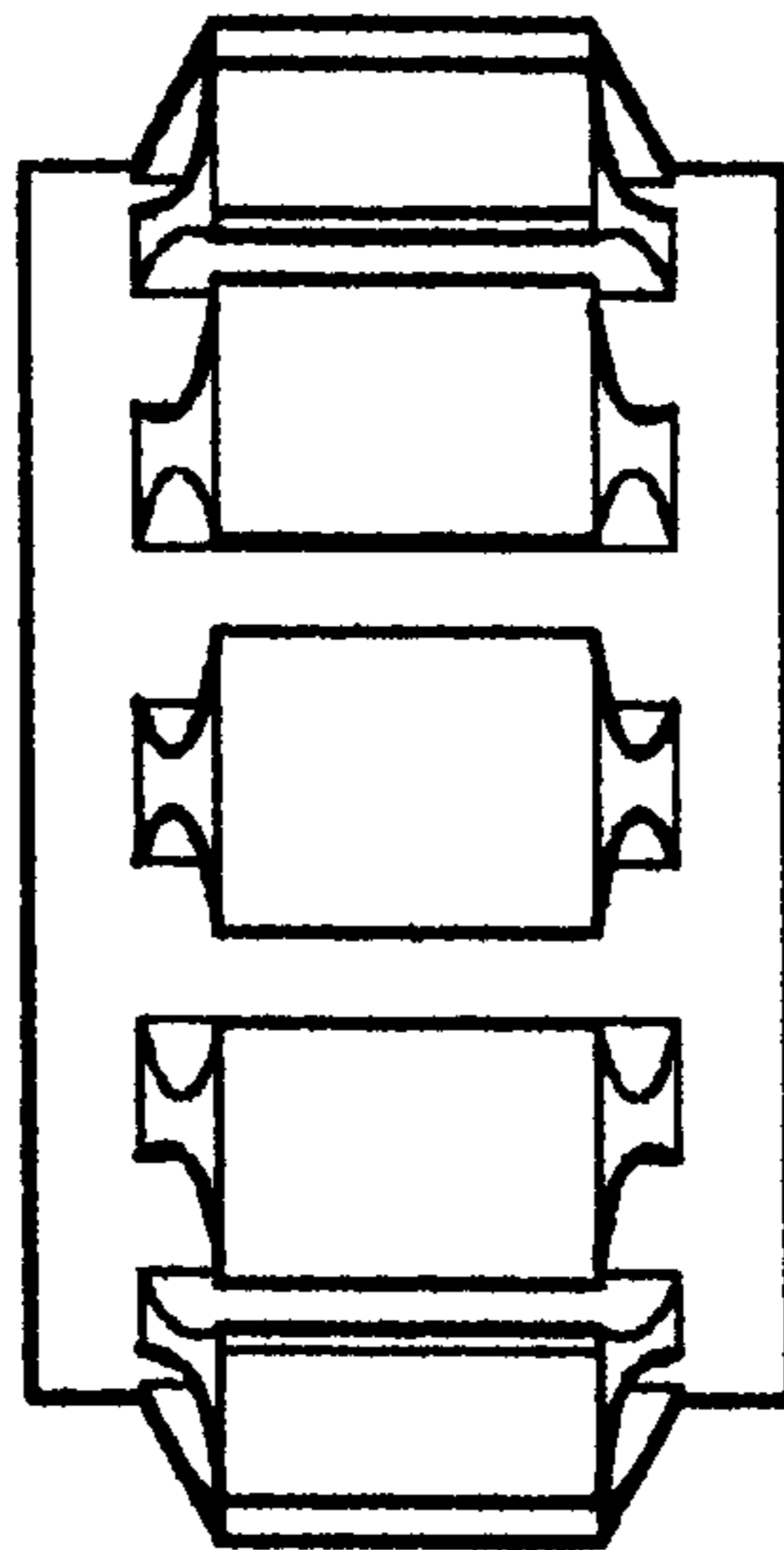

FIG. 5

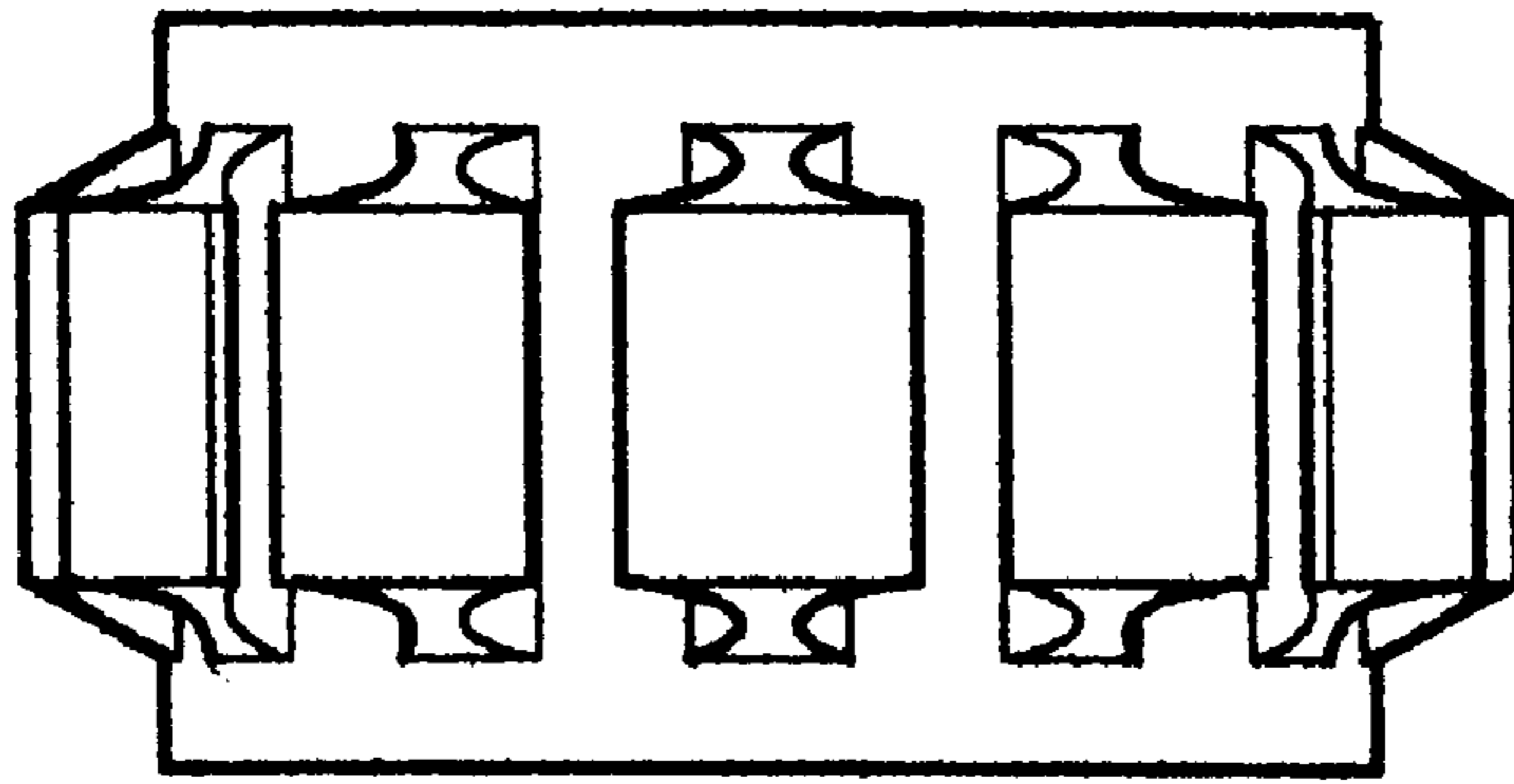

FIG. 6

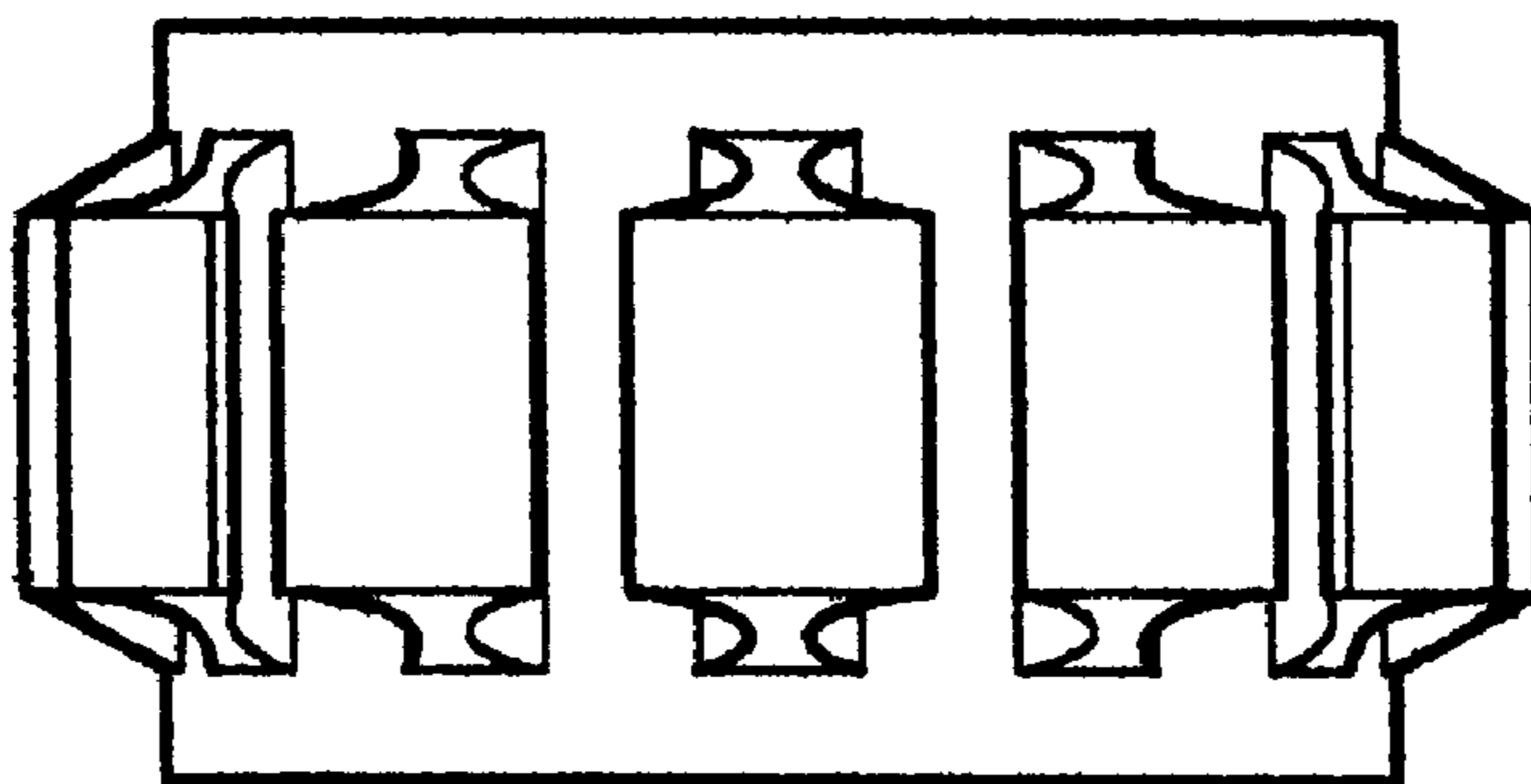

FIG. 7