



US00D433353S

United States Patent [19]

Wu et al.

[11] Patent Number: Des. 433,353

[45] Date of Patent: ** Nov. 7, 2000

[54] MOTOR VEHICLE

[75] Inventors: **Shih-Chang Wu; Julian Lao**, both of Tainan Hsien, Taiwan

[73] Assignee: **E-Ton Dynamics Technology Industry**, Tainan Hsein, Taiwan

[**] Term: **14 Years**

[21] Appl. No.: **29/110,530**

[22] Filed: **Sep. 9, 1999**

[51] LOC (7) Cl. **12-11**

[52] U.S. Cl. **D12/107**

[58] Field of Search D12/107, 3; 120/233, 120/311, 312, 225, 229, 315

[56] **References Cited**

U.S. PATENT DOCUMENTS

D. 299,707 2/1989 Makita et al. D12/107

D. 327,457 6/1992 Saito D12/107
D. 330,694 11/1992 Kimura et al. D12/107
D. 412,464 8/1999 Ichihara et al. D12/107

Primary Examiner—Melody N. Brown
Attorney, Agent, or Firm—Dickinson Wright PLLC

[57] **CLAIM**

The ornamental design for a motor vehicle, as shown and described.

DESCRIPTION

FIG. 1 is a perspective view of motor vehicle showing my new design;
FIG. 2 is a front elevational view thereof;
FIG. 3 is a rear elevational view thereof;
FIG. 4 is a left side elevational view thereof;
FIG. 5 is a right side elevational view thereof; and,
FIG. 6 is a top plan view thereof.

1 Claim, 6 Drawing Sheets

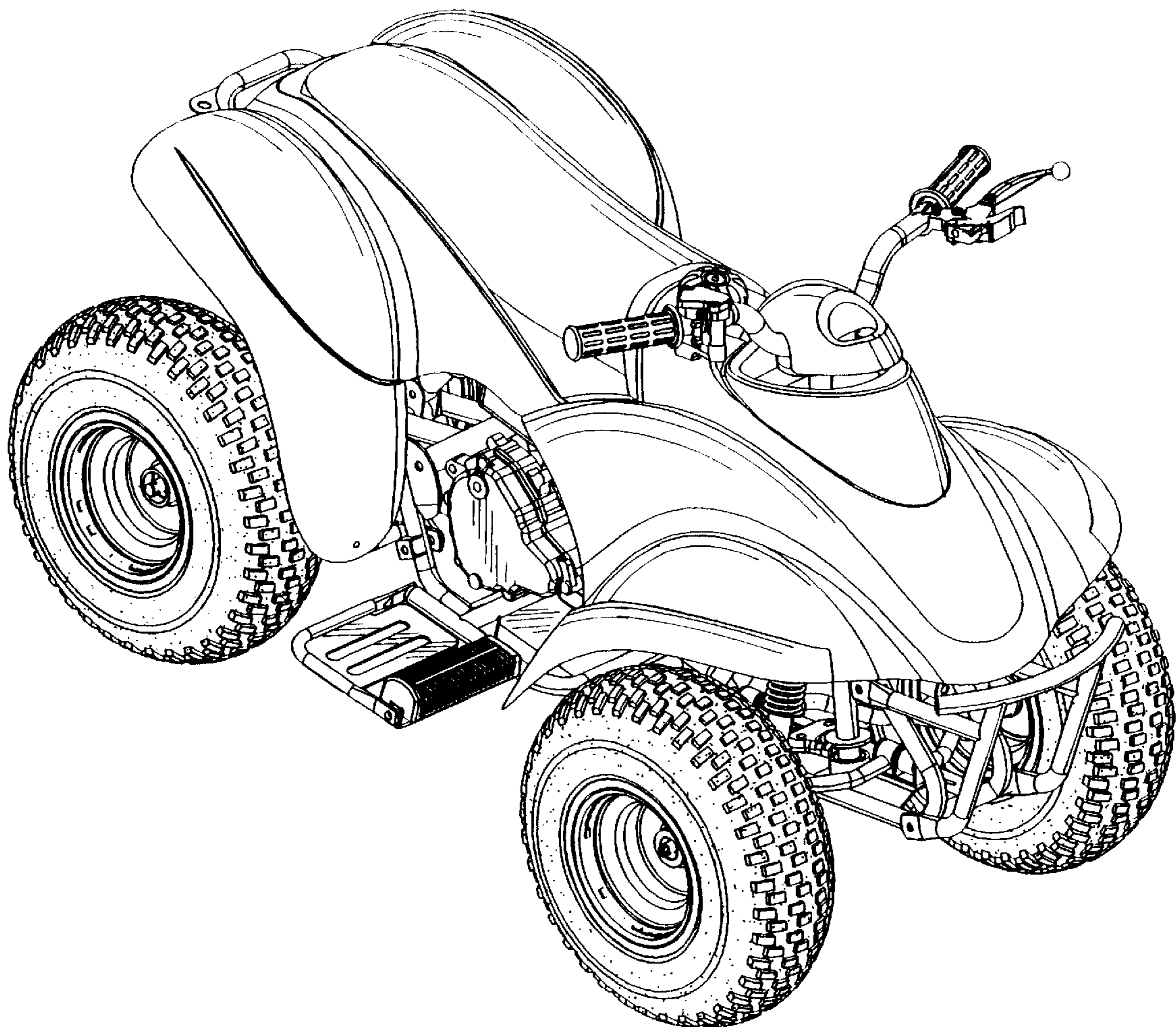

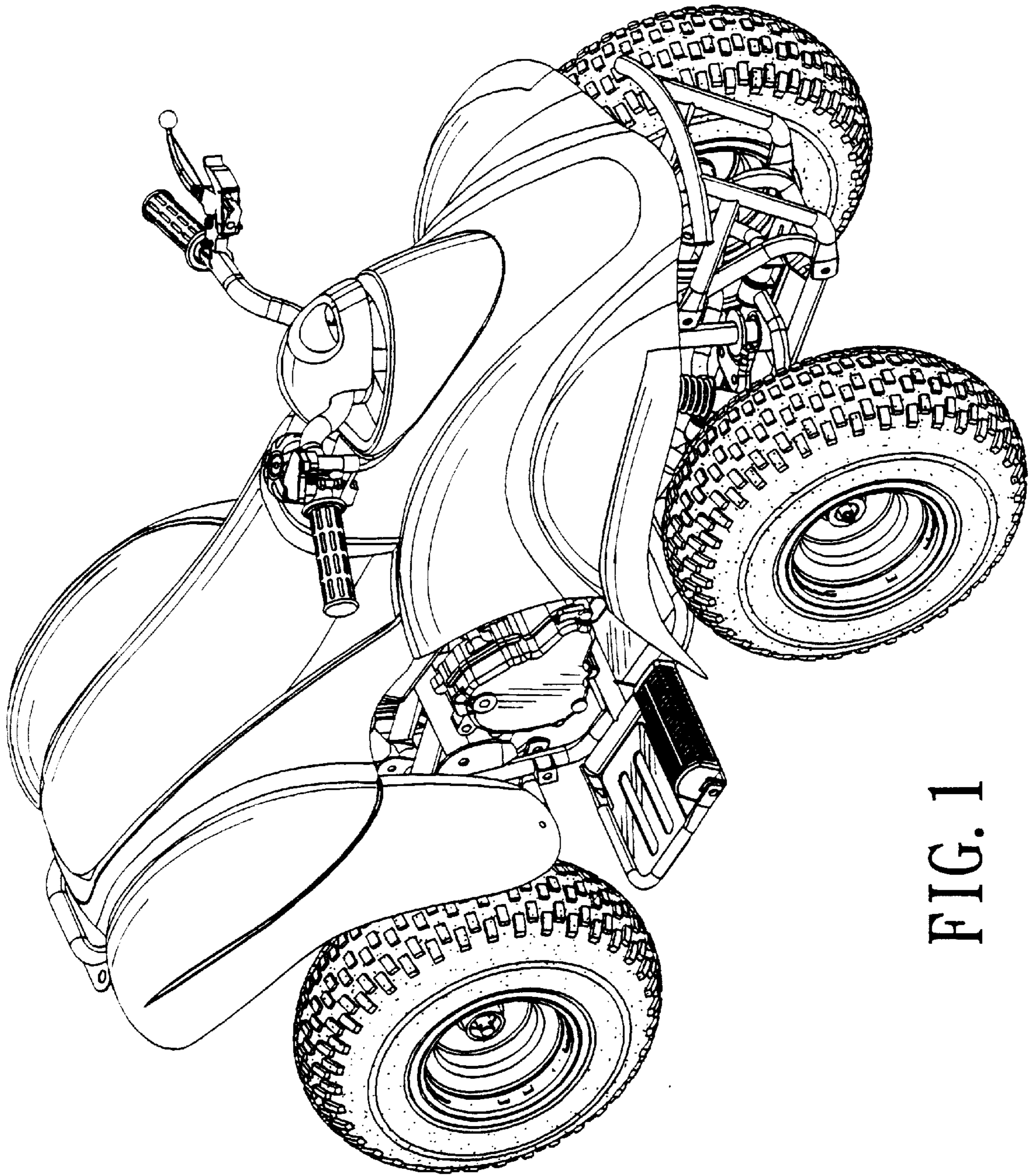

FIG. 1

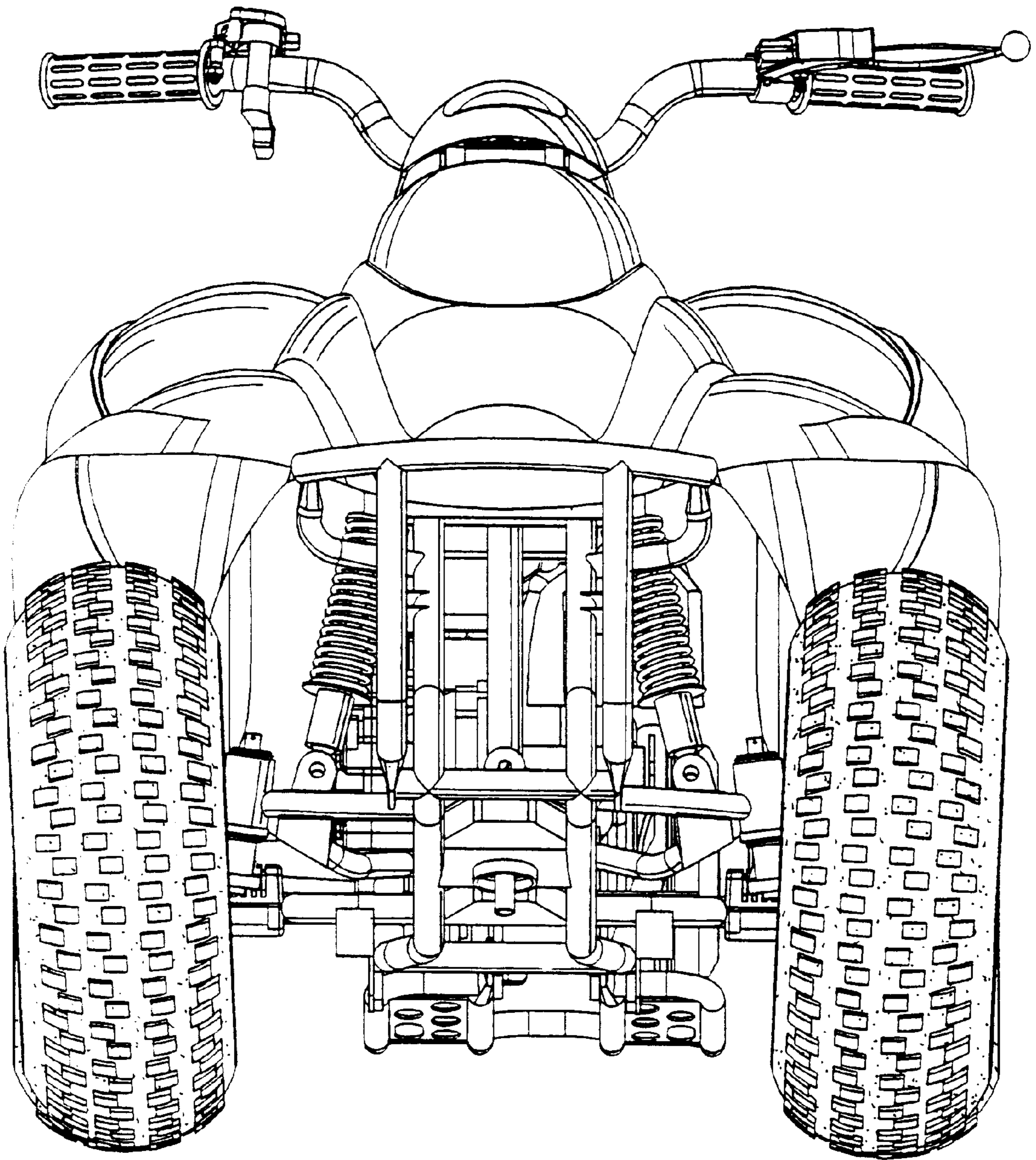

FIG. 2

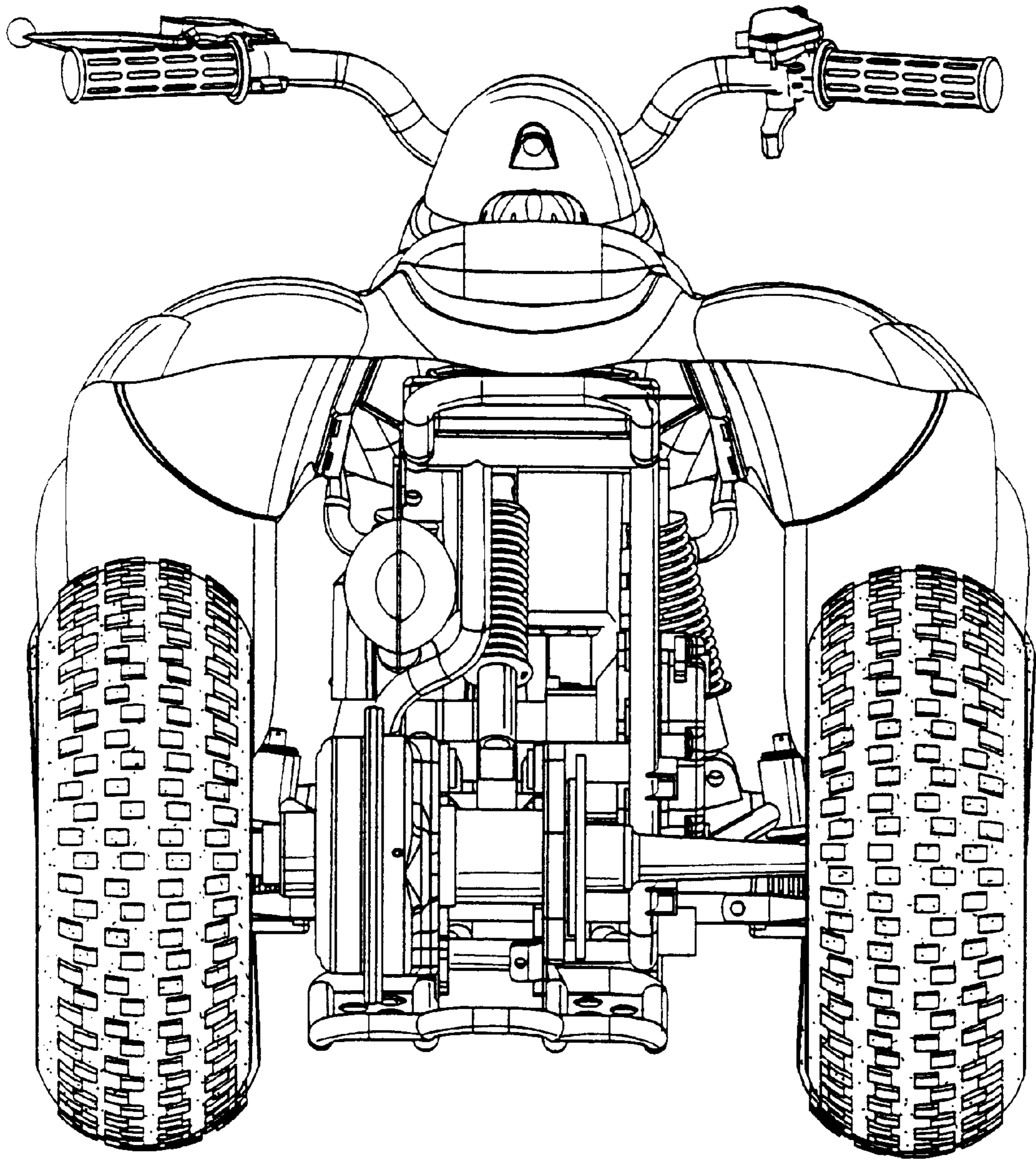

FIG. 3

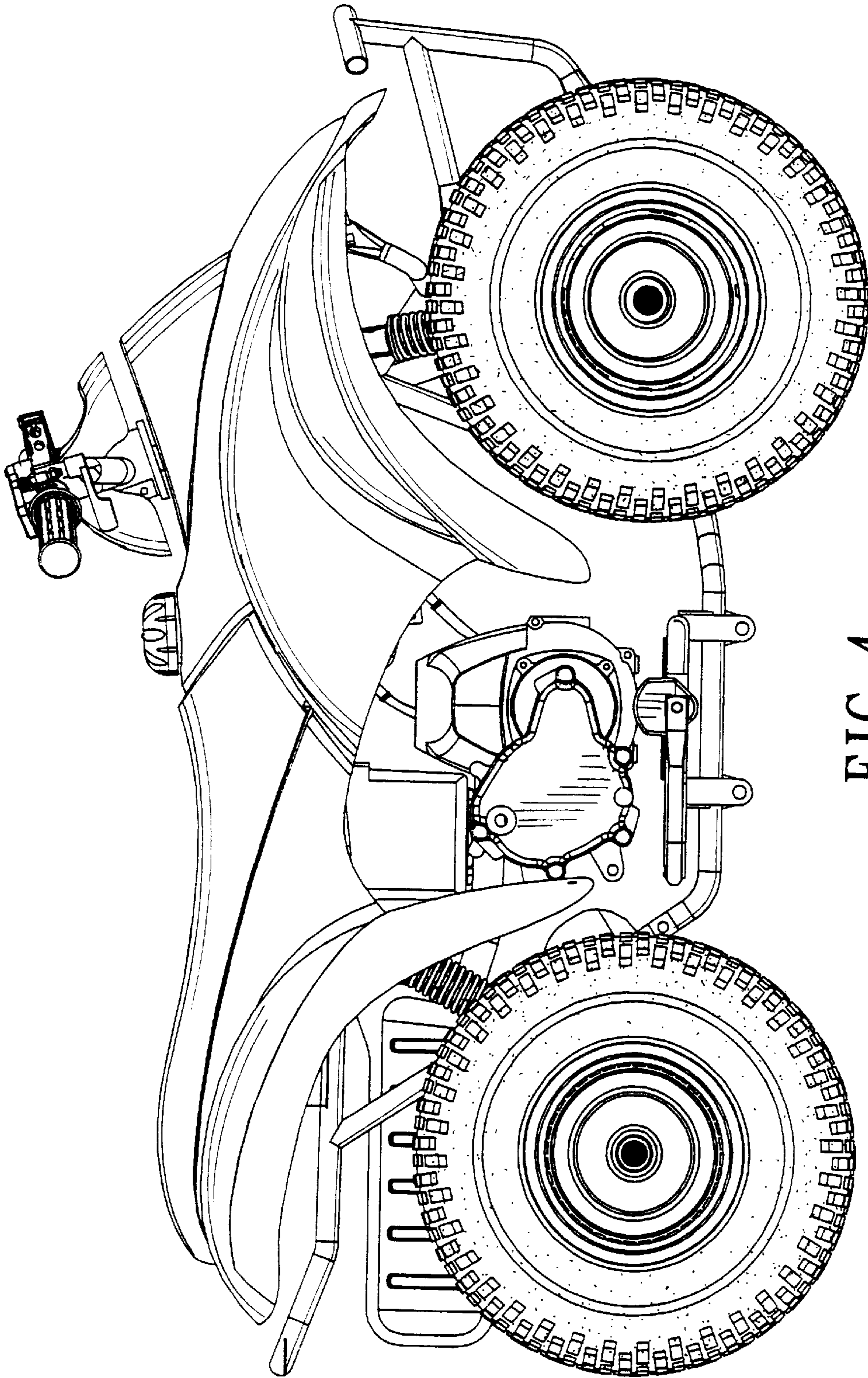

FIG. 4

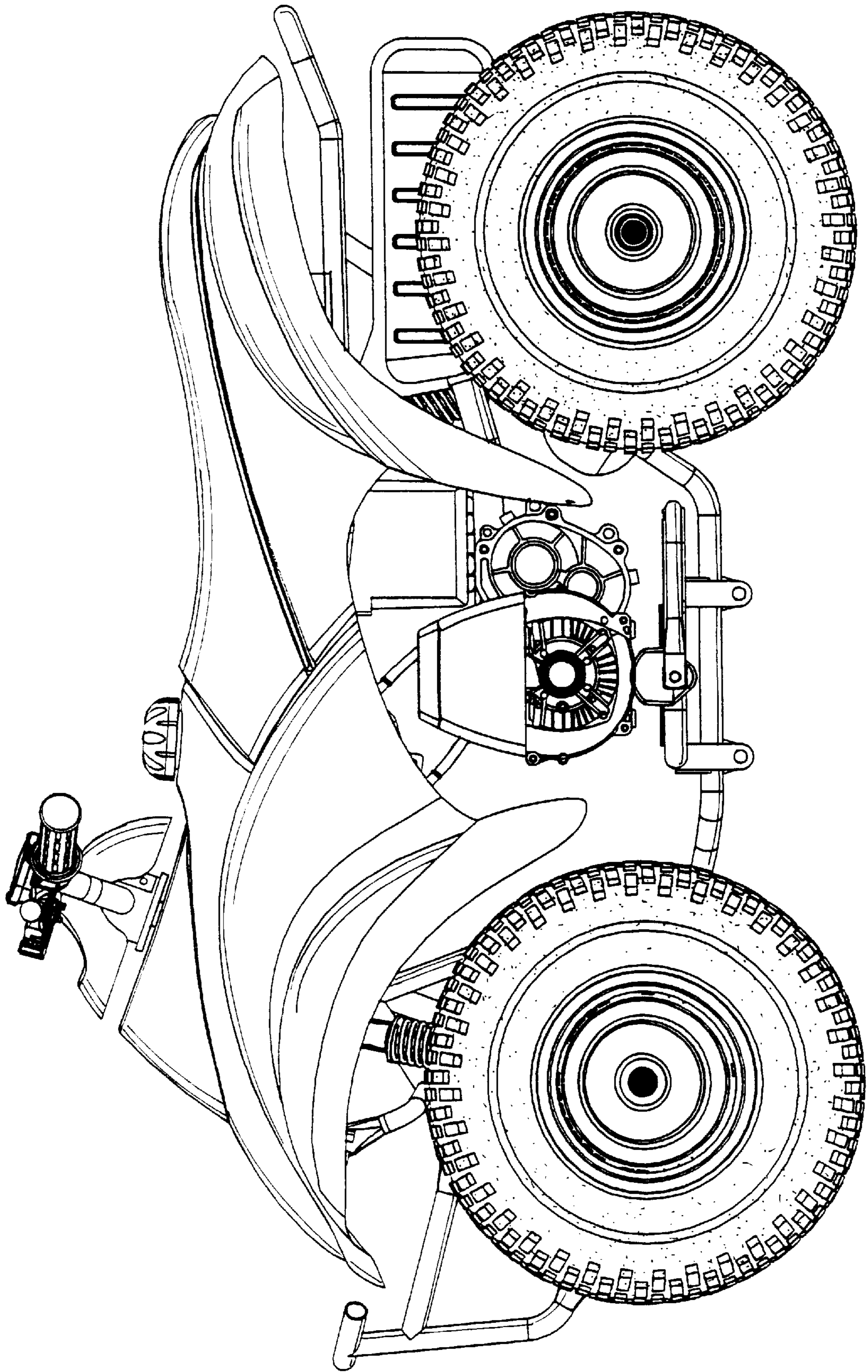

FIG. 5

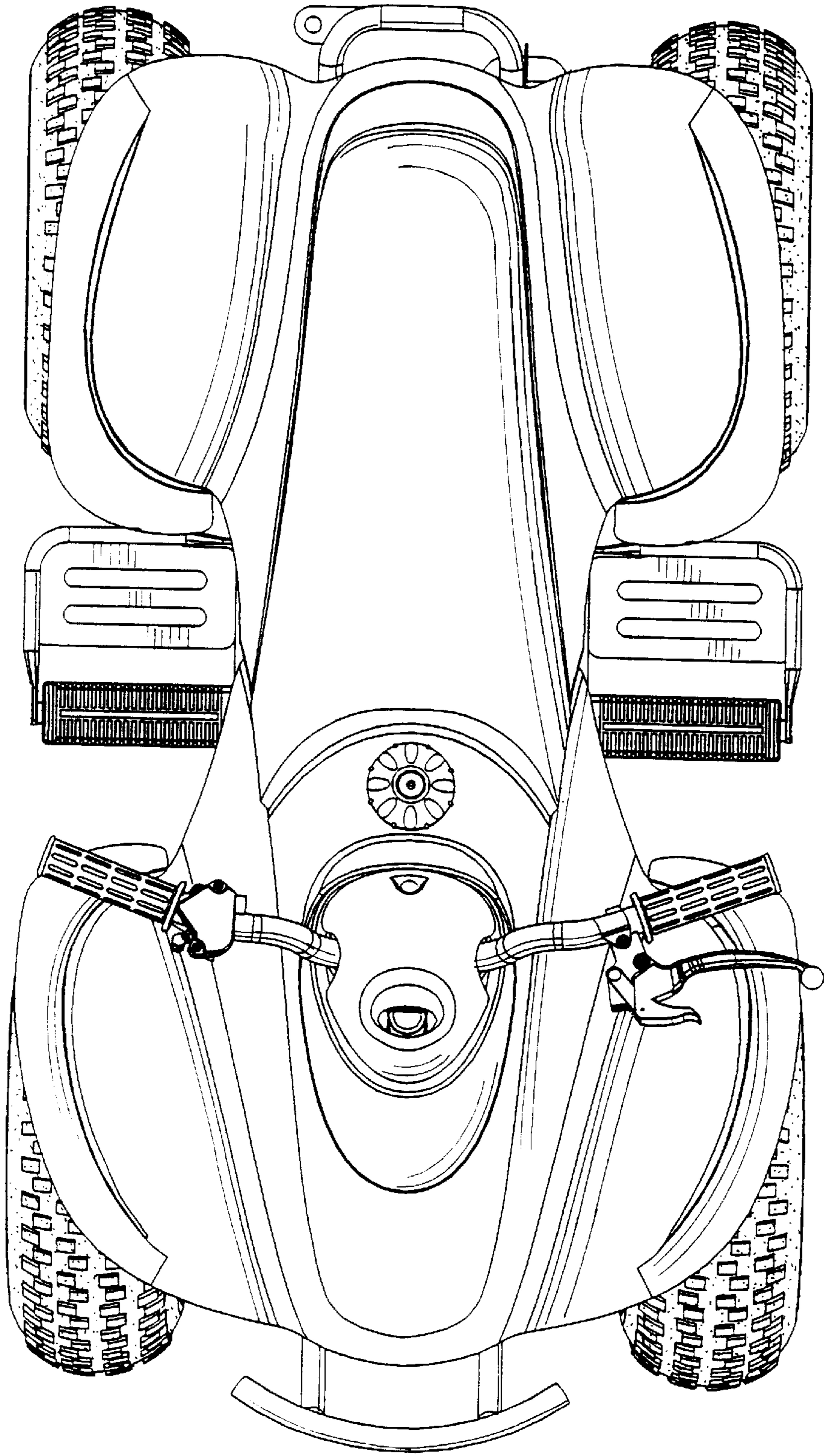

FIG. 6