



US00D433346S

United States Patent [19]

[11] Patent Number: Des. 433,346

Evans et al.

[45] Date of Patent: ** Nov. 7, 2000

[54] PORTABLE AUTOMOTIVE AIR CONDITIONING SERVICE UNIT

[75] Inventors: **Mike S. Evans**, Pioneer; **Harold E. Lyons**, Bryan, both of Ohio; **Howard S. Ryan**, Skaneateles, N.Y.

[73] Assignee: **SPX Corporation**, Muskegon, Mich.

[**] Term: **14 Years**

[21] Appl. No.: **29/113,146**

[22] Filed: **Oct. 29, 1999**

[51] **LOC (7) Cl.** **10-04**

[52] **U.S. Cl.** **D10/75; D10/46**

[58] **Field of Search** D10/46, 75; 73/117.3, 73/118.1; 324/384, 379; 364/468.15, 468.17, 468.2

[56] References Cited

U.S. PATENT DOCUMENTS

- D. 329,390 9/1992 Alfonso et al. D10/75
- D. 342,909 1/1994 Marchals D10/75

Primary Examiner—Antoine Duval Davis
Attorney, Agent, or Firm—Hovey, Williams, Timmons & Collins

[57] CLAIM

The ornamental design for a portable automotive air conditioning service unit, as shown and described.

DESCRIPTION

FIG. 1 is a front perspective view of the portable automotive air conditioning service unit;
 FIG. 2 is a rear perspective view of the portable automotive air conditioning service unit of FIG. 1;
 FIG. 3 is a front elevational view of the portable automotive air conditioning service unit of FIG. 1;
 FIG. 4 is a side elevational view of the portable automotive air conditioning service unit of FIG. 1;
 FIG. 5 is an opposite side elevational view of the portable automotive air conditioning service unit of FIG. 1;
 FIG. 6 is a rear elevational view of the portable automotive air conditioning service unit of FIG. 1;
 FIG. 7 is a top plan view of the portable automotive air conditioning service unit of FIG. 1;
 FIG. 8 is a bottom plan view of the portable automotive air conditioning service unit of FIG. 1;
 FIG. 9 is a top plan view of an alternate portable automotive air conditioning service unit;
 FIG. 10 is a front perspective view of the portable automotive air conditioning service unit of FIG. 9, and,
 FIG. 11 is a front elevational view of the portable automotive air conditioning service unit of FIG. 9.
 All features and views not shown in solid lines in FIGS. 9–10 are identical to those shown in the first embodiment with the exception of the broken line disclosure.
 The broken line showing is for illustrative purposes only and forms no part of the claimed design.

1 Claim, 5 Drawing Sheets

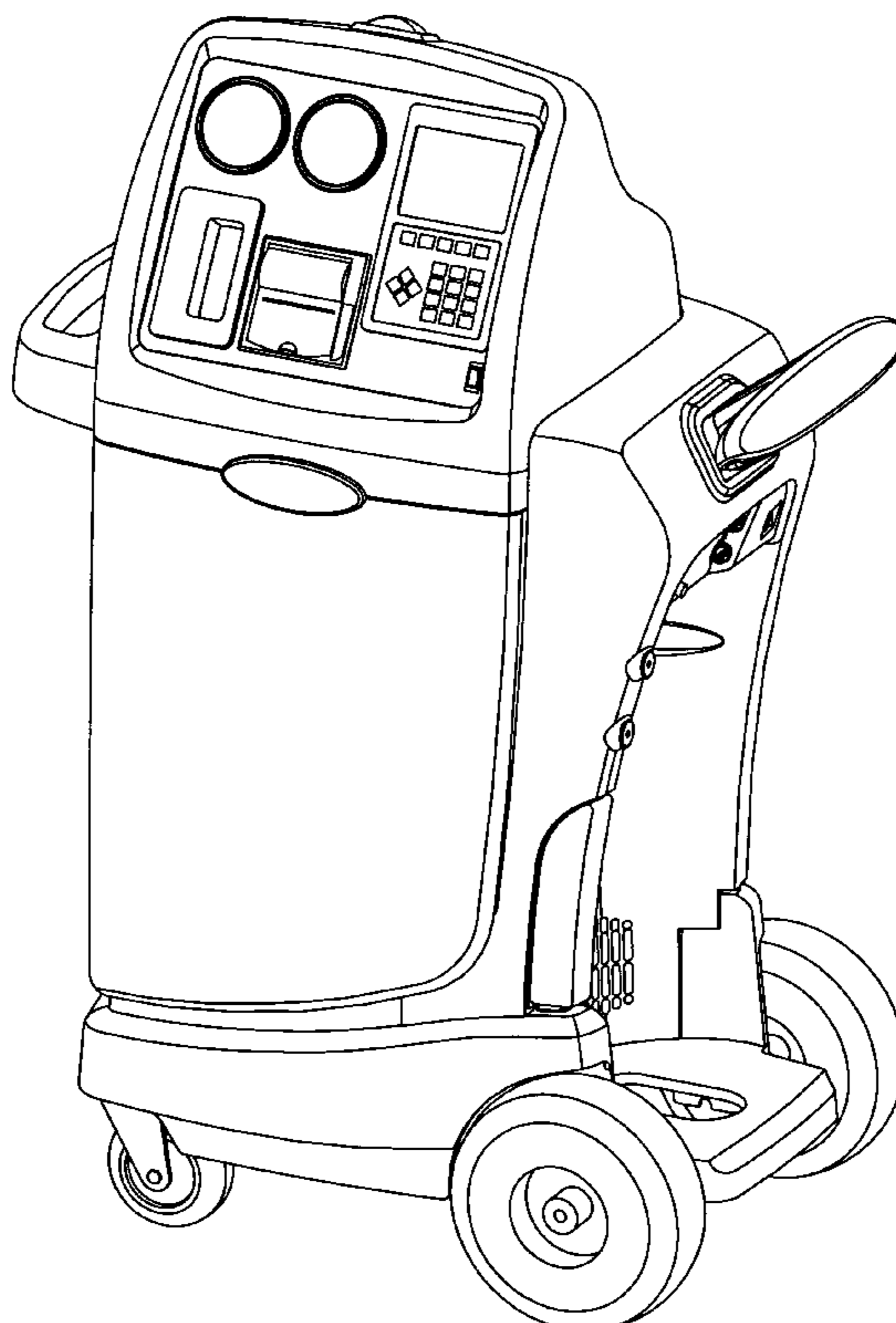

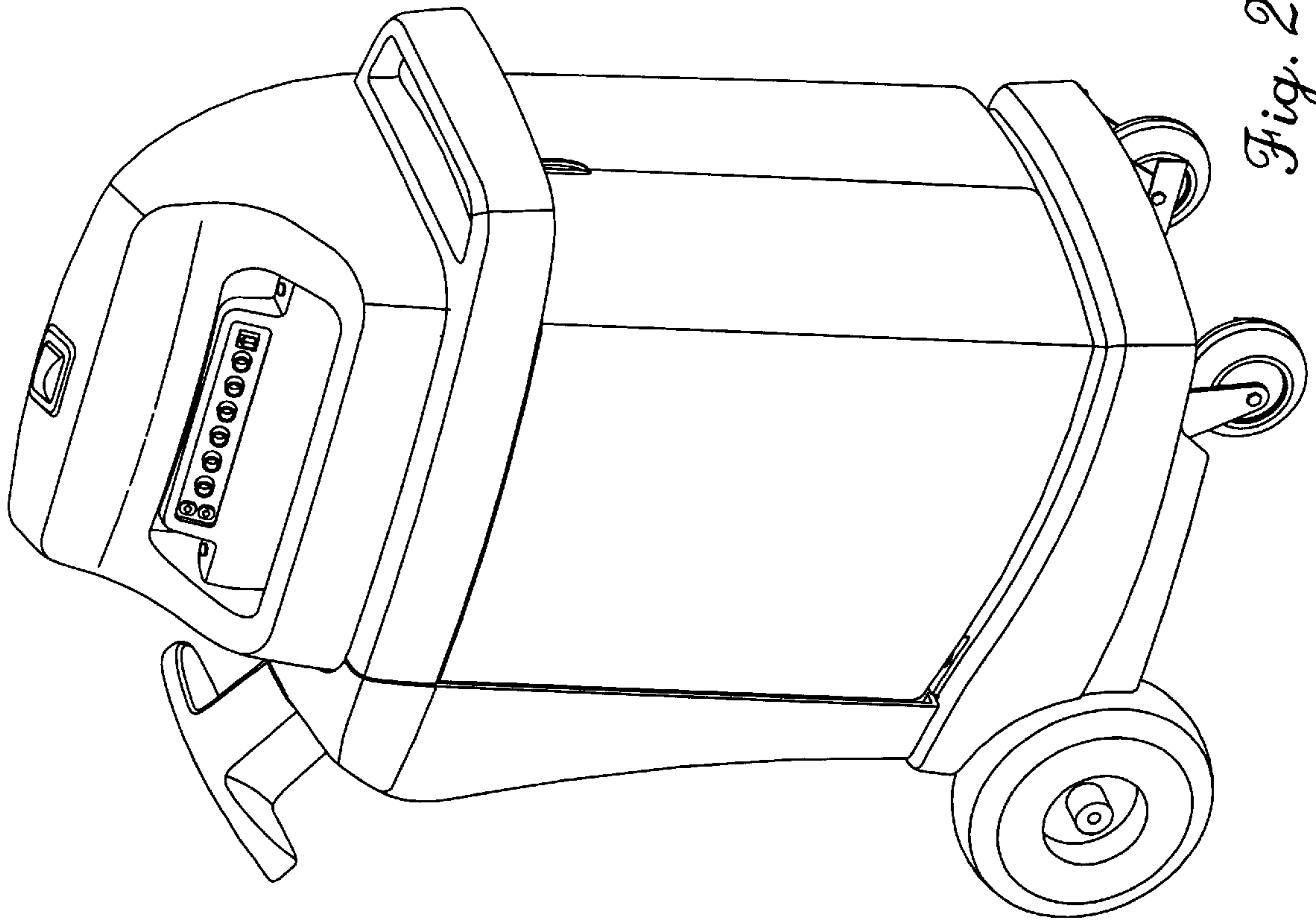

Fig. 2.

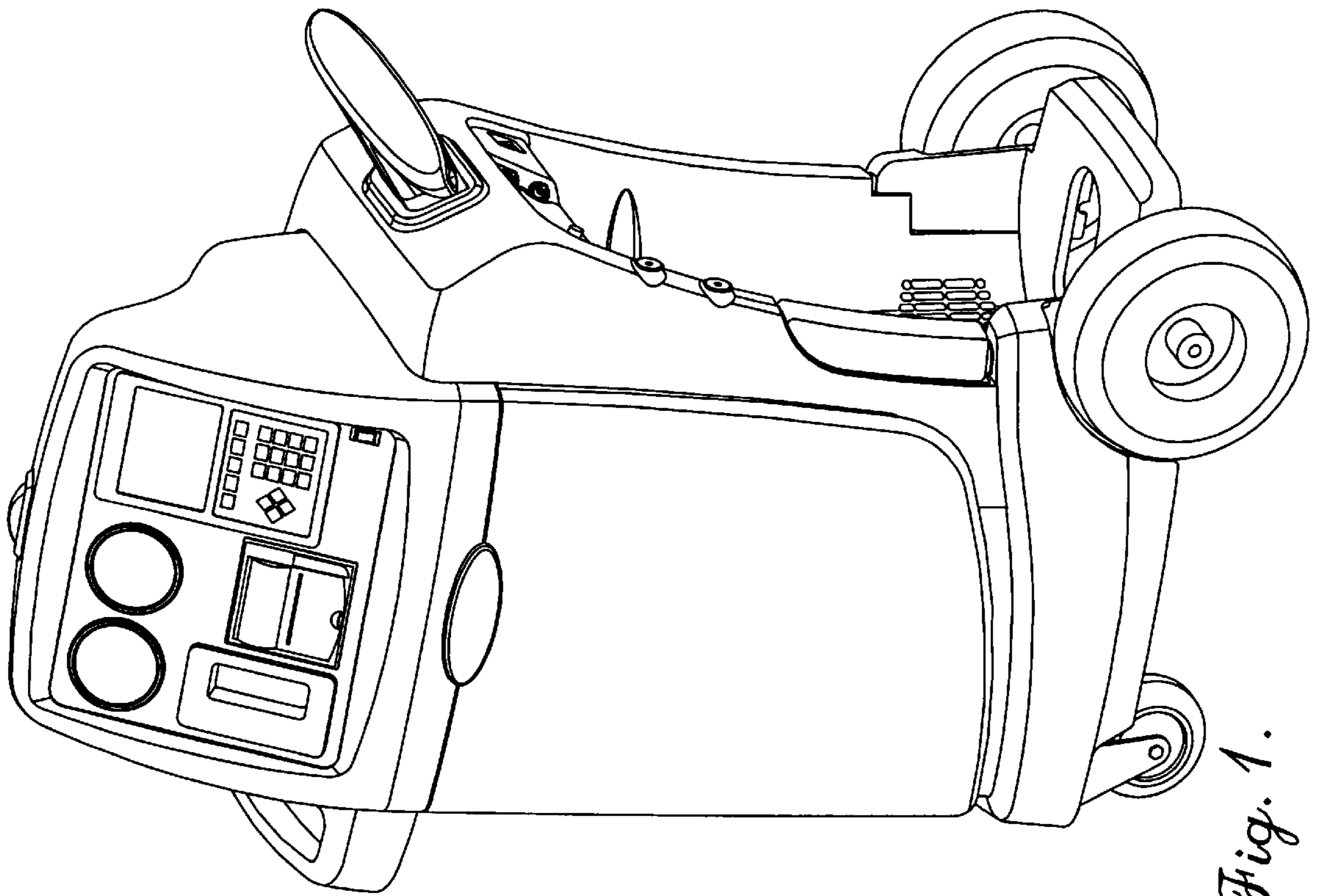

Fig. 1.

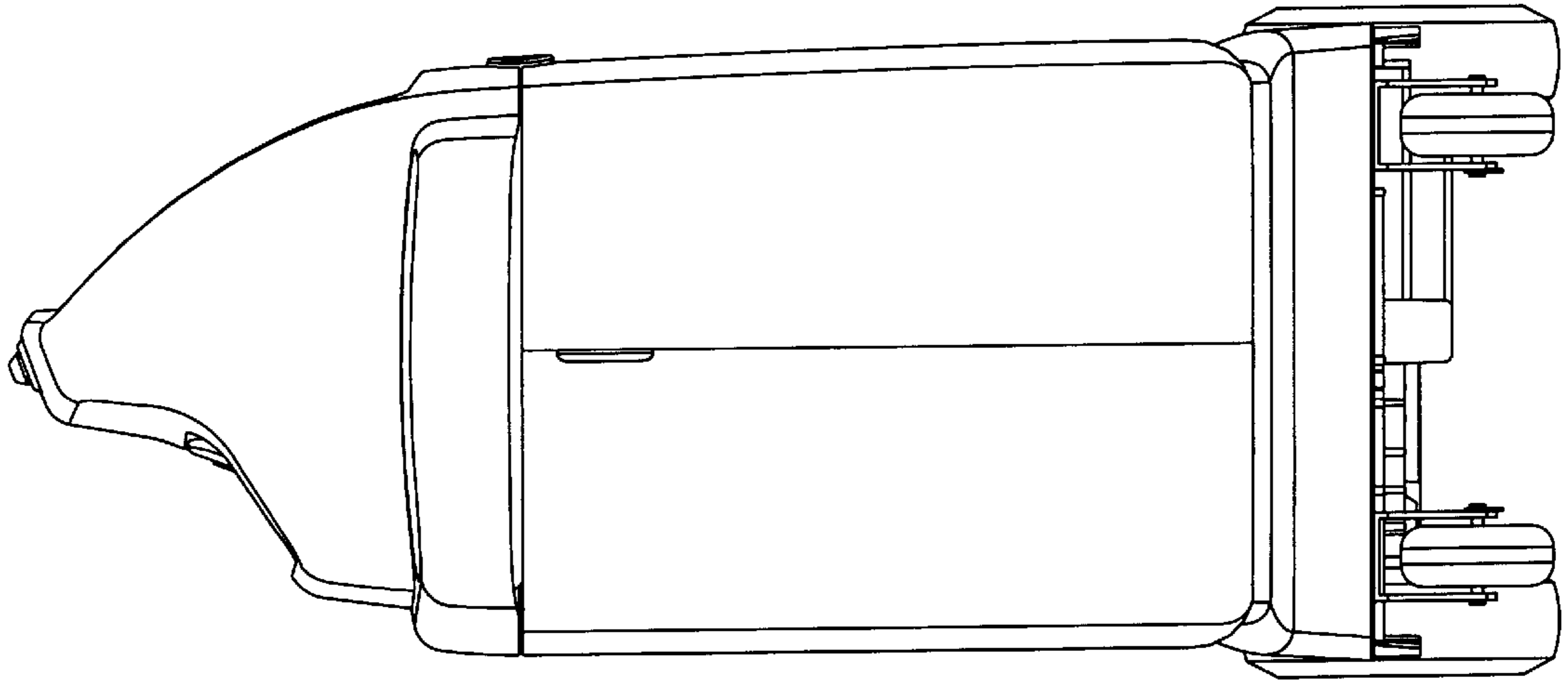

Fig. 4.

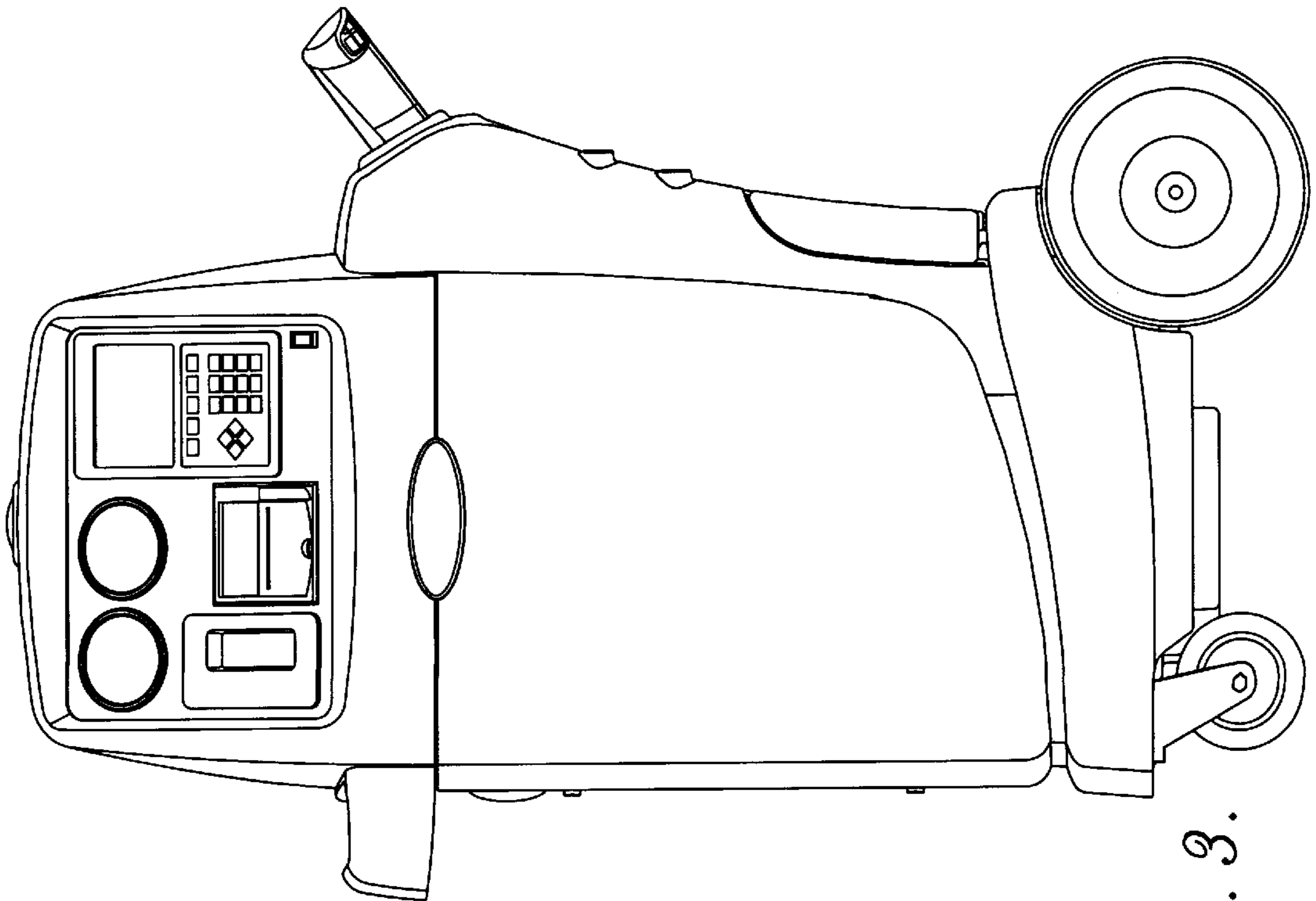

Fig. 3.

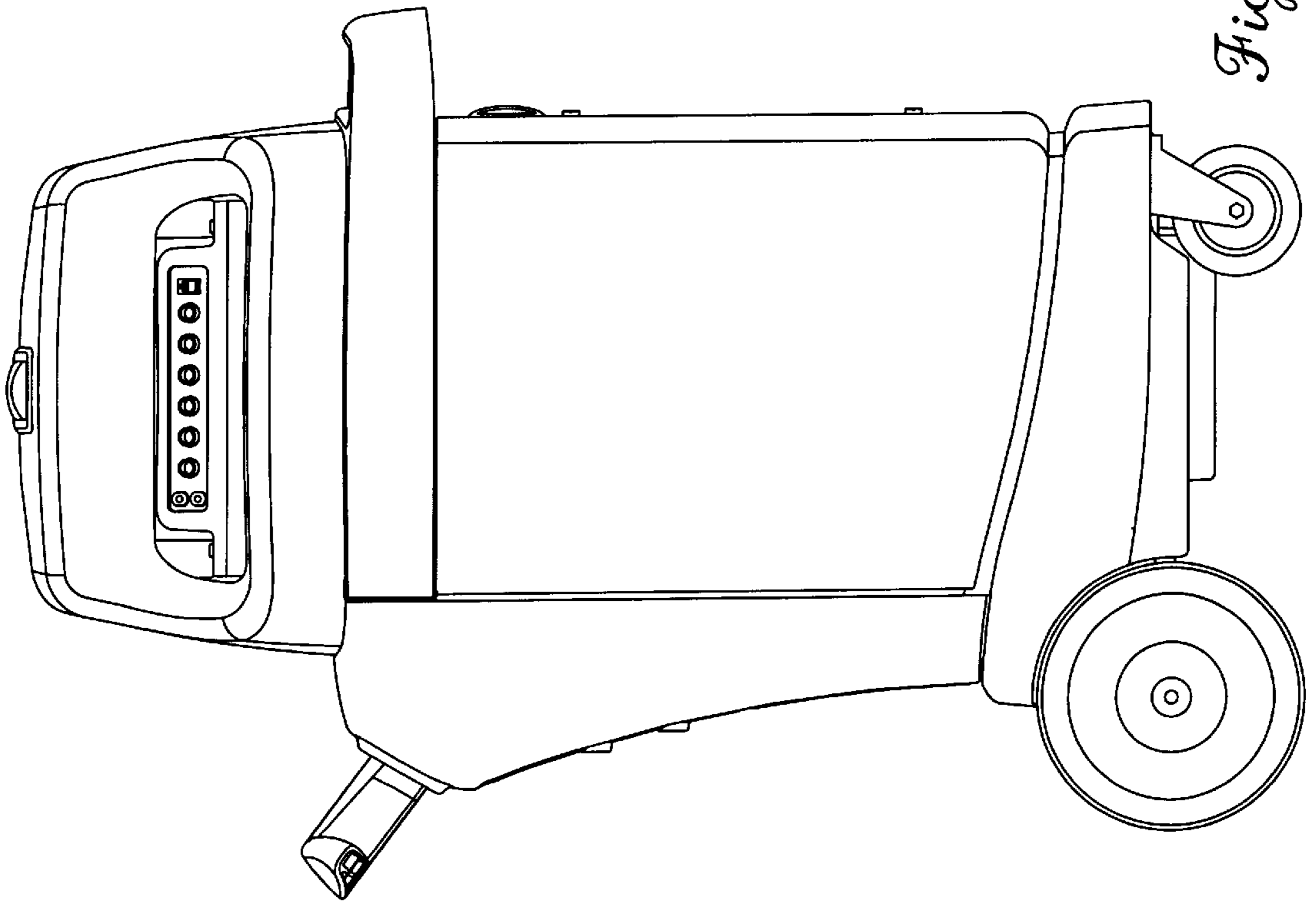

Fig. 6.

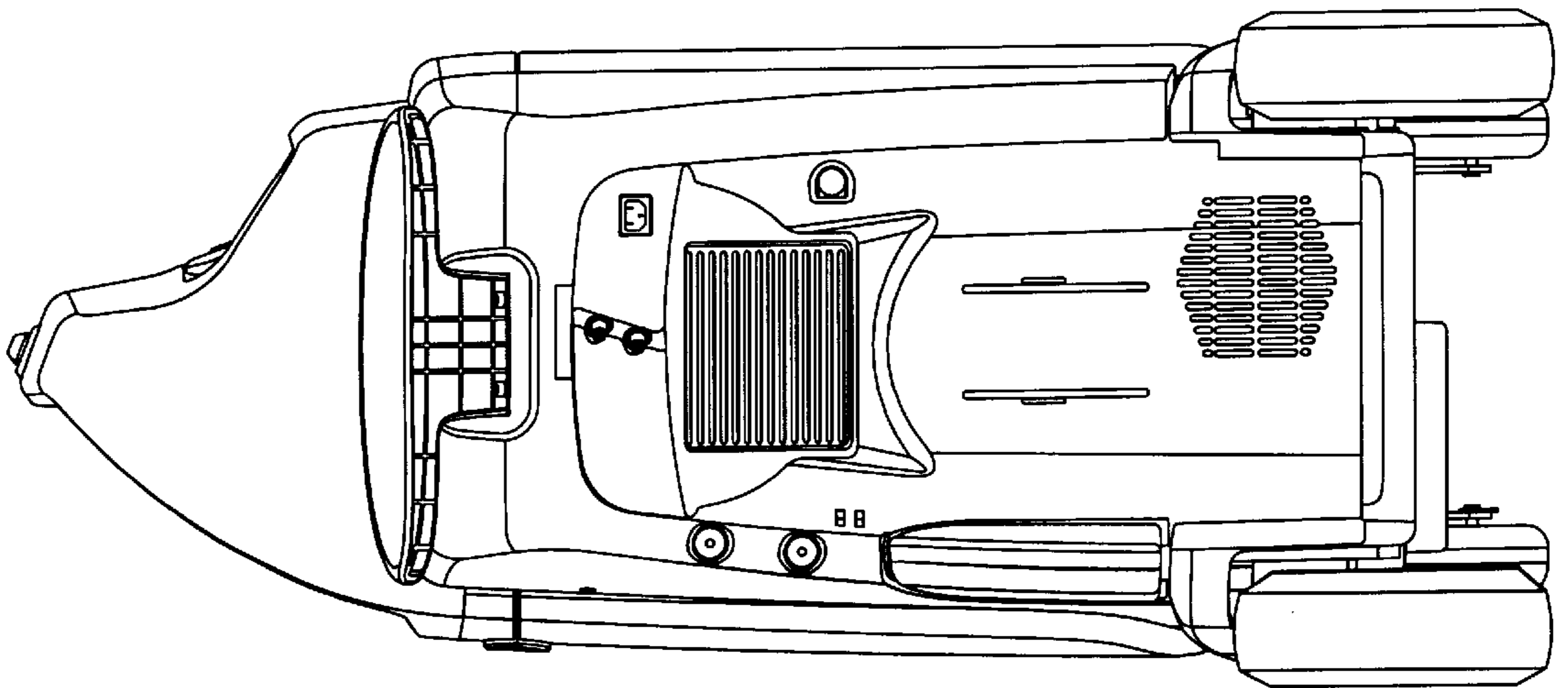

Fig. 5.

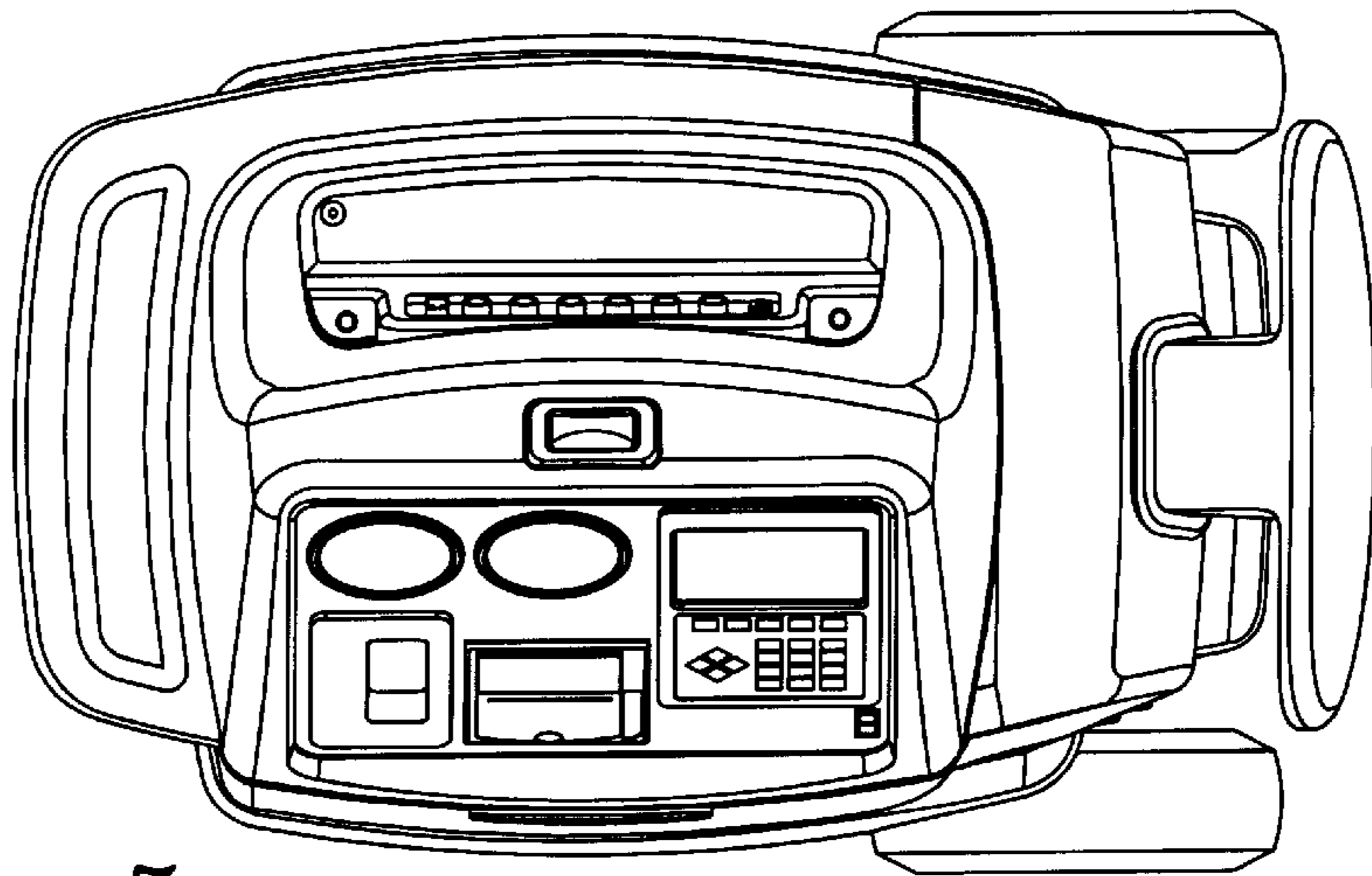

Fig. 7.

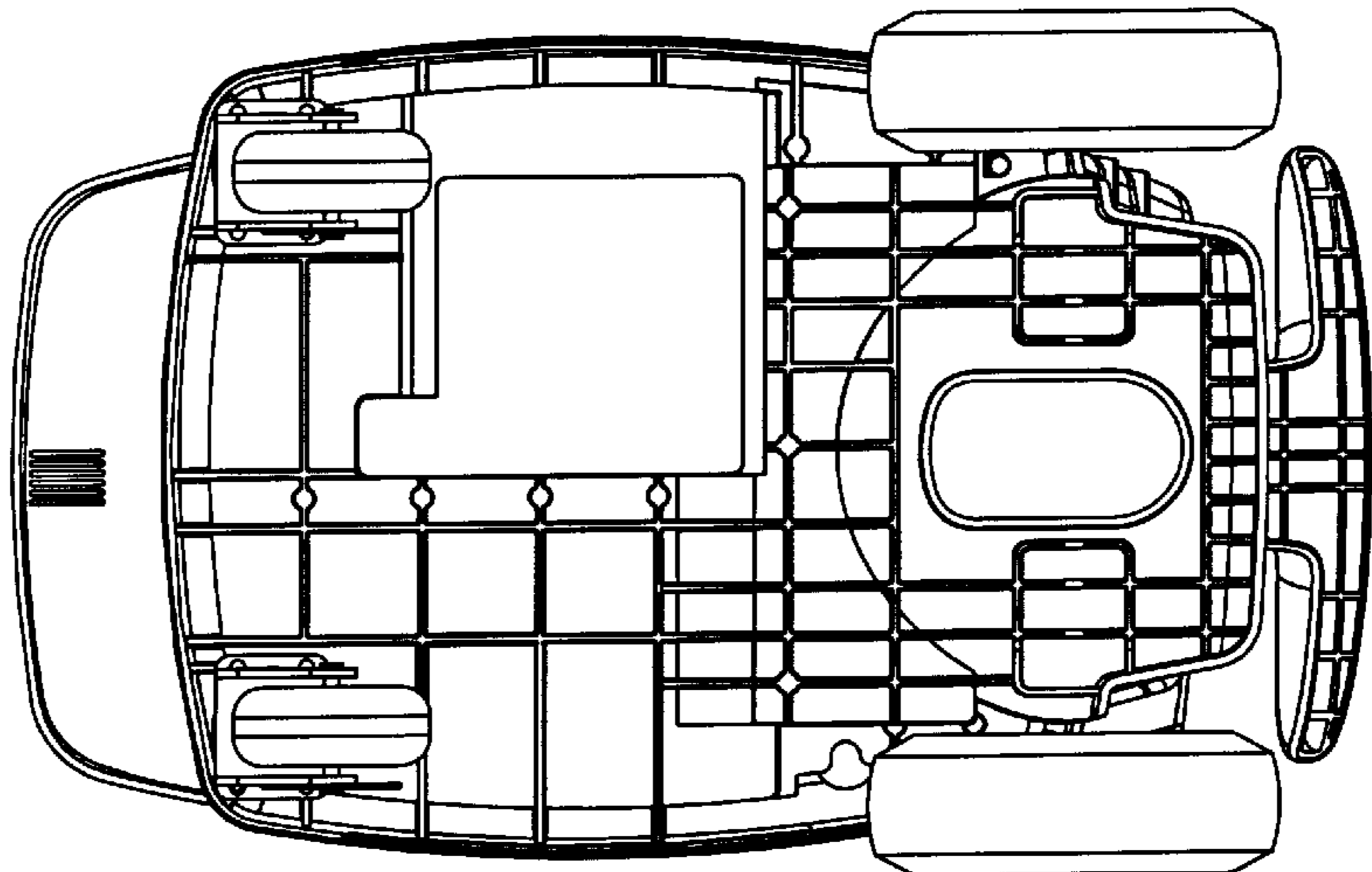

Fig. 8.

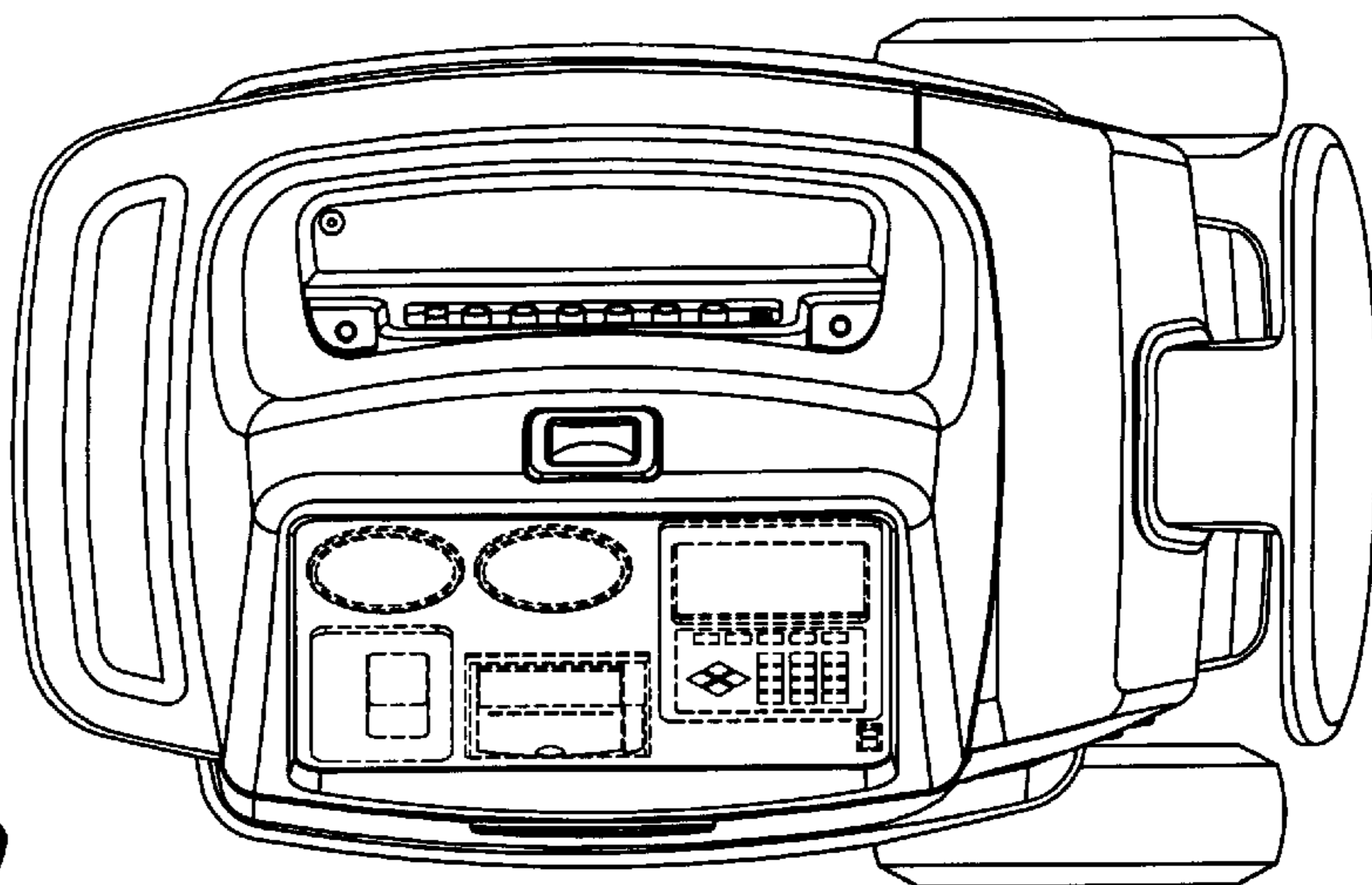

Fig. 9.

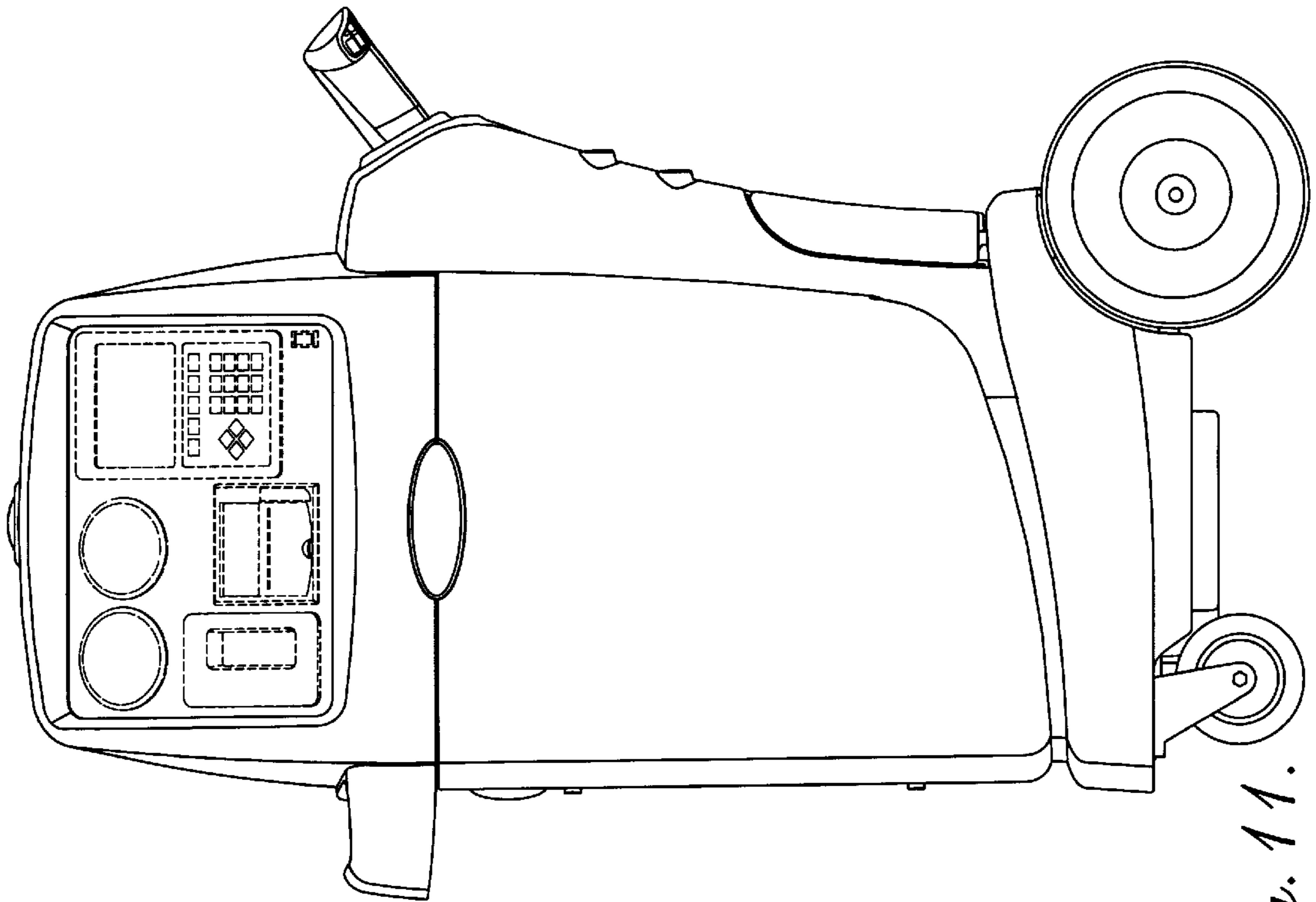

Fig. 11.

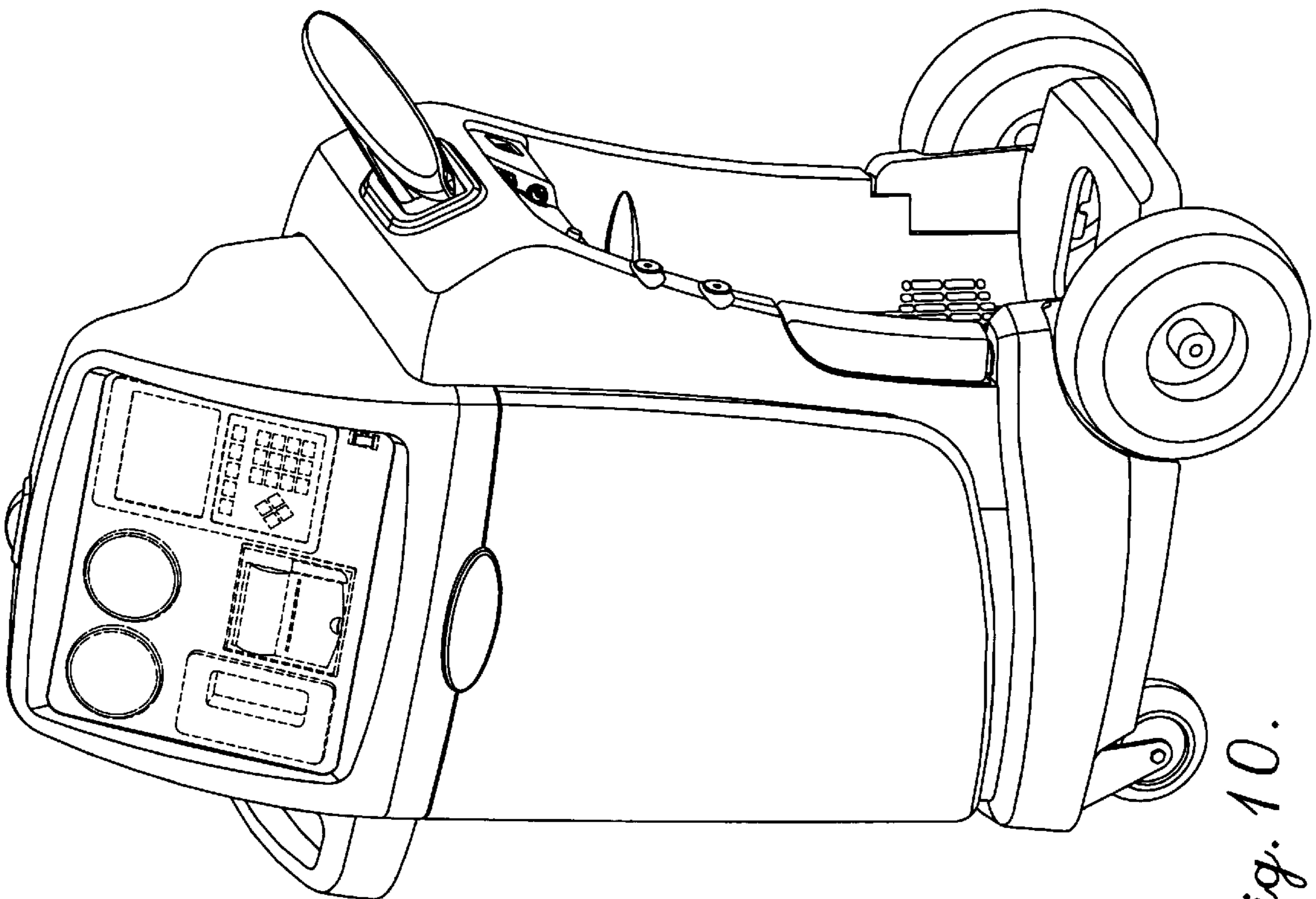

Fig. 10.