



US00D433029S

United States Patent [19] Eidson

[11] **Patent Number: Des. 433,029**

[45] **Date of Patent: ** Oct. 31, 2000**

[54] **JET ENGINE INTAKE DEFLECTION GUARD**

[76] Inventor: **Ross Eidson**, HCR 80 Box 10,
Camdenton, Mo. 65020

[**] Term: **14 Years**

[21] Appl. No.: **29/106,181**

[22] Filed: **Jun. 10, 1999**

[51] **LOC (7) Cl.** **15-01**

[52] **U.S. Cl.** **D15/5**

[58] **Field of Search** D15/1, 5; 244/53 B;
60/39.092, 268; 55/306

4,796,424 1/1989 Farrar et al. .
4,833,879 5/1989 Verduyn et al. .
5,411,224 5/1995 Dearmon et al. 244/530

Primary Examiner—Ralf Siefert
Attorney, Agent, or Firm—John D. Gugliotta

[57] CLAIM

The ornamental design for a jet engine intake deflection guard, as shown and described.

DESCRIPTION

FIG. 1 is a perspective view of a jet engine intake deflection guard showing my new design;
FIG. 2 is a top plan view thereof;
FIG. 3 is a bottom plan view thereof;
FIG. 4 is a front elevational view thereof;
FIG. 5 is a rear elevational view thereof;
FIG. 6 is a left side elevational view thereof; and,
FIG. 7 is a right side elevational view thereof.
The dashed lines represent portions of an aircraft utilizing a the present design, and forms no part of the claimed invention.

[56] References Cited

U.S. PATENT DOCUMENTS

3,121,545 2/1964 Meleffon .
3,426,981 2/1969 Allcock .
3,871,844 3/1975 Calvin .
4,149,689 4/1979 McDonald .
4,346,860 8/1982 Tedstone .
4,354,346 10/1982 Wooding .
4,713,934 12/1987 Pellow .

1 Claim, 4 Drawing Sheets

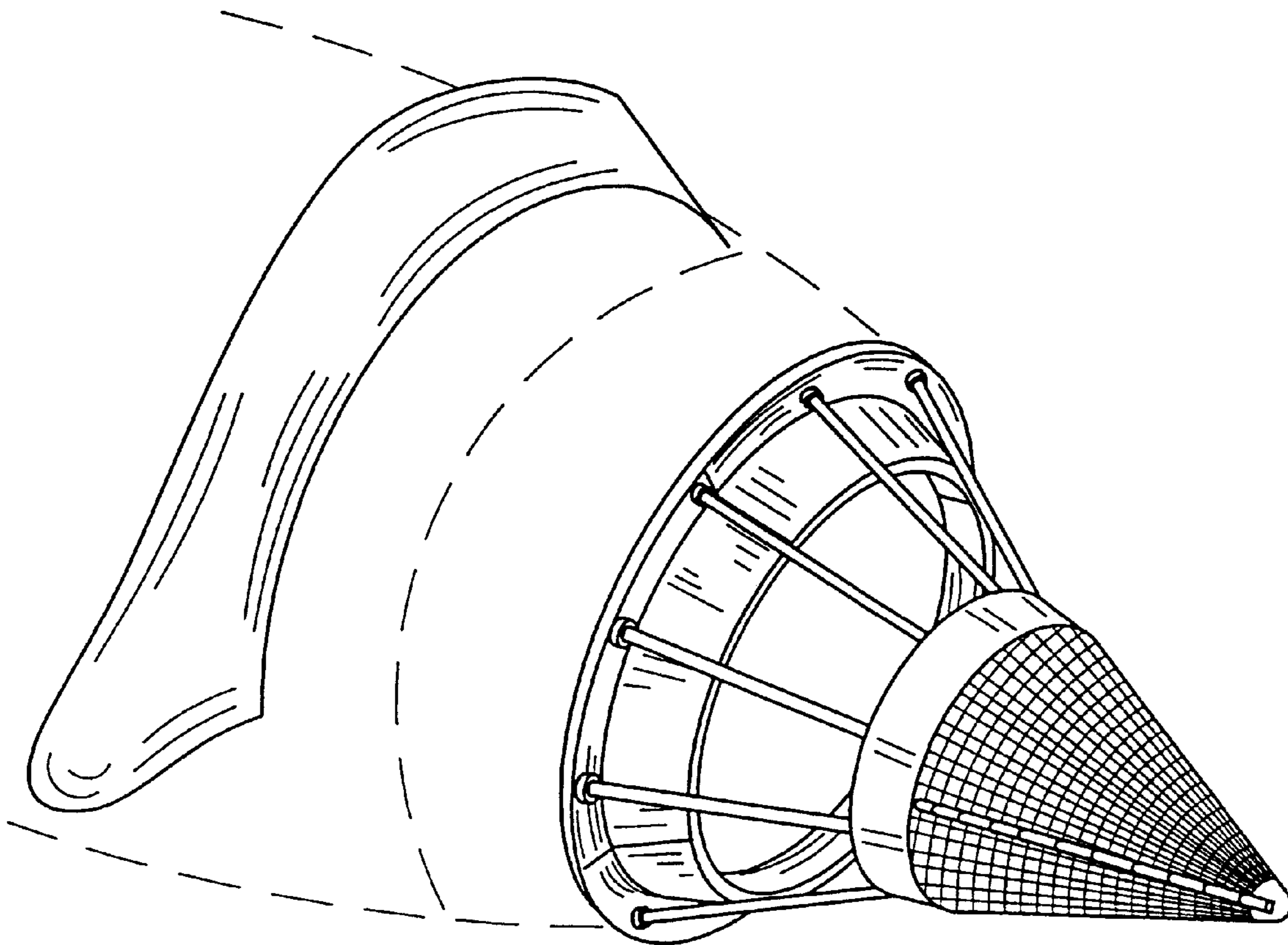

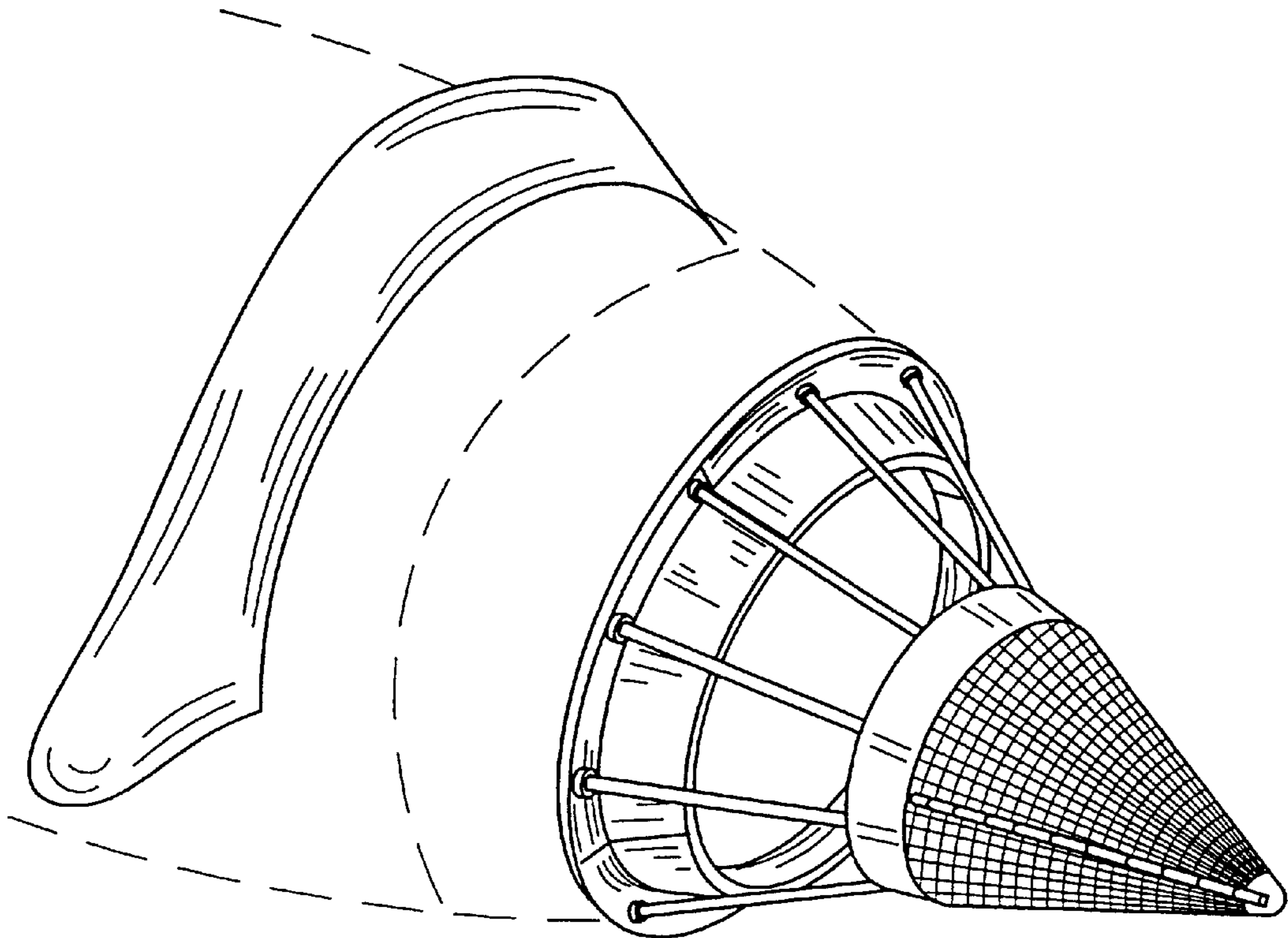

Figure 1

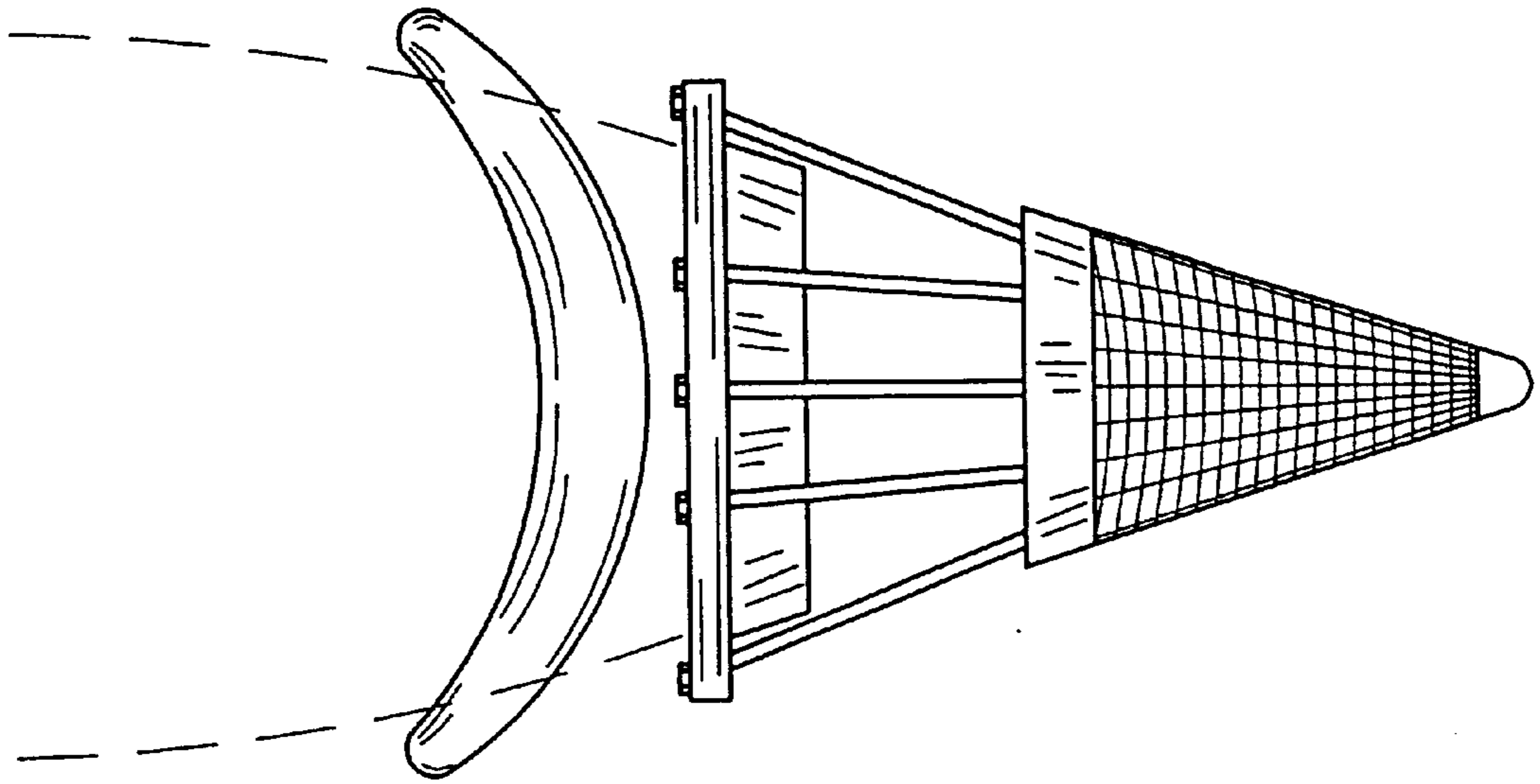

Figure 2

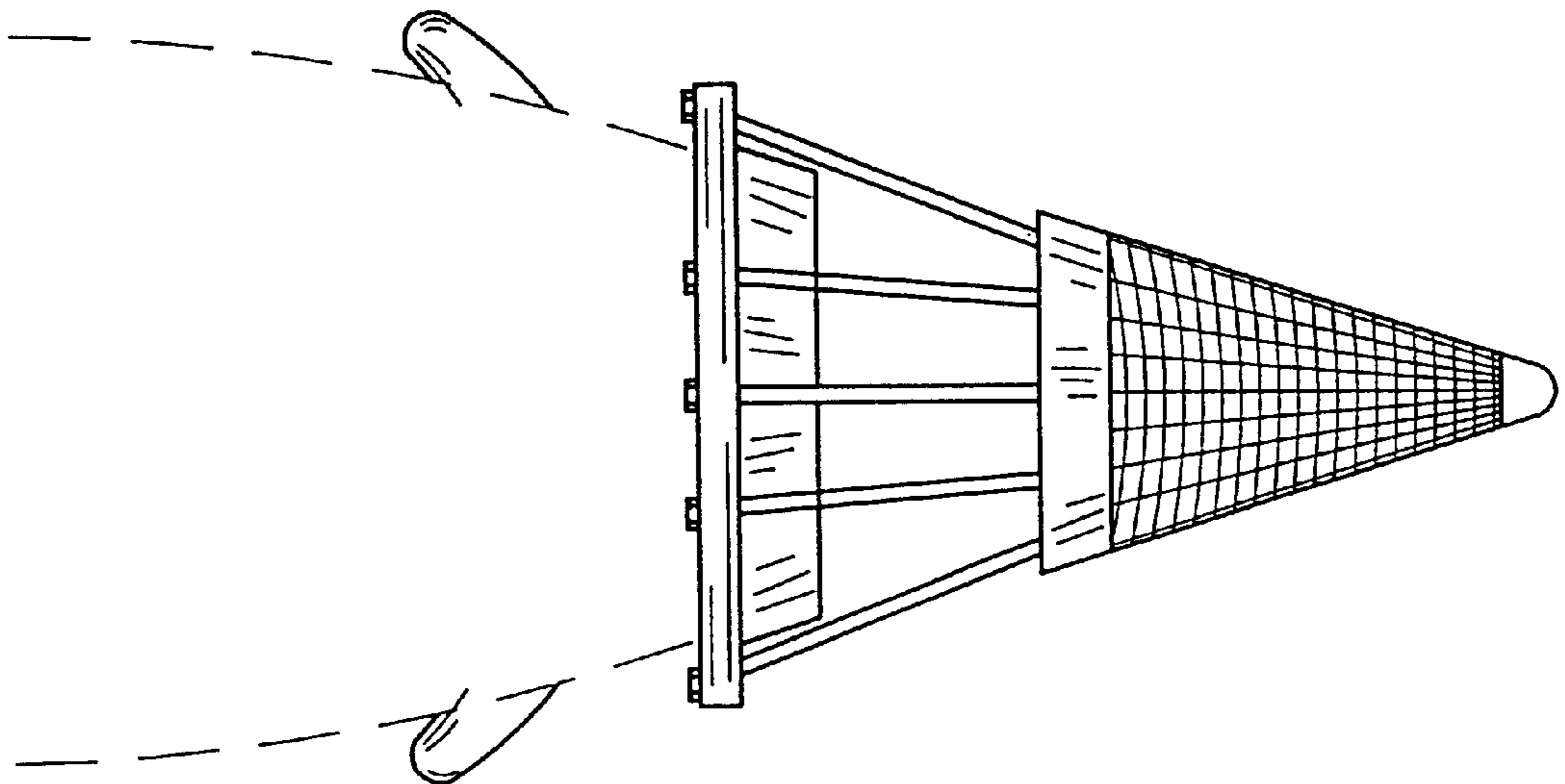

Figure 3

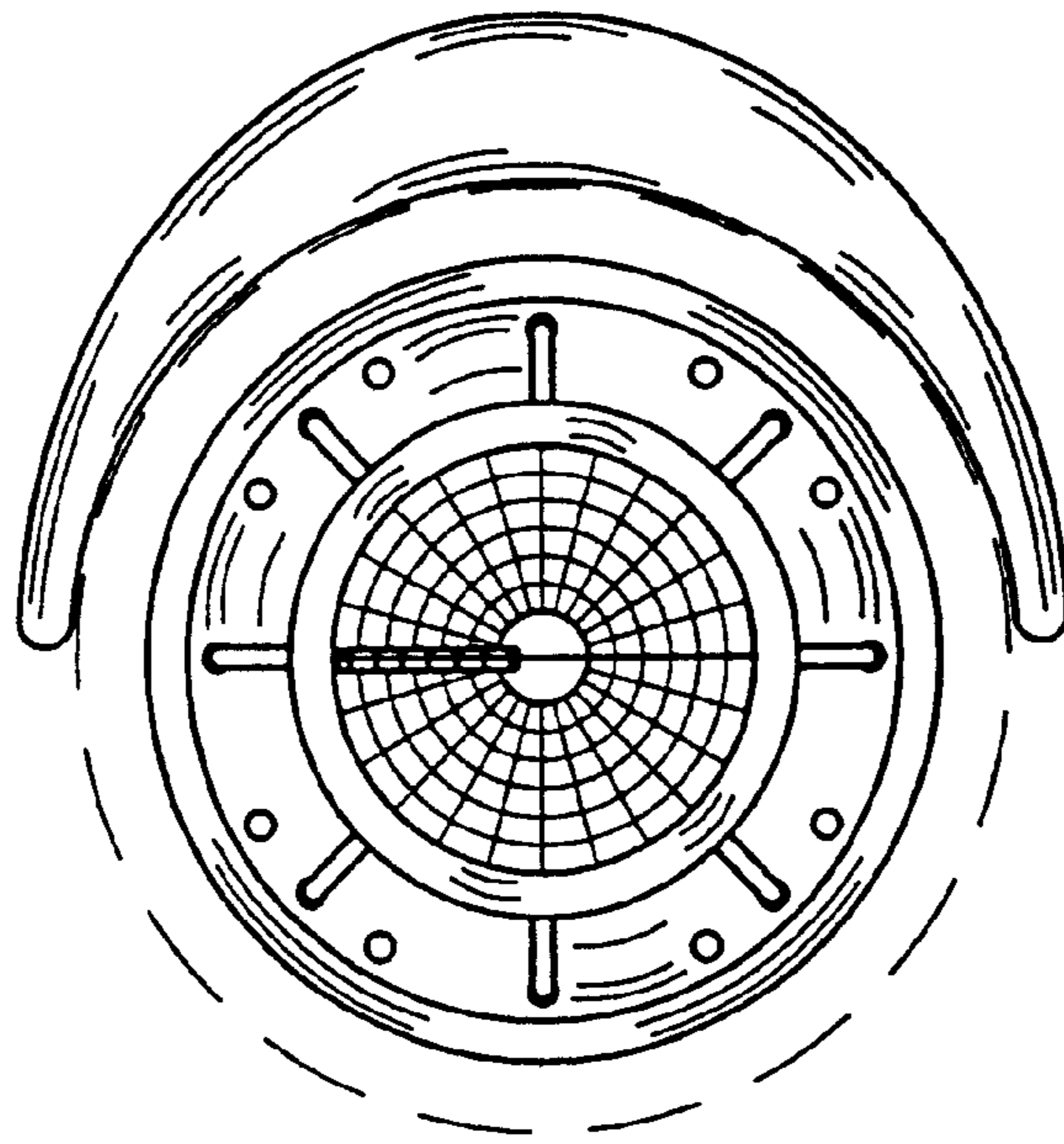

Figure 4

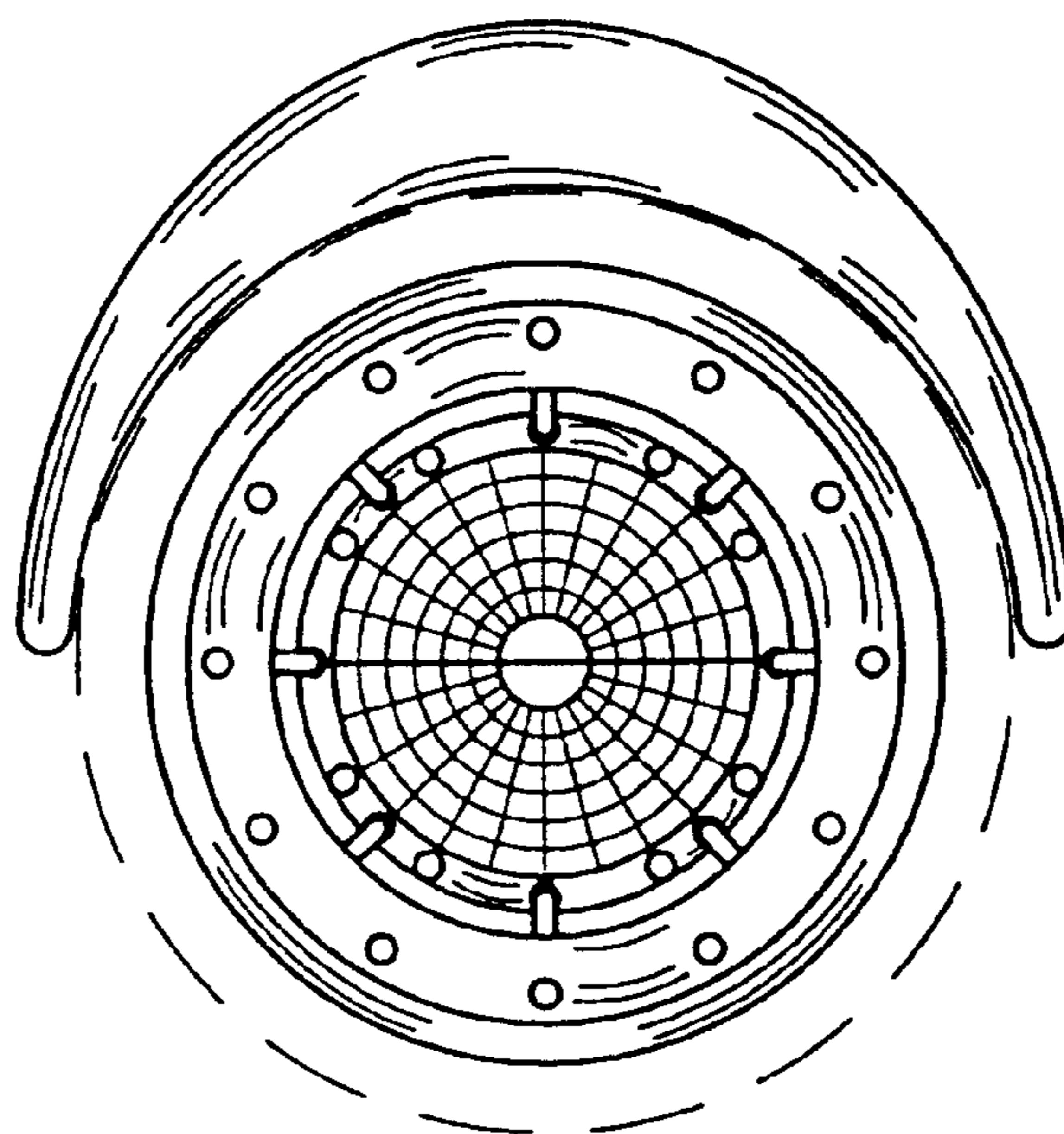

Figure 5

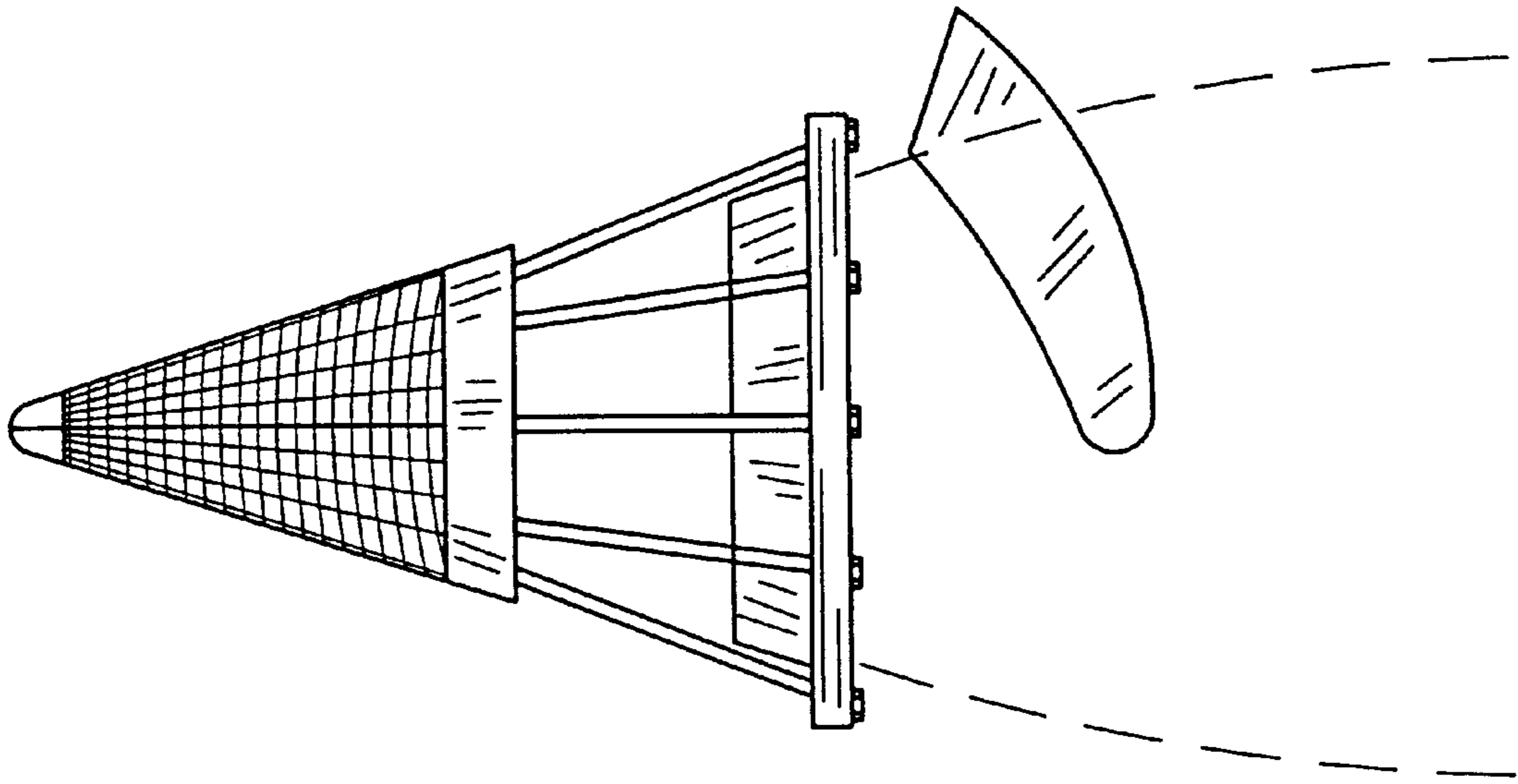

Figure 6

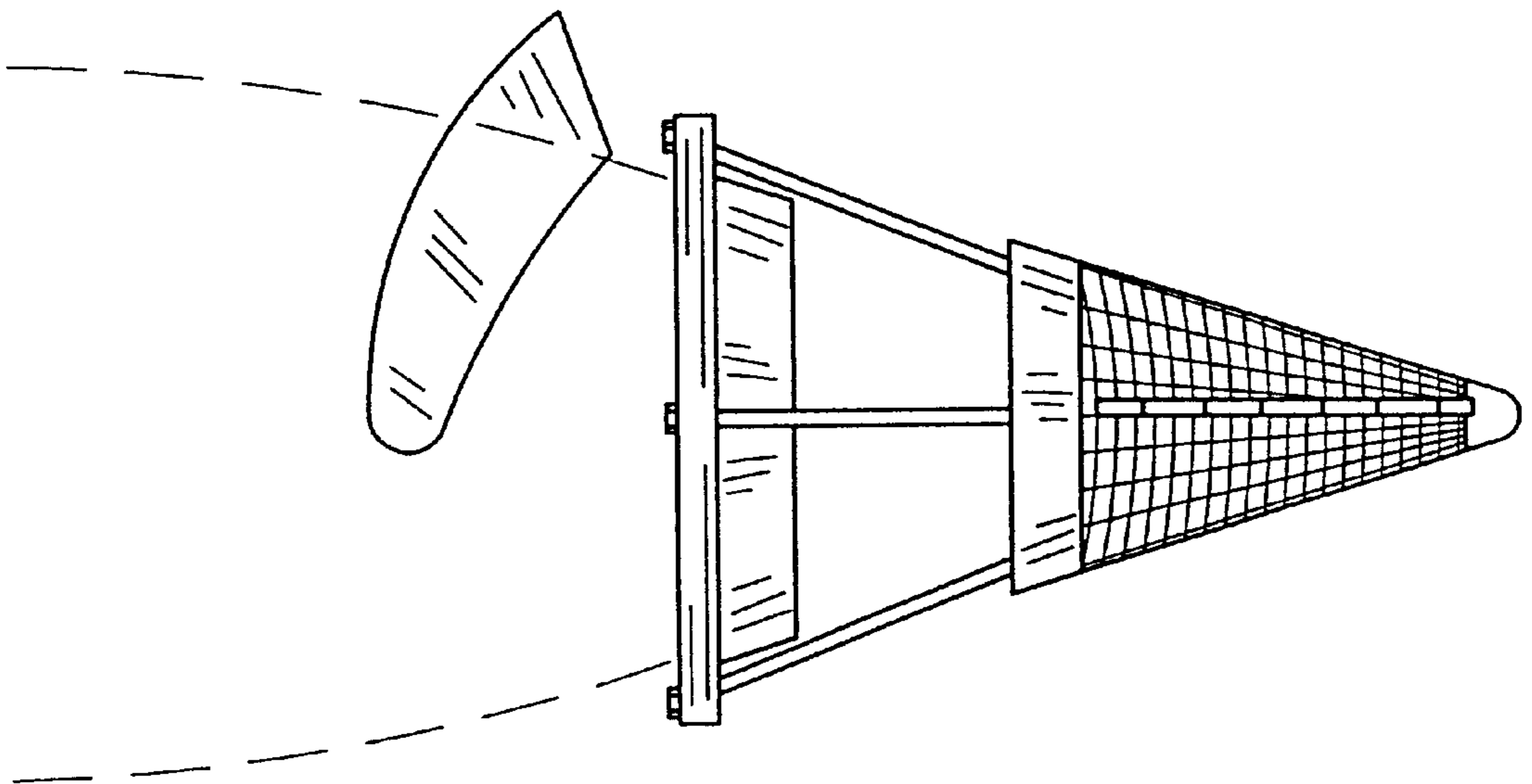

Figure 7