



US00D432983S

# United States Patent [19] Lohrding

[11] Patent Number: Des. 432,983

[45] Date of Patent: \*\* Oct. 31, 2000

[54] BATTERY CHARGER

[75] Inventor: Bradley K. Lohrding, Gurnee, Ill.

[73] Assignee: Motorola, Inc., Schaumburg, Ill.

[\*\*] Term: 14 Years

[21] Appl. No.: 29/088,221

[22] Filed: May 18, 1998

[51] LOC (7) Cl. .... 13-02

[52] U.S. Cl. .... D13/107

[58] Field of Search ..... D3/107, 108, 119;  
320/110-115

[56] References Cited

U.S. PATENT DOCUMENTS

D. 302,808	8/1989	Skuza et al. ....	D13/107
D. 328,889	8/1992	Seki .....	D13/108
D. 345,728	4/1994	Tyneski et al. ....	D13/108
D. 350,540	9/1994	Hyvönen .....	D14/149
D. 353,131	12/1994	Nagele .....	D13/107
D. 358,821	5/1995	Hellier et al. ....	D14/253
D. 361,979	9/1995	Shirakawa et al. ....	D13/108
D. 368,892	4/1996	Tanaka .....	D13/108
D. 400,164	10/1998	Lindahl .....	D13/108
D. 407,685	4/1999	Lohrding et al. ....	D13/107
D. 408,783	4/1999	Lucaci et al. ....	D13/107
D. 410,225	5/1999	Yu .....	D13/107
5,059,885	10/1991	Weiss et al. ....	320/2
5,256,954	10/1993	Chen .....	320/2

OTHER PUBLICATIONS

“MoVa”, NTT Do Co Mo., 94-4, Japan, pp. 1, 88 and 90.

Primary Examiner—Joel Sincavage

Attorney, Agent, or Firm—John G. Rauch; Lalita P. Williams

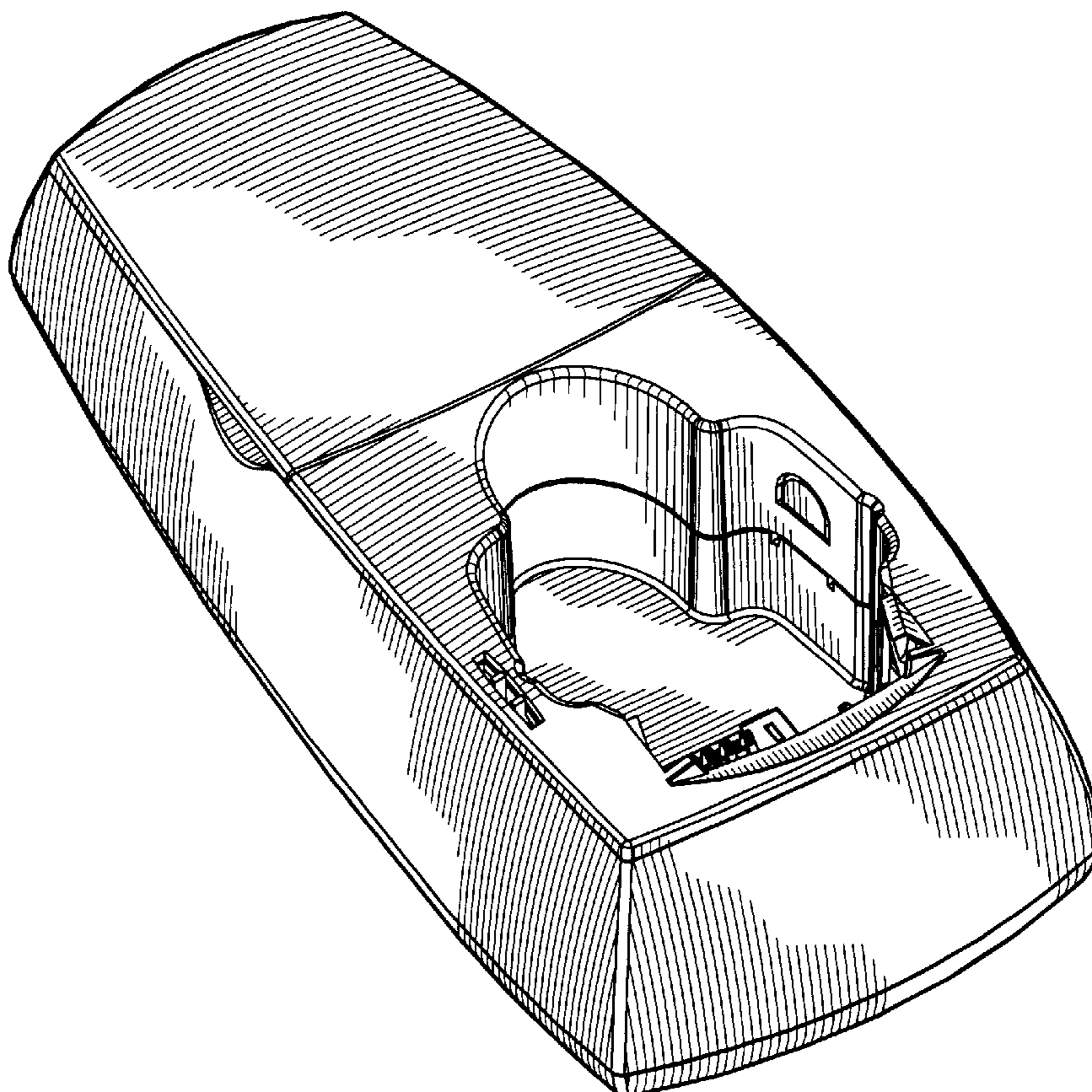
[57] CLAIM

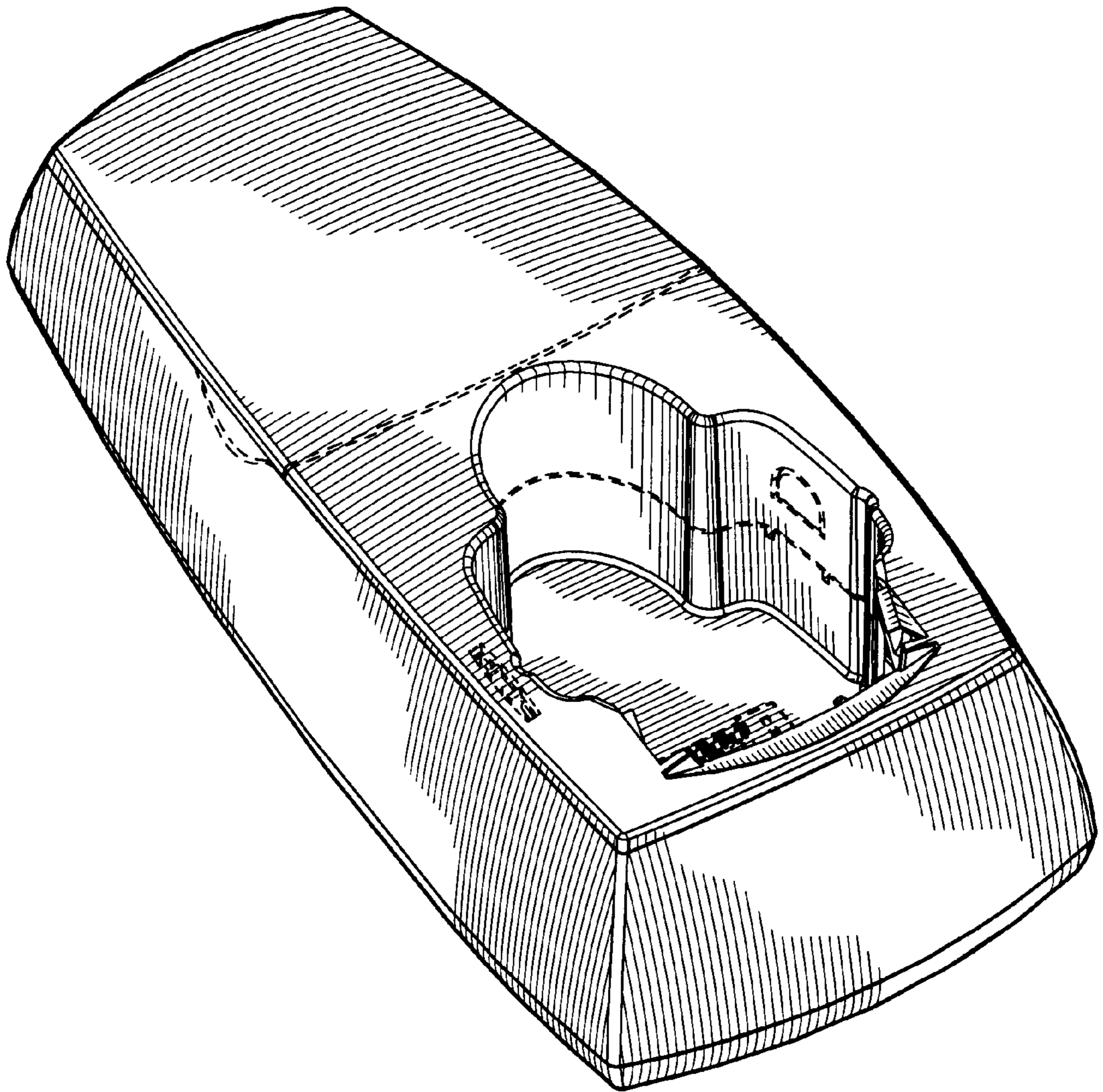
The ornamental design for a battery charger, as shown and described.

DESCRIPTION

FIG. 1 is a right, front, top view of a first embodiment of a battery charger, showing our new design; FIG. 2 is a front elevation view thereof; FIG. 3 is a top elevation view thereof; FIG. 4 is a left side elevation view thereof; FIG. 5 is a right side elevation view thereof; FIG. 6 is a bottom elevation view thereof; and FIG. 7 is a rear elevation view thereof; FIG. 8 is a right, front, top view of a second embodiment of a battery charger, showing our new design; FIG. 9 is a front elevation view thereof; FIG. 10 is a top elevation view thereof; FIG. 11 is a left side elevation view thereof; FIG. 12 is a right side elevation view thereof; FIG. 13 is a bottom elevation view thereof; and, FIG. 14 is a right side elevation view thereof. The broken lines shown in FIGS. 1-7 are for illustrative purposes only and form no part of the claimed design.

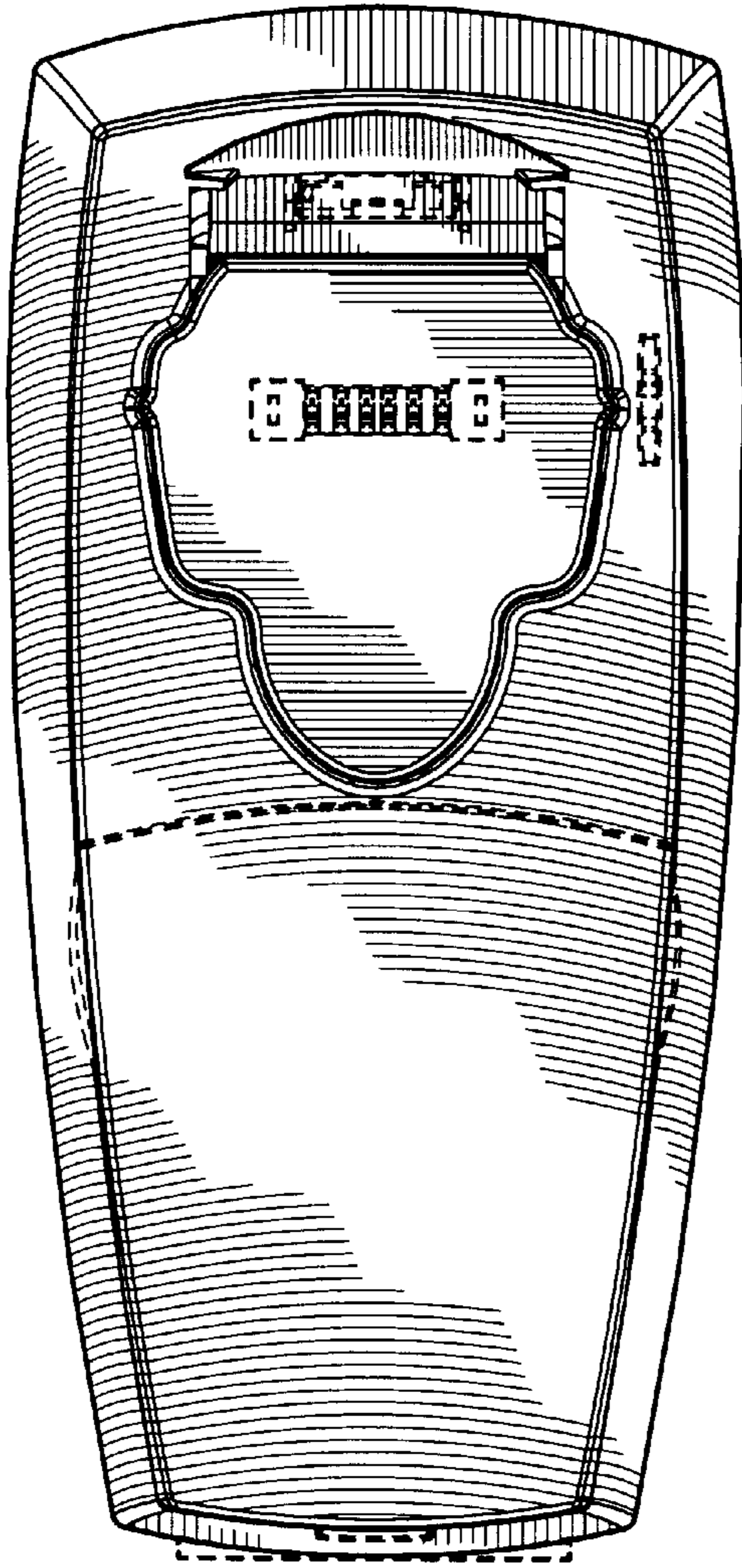
1 Claim, 6 Drawing Sheets



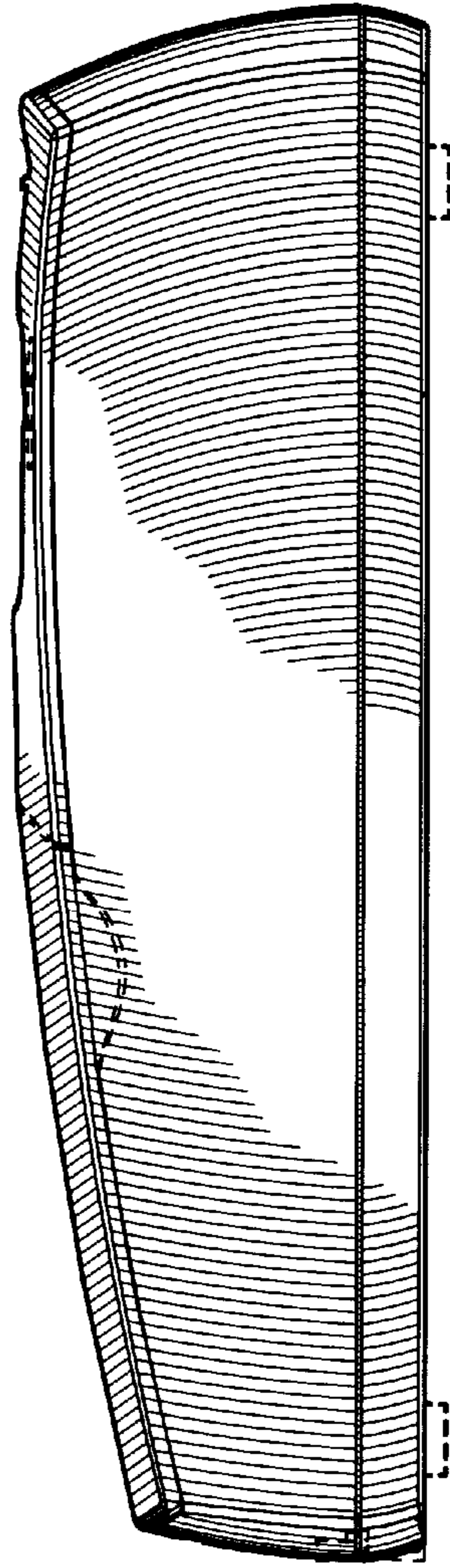


*FIG. 1*

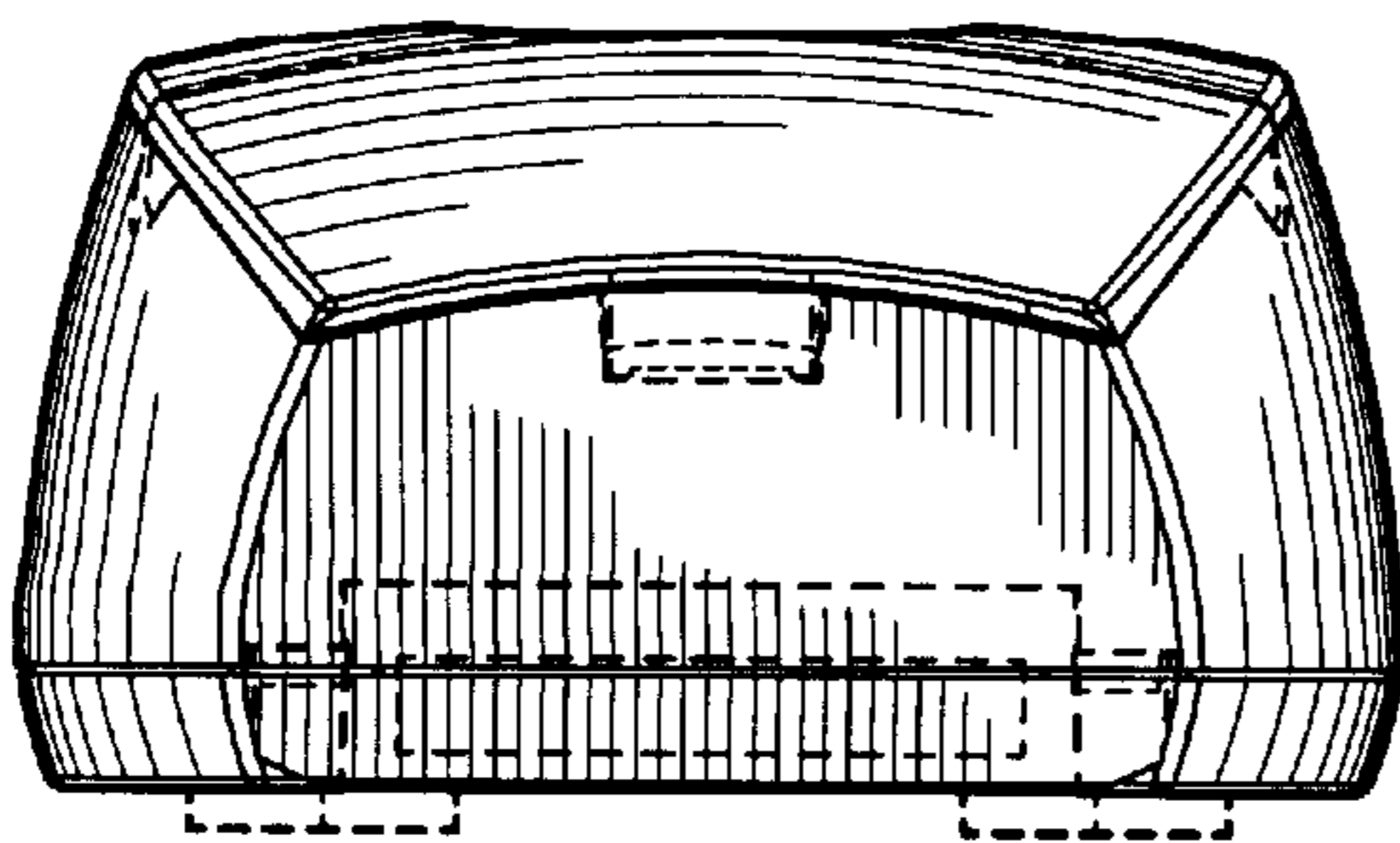




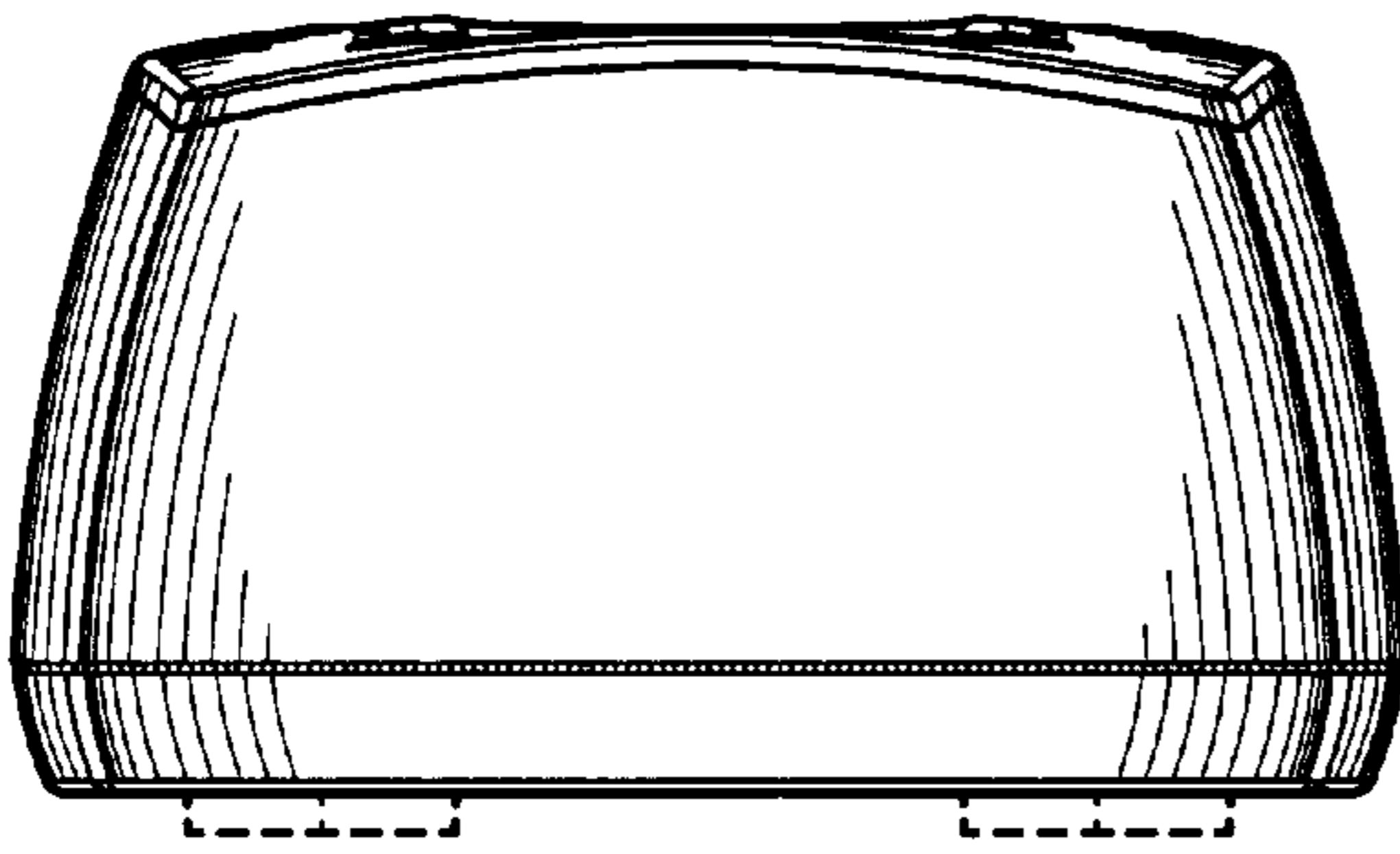
*FIG. 2*



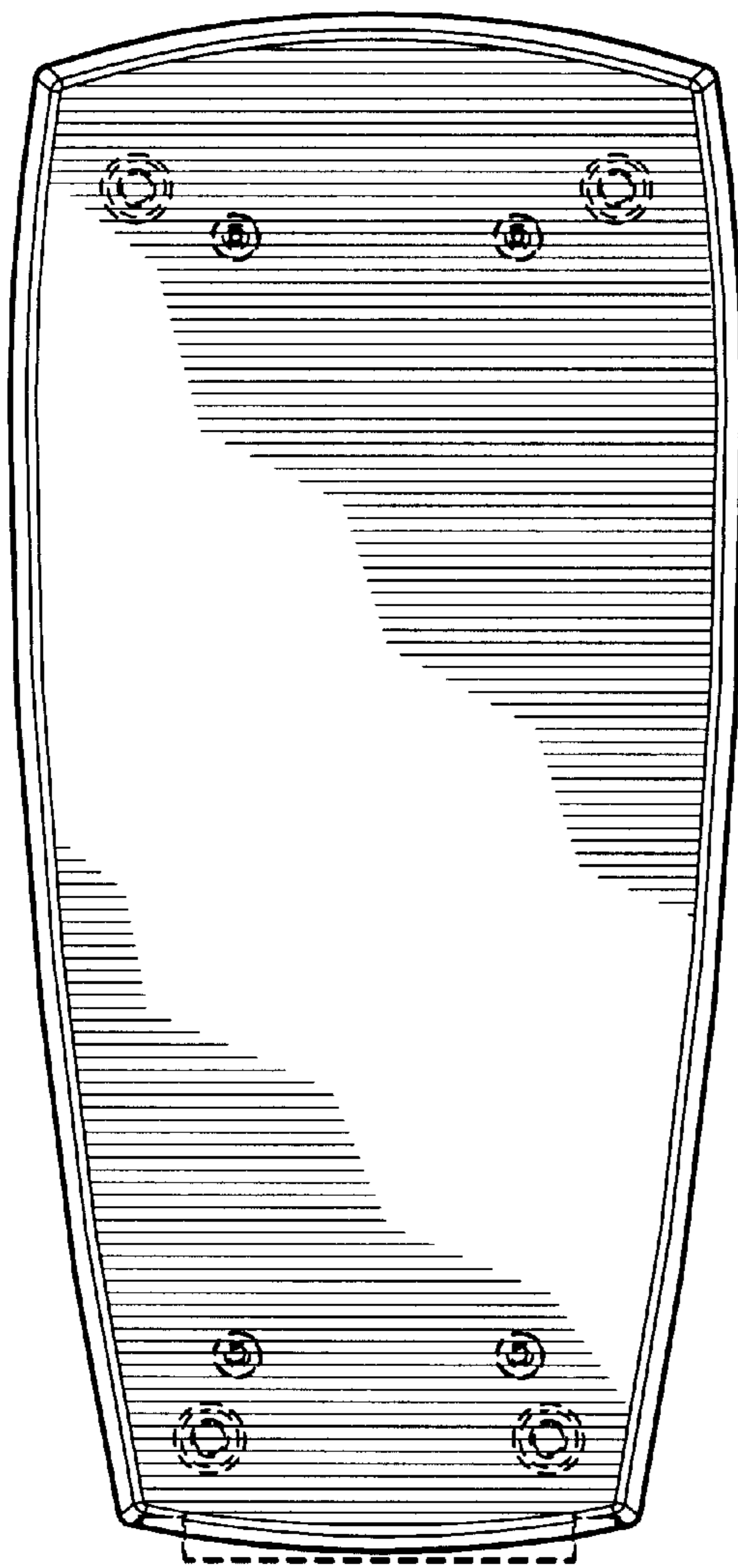
*FIG. 3*



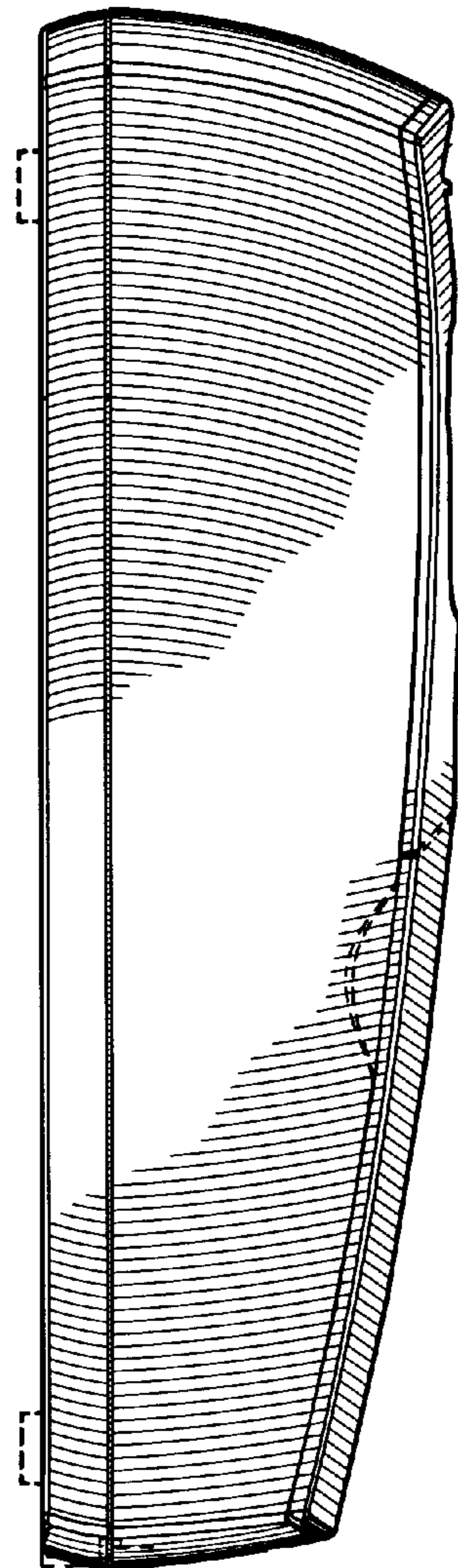
*FIG. 4*



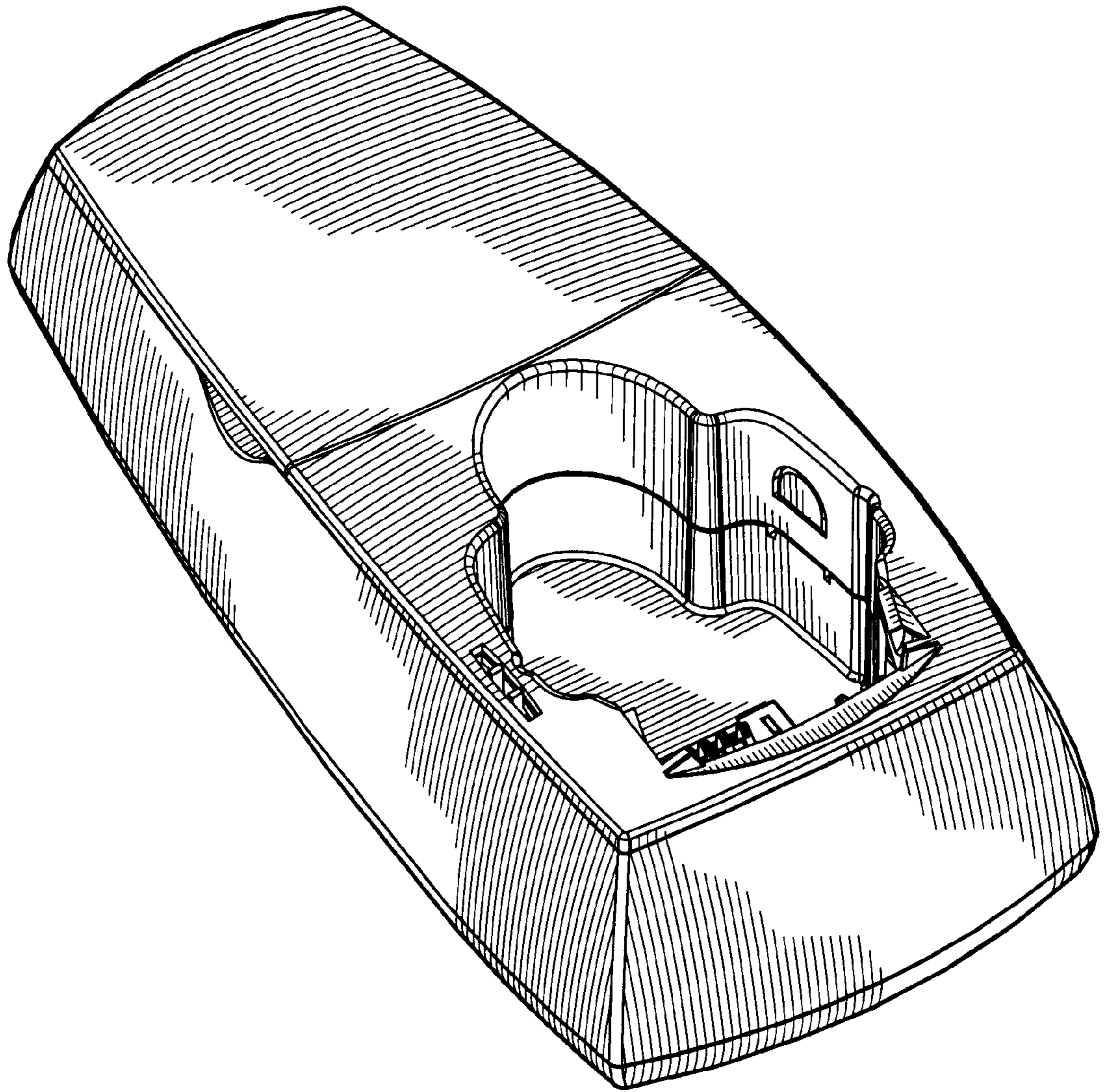
*FIG. 5*



*FIG. 6*

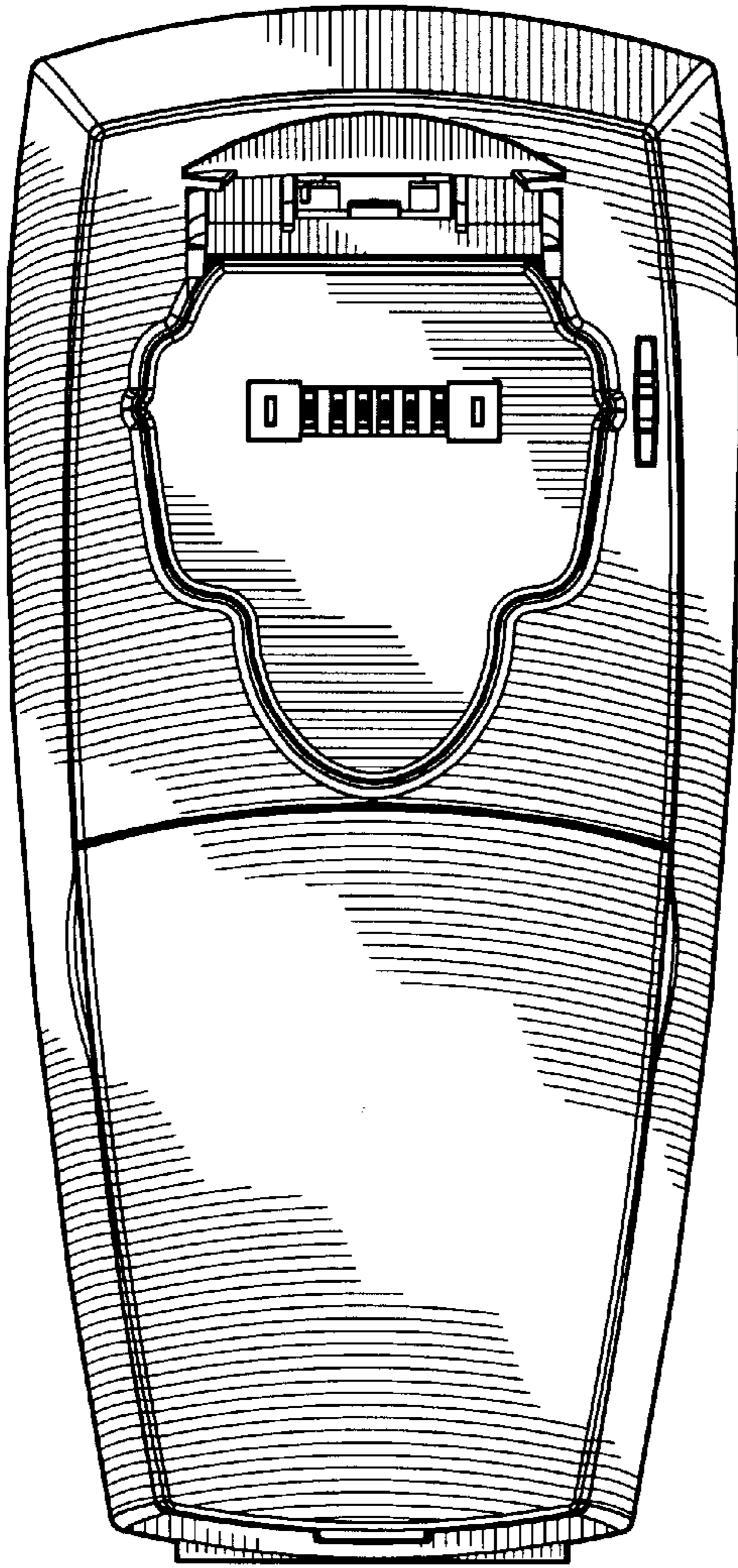


*FIG. 7*

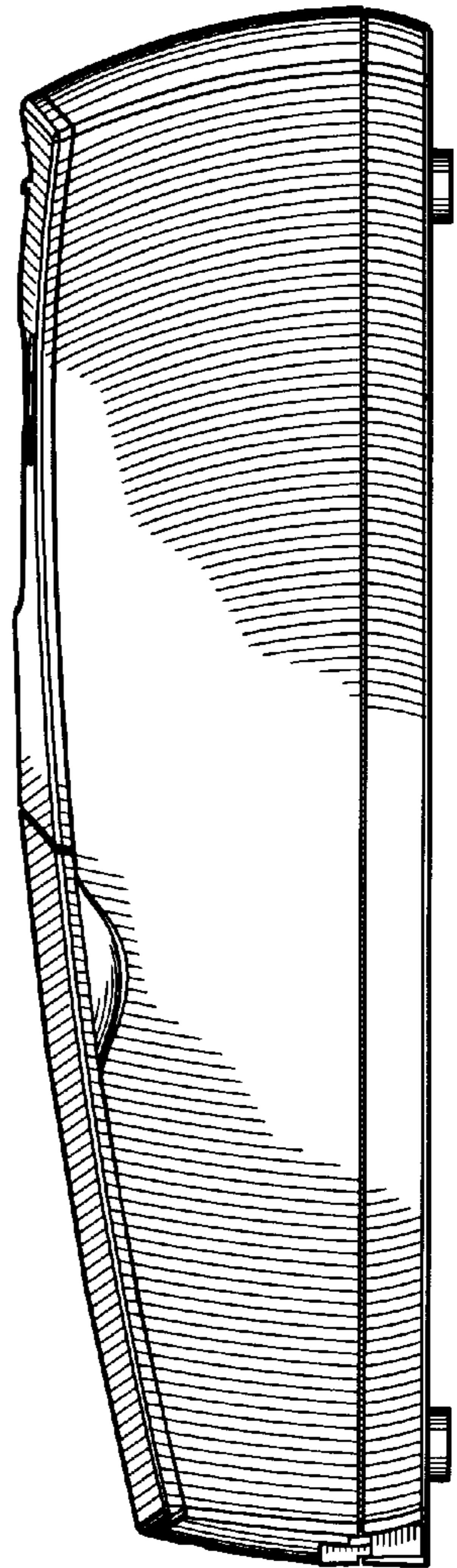


*FIG. 8*

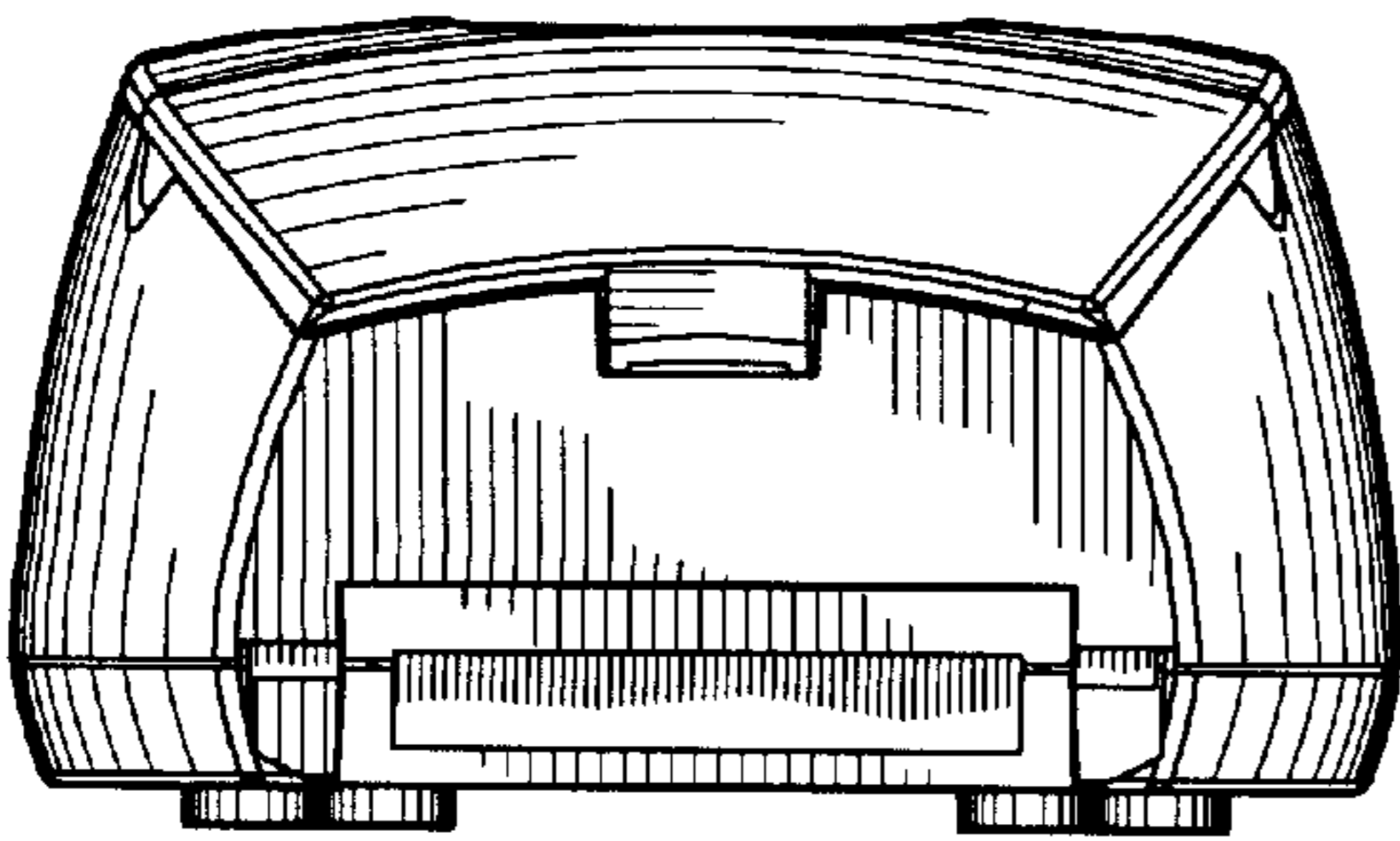




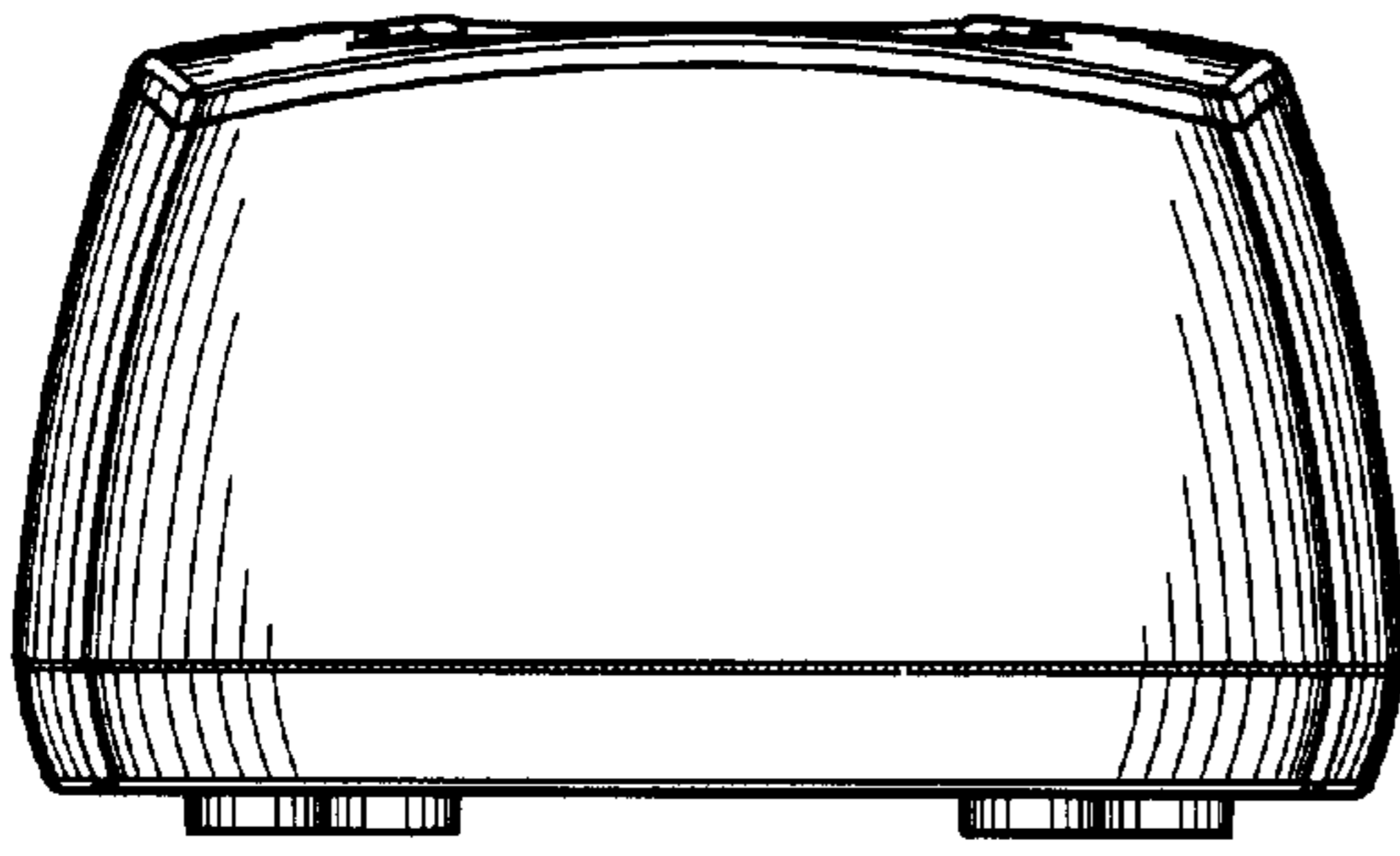
*FIG. 9*



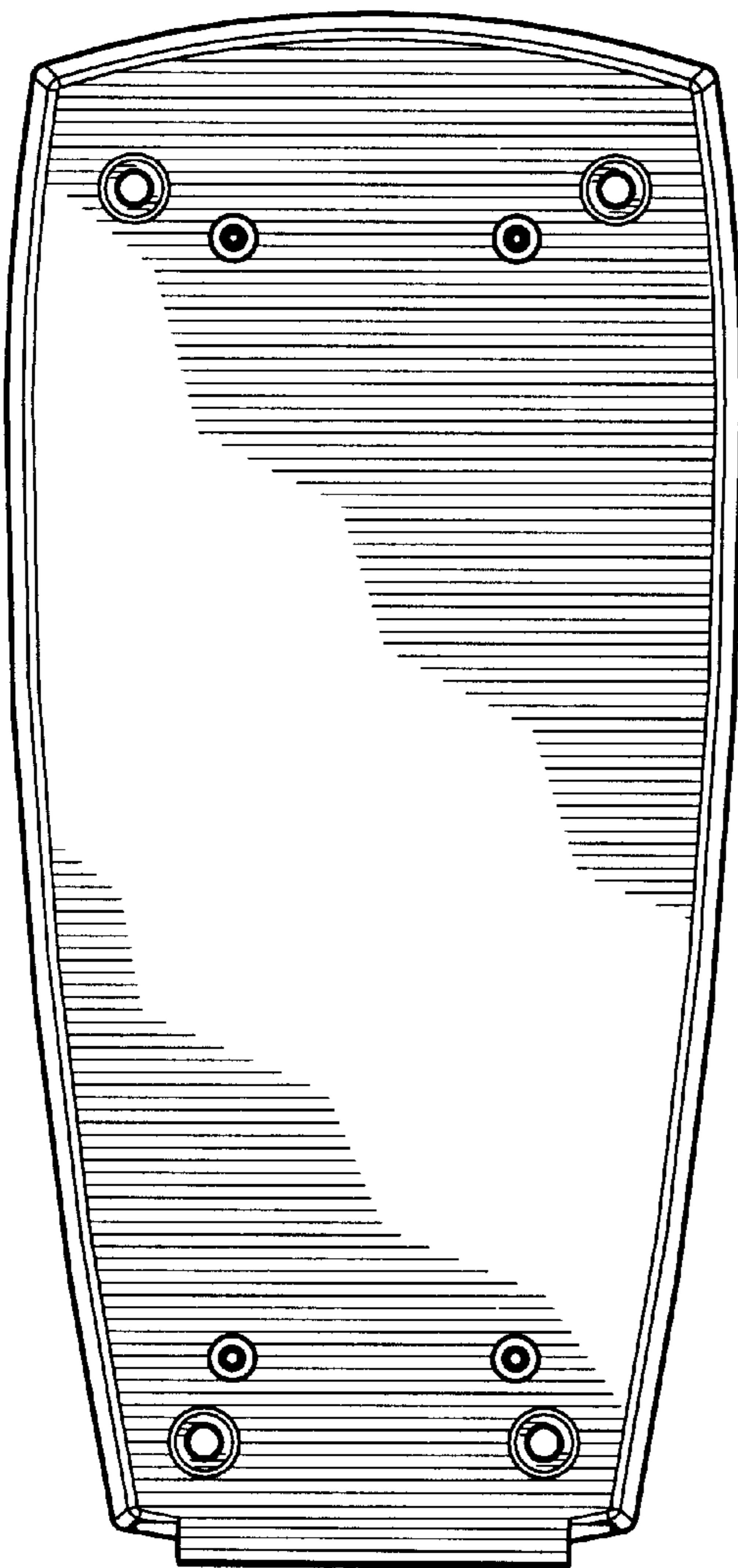
*FIG. 10*



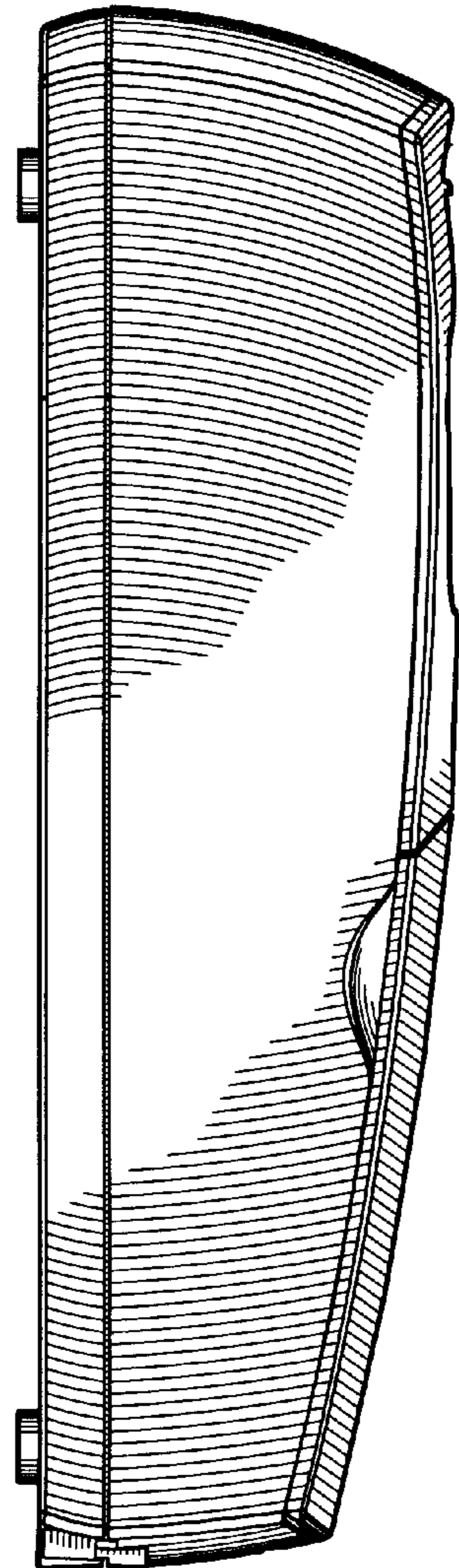
*FIG. 11*



*FIG. 12*



*FIG. 13*



*FIG. 14*