



US00D432468S

United States Patent [19]

Hoyle, Jr.

[11] **Patent Number: Des. 432,468**

[45] **Date of Patent: ** Oct. 24, 2000**

[54] **TAIL-LIGHT APERTURES INCORPORATED WITHIN A VEHICLE BUMPER**

Attorney, Agent, or Firm—Gifford, Krass, Groh, Sprinkle, Anderson & Citkowski, P.C.

[75] Inventor: **Frederick L. Hoyle, Jr.**, Pickerington, Ohio

[57] CLAIM

[73] Assignee: **Reflexion Automotive Products LLC**, Memphis, Tenn.

I claim the ornamental design for a tail-light apertures incorporated within a vehicle bumper, as shown and described.

[**] Term: **14 Years**

DESCRIPTION

[21] Appl. No.: **29/082,024**

[22] Filed: **Jan. 12, 1998**

[51] **LOC (7) Cl.** **12-16**

[52] **U.S. Cl.** **D12/167**

[58] **Field of Search** D12/167, 90-92,
D12/98; 296/185

FIG. 1 is a perspective view of tail-light apertures incorporated within a vehicle bumper showing my new design, the bumper shown in broken lines are for illustrative purposes only and form no part of the claimed design;

FIG. 2 is an enlarged fragmentary front elevational view of one of the tail-light apertures;

FIG. 3 is an enlarged fragmentary rear elevational view of the tail-light aperture in FIG. 2;

FIG. 4 is an enlarged fragmentary vertical cross sectional view of the tail-light aperture in FIG. 2 taken along line 4—4 in FIG. 2; and,

FIG. 5 is an enlarged horizontal cross sectional view of the tail-light aperture in FIG. 2 taken along line 5—5 in FIG. 2.

[56] References Cited

U.S. PATENT DOCUMENTS

- D. 186,160 9/1959 Schemansky .
- D. 187,368 3/1960 MacKichan .
- 5,482,336 1/1996 Rouse et al. .

OTHER PUBLICATIONS

JC Whitney The Catalog No. 580-2C, the rear roll pan & ZR1-Style Lights for Pickup, p. 120, ©1995.

Primary Examiner—Melody N. Brown

1 Claim, 2 Drawing Sheets

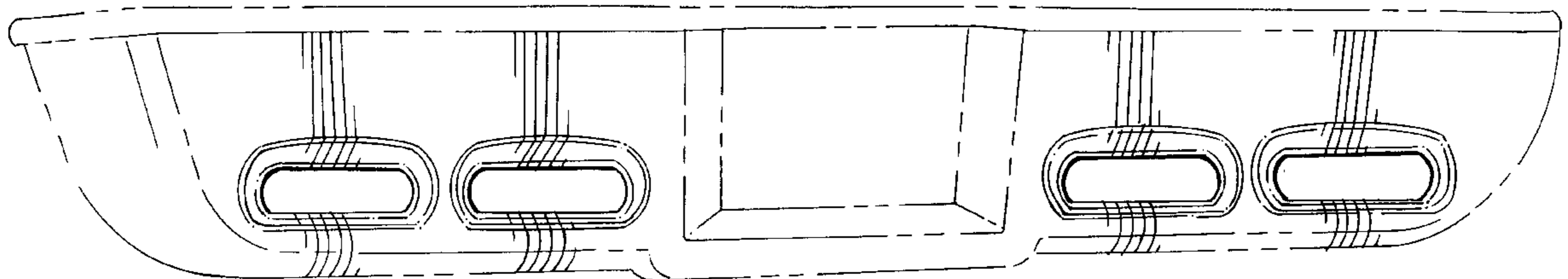

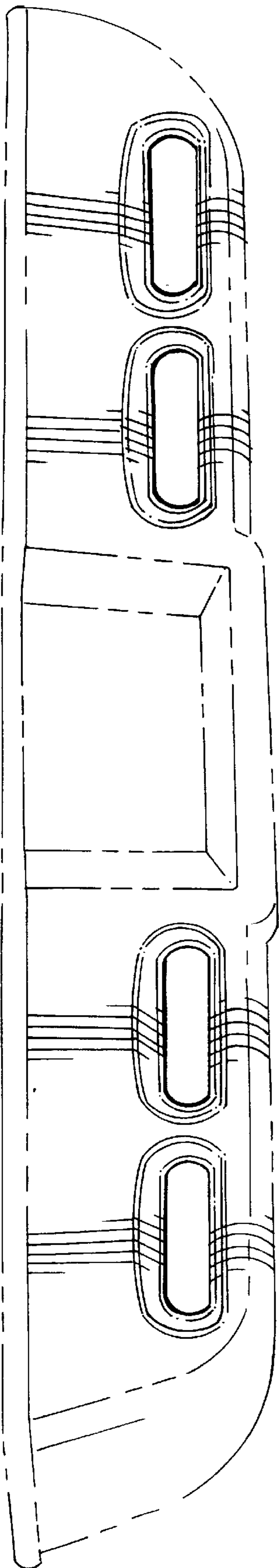

Fig-1

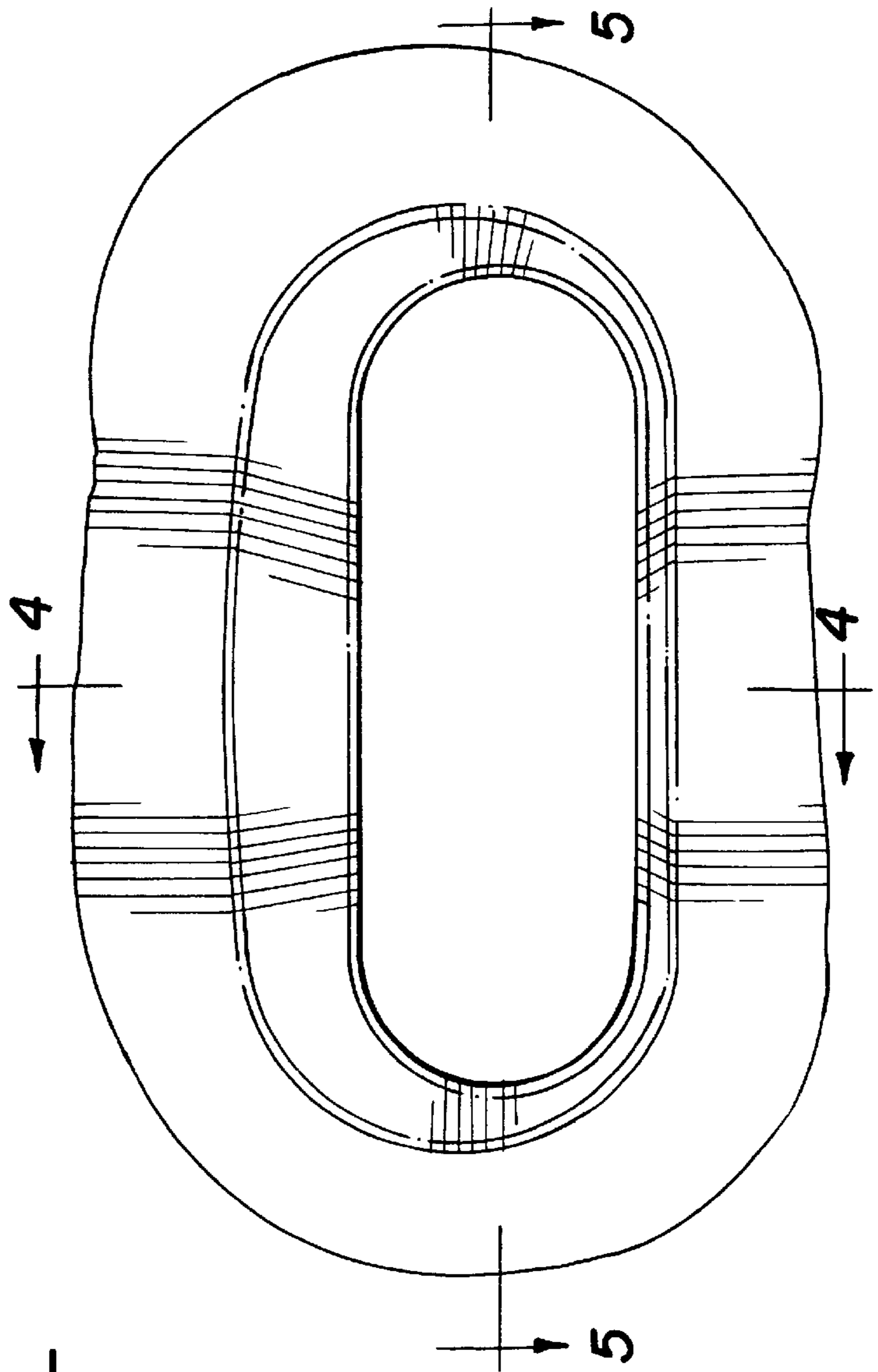

Fig-2

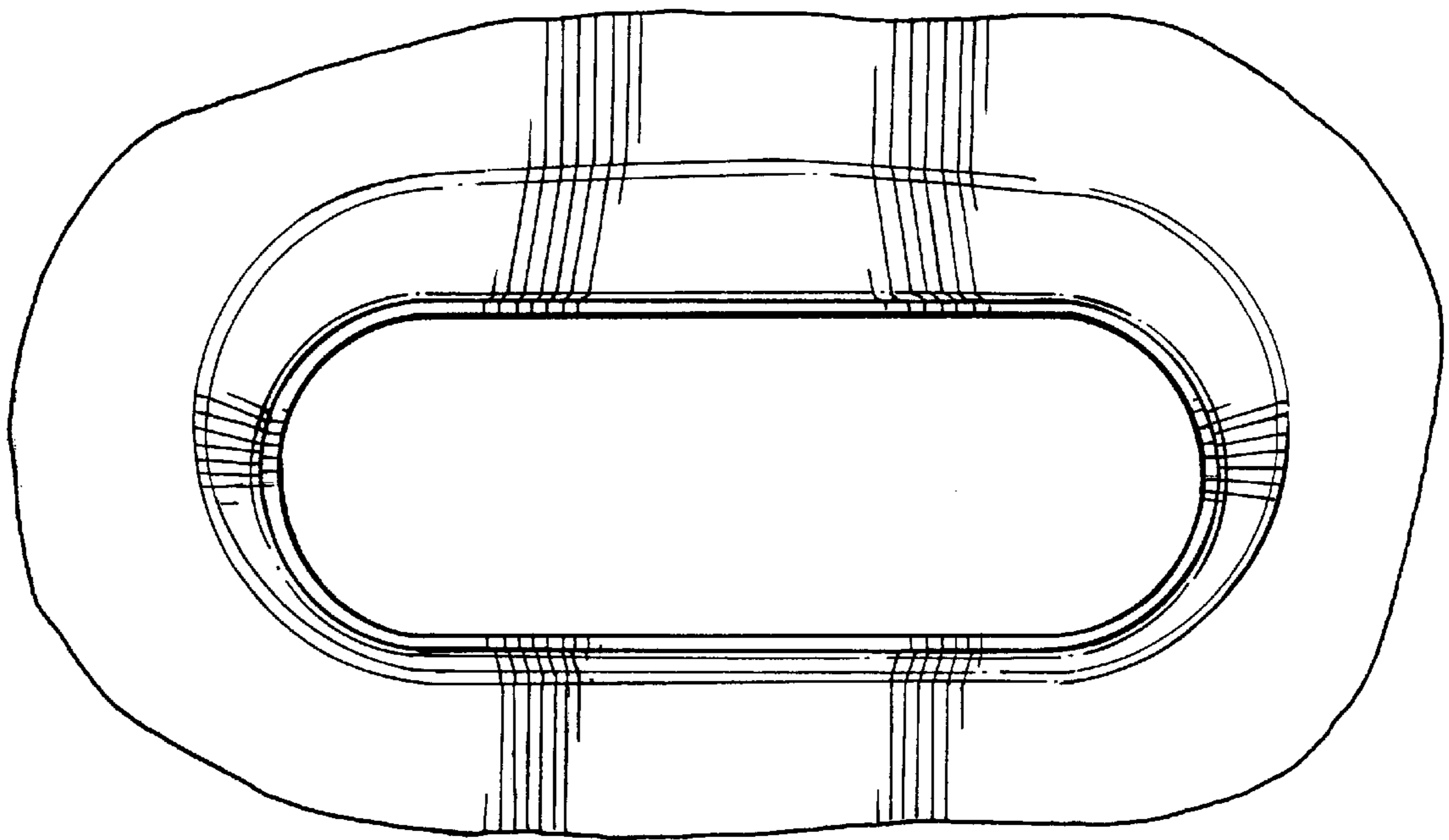

Fig-3

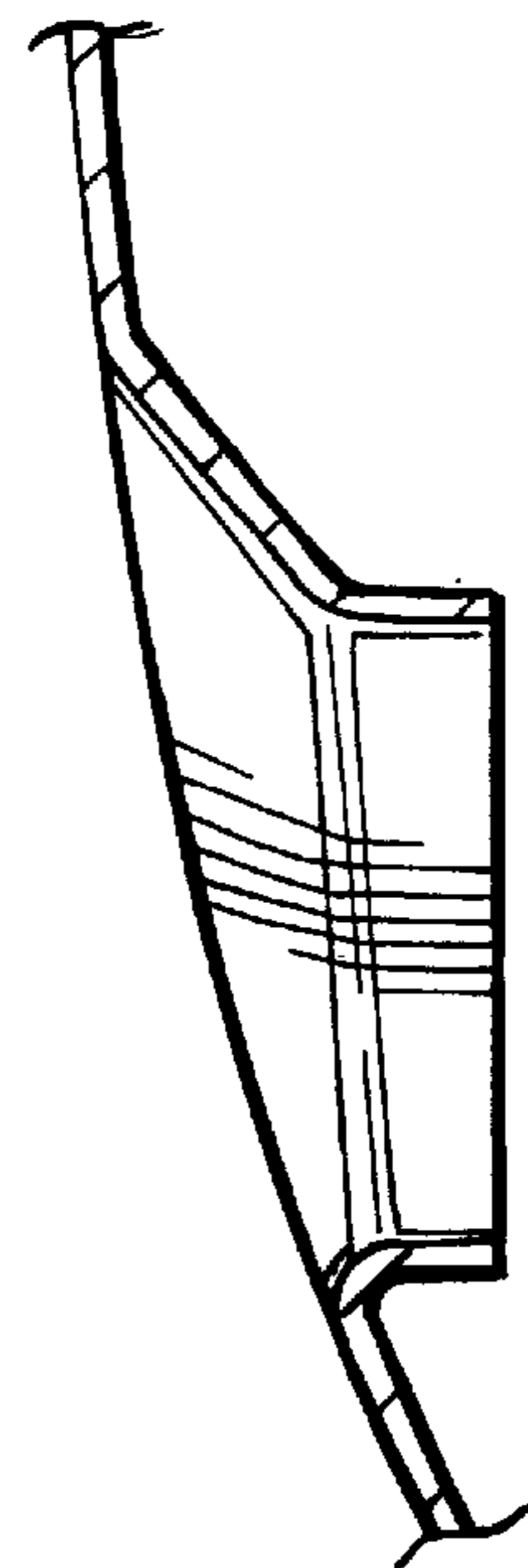

Fig-4

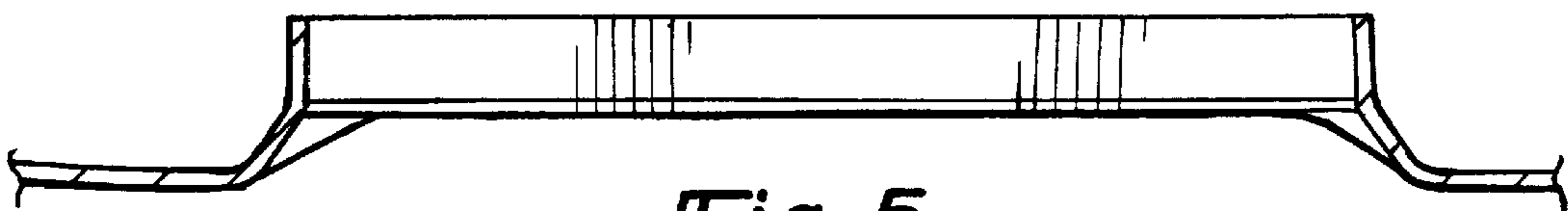

Fig-5