



US00D432461S

United States Patent [19]
Schwalbe

[11] **Patent Number: Des. 432,461**

[45] **Date of Patent: ** Oct. 24, 2000**

[54] **TRUCK CAB**

[76] Inventor: **Dennis A. Schwalbe**, P.O. Box 366,
Muenster, Tex. 76252

[**] Term: **14 Years**

[21] Appl. No.: **29/109,884**

[22] Filed: **Aug. 25, 1999**

[51] **LOC (7) Cl.** **12-08**

[52] **U.S. Cl.** **D12/96**

[58] **Field of Search** D12/96, 97, 99;
296/180.1-180.3, 190, 37.7; 180/90, 89.12,
89.13

[56] **References Cited**

U.S. PATENT DOCUMENTS

- D. 336,875 6/1993 Cox .
- D. 376,772 12/1996 Martin D12/96
- D. 384,914 10/1997 Bingaman .
- D. 385,223 10/1997 Marlowe et al. .
- D. 391,524 3/1998 Anderson et al. .
- D. 406,553 3/1999 Hellkuhe D12/96
- D. 408,331 4/1999 Sacco et al. .
- D. 411,140 6/1999 Meryman et al. .
- D. 411,816 7/1999 Reynard et al. D12/96

- D. 412,463 8/1999 Sacco et al. D12/96
- D. 483,620 1/1999 Abalos et al. D12/96
- 5,769,486 6/1998 Novoa et al. .

Primary Examiner—Melody N. Brown
Attorney, Agent, or Firm—Felsman, Bradley, Vaden, Gunter
& Dillon, L.L.P.; James E. Bradley

[57] **CLAIM**

The ornamental design for a truck cab, as shown and described.

DESCRIPTION

FIG. 1 is a front view of a truck cab constructed in accordance with our design.
 FIG. 2 is a rear side view of a truck cab constructed in accordance with our design.
 FIG. 3 is a right side view of a truck cab constructed in accordance with our design.
 FIG. 4 is a left side view of a truck cab constructed in accordance with our design; and,
 FIG. 5 is a top view of a truck cab constructed in accordance with our design.
 Features shown in broken lines depict the environment and do not form part of the claimed design. The bottom of the truck cab is not claimed.

1 Claim, 4 Drawing Sheets

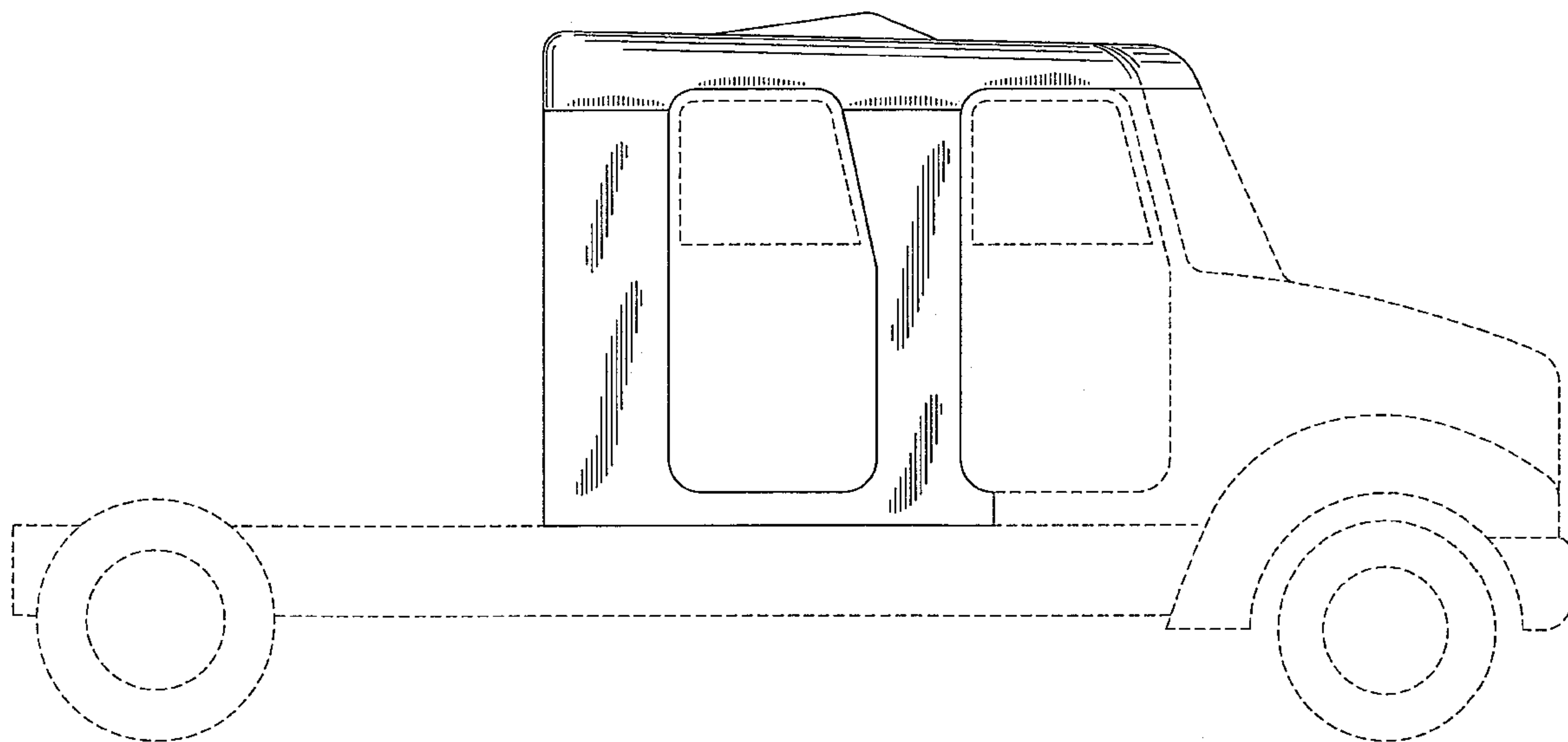

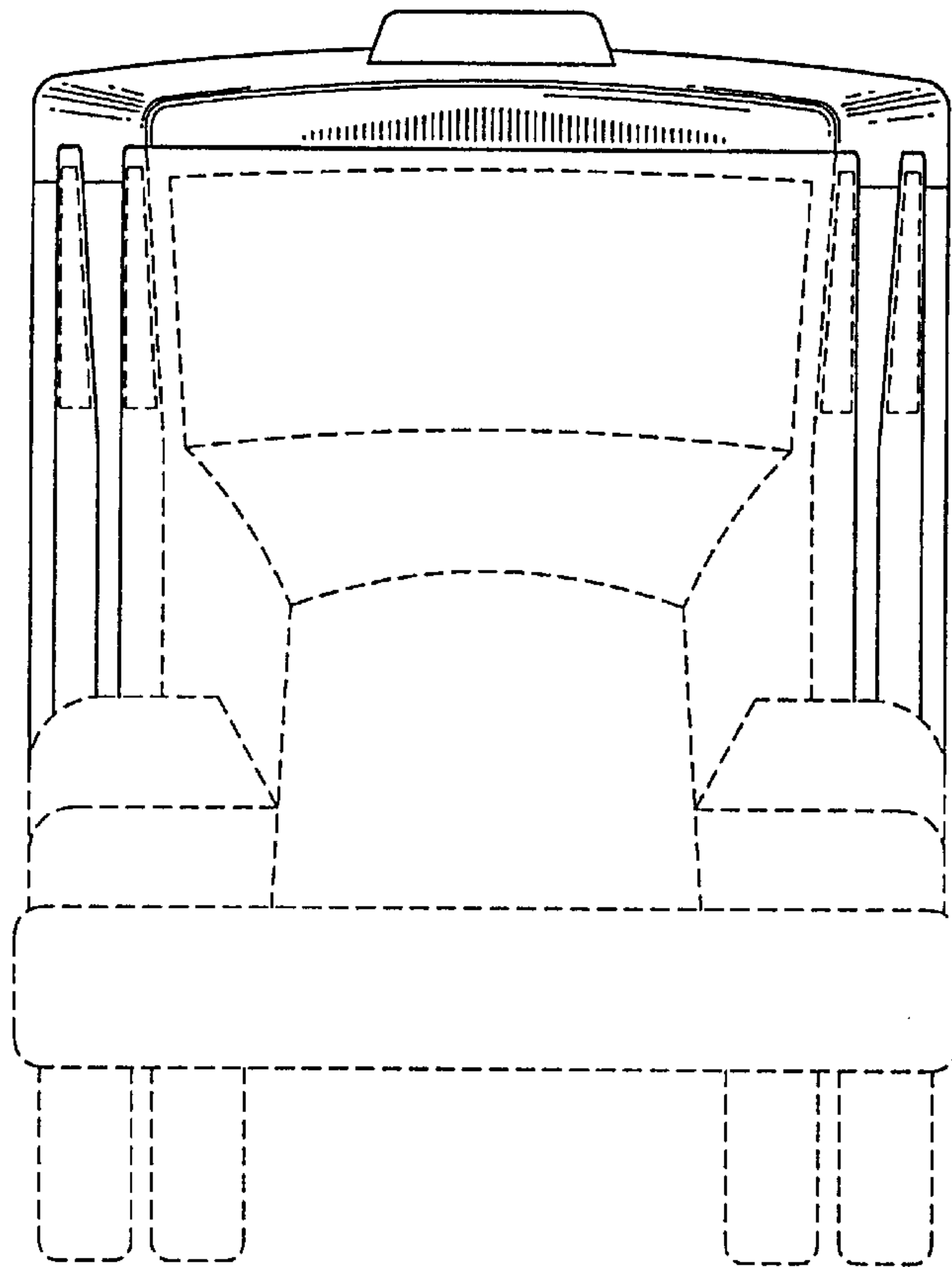

Fig. 1

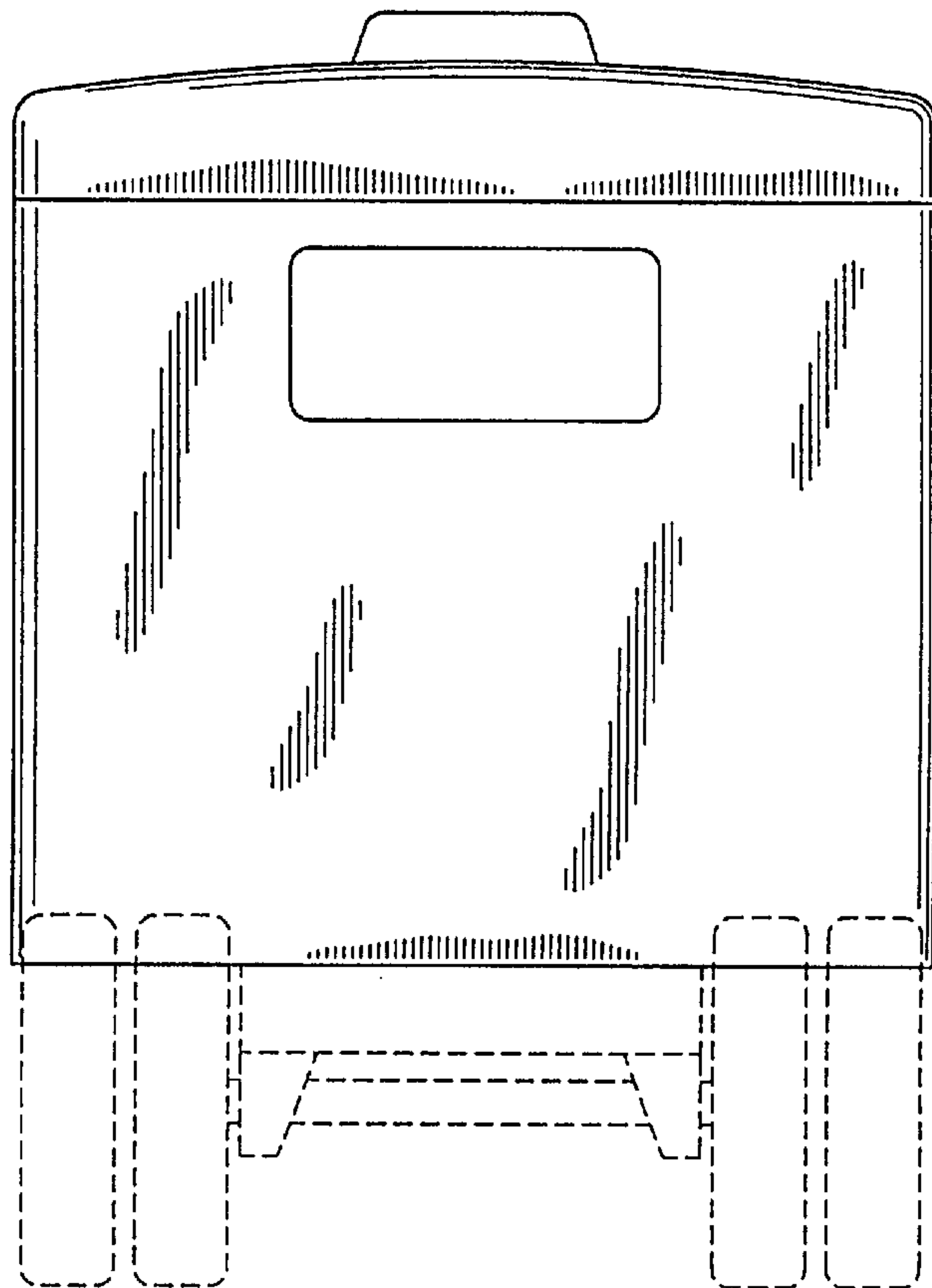

Fig. 2

Fig. 3

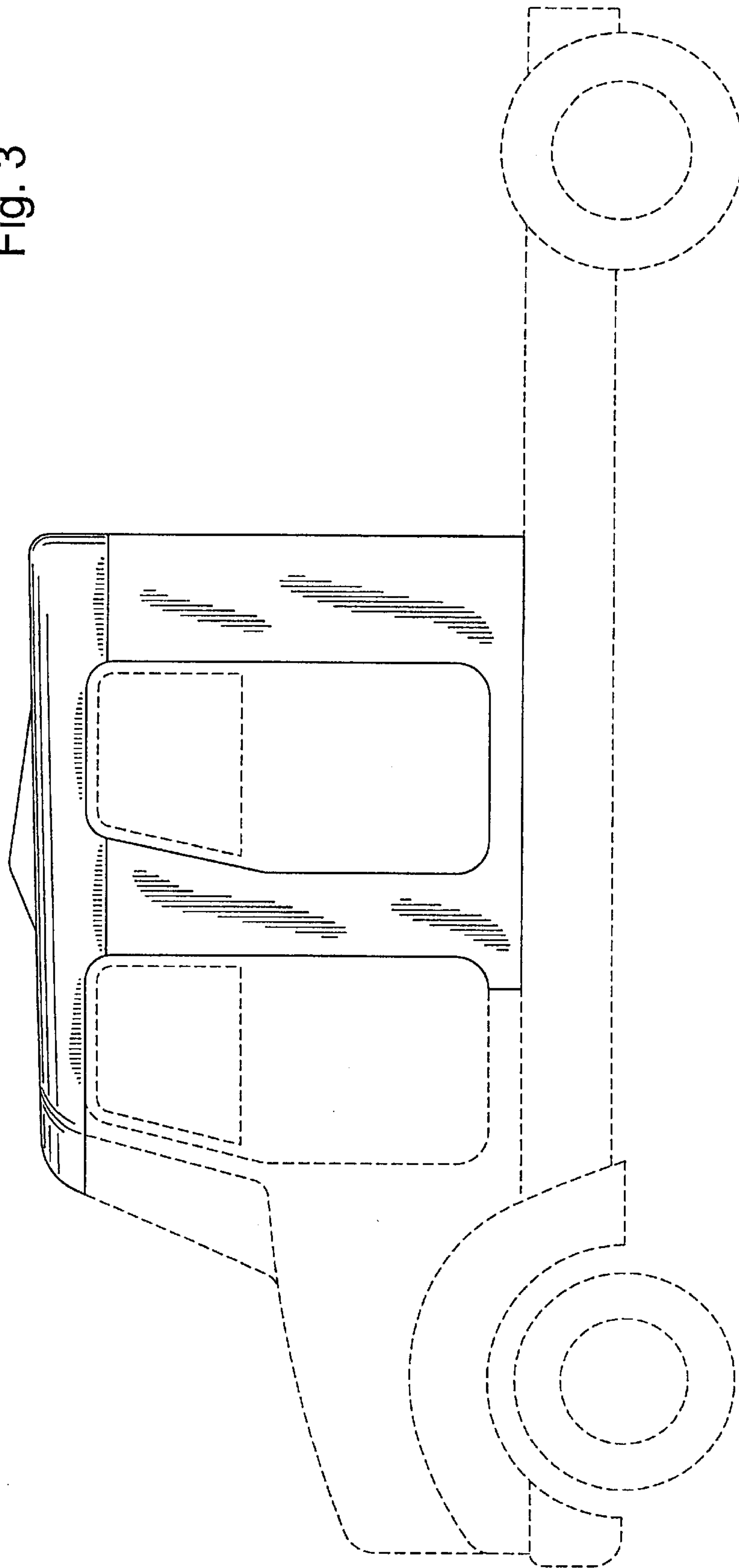
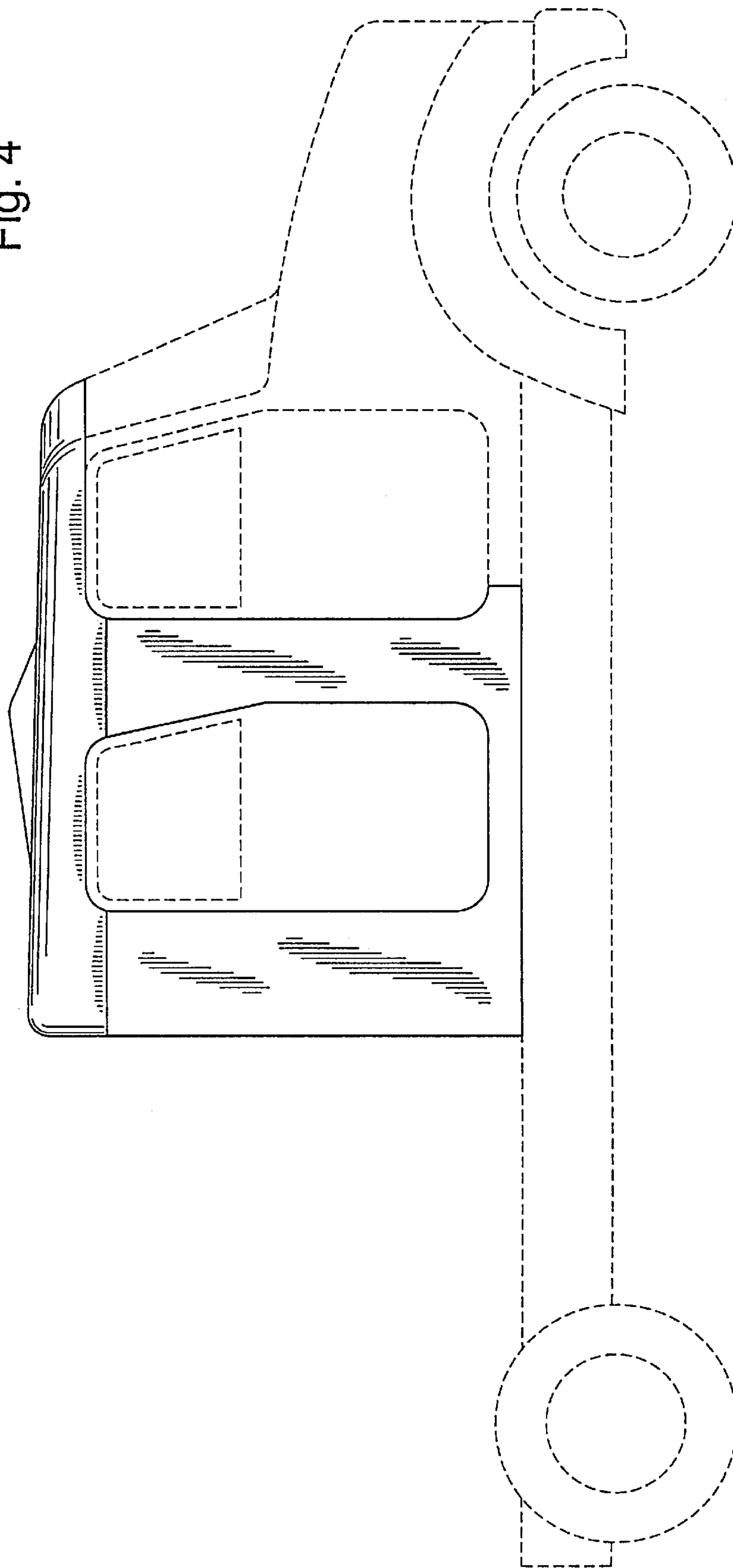

Fig. 4



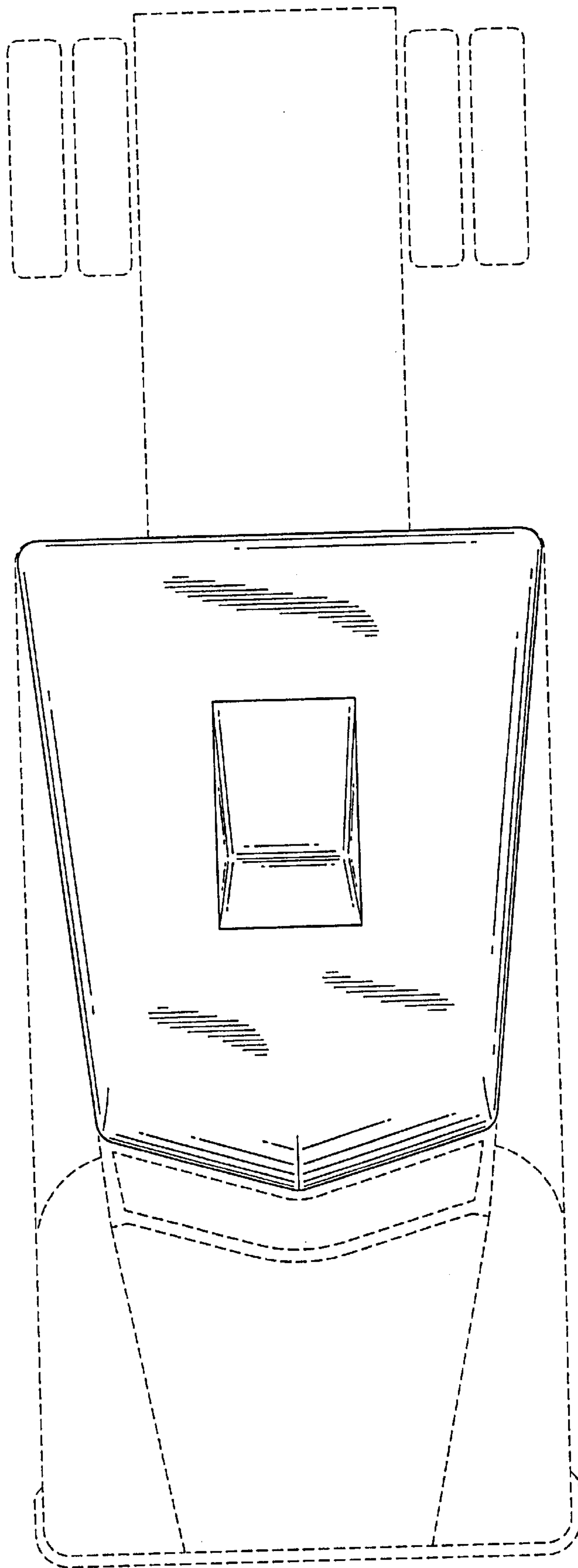

Fig. 5