



US00D432460S

United States Patent [19] Huang

[11] Patent Number: **Des. 432,460**

[45] Date of Patent: **** Oct. 24, 2000**

[54] **GOLF CART**

[76] Inventor: **Webster Huang**, 1F, No. 61, Lane 167,
Tzu-Hsiou N. Rd., Chang-Hua City,
Taiwan

[**] Term: **14 Years**

[21] Appl. No.: **29/120,343**

[22] Filed: **Mar. 16, 2000**

[51] **LOC (7) Cl.** **12-02**

[52] **U.S. Cl.** **D12/16**

[58] **Field of Search** D12/1, 16; 280/DIG. 5,
280/DIG. 6; 296/186; D34/15; 180/6.5,
89.1

[56] **References Cited**

U.S. PATENT DOCUMENTS

D. 188,718	8/1960	Laher	D12/16
D. 195,767	7/1963	MacMinn	D12/16
D. 236,098	7/1975	Bedel	D12/16
D. 245,592	8/1977	Davidson	D12/16
D. 255,558	6/1980	Ekuan	D12/16
D. 320,580	10/1991	Kim	D12/16
D. 326,831	6/1992	Lanius et al.	D12/16
D. 369,762	5/1996	Molzon et al.	D12/16

D. 373,099	8/1996	Molzon et al.	D12/16
D. 377,325	1/1997	Brown et al.	D12/16
D. 393,511	4/1998	Albertsson	D12/16 X
D. 395,023	6/1998	Hikida	D12/16
4,037,614	7/1977	Hines et al.	280/DIG. 5

Primary Examiner—Stacia Cadmus
Attorney, Agent, or Firm—Skjerven Morrill MacPherson
LLP; Alan H. MacPherson

[57] **CLAIM**

The ornamental design for a golf cart, as shown and described.

DESCRIPTION

FIG. 1 is a perspective view of golf cart showing my new design;
FIG. 2 is a reduced front elevational view thereof;
FIG. 3 is a reduced rear elevational view thereof;
FIG. 4 is a reduced left side elevational view thereof;
FIG. 5 is a reduced right side elevational view thereof;
FIG. 6 is a reduced top plan view thereof; and,
FIG. 7 is a reduced bottom plan view thereof.
The broken line showing of environment is for illustrative purposes only and forms no part of the claimed design.

1 Claim, 4 Drawing Sheets





FIG. 1

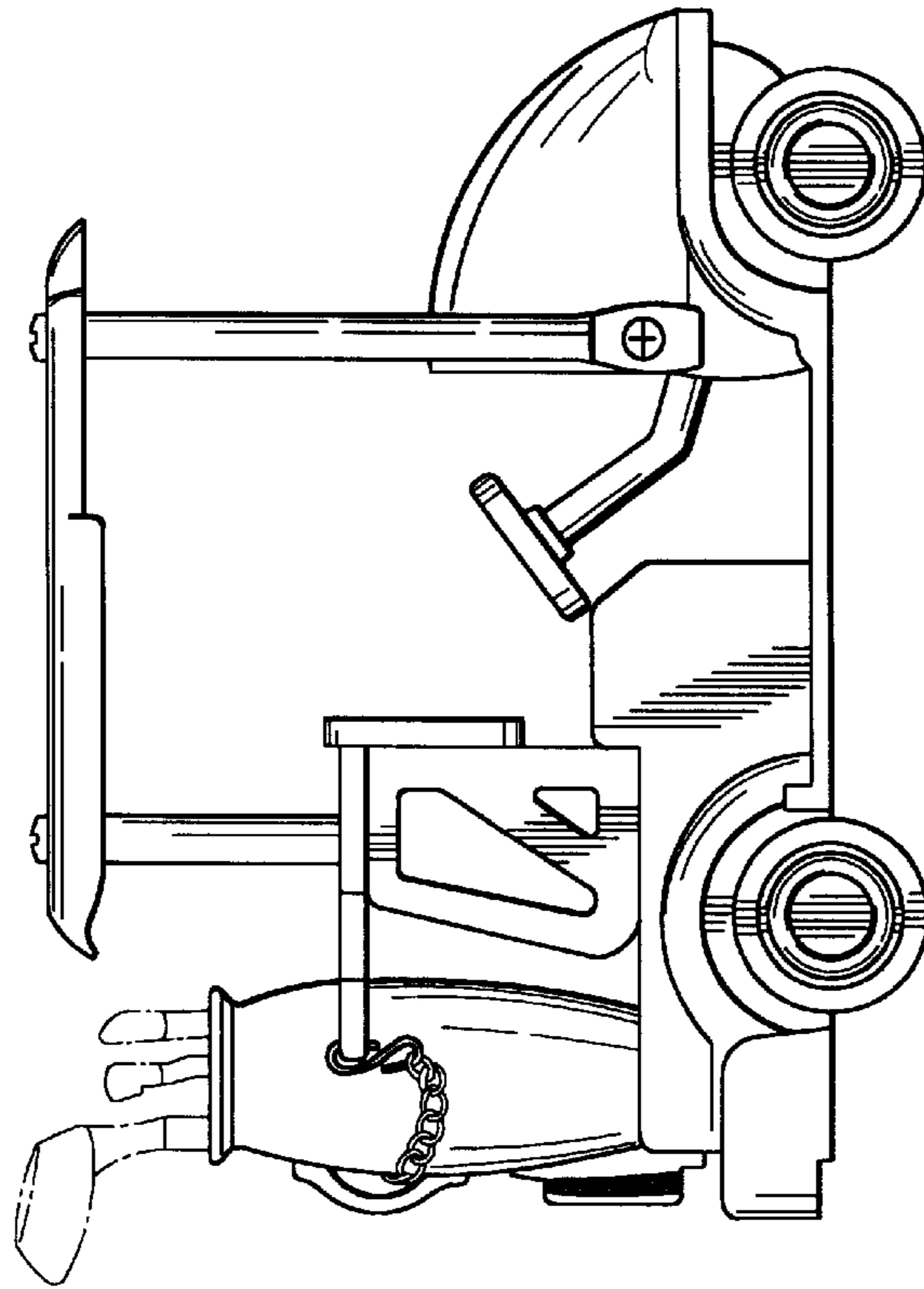

FIG. 3

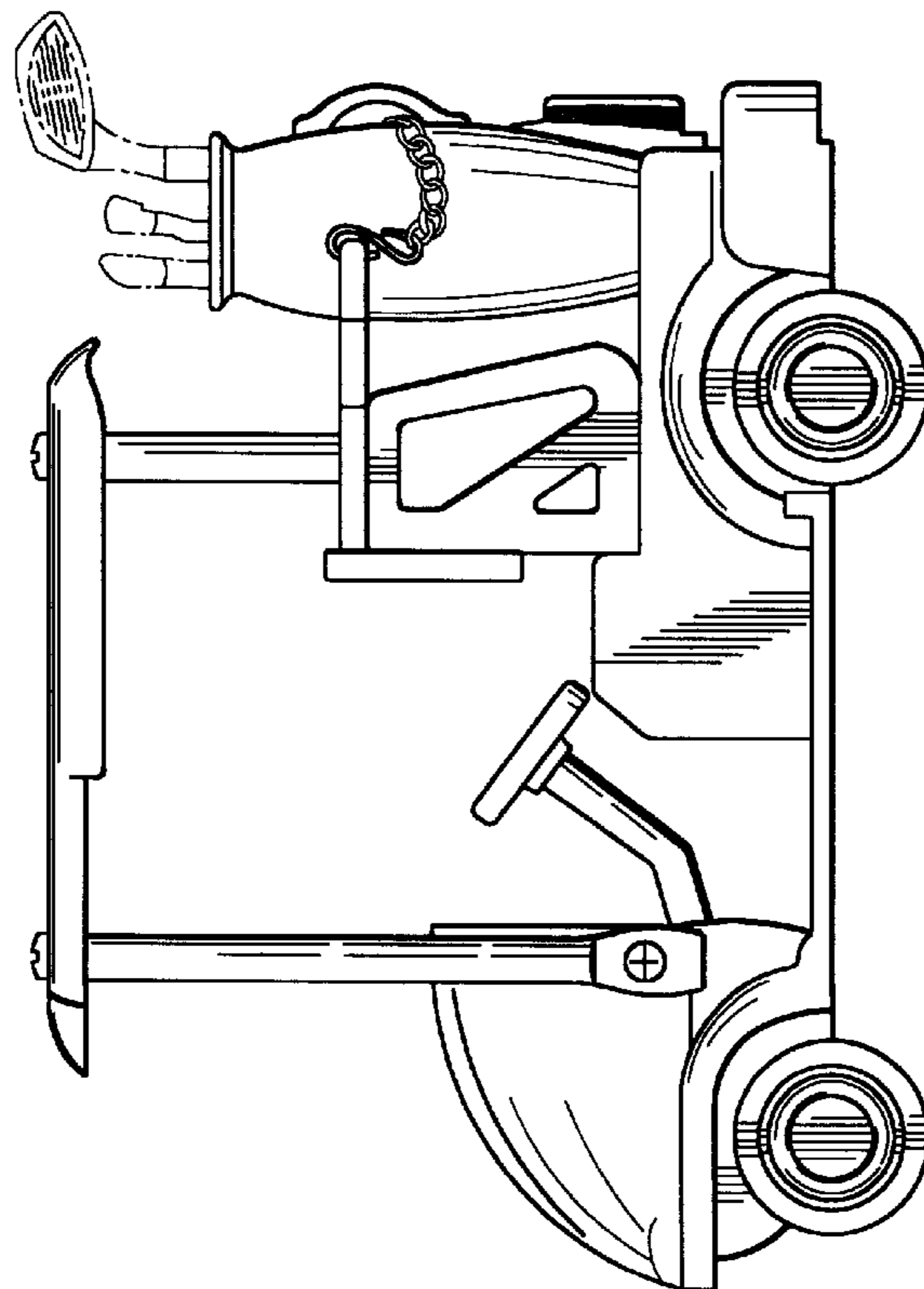

FIG. 2

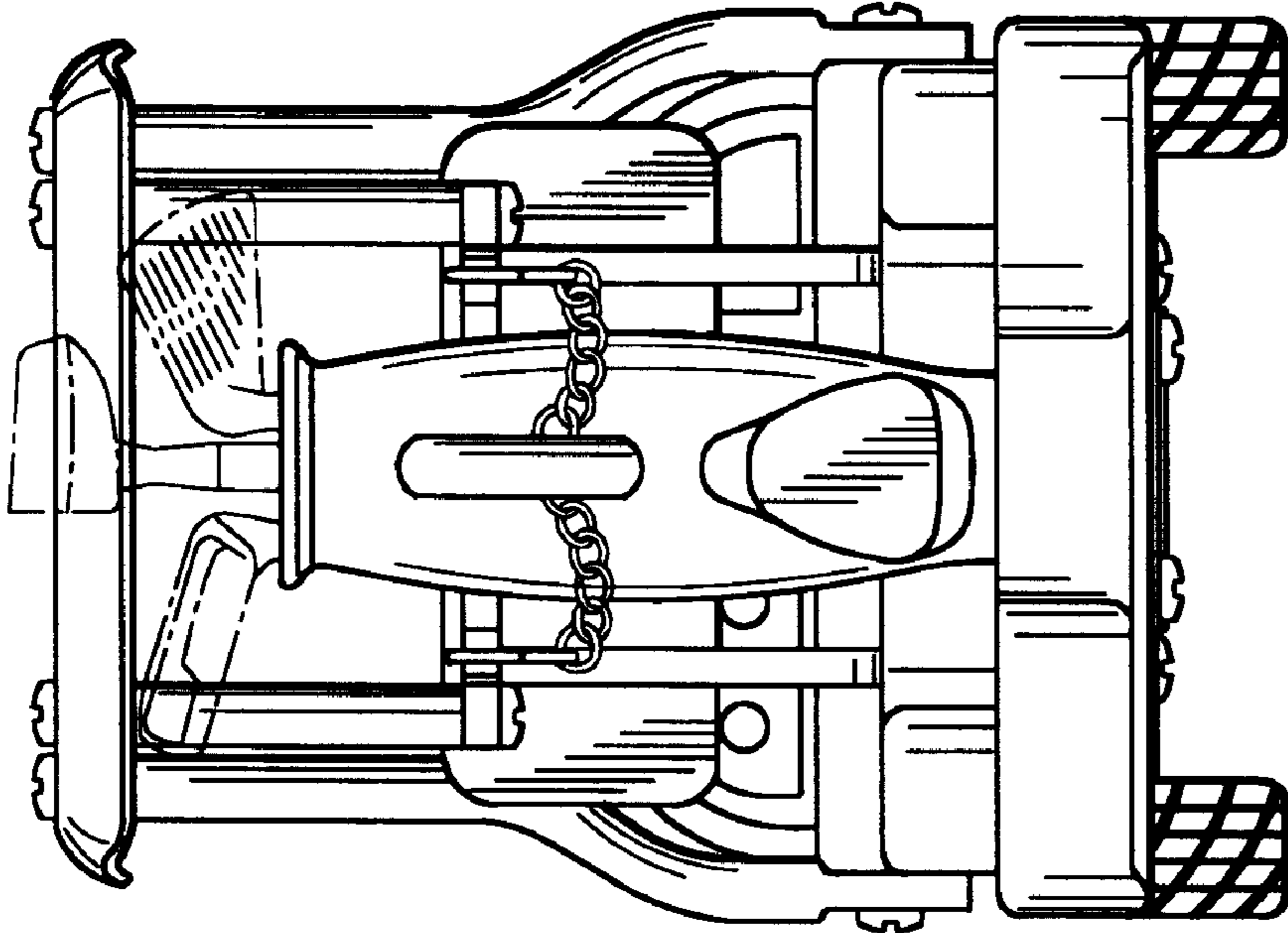

FIG. 5

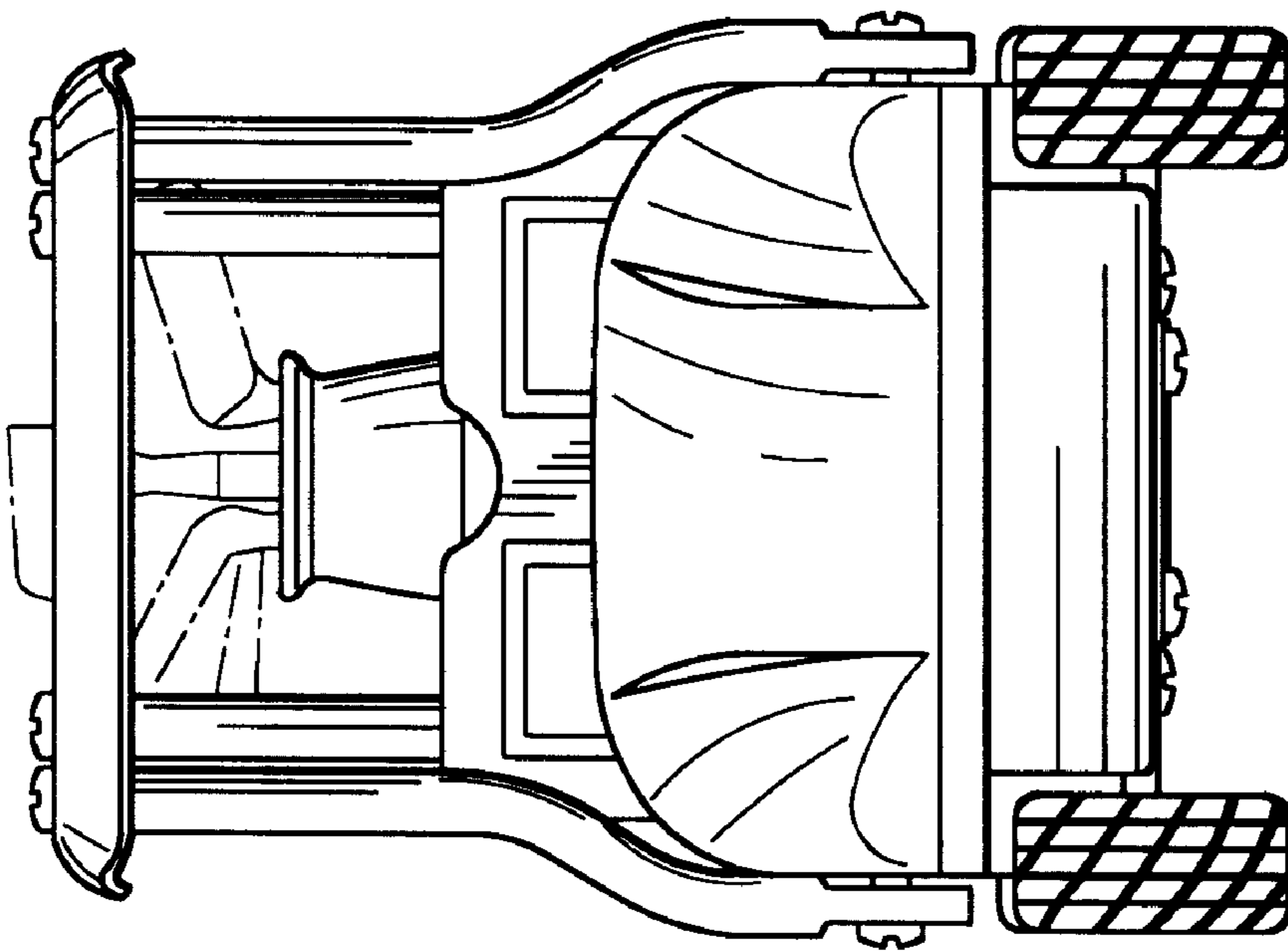

FIG. 4

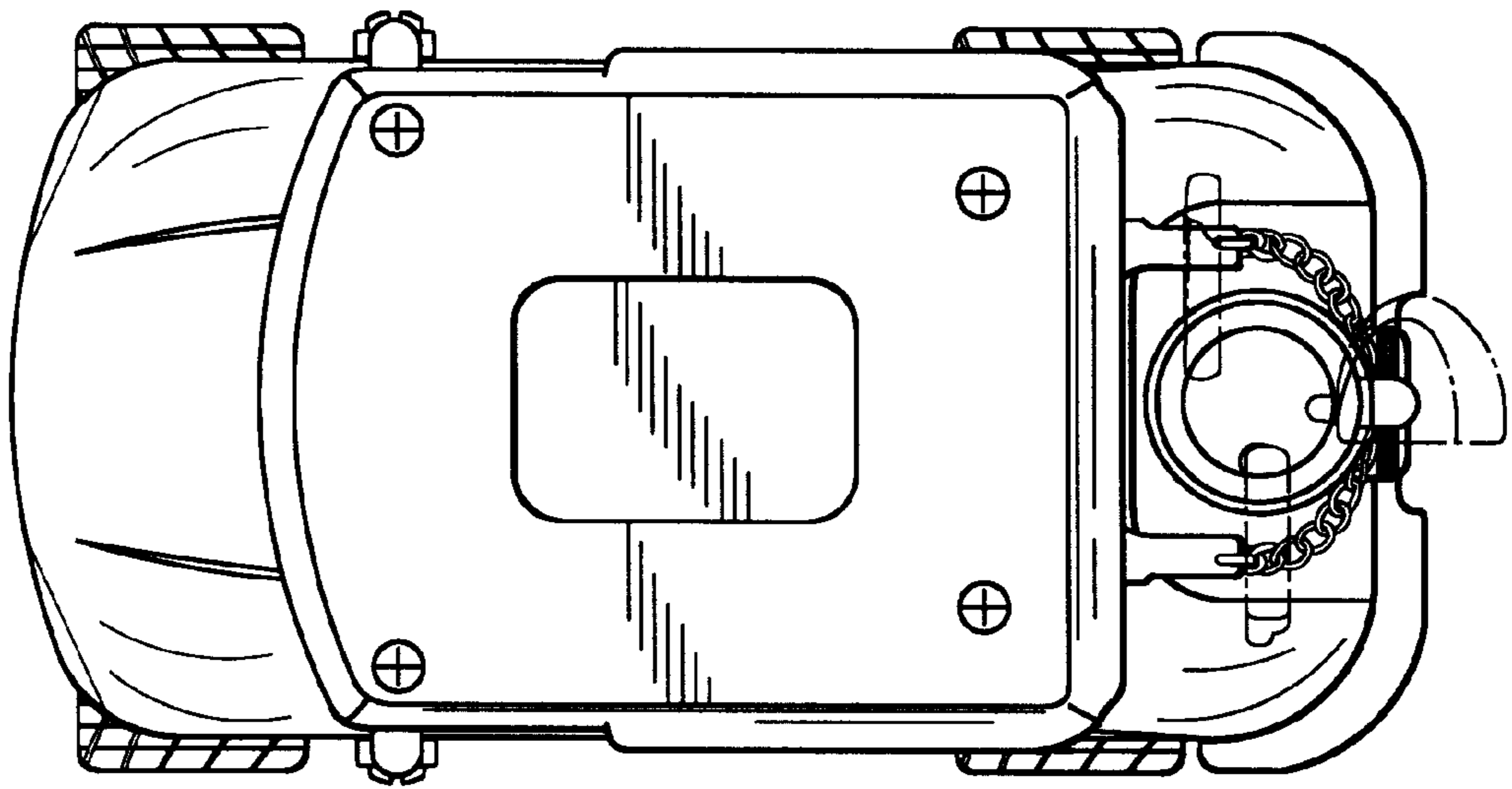

FIG. 6

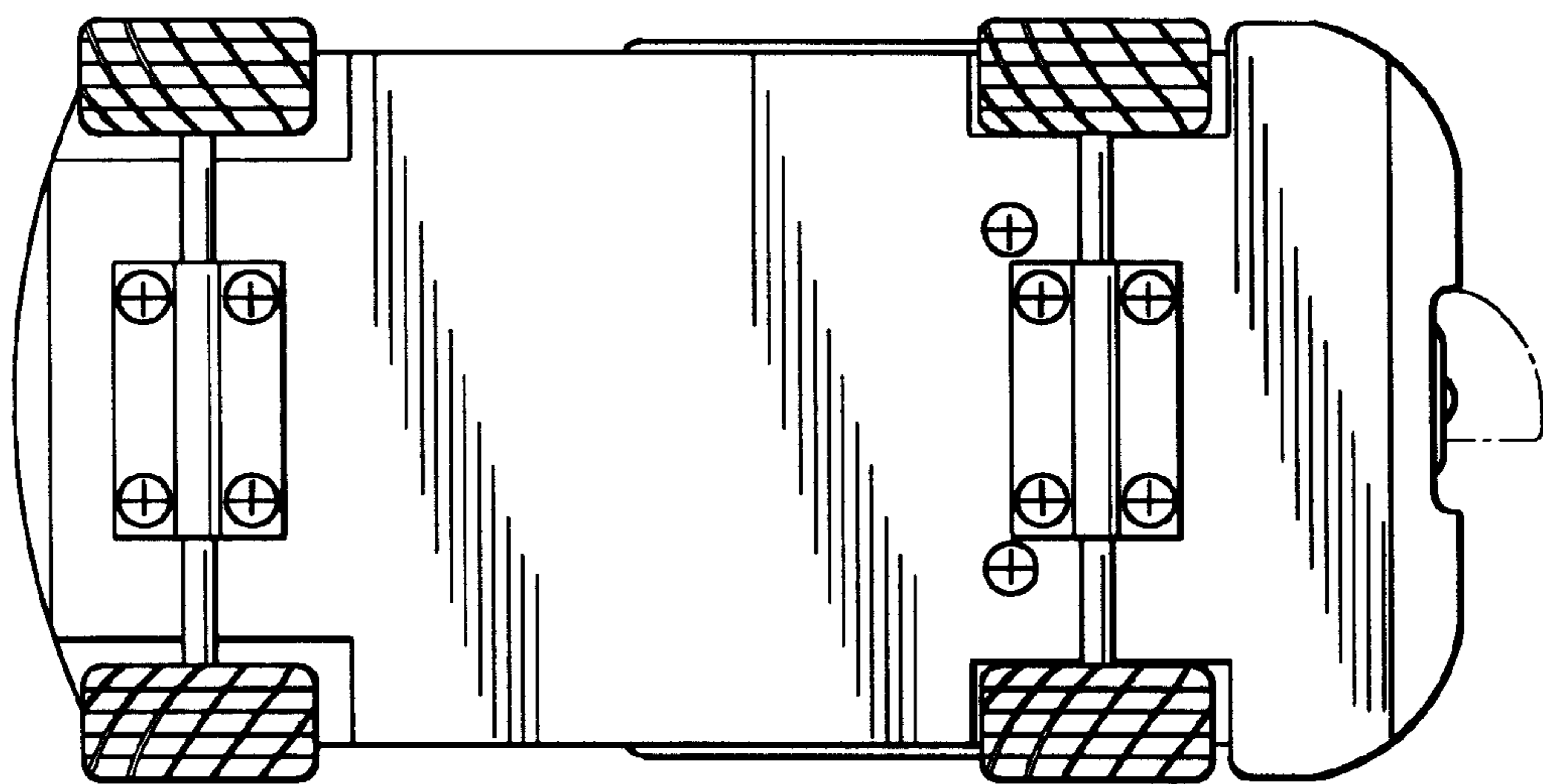

FIG. 7