



US00D432459S

United States Patent [19]
Miller

[11] **Patent Number: Des. 432,459**

[45] **Date of Patent: ** Oct. 24, 2000**

[54] **AMPHIBIOUS ALL TERRAIN VEHICLE**

[76] **Inventor: Patrick F. Miller, 311 S. Cherry St.,
Townsend, Mont. 59644**

[**] **Term: 14 Years**

[21] **Appl. No.: 29/119,316**

[22] **Filed: Feb. 25, 2000**

[51] **LOC (7) Cl. 12-14**

[52] **U.S. Cl. D12/3**

[58] **Field of Search D12/1-3, 12-14,
D12/86, 83, 300, 306, 315; 180/9.1, 182,
89.1, 6.48, 333; 280/829; 296/185; 114/270;
440/12.53**

[56] **References Cited**

U.S. PATENT DOCUMENTS

D. 217,056	3/1970	Gamaunt	D12/3
D. 220,874	6/1971	Rogers et al.	D12/3
D. 297,825	9/1988	Duff	D12/3
D. 305,877	2/1990	Price, II	D12/3
D. 332,764	1/1993	Chandler	D12/3

D. 356,056	3/1995	Wardavoir	D12/3
D. 391,896	3/1998	Albertson	D12/3
3,741,146	6/1973	Durrell, Jr.	440/12.53
3,771,615	11/1973	Reili	180/6.48

Primary Examiner—Stacia Cadmus
Attorney, Agent, or Firm—Jerry Johnson

[57] **CLAIM**

The ornamental design for an amphibious all terrain vehicle, as shown and described.

DESCRIPTION

FIG. 1 is a perspective view of an amphibious all terrain vehicle showing my new design;
FIG. 2 is an enlarged left side elevational view thereof;
FIG. 3 is an enlarged right side elevational view thereof;
FIG. 4 is an enlarged top plan view thereof;
FIG. 5 is an enlarged bottom plan view thereof;
FIG. 6 is an enlarged front elevational view thereof; and,
FIG. 7 is an enlarged rear elevational view thereof.
The broken line showing of environment is for illustrative purposes only and forms no part of the claimed design.

1 Claim, 3 Drawing Sheets

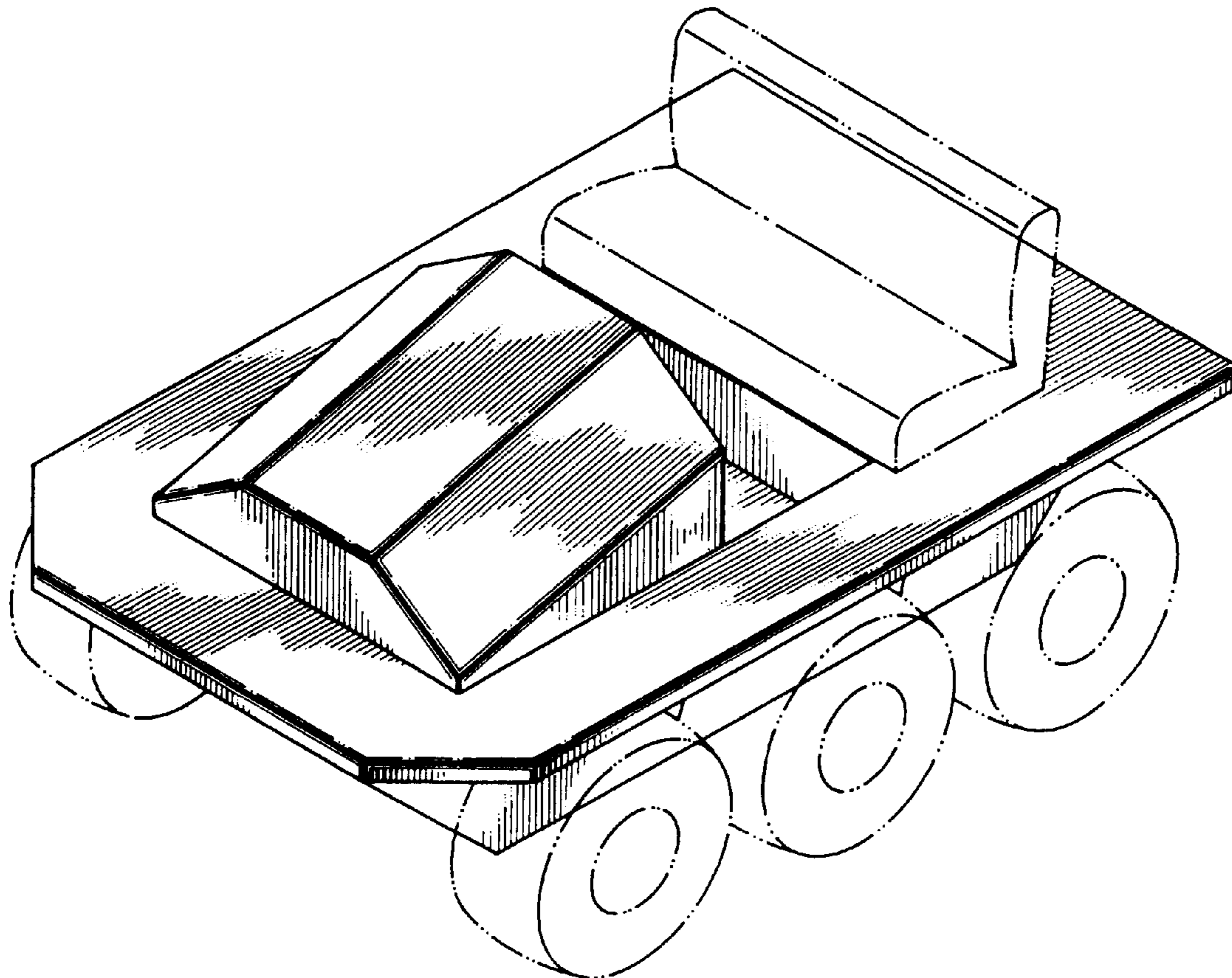

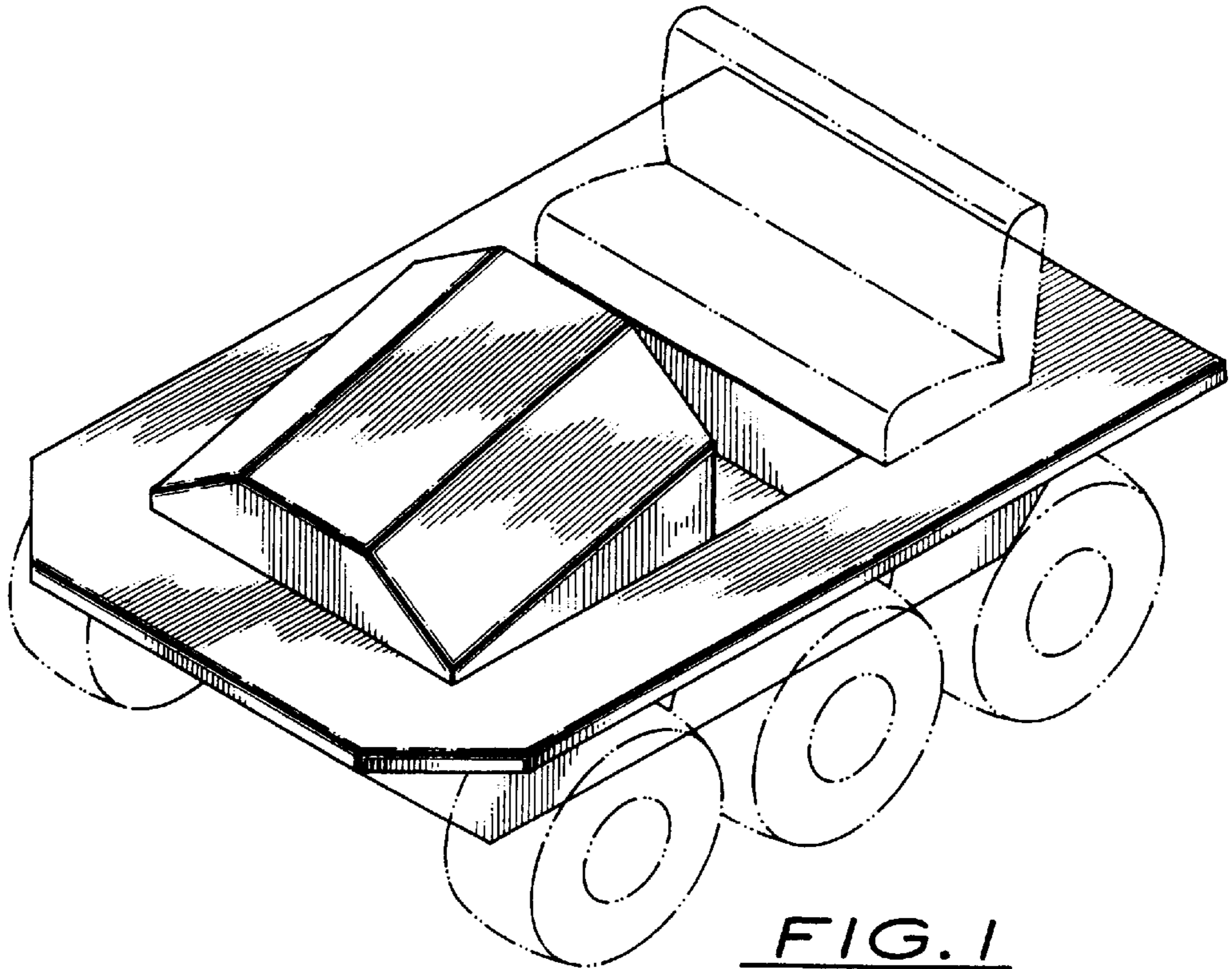

FIG. 1

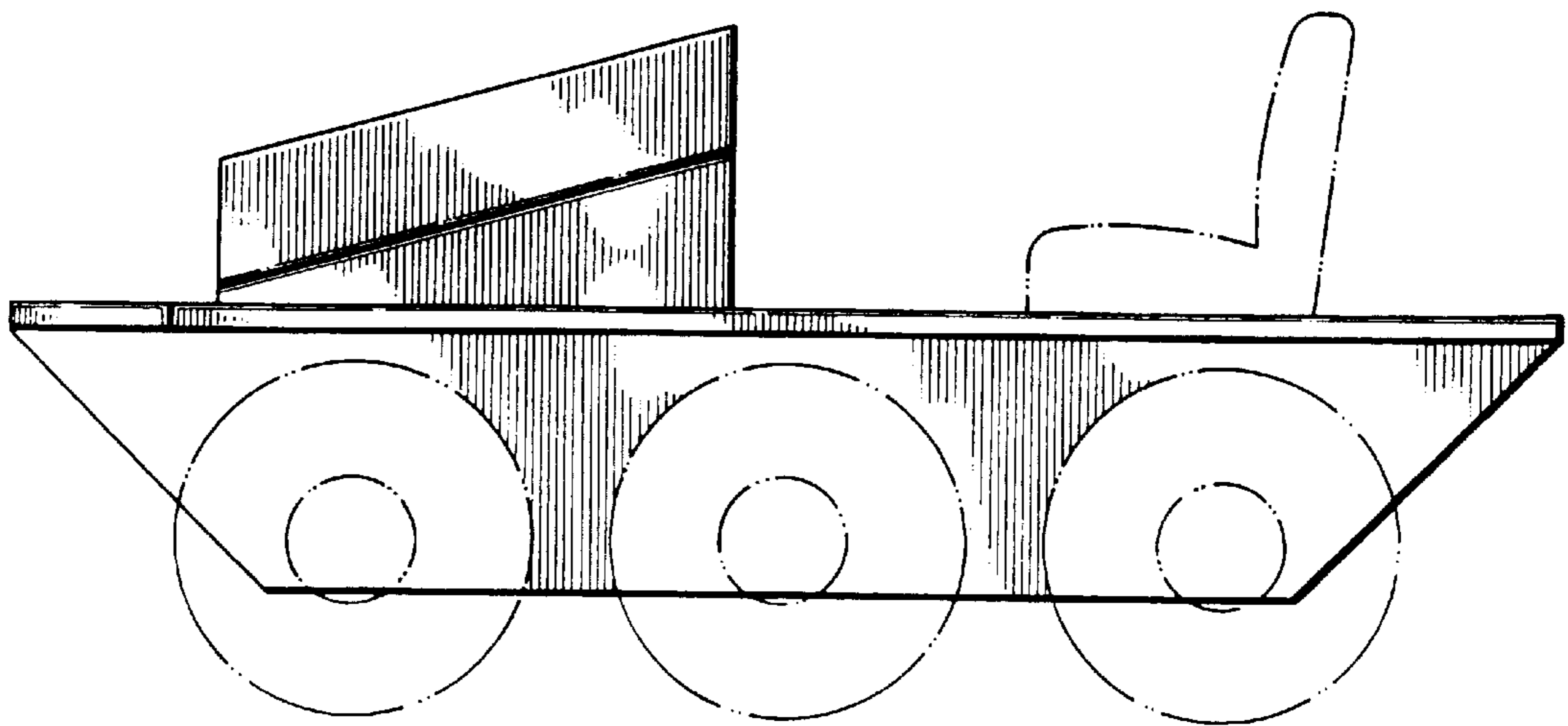

FIG. 2

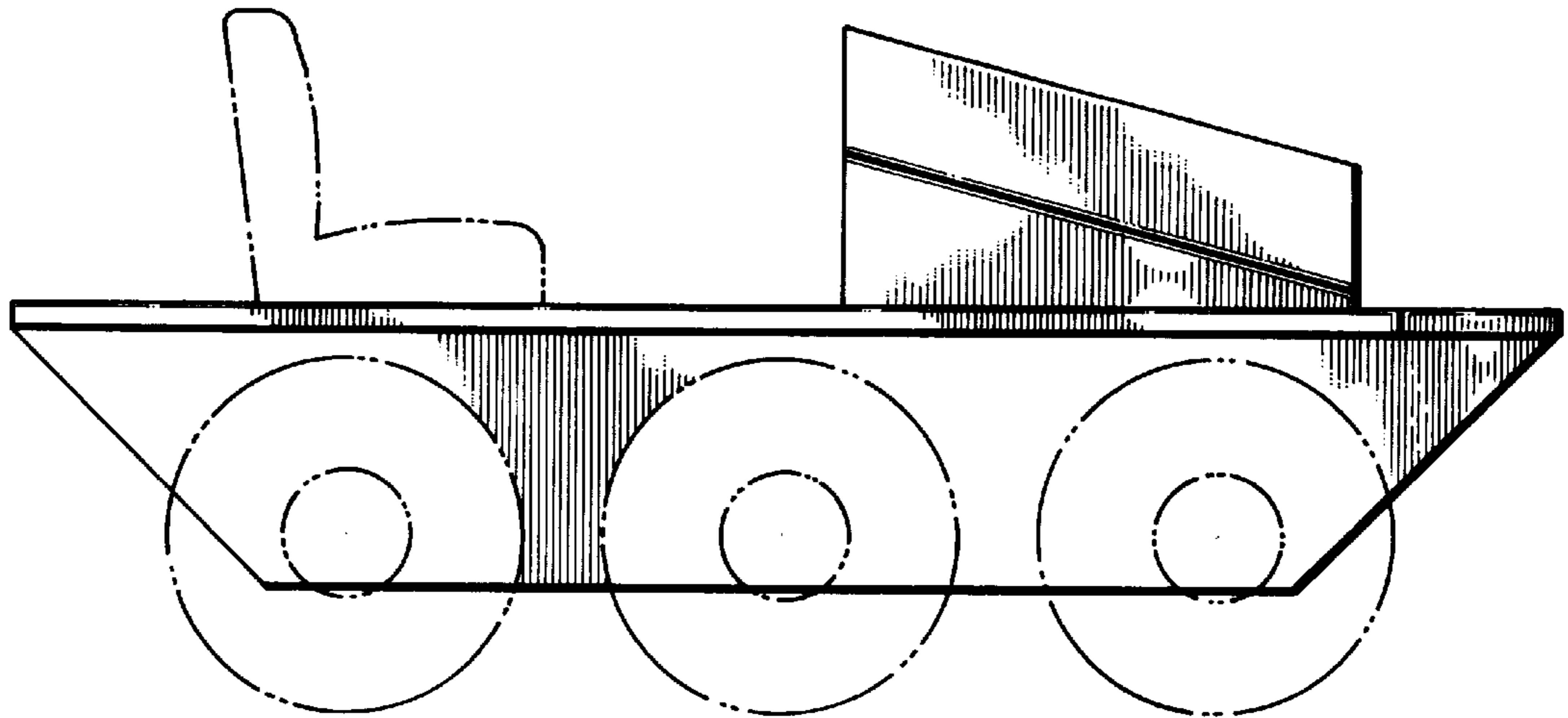

FIG. 3

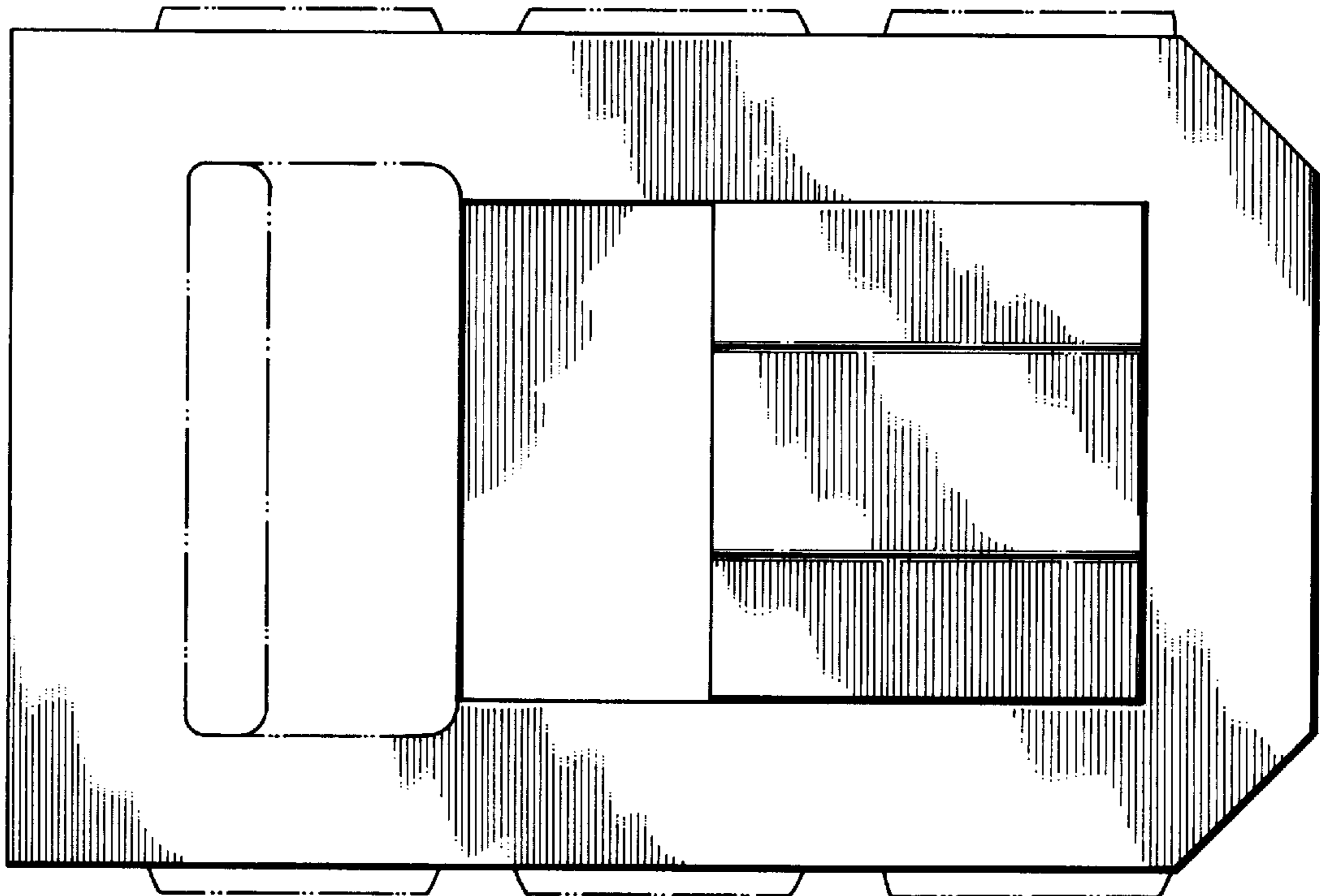

FIG. 4

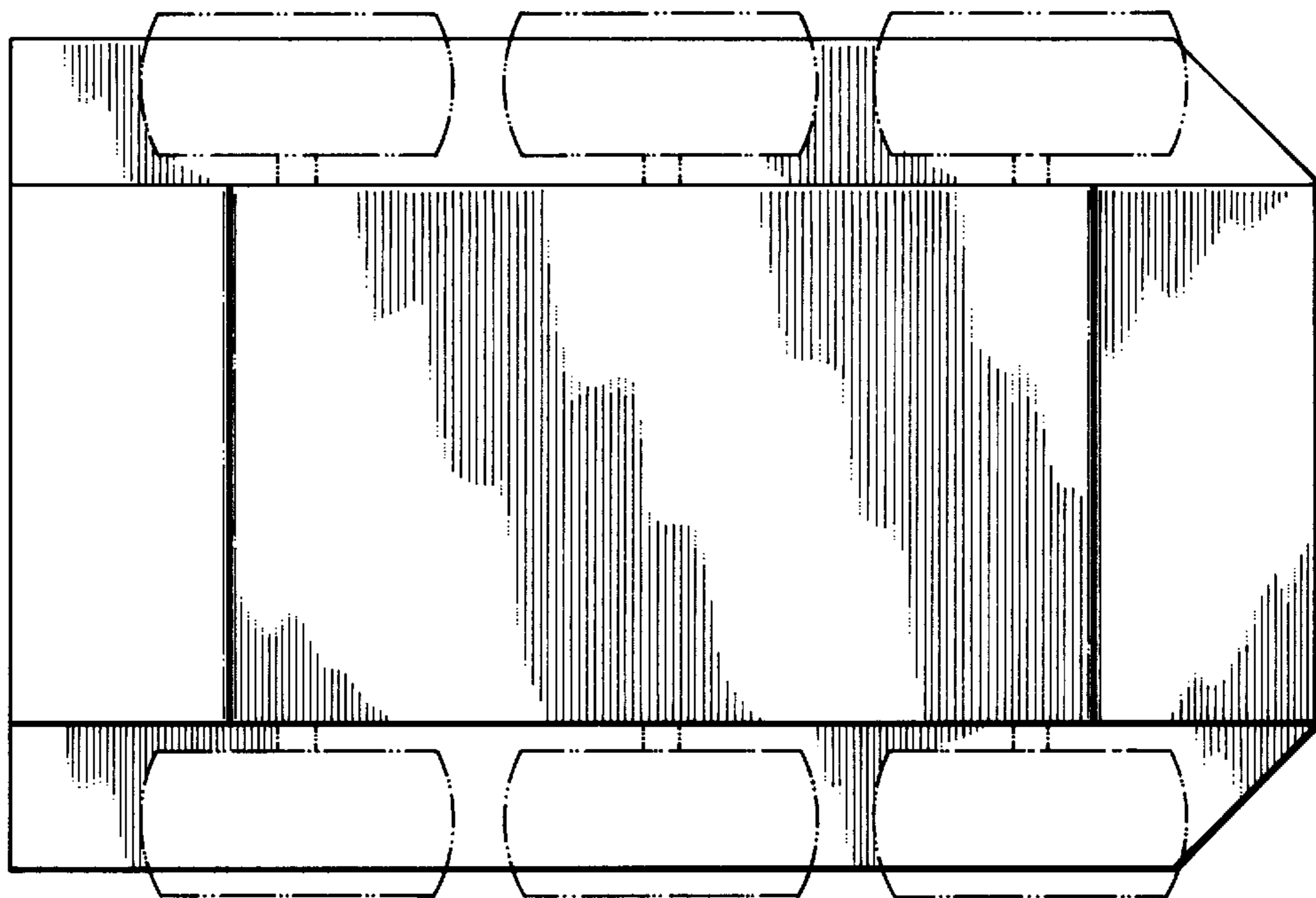

FIG. 5

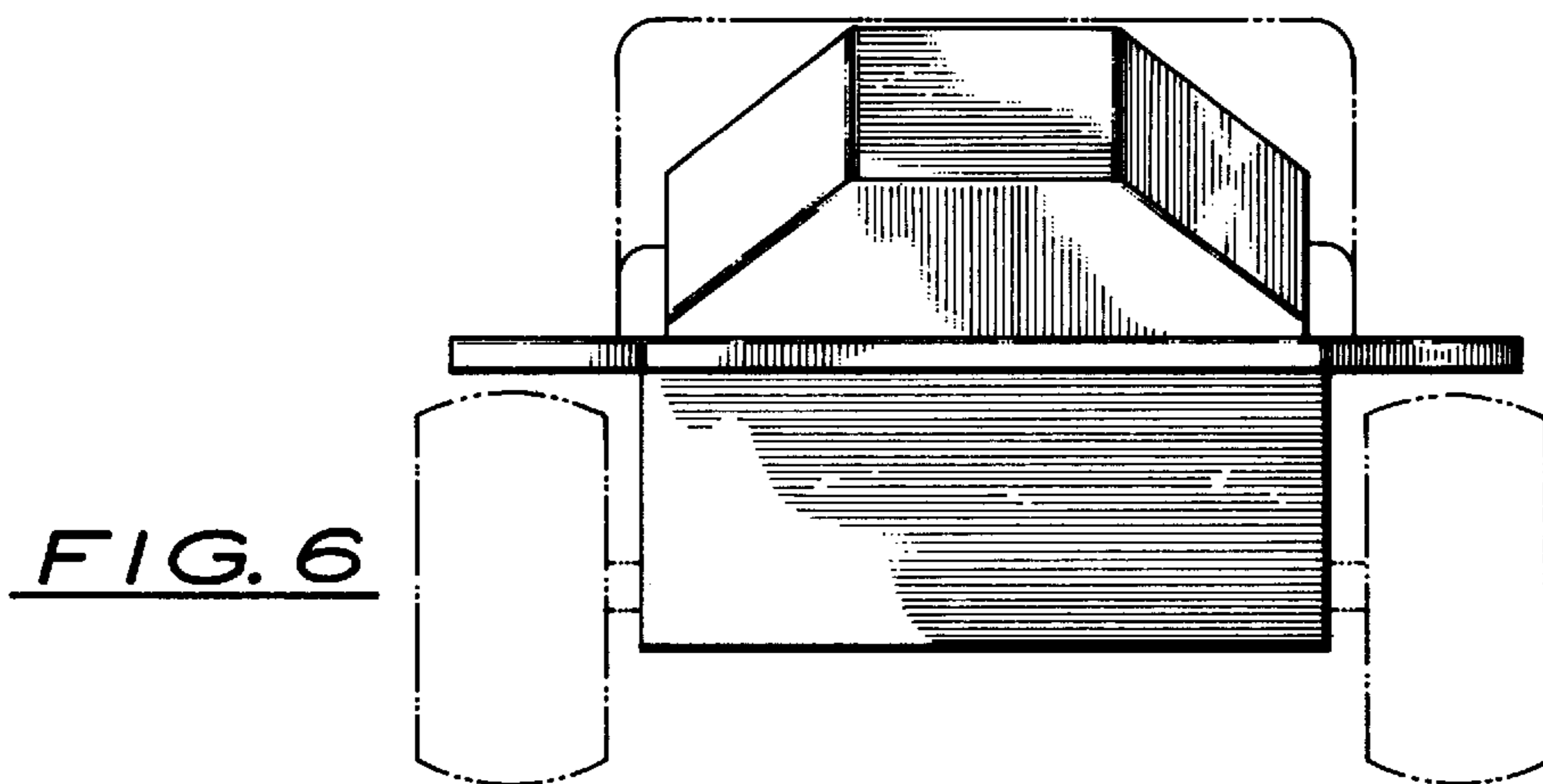

FIG. 6

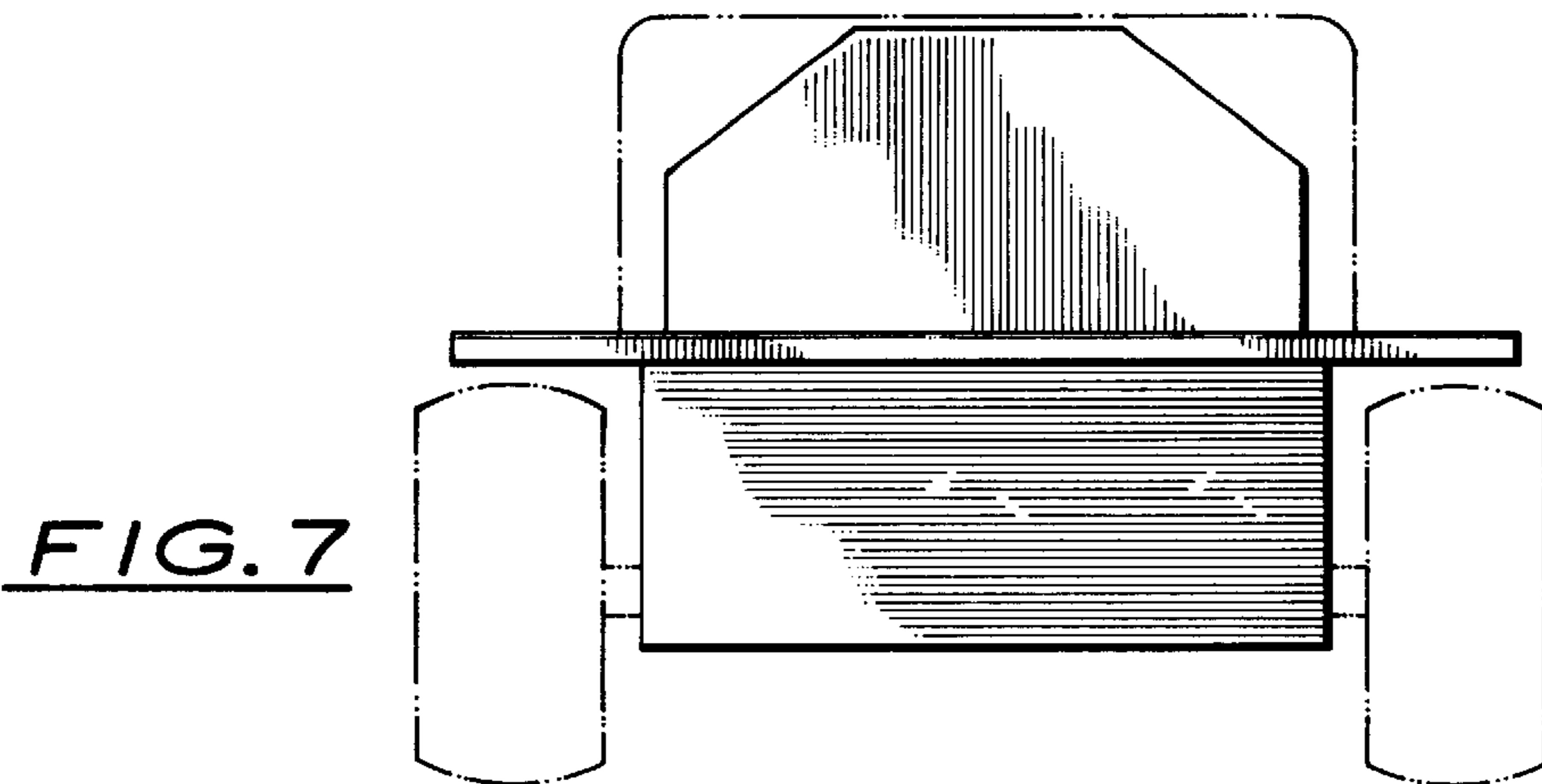

FIG. 7