



US00D432409S

# United States Patent [19] Feldmeier

[11] Patent Number: **Des. 432,409**

[45] Date of Patent: **\*\* Oct. 24, 2000**

[54] **FOOD PACKAGE TRAY**

[75] Inventor: **Daniel R. Feldmeier**, Waunakee, Wis.

[73] Assignee: **Kraft Foods, Inc.**, Northfield, Ill.

[\*\*] Term: **14 Years**

[21] Appl. No.: **29/099,442**

[22] Filed: **Jan. 21, 1999**

[51] **LOC (7) Cl.** ..... **09-03**

[52] **U.S. Cl.** ..... **D9/341; D9/347**

[58] **Field of Search** ..... D7/545, 549, 553.2,  
D7/555, 556, 587, 602-604, 612-615, 629,  
509, 523, 543; D9/337, 341, 345-347,  
420-421, 430-432, 425, 414, 415; 206/562-564;  
220/527-528, 556-557; 229/407

[56] **References Cited**

**U.S. PATENT DOCUMENTS**

D. 183,047	6/1958	Helmer .	
D. 185,911	8/1959	Chadbourne .....	D7/555
D. 196,854	11/1963	Nicholson .	
D. 206,762	1/1967	Kirwan .	
D. 211,697	7/1968	Collie .	
D. 213,491	3/1969	Beeman et al. .	
D. 213,492	3/1969	Beeman et al. .	
D. 235,499	6/1975	Brantford .....	D7/553.3
D. 247,124	1/1978	Beecher .	
D. 258,632	3/1981	Commisso .	
D. 268,645	4/1983	Phillips et al. .	
D. 273,363	4/1984	Hagedorn et al. .	

D. 280,290	8/1985	Bakus .	
D. 283,666	5/1986	Holzkopf .	
D. 305,002	12/1989	Hayes et al. .	
D. 318,207	7/1991	Anderson .....	D7/553.2
D. 334,536	4/1993	Long et al. .	
D. 339,522	9/1993	Zoss .	
D. 352,203	11/1994	Campbell et al. ....	D7/553.2
D. 376,953	12/1996	Dunn .....	D7/549
D. 388,699	1/1998	Hayes et al. ....	D9/341
D. 395,003	6/1998	Daniels .	
D. 414,409	9/1999	Sanfilippo et al. ....	D9/341
4,219,144	8/1980	Hagelberg .....	229/406
5,152,398	10/1992	Forestal et al. .	
5,236,119	8/1993	Chu .	
5,323,928	6/1994	Stevens .	
5,803,305	9/1998	Perlis et al. .	

*Primary Examiner*—James Gandy  
*Assistant Examiner*—Carol Rademaker

[57] **CLAIM**

The ornamental design for a food package tray, as shown and described.

**DESCRIPTION**

FIG. 1 is a perspective view of a food package tray showing a preferred embodiment of my new design; FIG. 2 is a front elevational view thereof; FIG. 3 is a right end elevational view thereof; FIG. 4 is a left end elevational view thereof; FIG. 5 is a rear elevational view thereof; FIG. 6 is a top plan view thereof; and, FIG. 7 is a bottom plan view thereof.

**1 Claim, 3 Drawing Sheets**

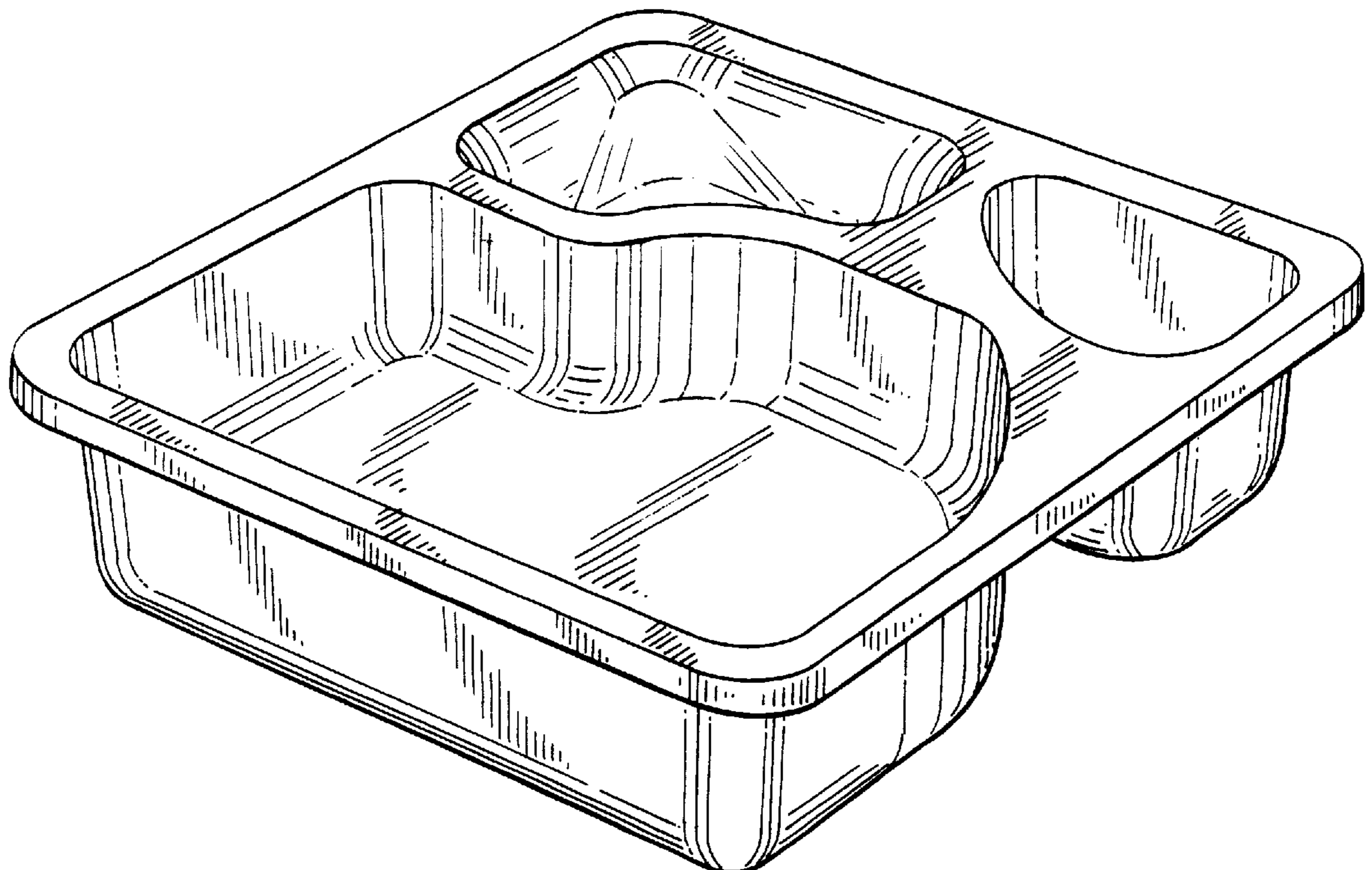

FIG. 1

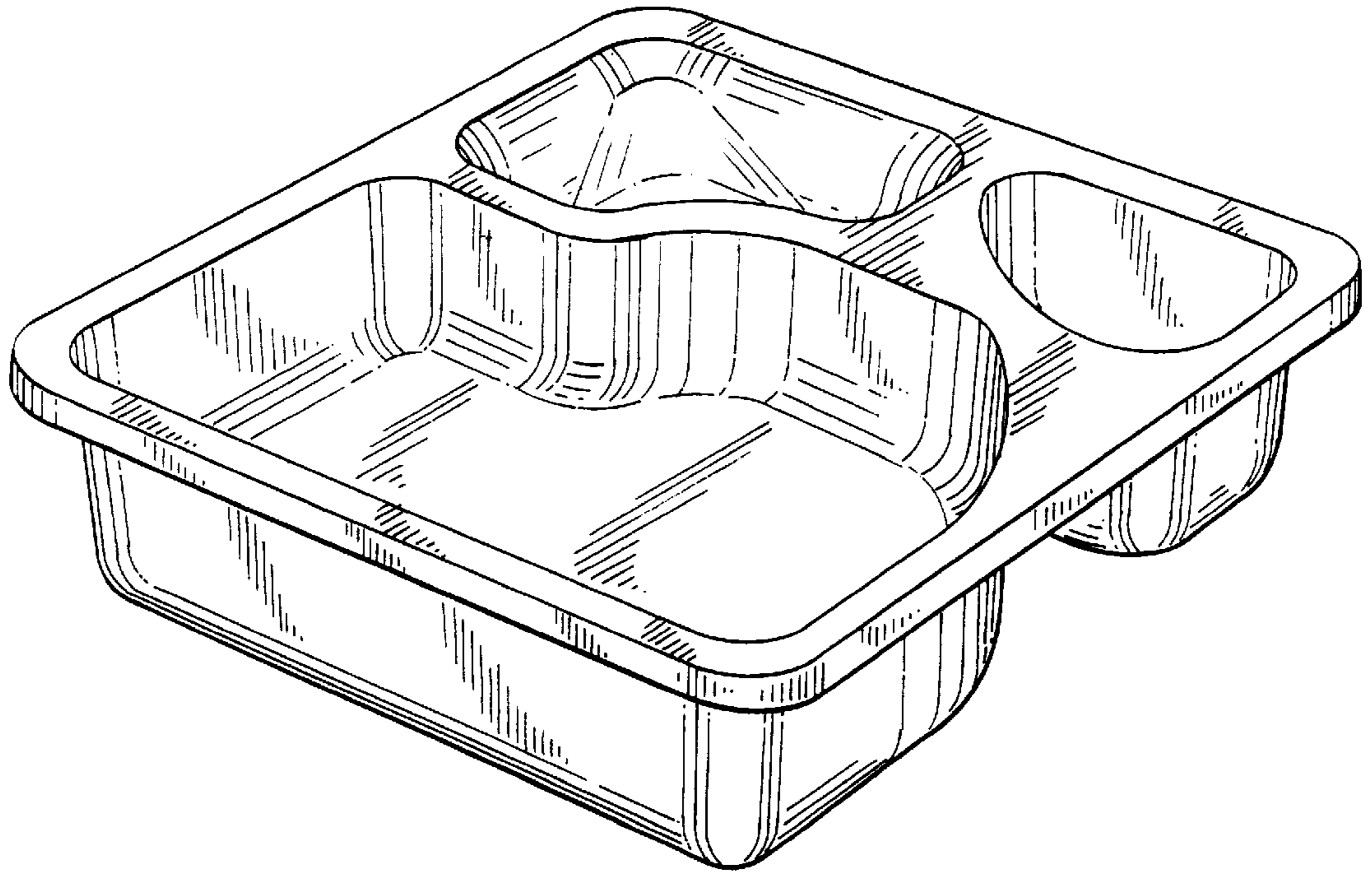

FIG. 2

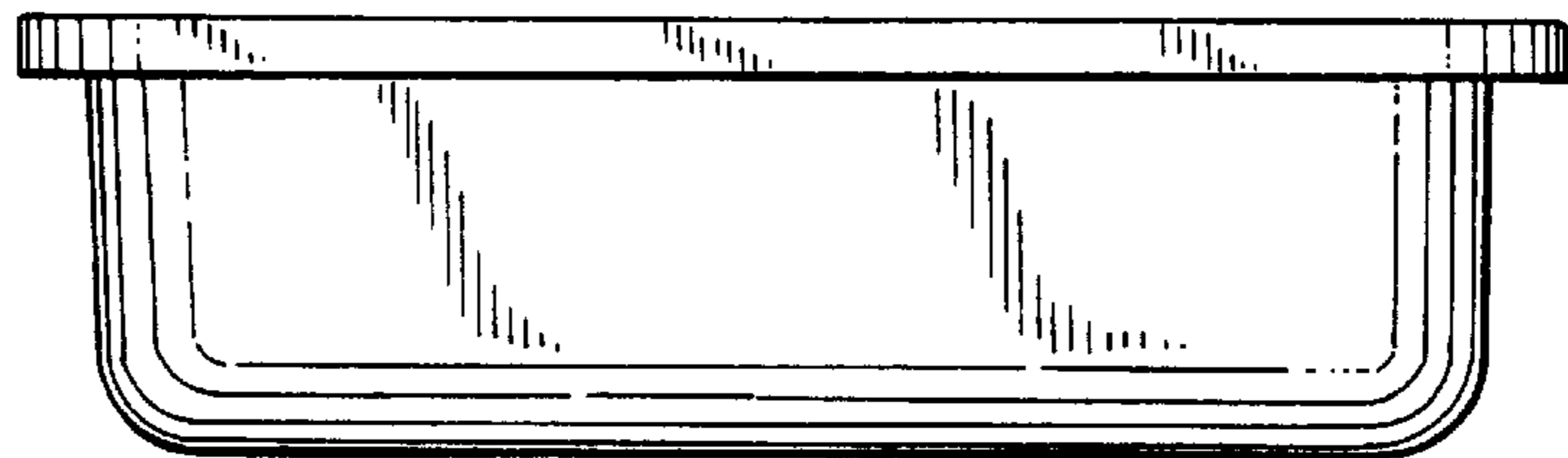

FIG. 3

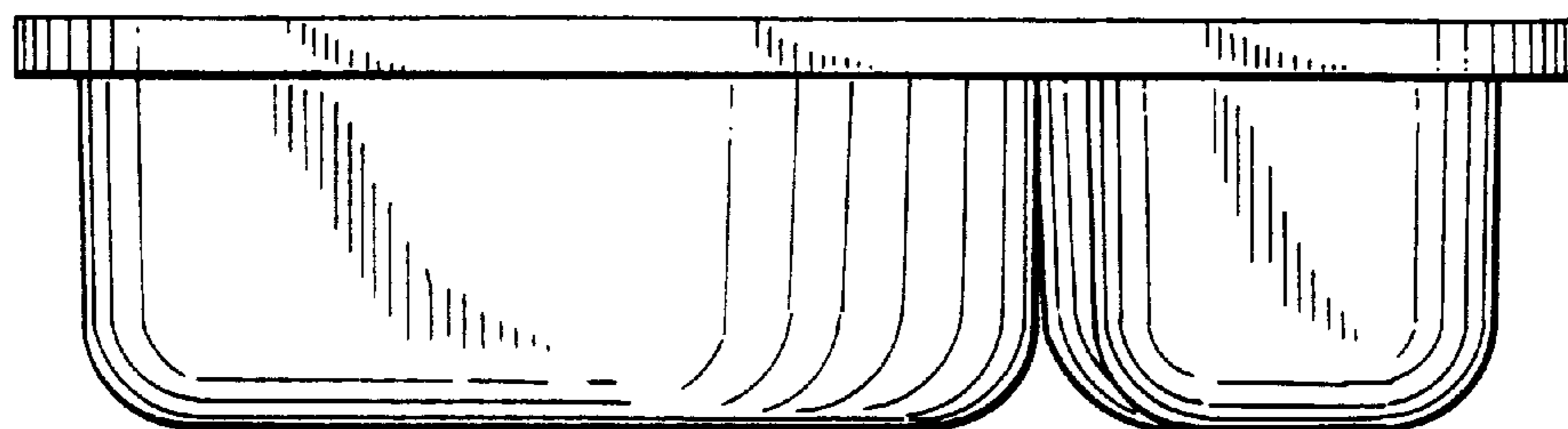

FIG. 4

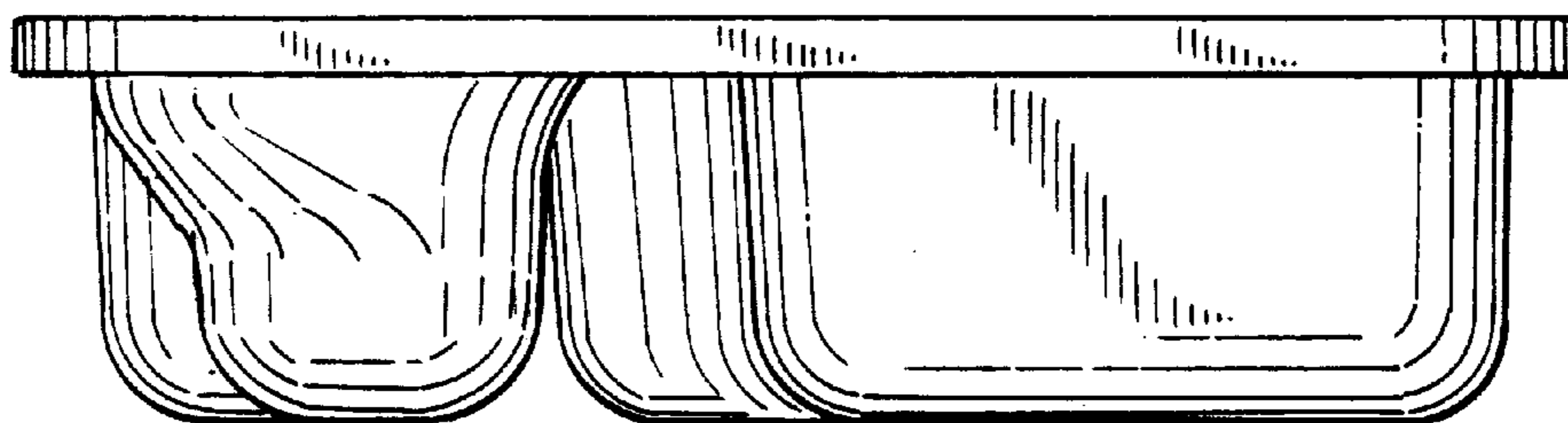

FIG. 5

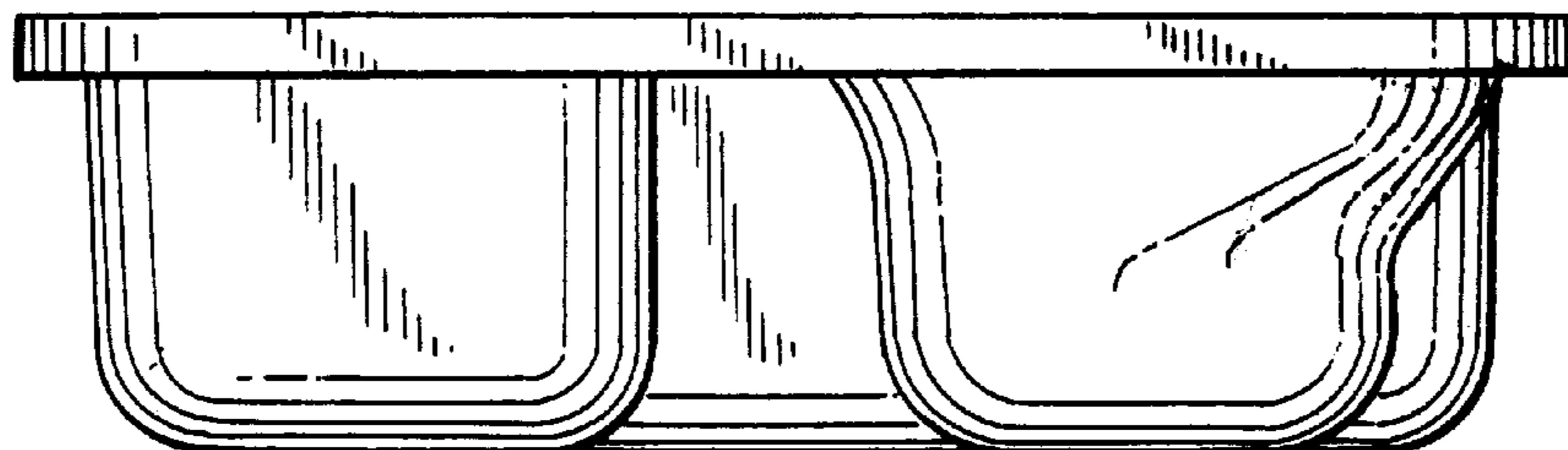

FIG. 6

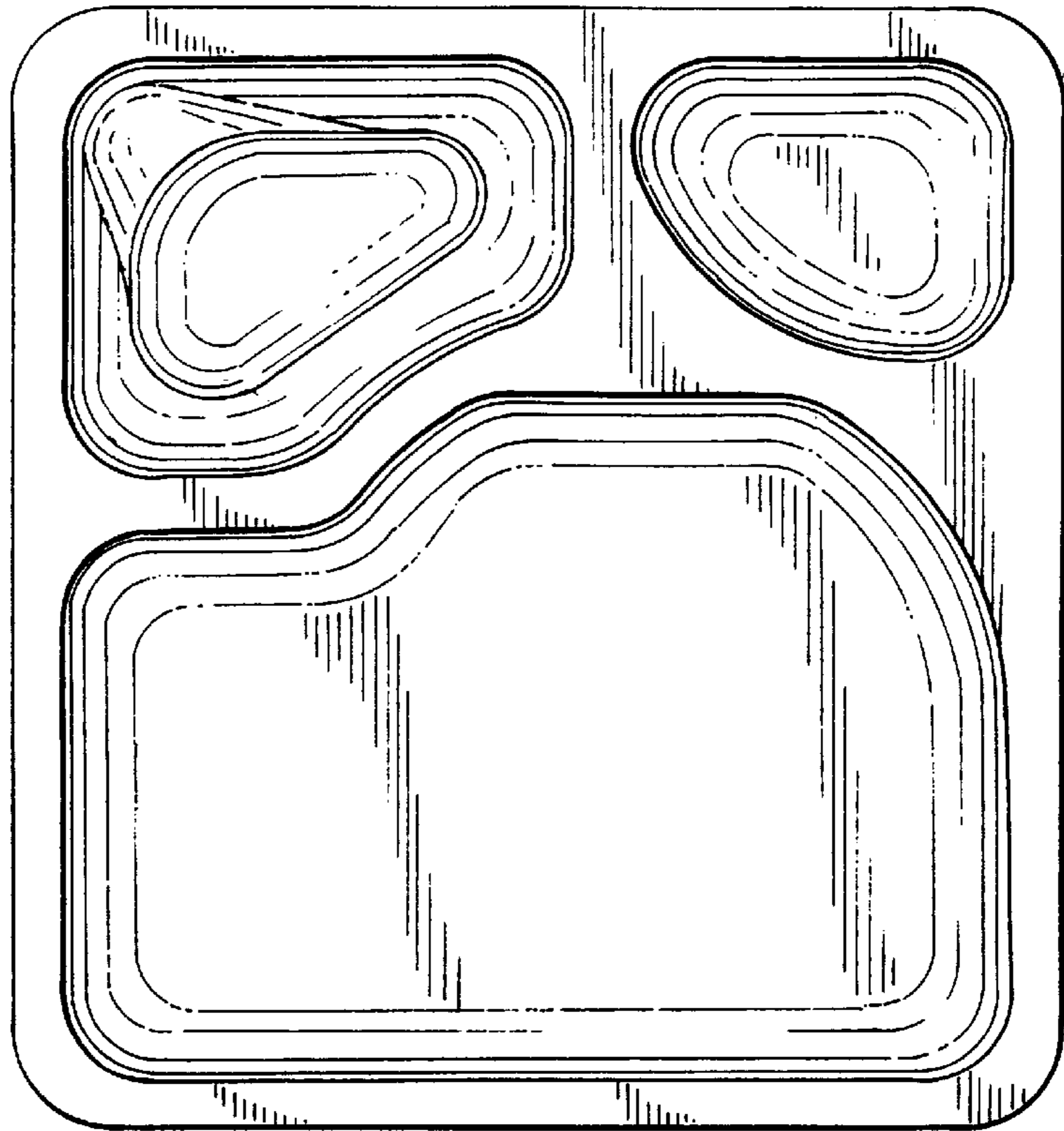

FIG. 7

