



US00D432323S

United States Patent [19]

Pomeroy et al.

[11] Patent Number: Des. 432,323

[45] Date of Patent: ** Oct. 24, 2000

[54] GLIDER

[75] Inventors: Charles Pomeroy; John T. Bycraft, both of South Bend, Ind.

[73] Assignee: Jack-Post Corporation, Buchanan, Mich.

[**] Term: 14 Years

[21] Appl. No.: 29/113,287

[22] Filed: Nov. 2, 1999

[51] LOC (7) Cl. 06-01

[52] U.S. Cl. D6/344

[58] Field of Search D6/334, 335, 344, D6/346, 347, 370, 371, 373, 381, 500, 501, 502; 297/273, 281

[56] References Cited

U.S. PATENT DOCUMENTS

D. 92,012	4/1934	Mcgowen	D6/347
D. 98,065	1/1936	Hardy	D6/347
D. 99,375	4/1936	Spangler	D6/347
D. 135,777	6/1943	Smith	D6/347
D. 153,162	3/1949	Nelems	D6/347
D. 154,356	7/1949	Allmand	D6/347
D. 290,911	7/1987	Pomeroy et al.	D6/347
D. 296,272	6/1988	Colby	D6/347
D. 306,530	3/1990	Vanderminden	D6/347
D. 325,823	5/1992	Pomeroy et al.	D6/335
D. 334,485	4/1993	Pomeroy et al.	D6/344
D. 350,855	9/1994	Pomeroy et al.	D6/344
D. 362,349	9/1995	Pomeroy et al.	D6/344
D. 365,692	1/1996	Pomeroy et al.	D6/344

D. 400,720	11/1998	Pomeroy et al.	D6/344
D. 410,340	6/1999	Pomeroy et al.	D6/344
D. 417,559	12/1999	Pomeroy et al.	D6/344
5,667,273	9/1997	Noll	297/171

Primary Examiner—Doris V. Coles
Assistant Examiner—Mimosa De
Attorney, Agent, or Firm—Jenkins & Gilchrist

[57] CLAIM

The ornamental design for glider, as shown and described.

DESCRIPTION

FIG. 1 is a perspective view of the first embodiment of a glider showing our new design in the form of a settee; FIG. 2 is an end elevational view, the opposite end being a mirror image thereof; FIG. 3 is a front elevational view; FIG. 4 is a rear elevational view; FIG. 5 is a top plan view; FIG. 6 is a bottom plan view; FIG. 7 is a perspective view of a second embodiment of a glider showing our new design in the form of a single seating unit; FIG. 8 is an end elevational view; FIG. 9 is a front elevational view; FIG. 10 is a rear elevational view; FIG. 11 is a top plan view; and, FIG. 12 is a bottom plan view.

The broken line showing of the top slat of the gliders is for illustrative purposes only and forms no part of the claimed design.

1 Claim, 6 Drawing Sheets

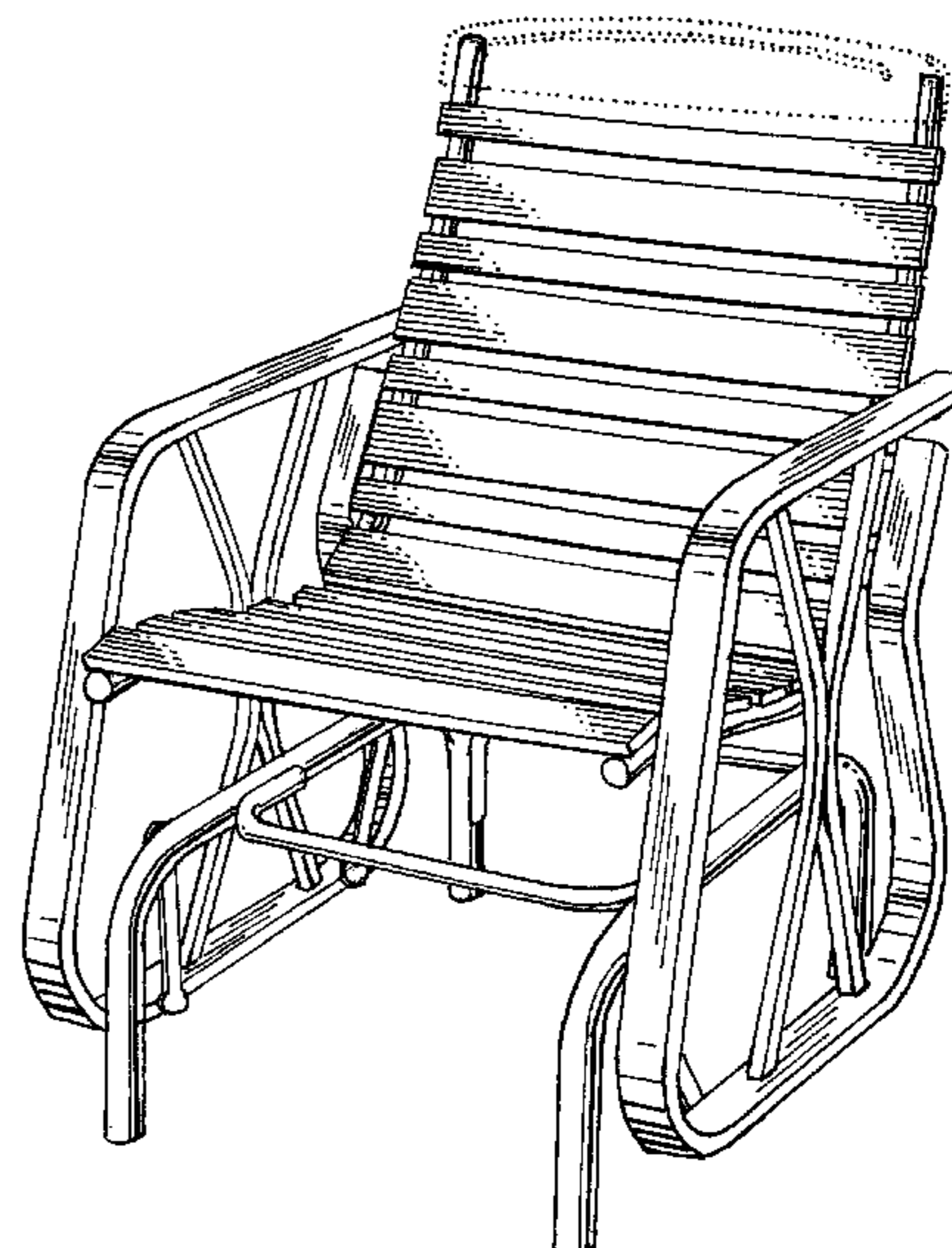
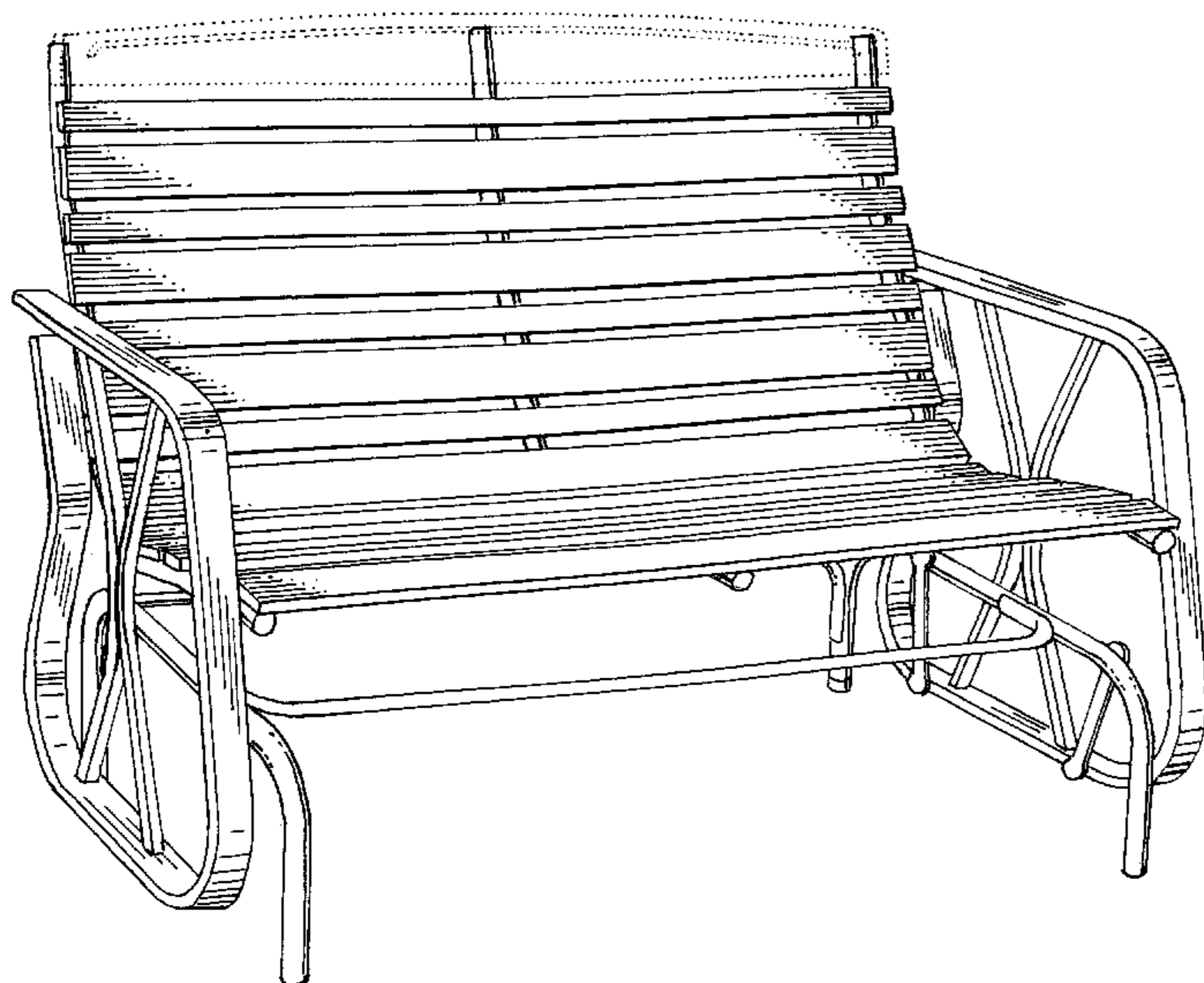

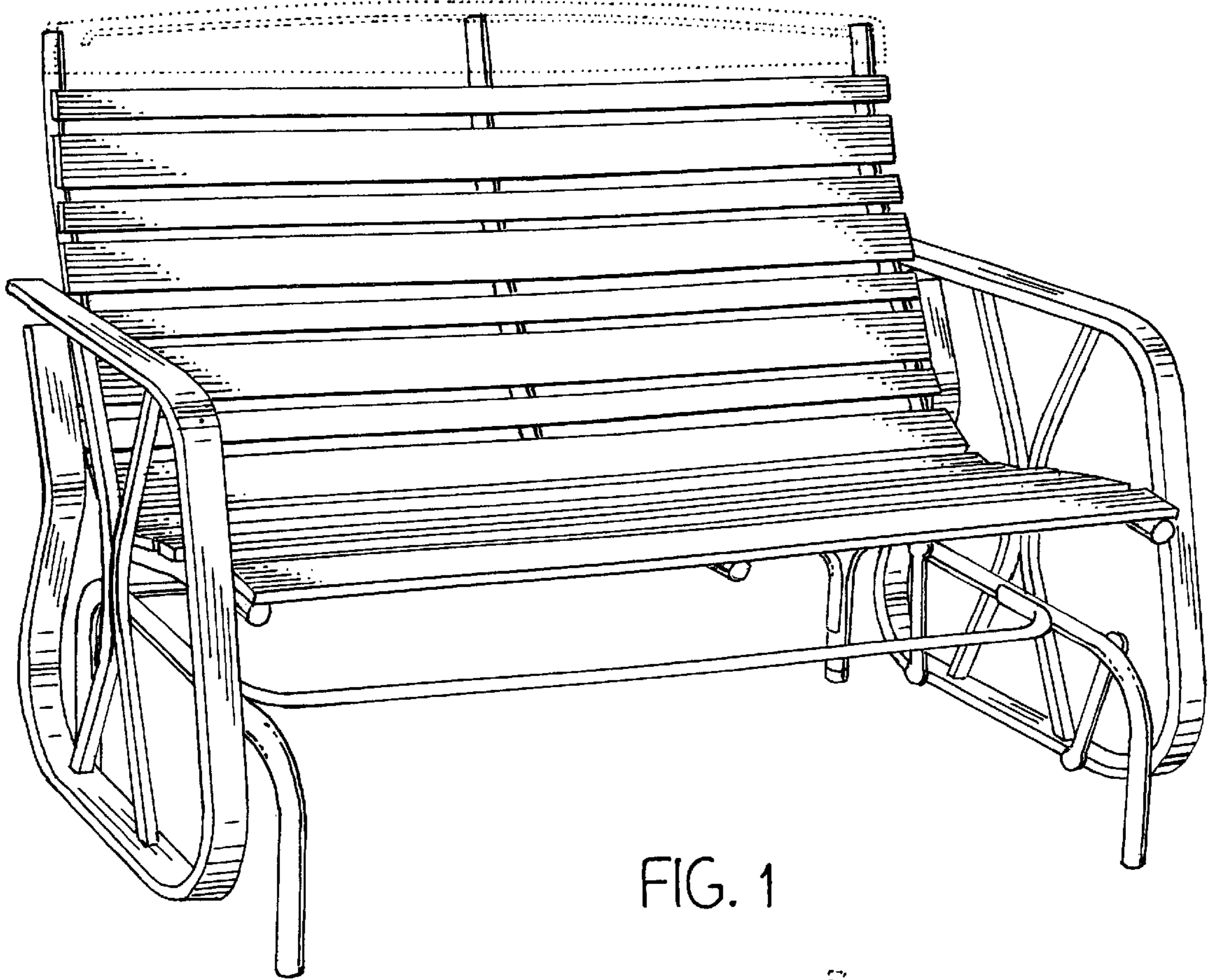

FIG. 1

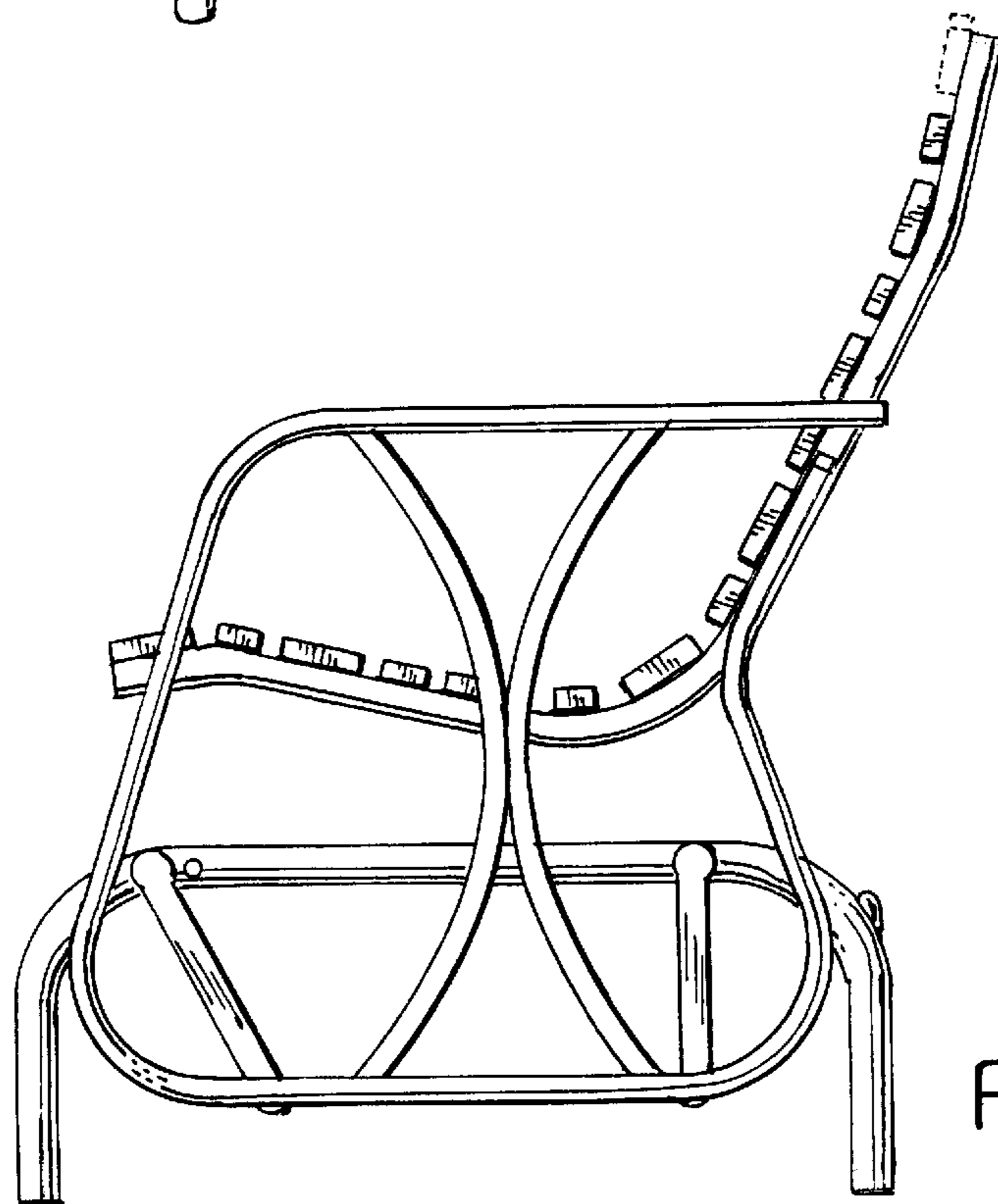

FIG. 2

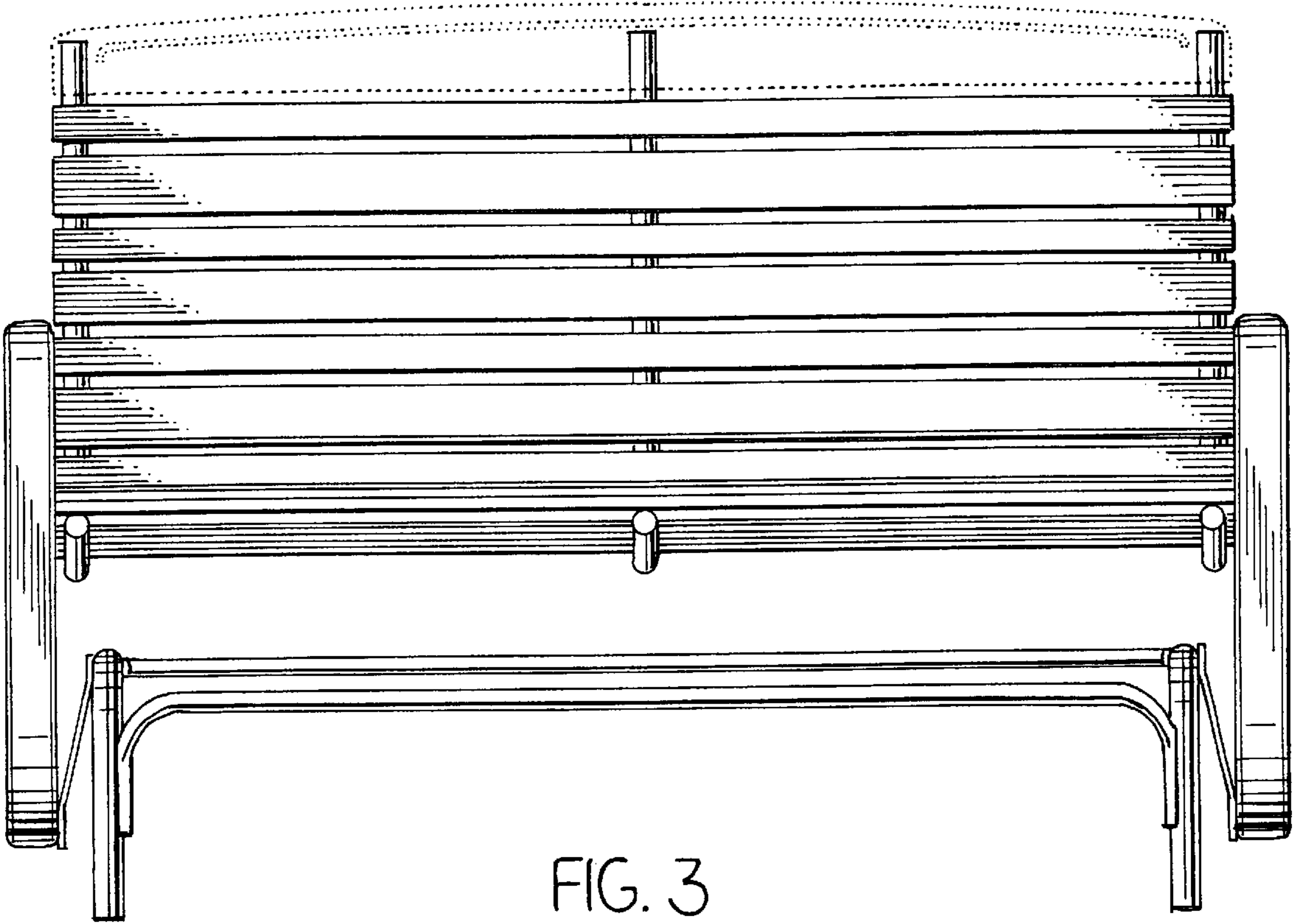

FIG. 3

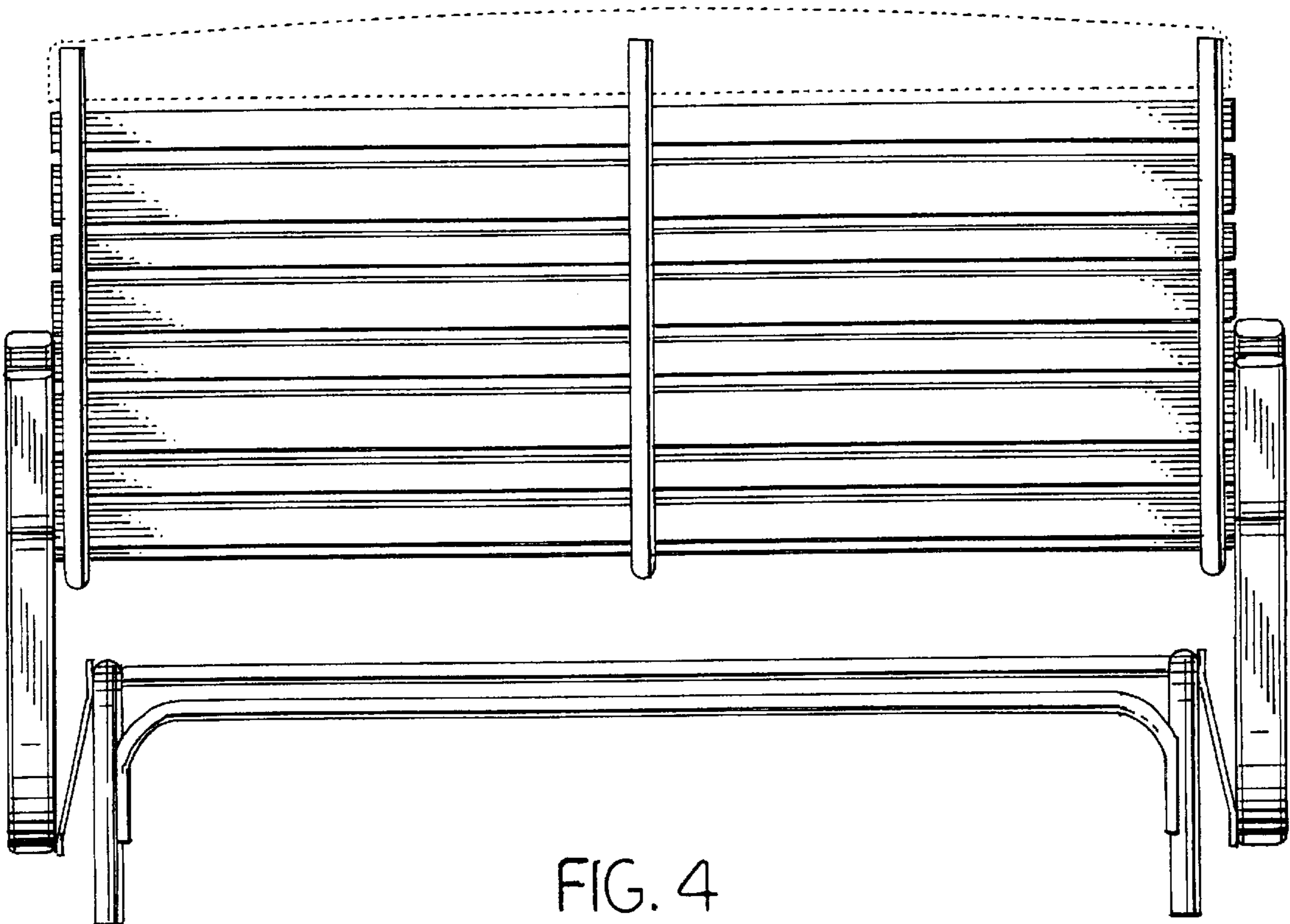

FIG. 4

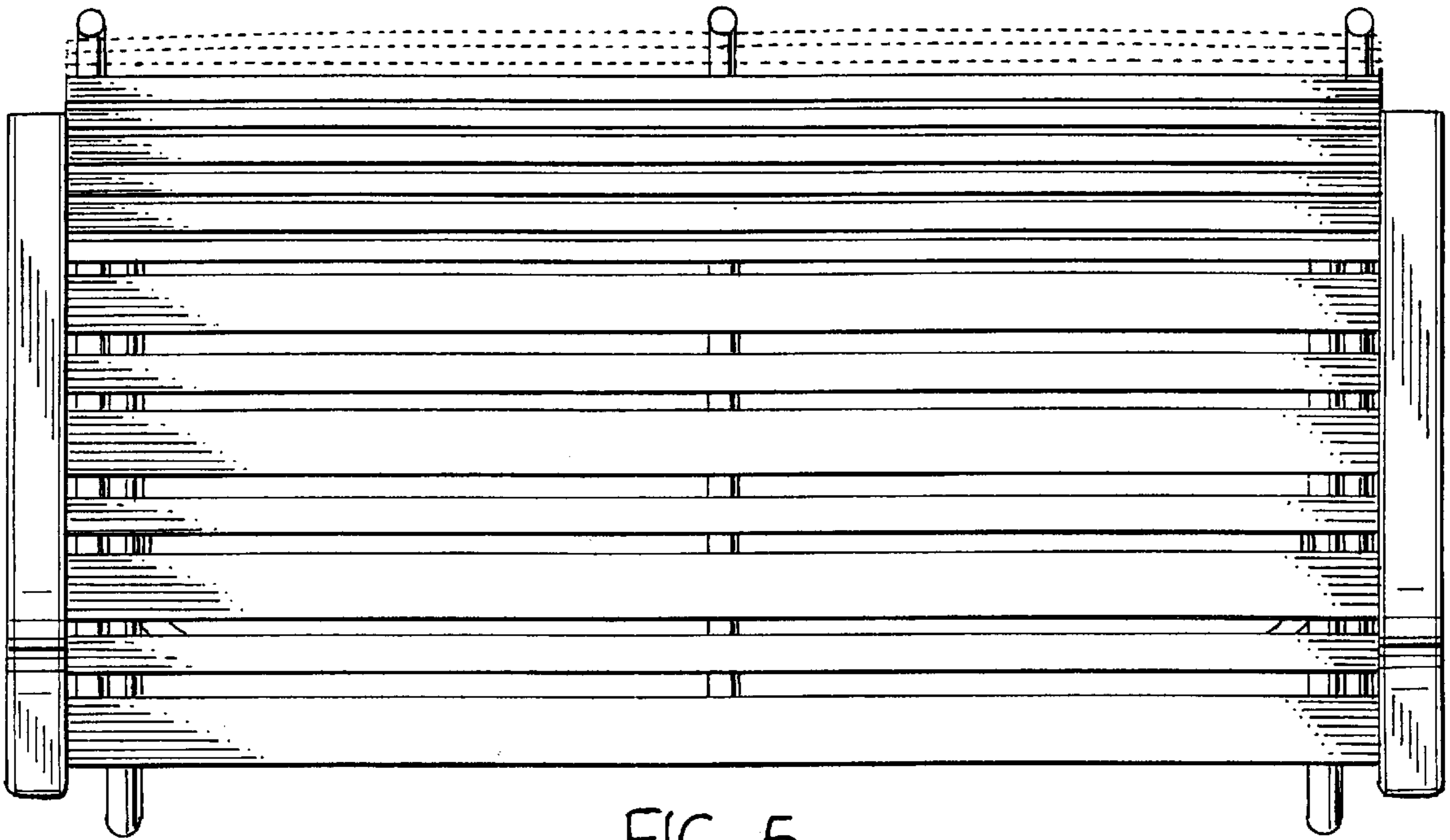

FIG. 5

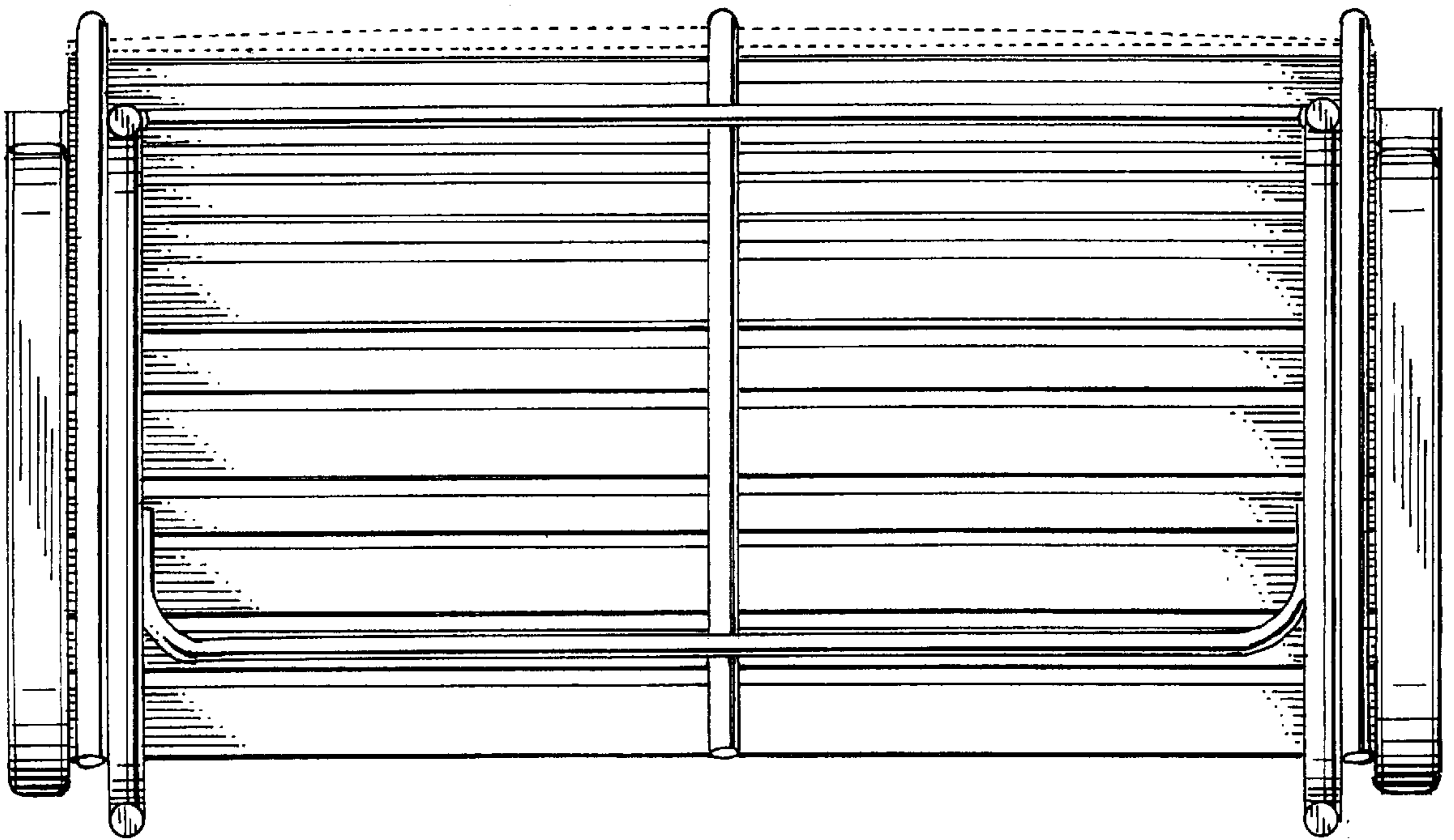

FIG. 6

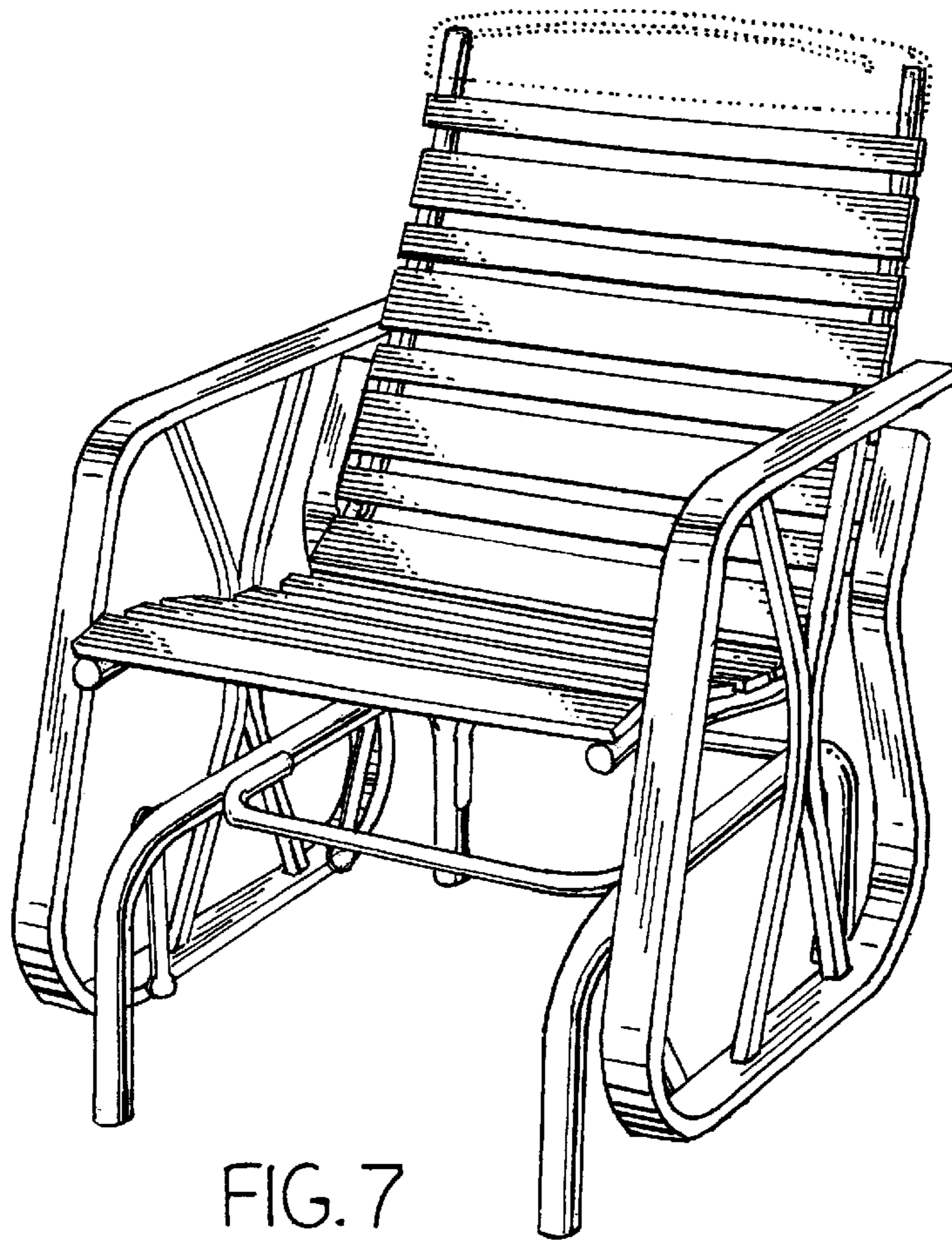

FIG. 7

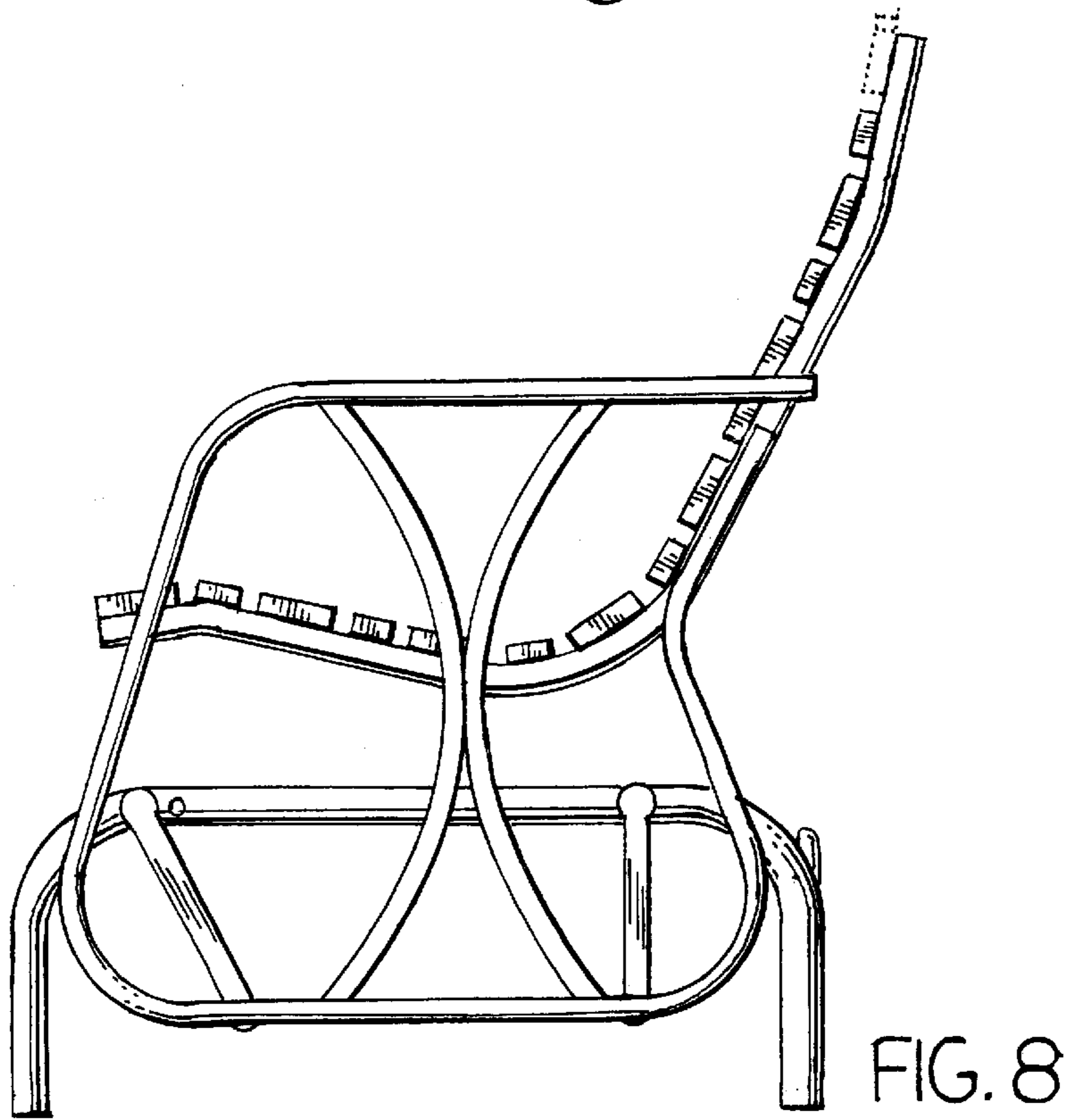

FIG. 8

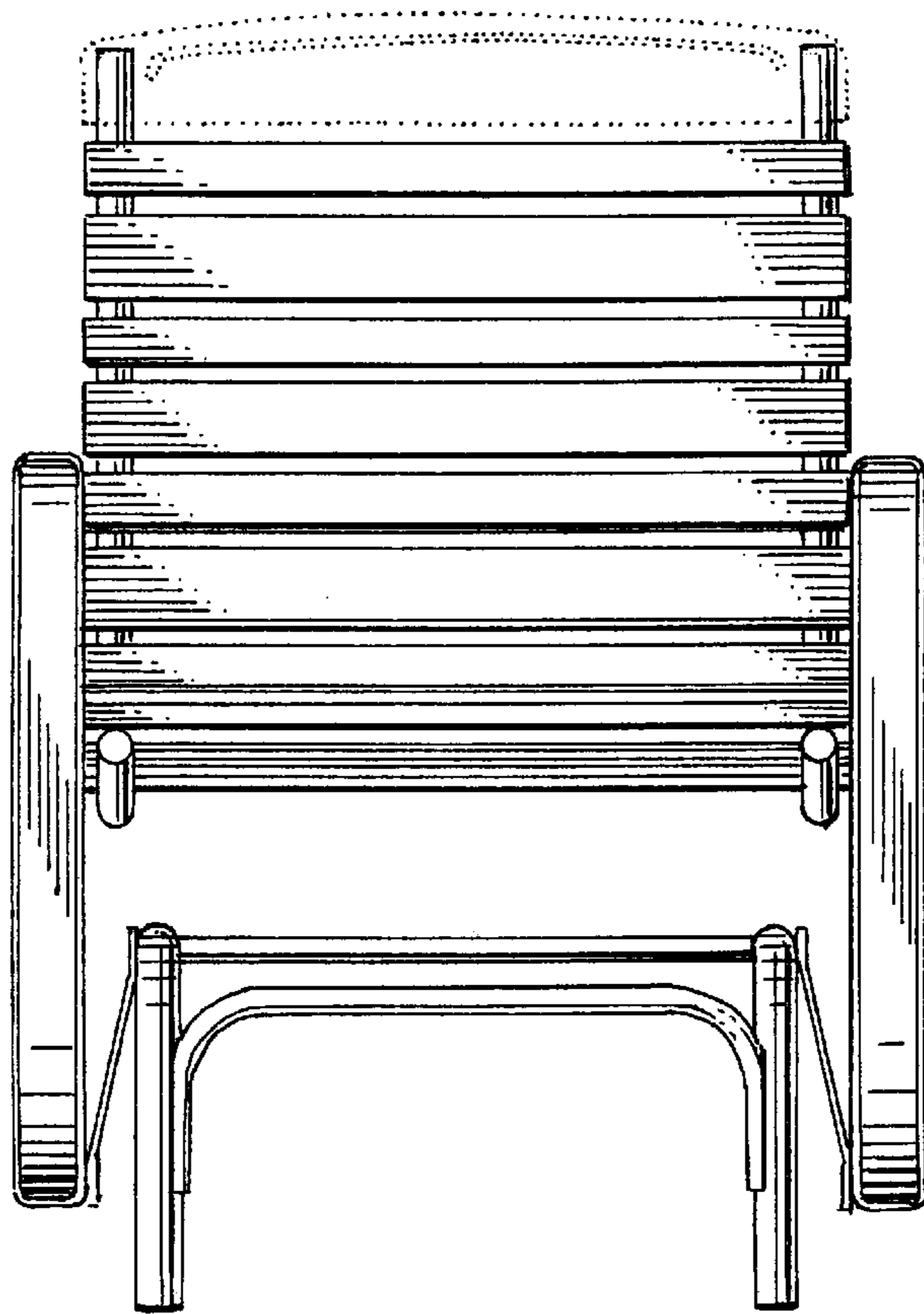

FIG. 9

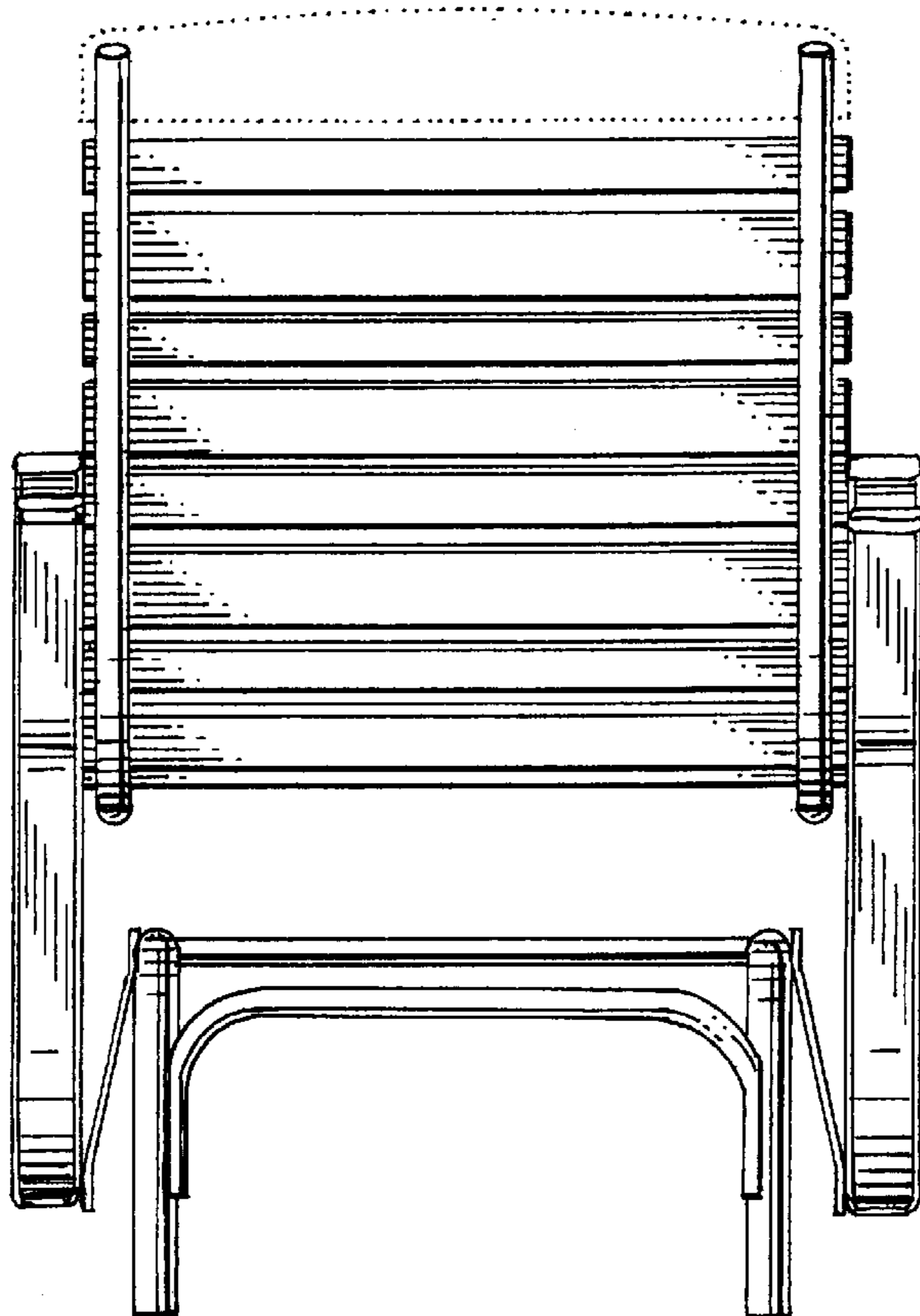

FIG. 10

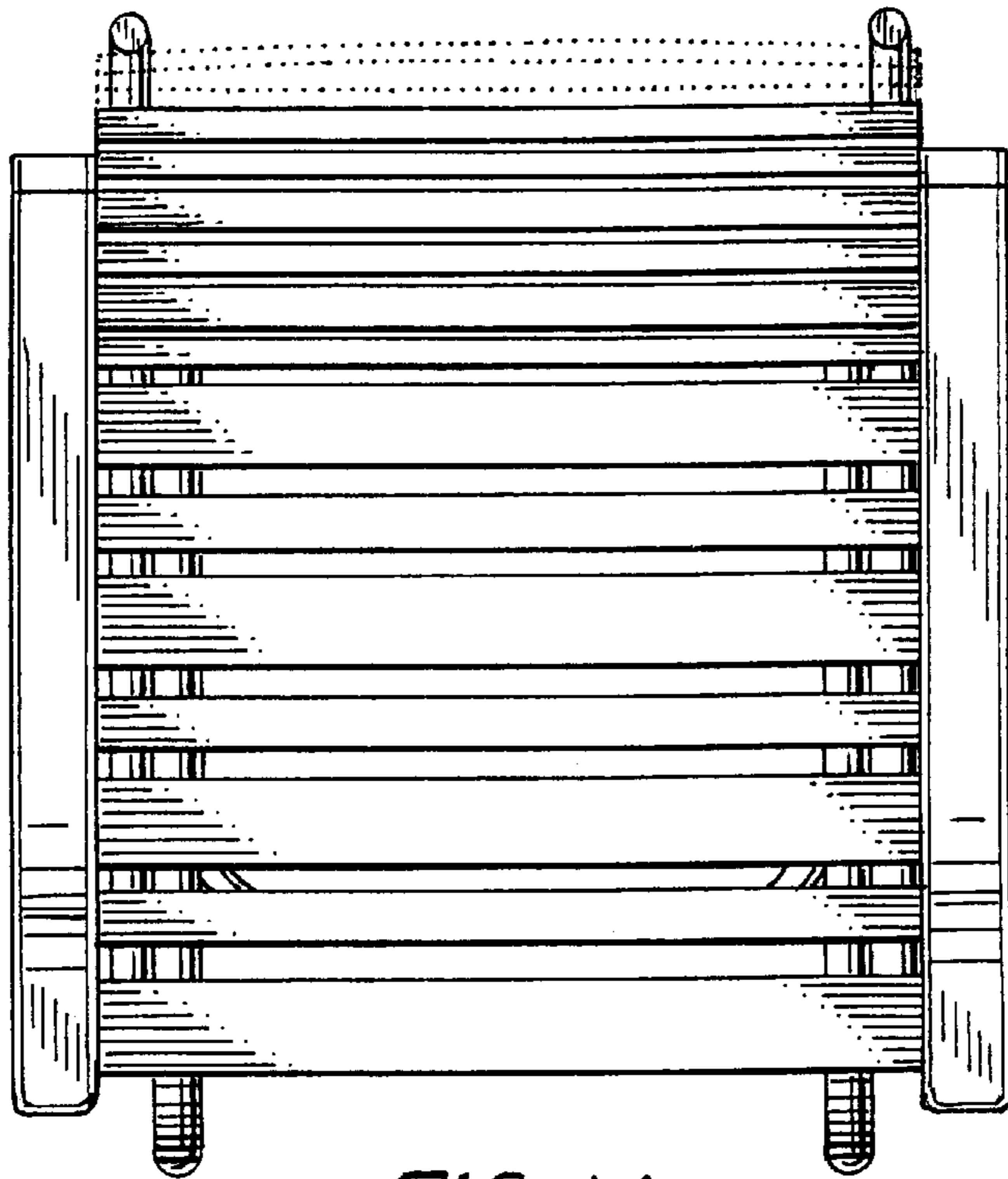

FIG. 11

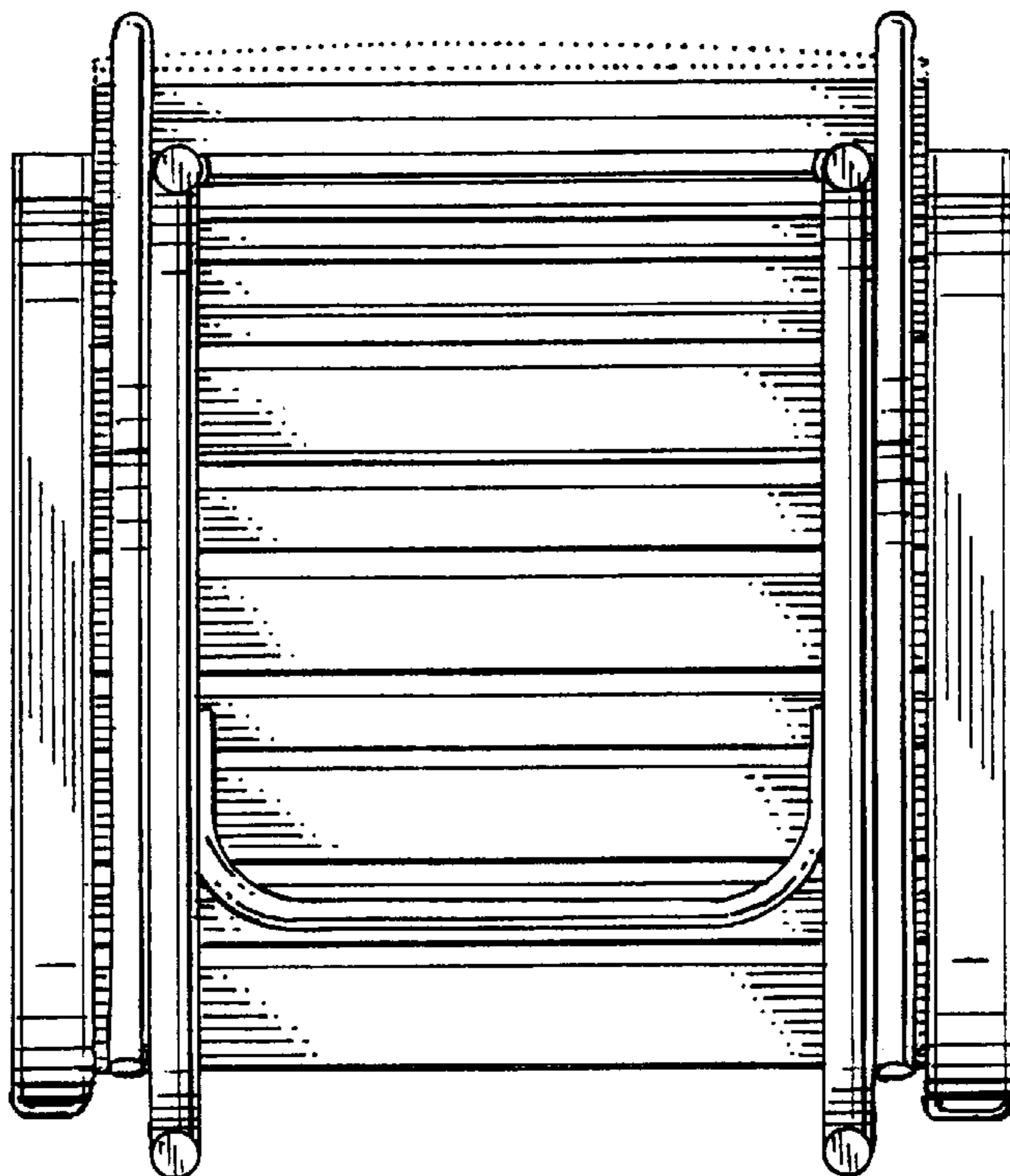

FIG. 12