



US00D432177S

United States Patent [19]
Wildrick

[11] **Patent Number: Des. 432,177**

[45] **Date of Patent: ** Oct. 17, 2000**

[54] **LABEL HOLDING STRIP**

D. 398,029 9/1998 Falls et al. D20/44

[75] Inventor: **Richard J. Wildrick**, Hunlock Creek, Pa.

Primary Examiner—Marcus A. Jackson
Attorney, Agent, or Firm—Schweitzer Cornman Gross & Bondell LLP

[73] Assignee: **Trion Industries, Inc.**, Wilkes-Barre, Pa.

[**] Term: **14 Years**

[57] **CLAIM**

[21] Appl. No.: **29/120,820**

The ornamental design for a label holding strip, as shown and described.

[22] Filed: **Mar. 27, 2000**

DESCRIPTION

[51] **LOC (7) Cl.** **19-08**

[52] **U.S. Cl.** **D20/44**

[58] **Field of Search** D20/10, 42, 43, D20/44; D25/119, 121, 122, 124; 40/584, 124.01, 649, 653, 654.01, 661; 52/522; 361/680, 681

FIG. 1 is a front perspective view of the label holding strip of the invention, shown broken at the right side to indicate indeterminate length; and,

FIG. 2 is a rear perspective view thereof, broken at the left side to indicate indeterminate length.

[56] **References Cited**

U.S. PATENT DOCUMENTS

D. 338,689 8/1993 Rosenthal D20/43

1 Claim, 2 Drawing Sheets

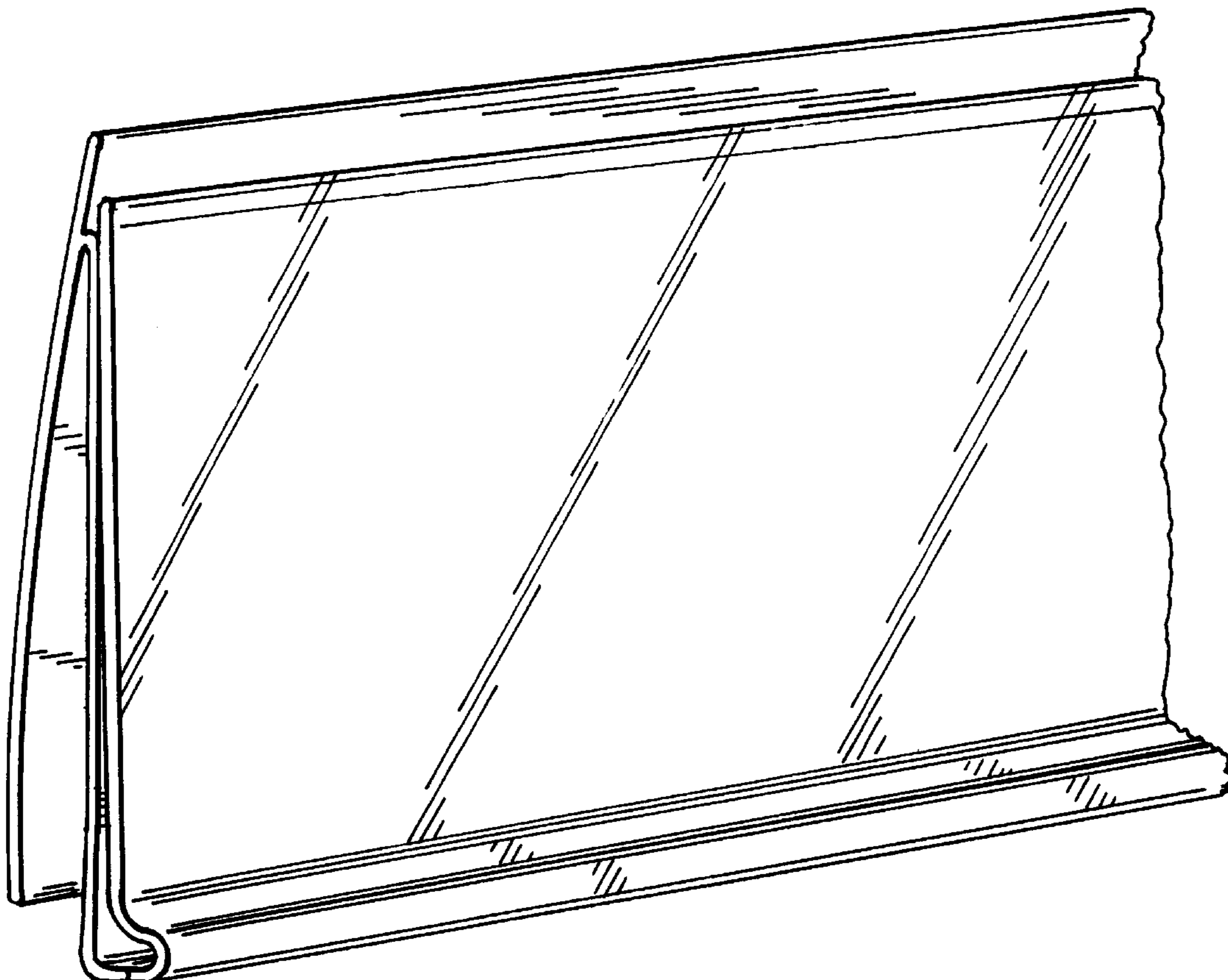

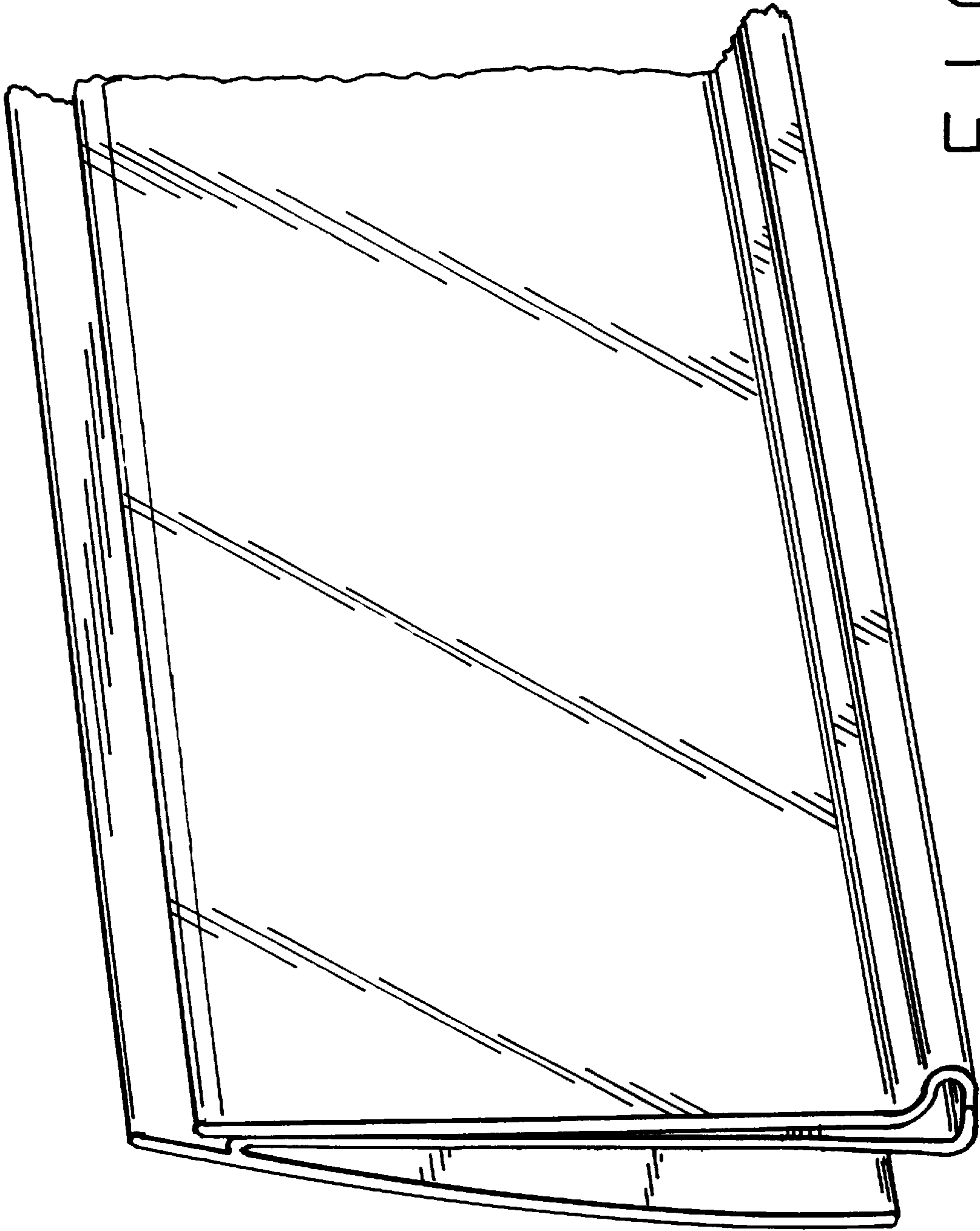

FIG. 1

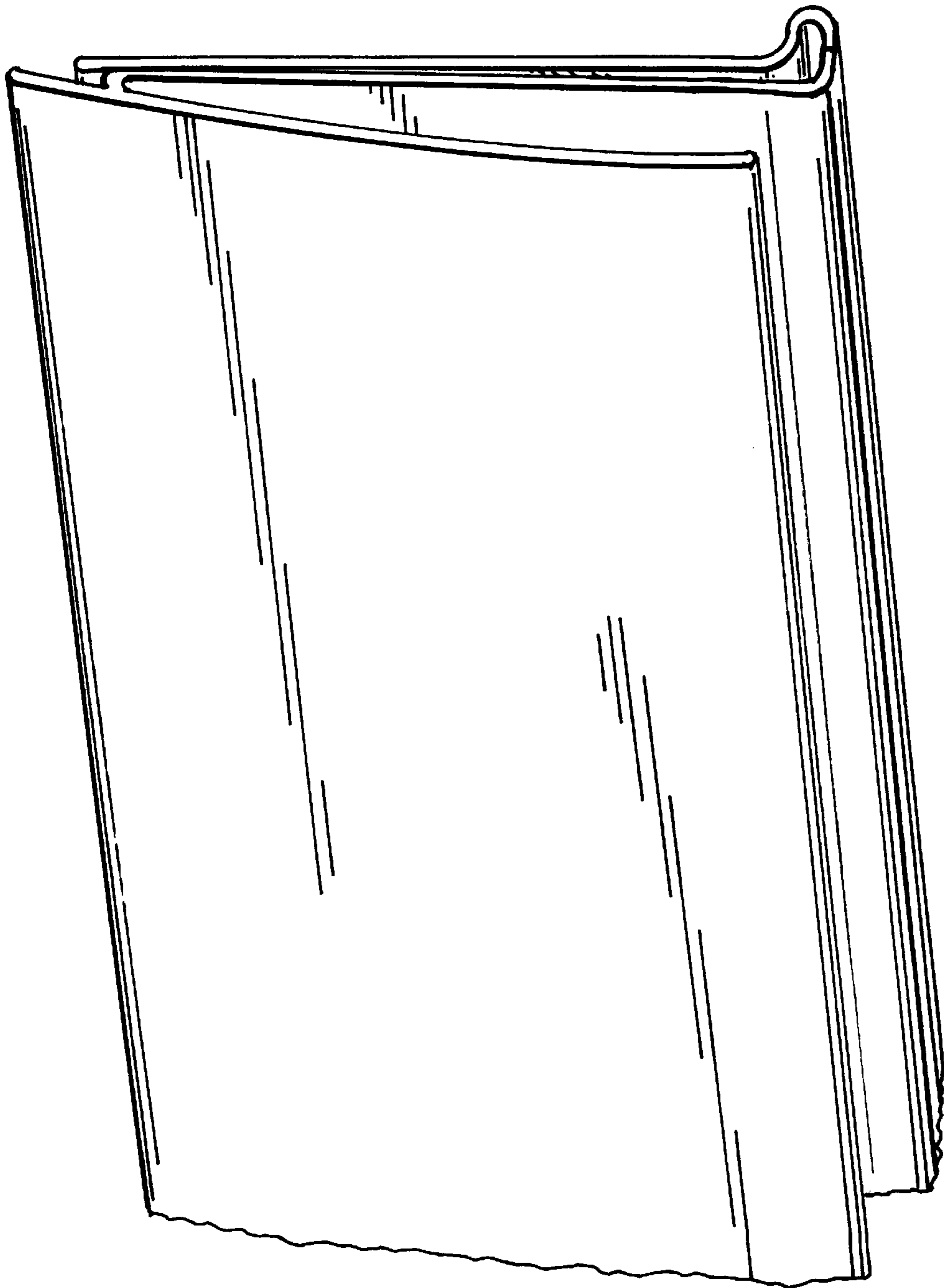

FIG. 2