



US00D432095S

United States Patent [19]

[11] Patent Number: Des. 432,095

Seeger et al.

[45] Date of Patent: ** Oct. 17, 2000

[54] LIGHT-EMITTING SEMI-CONDUCTOR COMPONENT

[75] Inventors: Reinhold Seeger, Eppingen; Jürgen Riedel, Gemmingen, both of Germany

[73] Assignee: Vishay Semiconductor GmbH, Heilbronn, Germany

[**] Term: 14 Years

[21] Appl. No.: 29/102,994

[22] Filed: Apr. 6, 1999

[30] Foreign Application Priority Data

Oct. 9, 1998 [DE] Germany 4 98 10 368

[51] LOC (7) Cl. 13-03

[52] U.S. Cl. D13/182

[58] Field of Search D13/182; 362/800; D26/2; D10/111, 114

[56] References Cited

U.S. PATENT DOCUMENTS

5,746,500	5/1998	Chien	362/800	X
5,924,785	7/1999	Zhang et al.	362/800	X
5,984,488	11/1999	Tung	362/800	X
6,061,160	5/2000	Maruyama	362/800	X
6,069,447	5/2000	Vilanelam	362/800	X

OTHER PUBLICATIONS

“Super Flux LEDs; Technical Data,” Hewlett Packard, Apr., 1996, pp. 1–25—1–26.

Primary Examiner—Brian N. Vinson

Attorney, Agent, or Firm—Evenson, McKeown, Edwards & Lenahan, P.L.L.C.

[57] CLAIM

The ornamental design for a light-emitting semi-conductor component, as shown and described.

DESCRIPTION

FIG. 1 is a perspective right side view of a light-emitting semi-conductor component according to our novel design; FIG. 2 is a top view of the light-emitting semi-conductor component according to our novel design; FIG. 3 is a bottom view of the light-emitting semi-conductor component according to our novel design; FIG. 4 is a right side view of the light-emitting semi-conductor component according to our novel design;

FIG. 5 is a left side view of the light-emitting semi-conductor component according to our novel design; FIG. 6 is a front view of the light-emitting semi-conductor component according to our novel design; FIG. 7 is a back view of the light-emitting semi-conductor component according to our novel design; FIG. 8 is another perspective right side view of the light-emitting semi-conductor component according to our novel design, depicting an alternative environment; FIG. 9 is another top view of the light-emitting semi-conductor component according to our novel design, depicting an alternative environment; FIG. 10 is another bottom view of the light-emitting semi-conductor component according to our novel design, depicting an alternative environment; FIG. 11 is another right side view of the light-emitting semi-conductor component according to our novel design, depicting an alternative environment; FIG. 12 is another left side view of the light-emitting semi-conductor component according to our novel design, depicting an alternative environment; FIG. 13 is another front view of the light-emitting semi-conductor component according to our novel design, depicting an alternative environment; FIG. 14 is another back view of the light-emitting semi-conductor component according to our novel design, depicting an alternative environment; FIG. 15 is another perspective right side view of the light-emitting semi-conductor component according to our novel design, depicting an alternative environment; FIG. 16 is another top view of the light-emitting semi-conductor component according to our novel design, depicting an alternative environment; FIG. 17 is another bottom view of the light-emitting semi-conductor component according to our novel design, depicting an alternative environment; FIG. 18 is another right side view of the light-emitting semi-conductor component according to our novel design, depicting an alternative environment; FIG. 19 is another left side view of the light-emitting semi-conductor component according to our novel design, depicting an alternative environment; FIG. 20 is another front view of the light-emitting semi-conductor component according to our novel design, depicting an alternative environment; and, FIG. 21 is another back view of the light-emitting semi-conductor component according to our novel design, depicting an alternative environment.

The dash lines included depict environment and are not part of the claimed design.

1 Claim, 9 Drawing Sheets

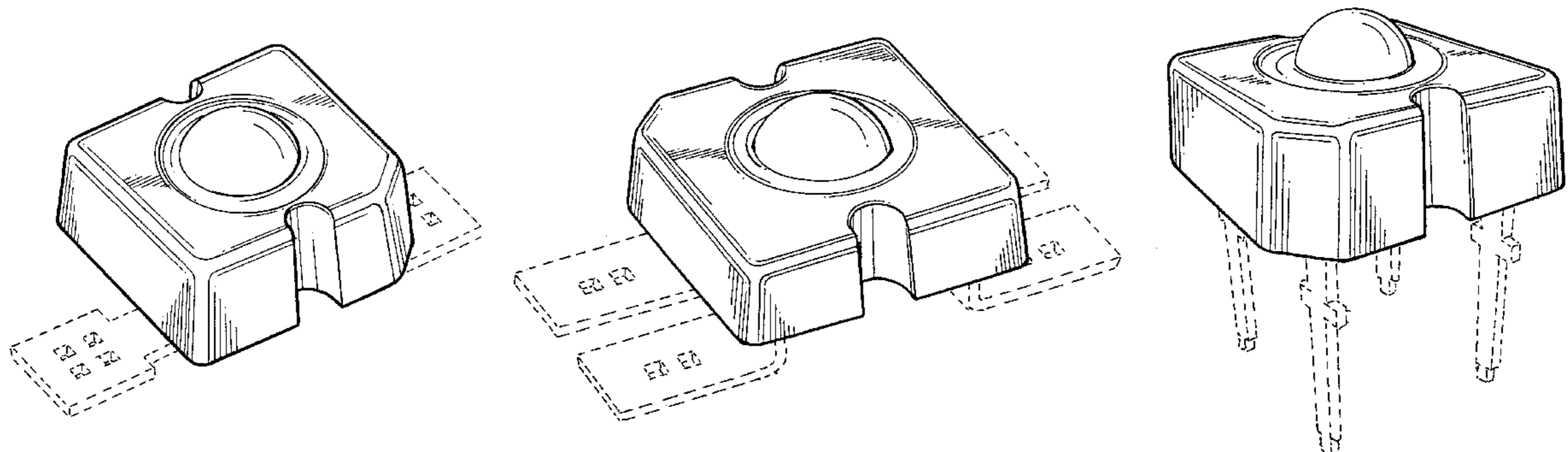

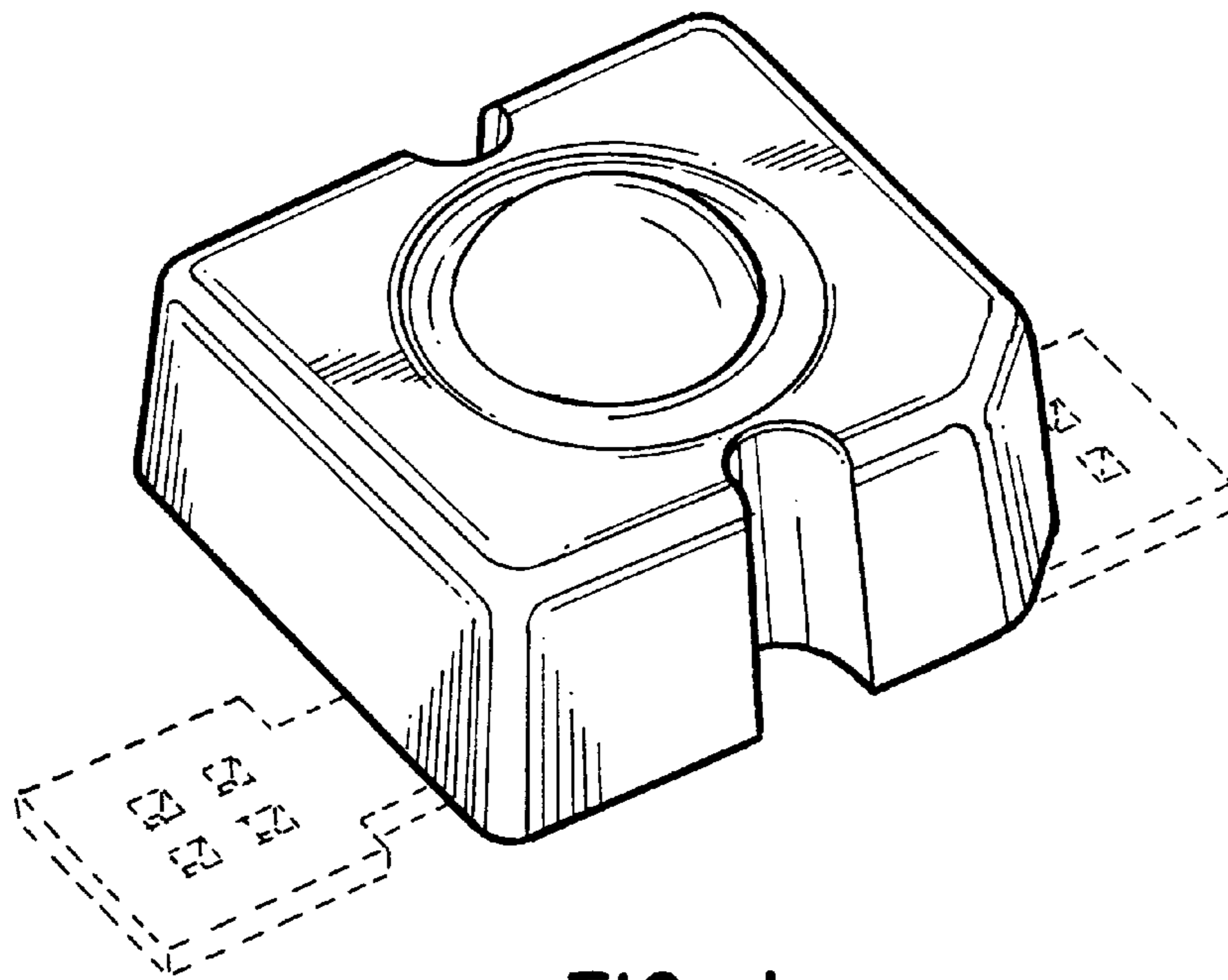

FIG. 1

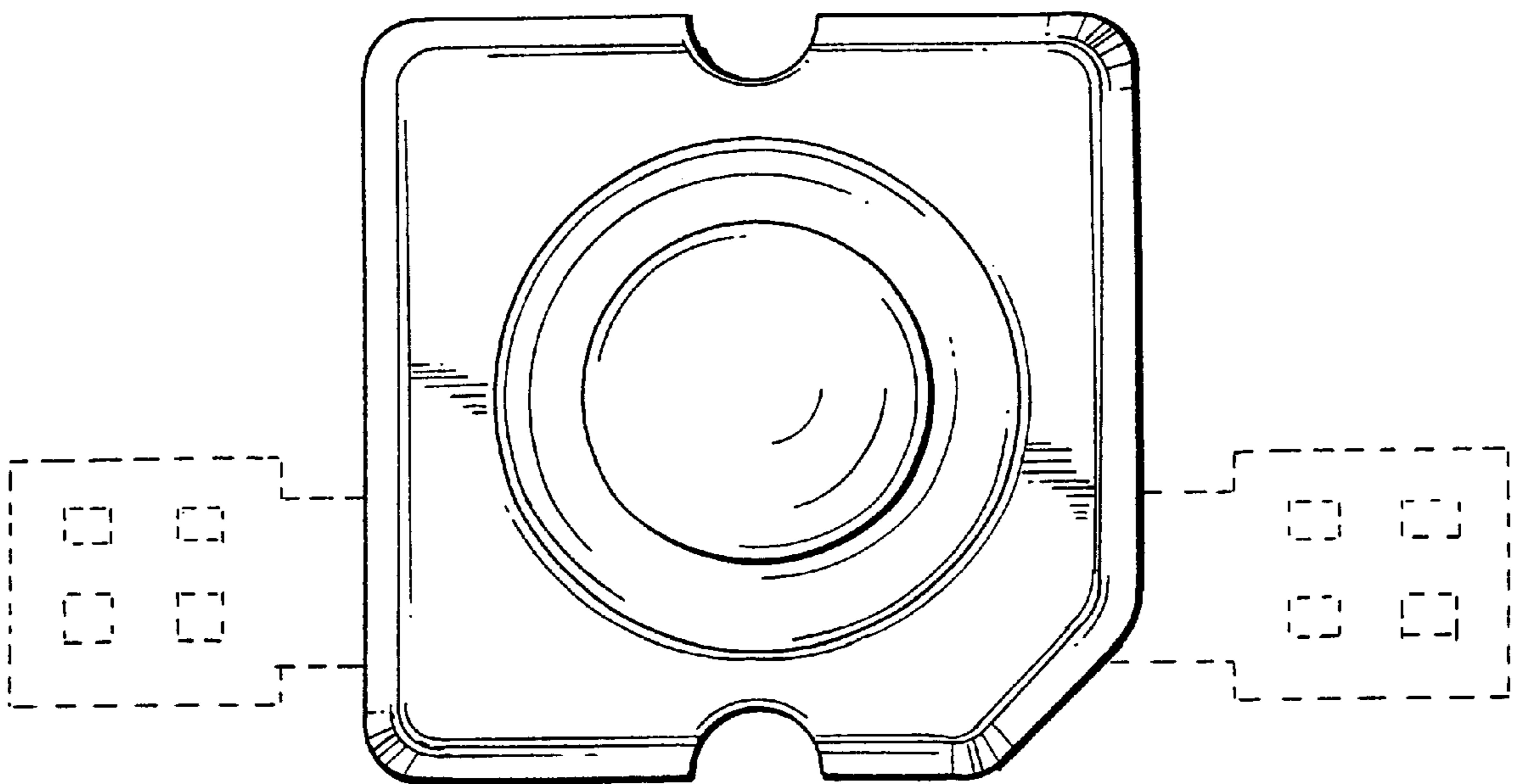

FIG. 2

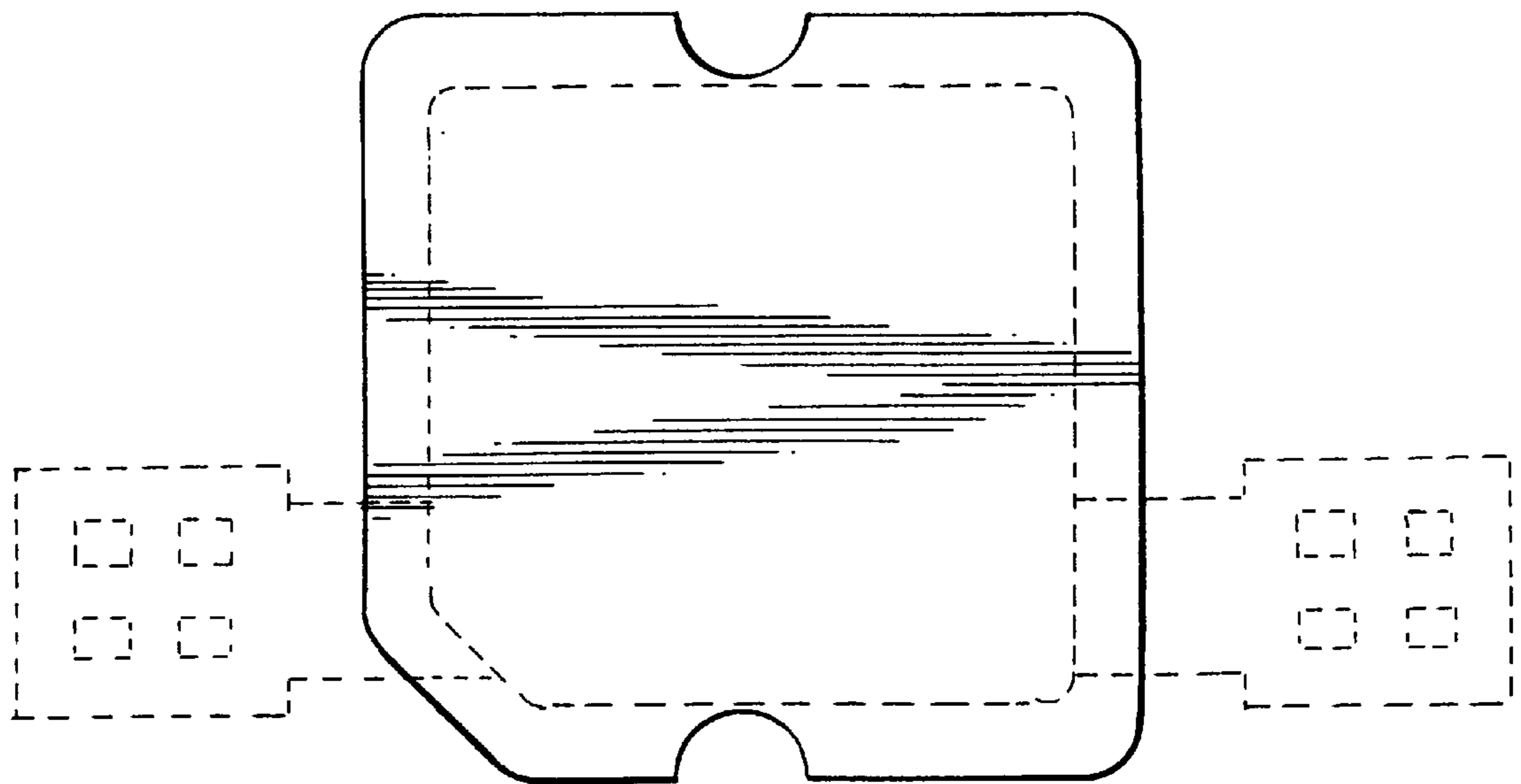

FIG. 3

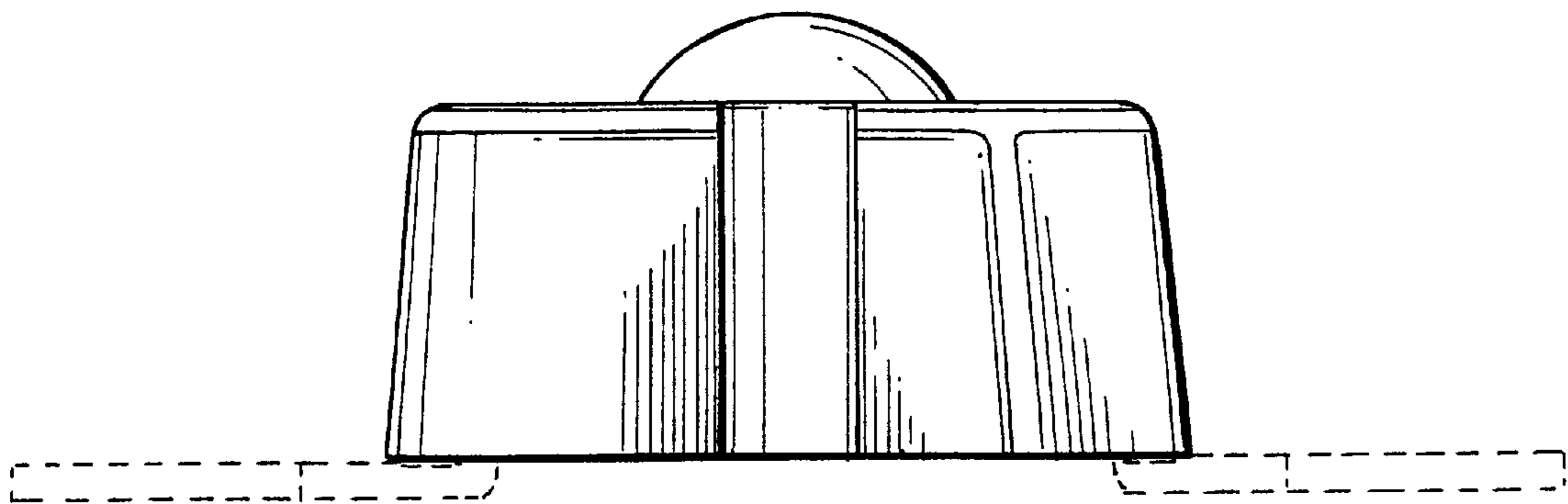

FIG. 4

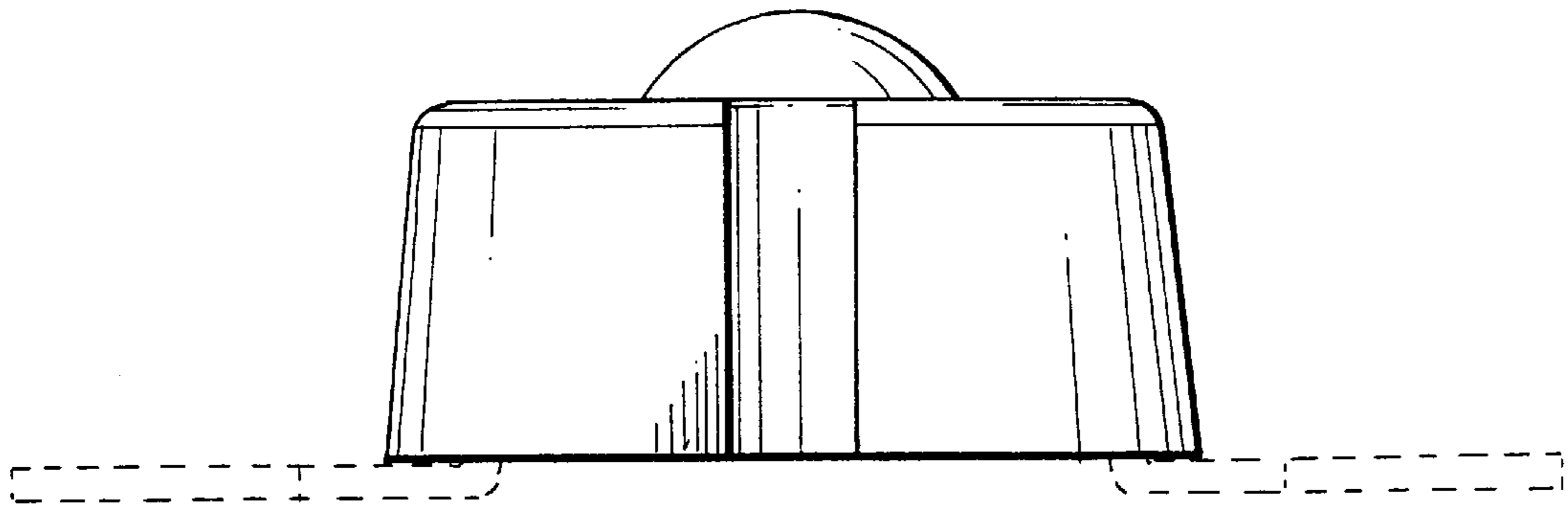

FIG. 5

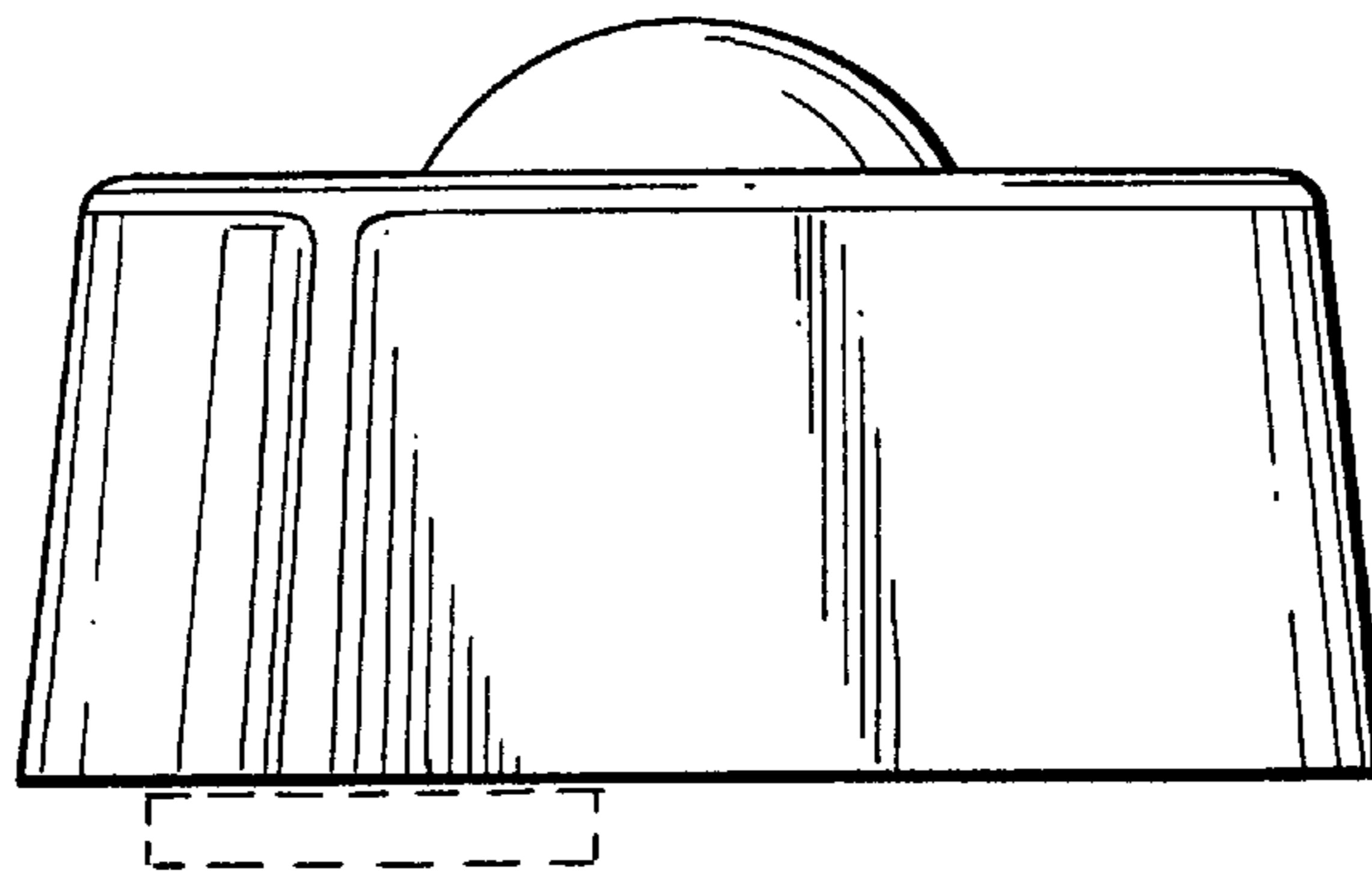

FIG. 6

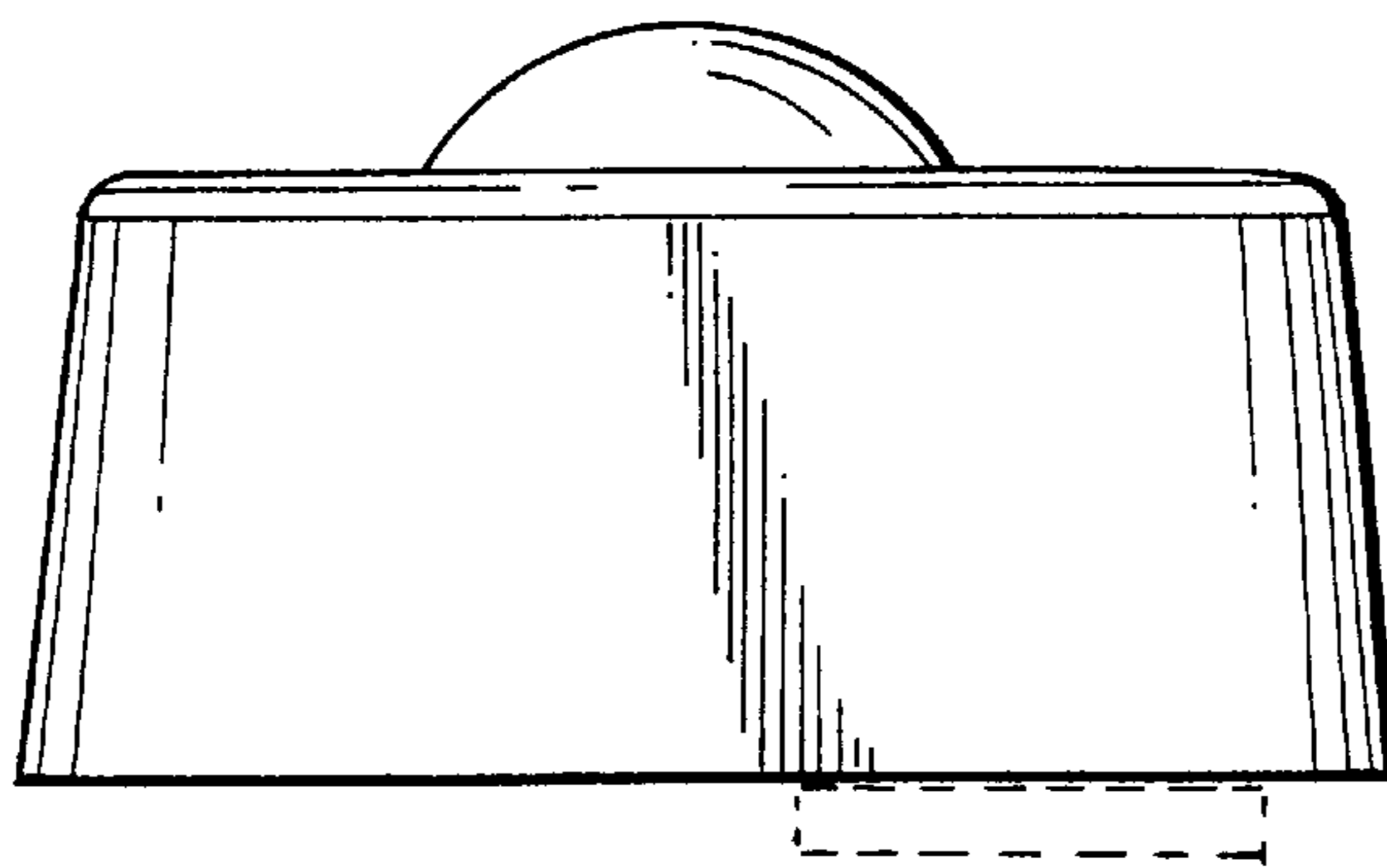

FIG. 7

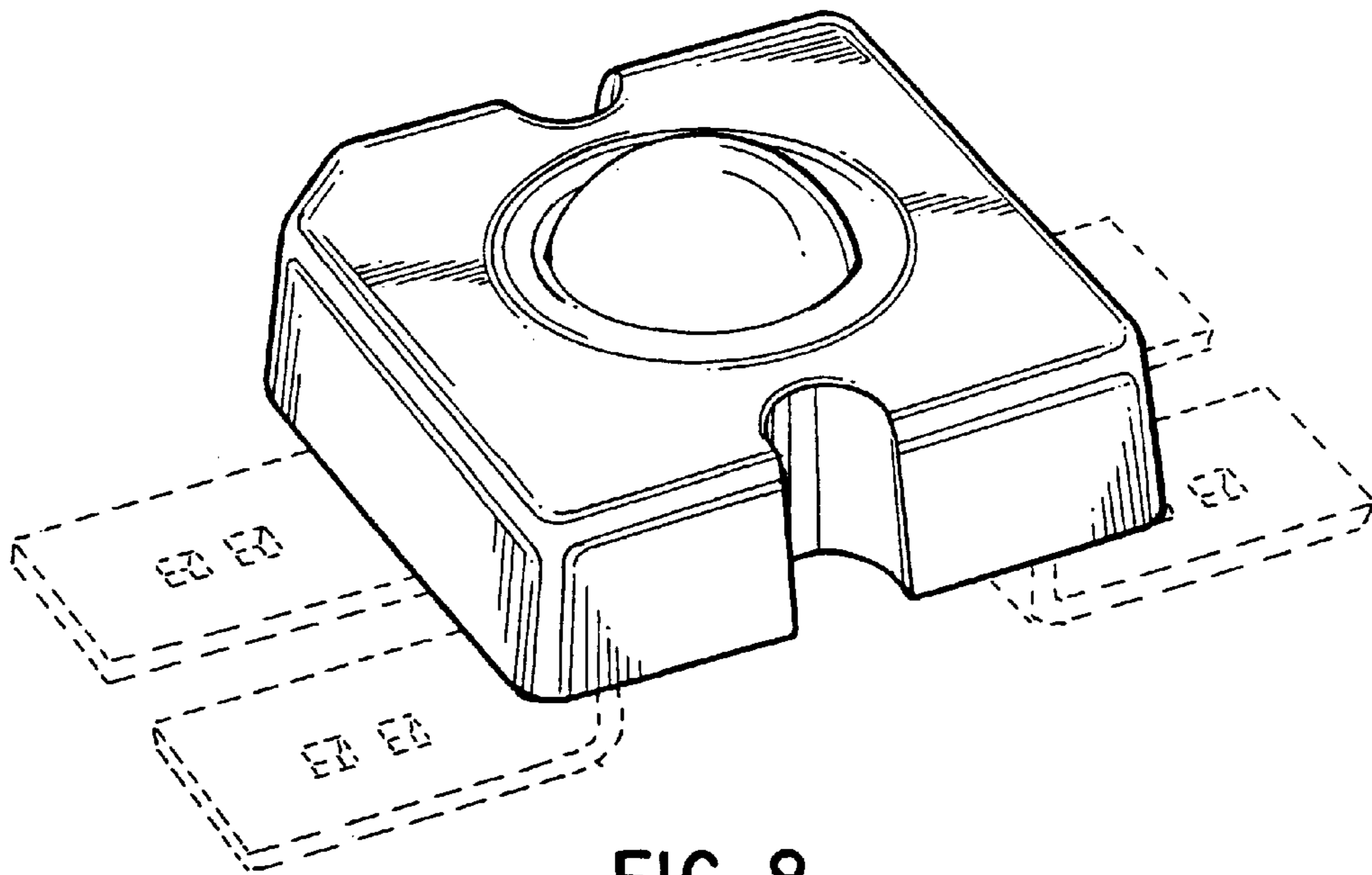

FIG. 8

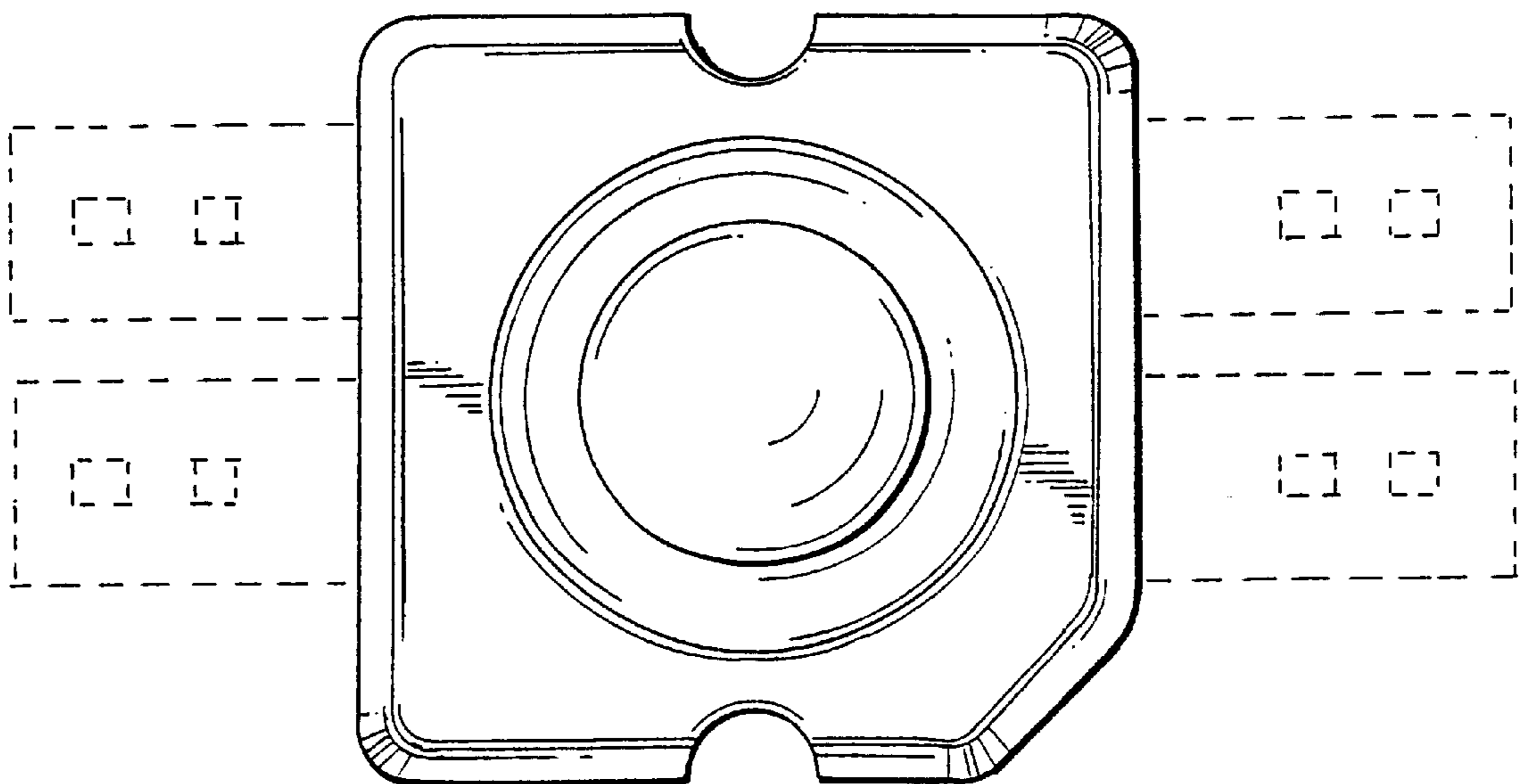

FIG. 9

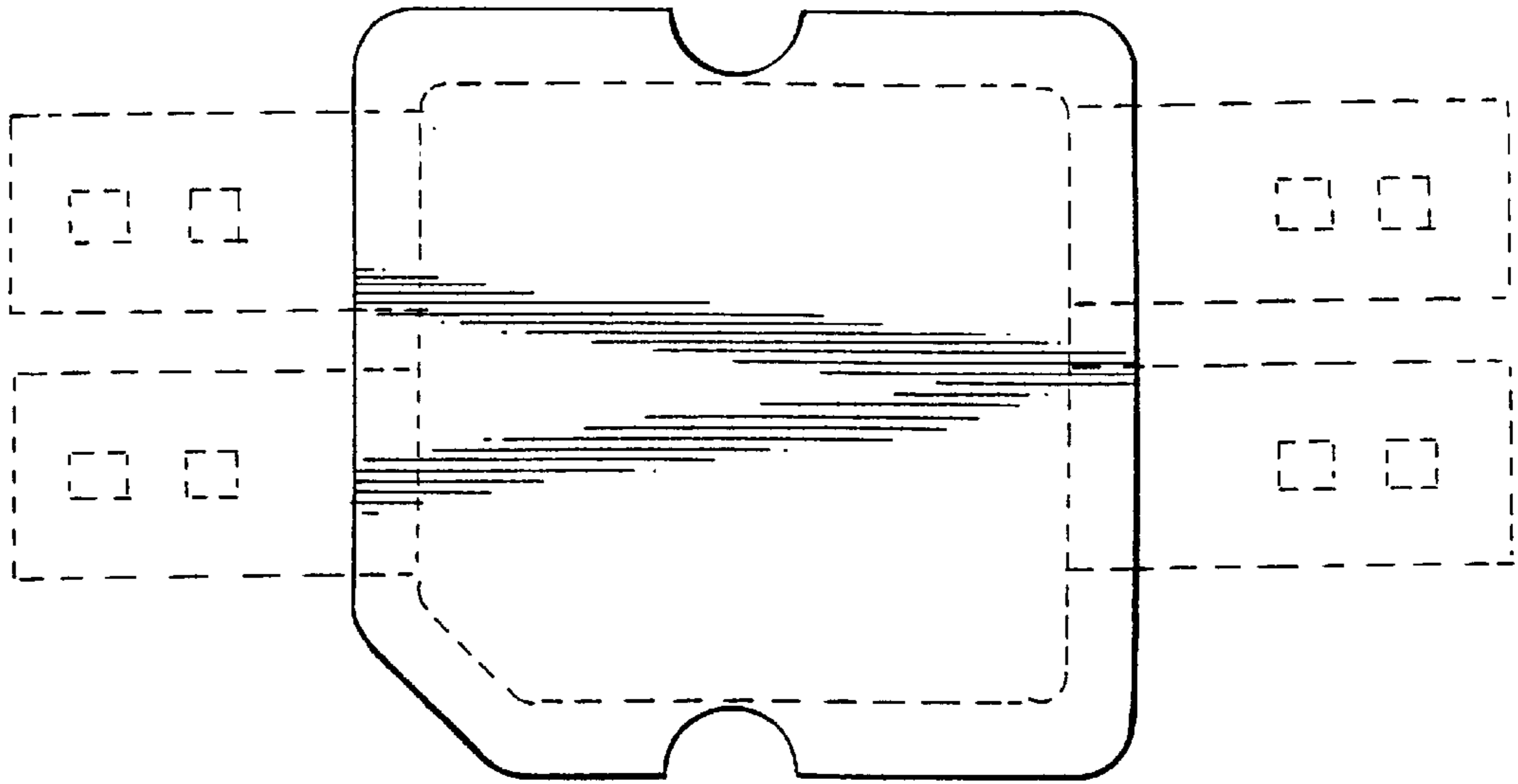

FIG. 10

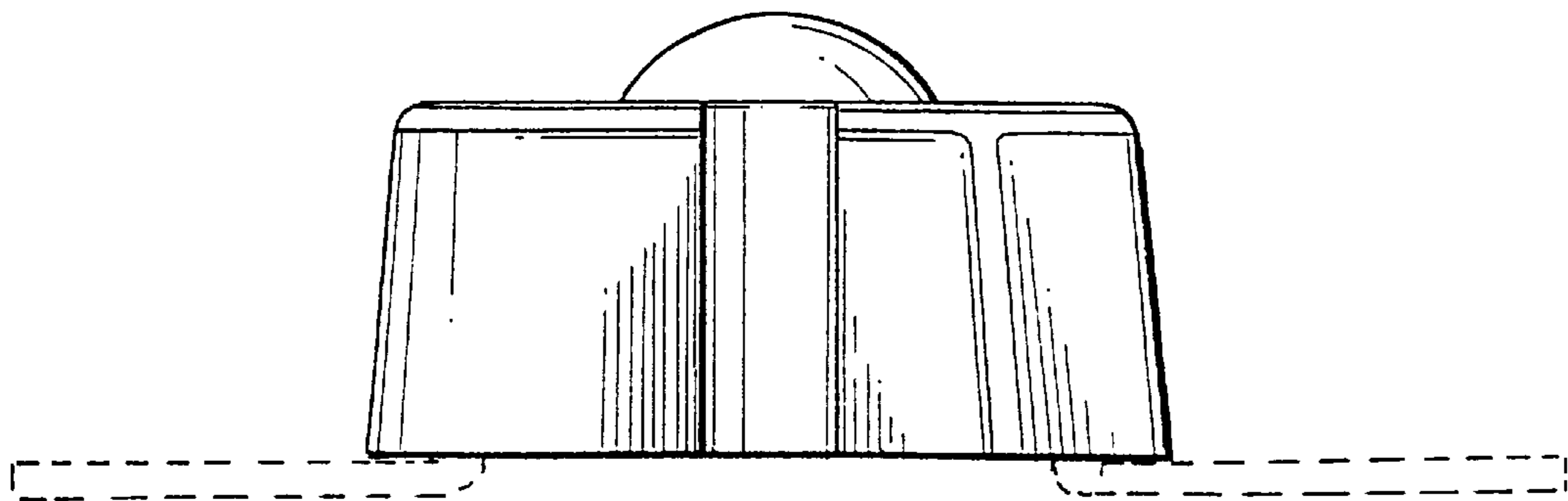

FIG. 11

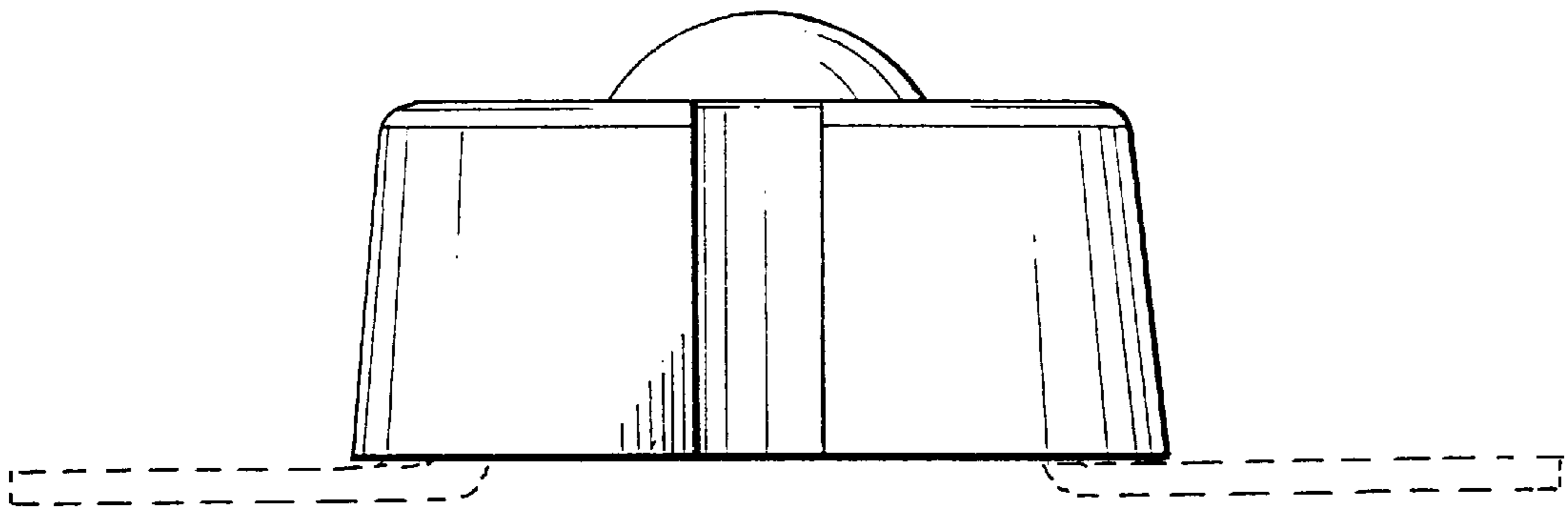

FIG. 12

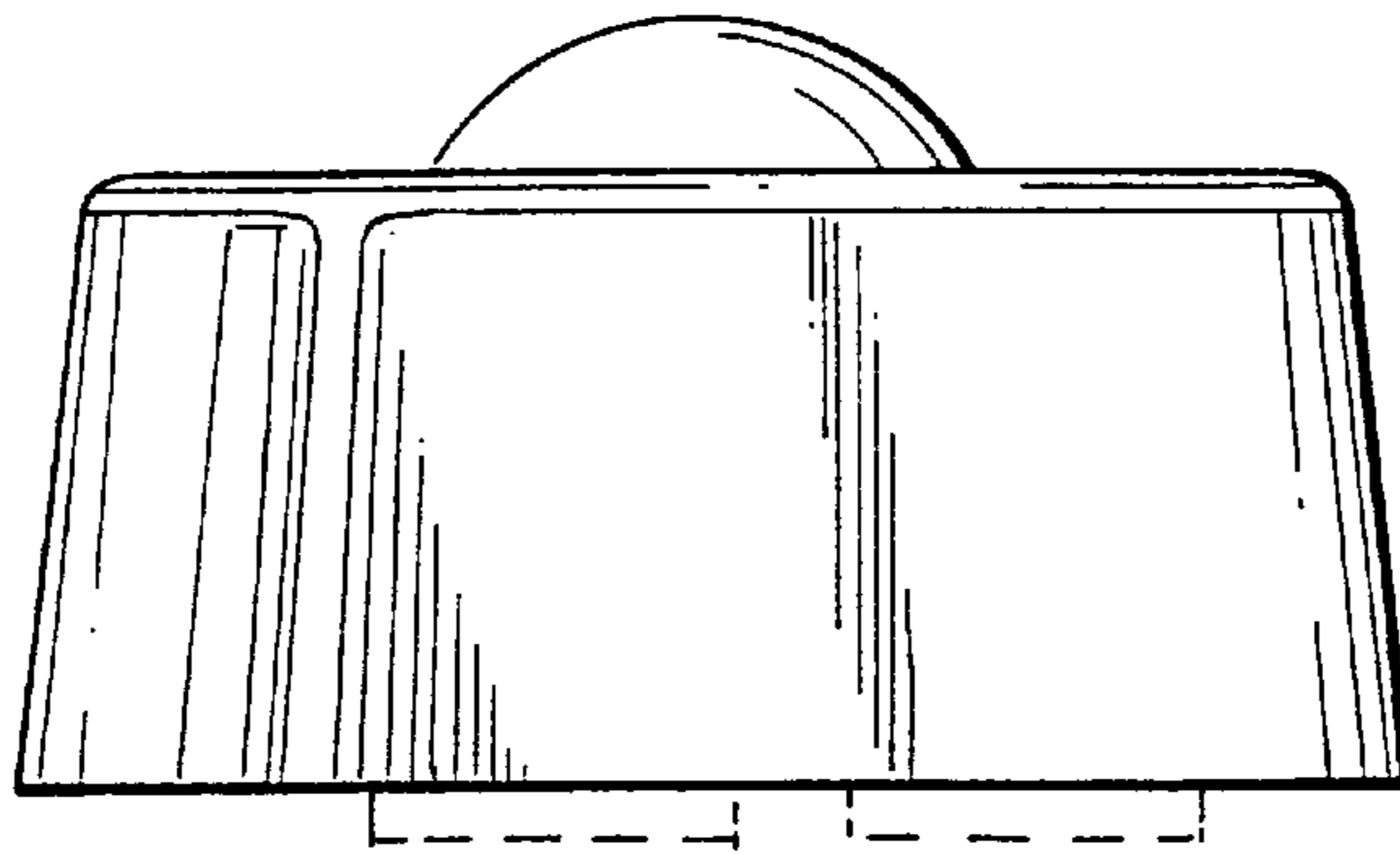

FIG. 13

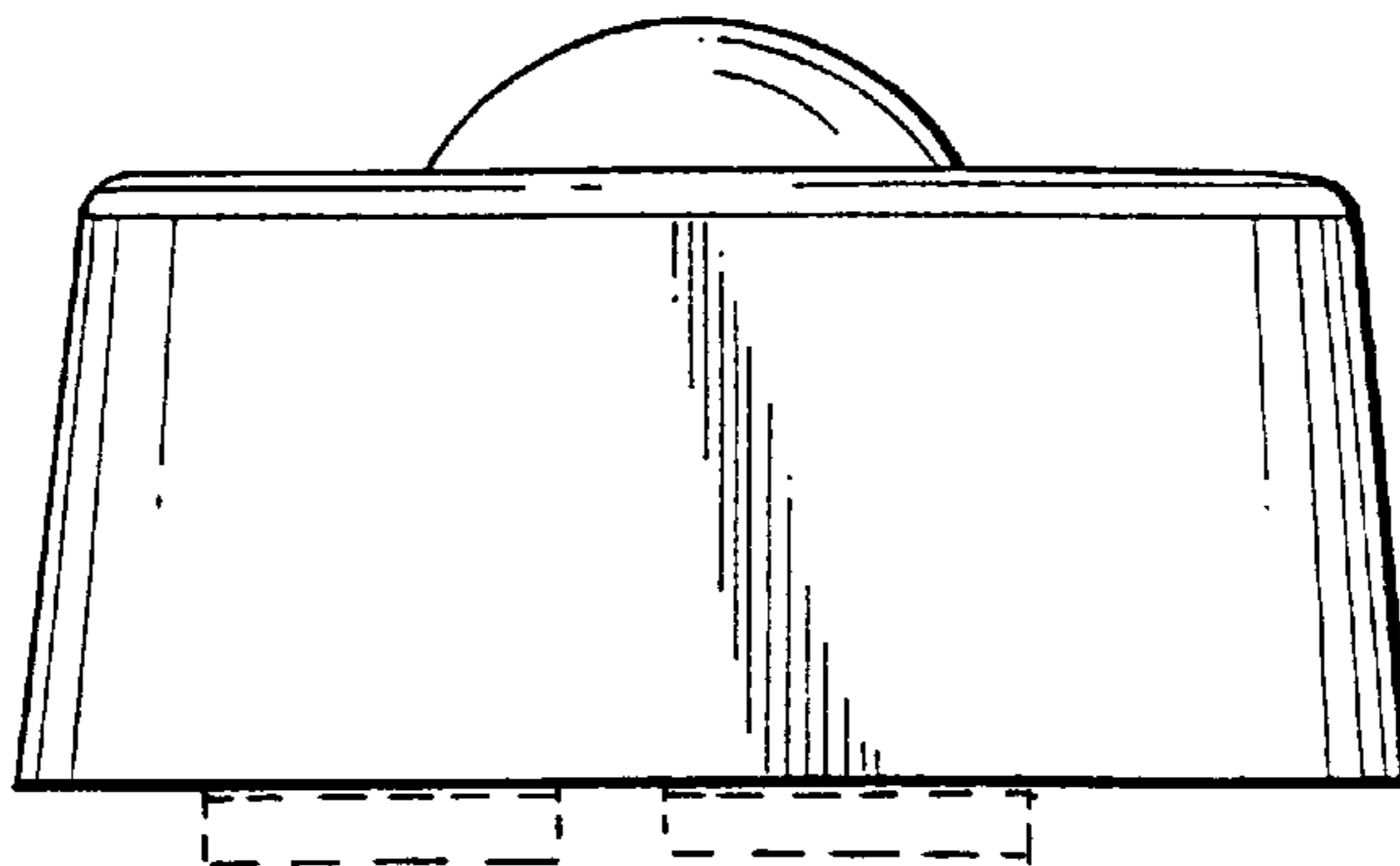

FIG. 14

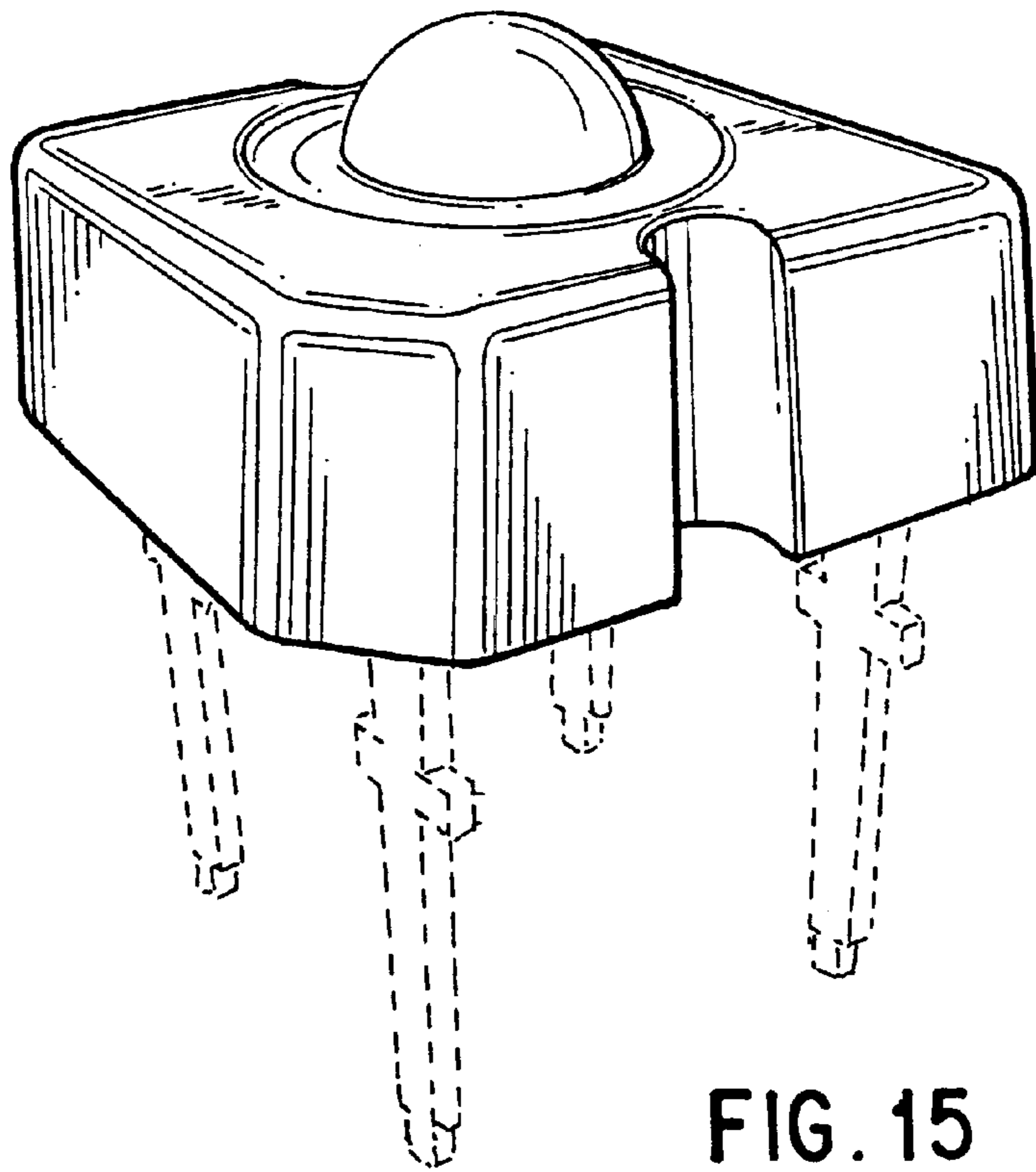

FIG. 15

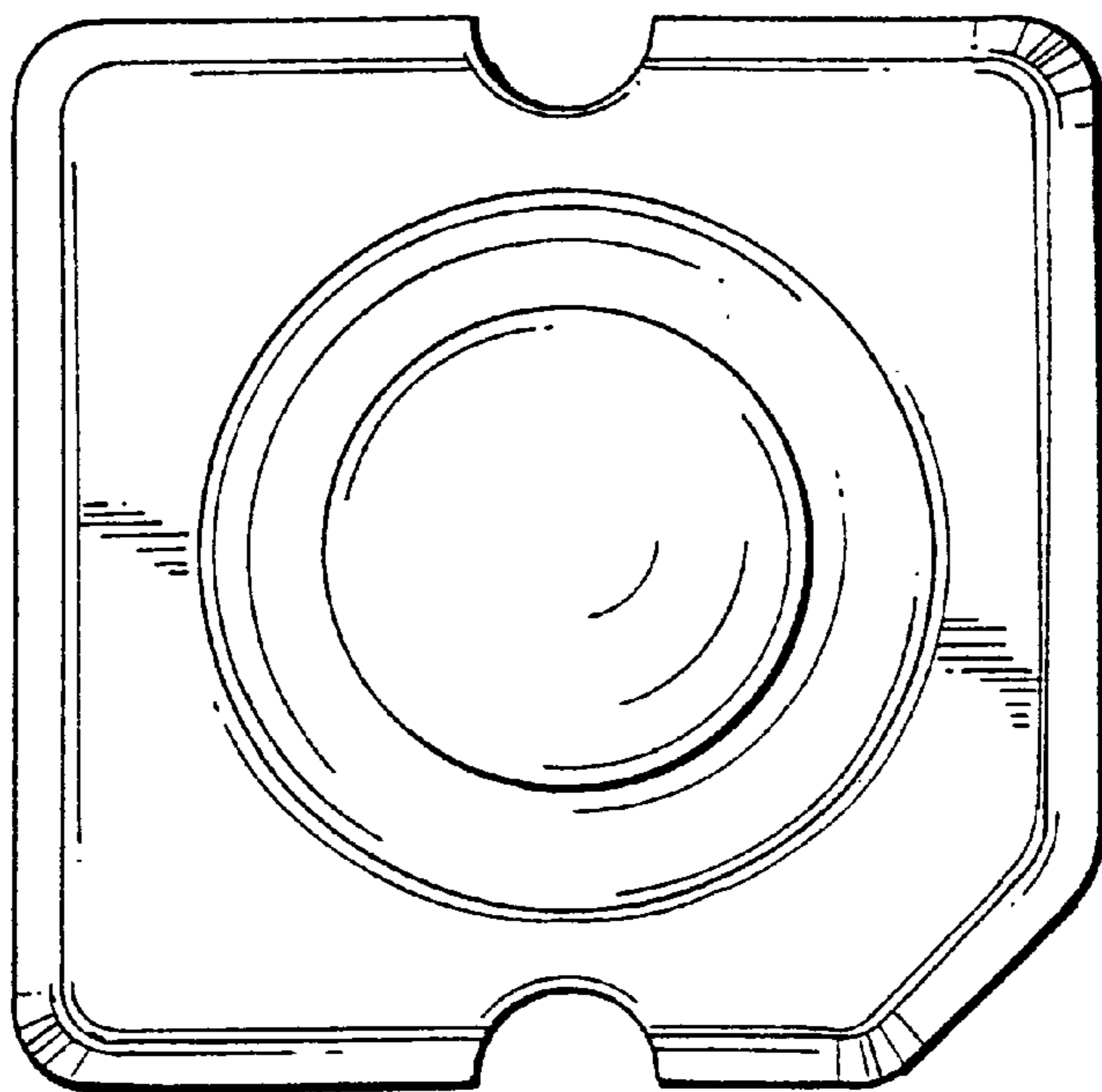

FIG. 16

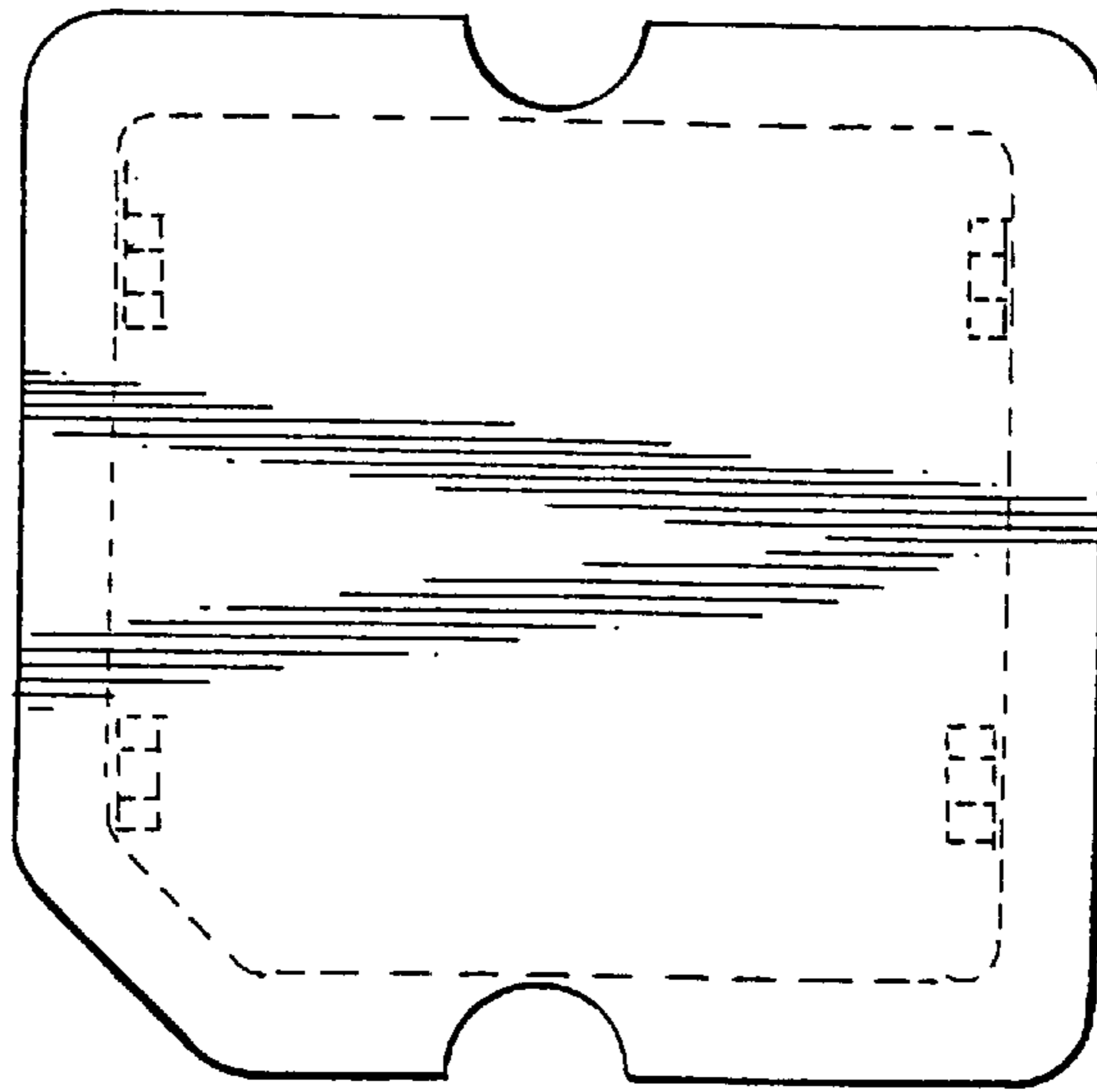

FIG. 17

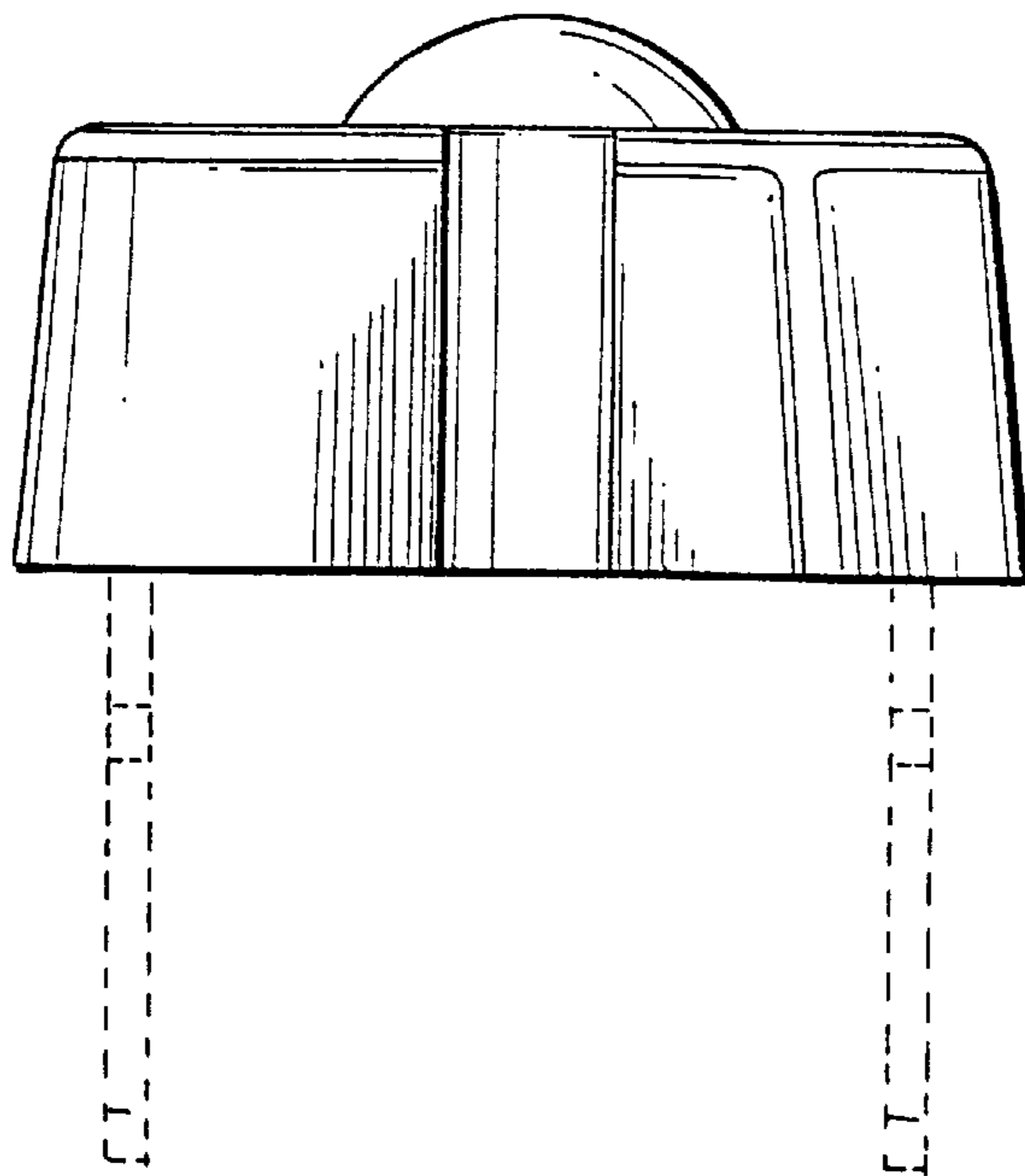

FIG. 18

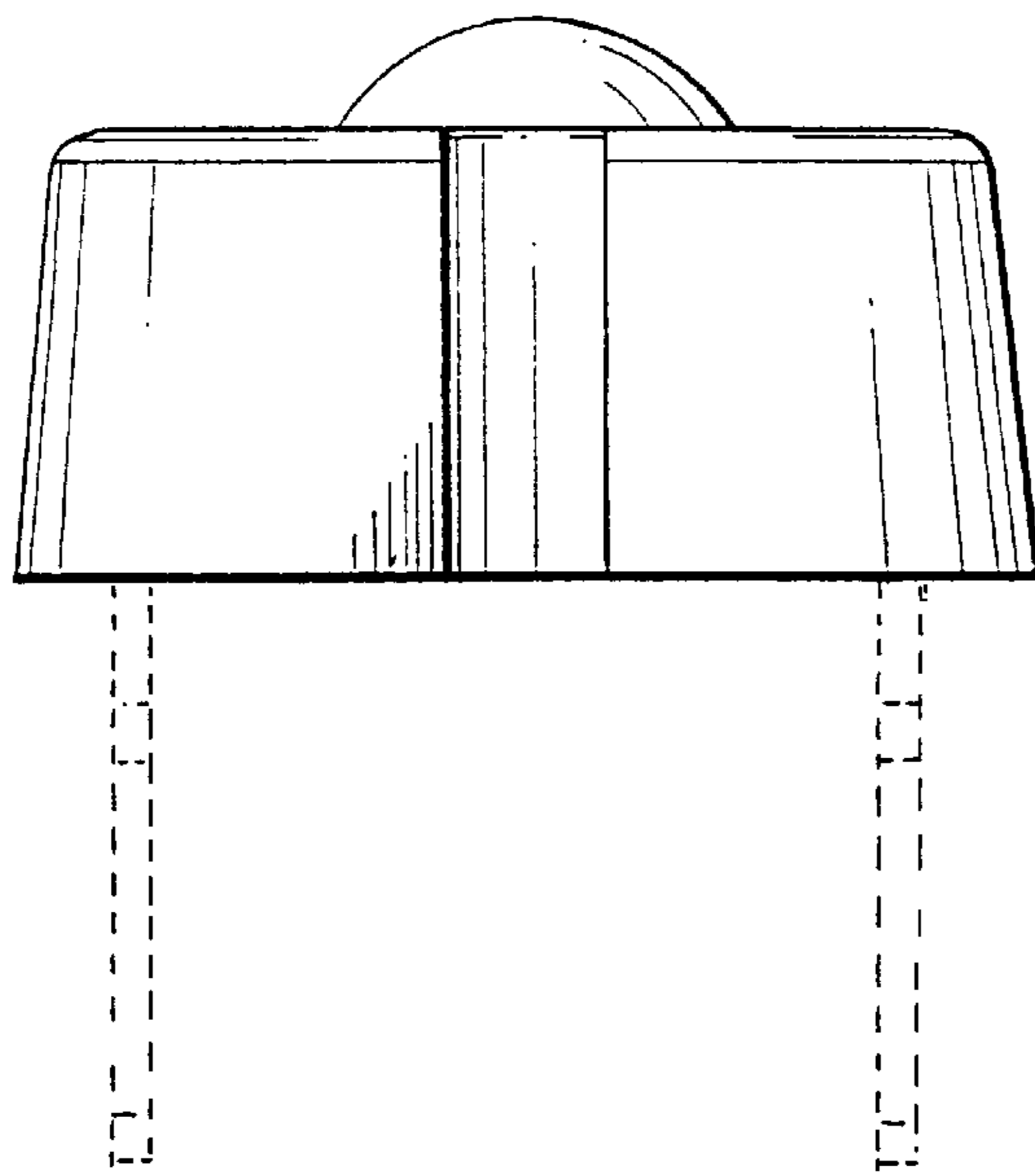

FIG. 19

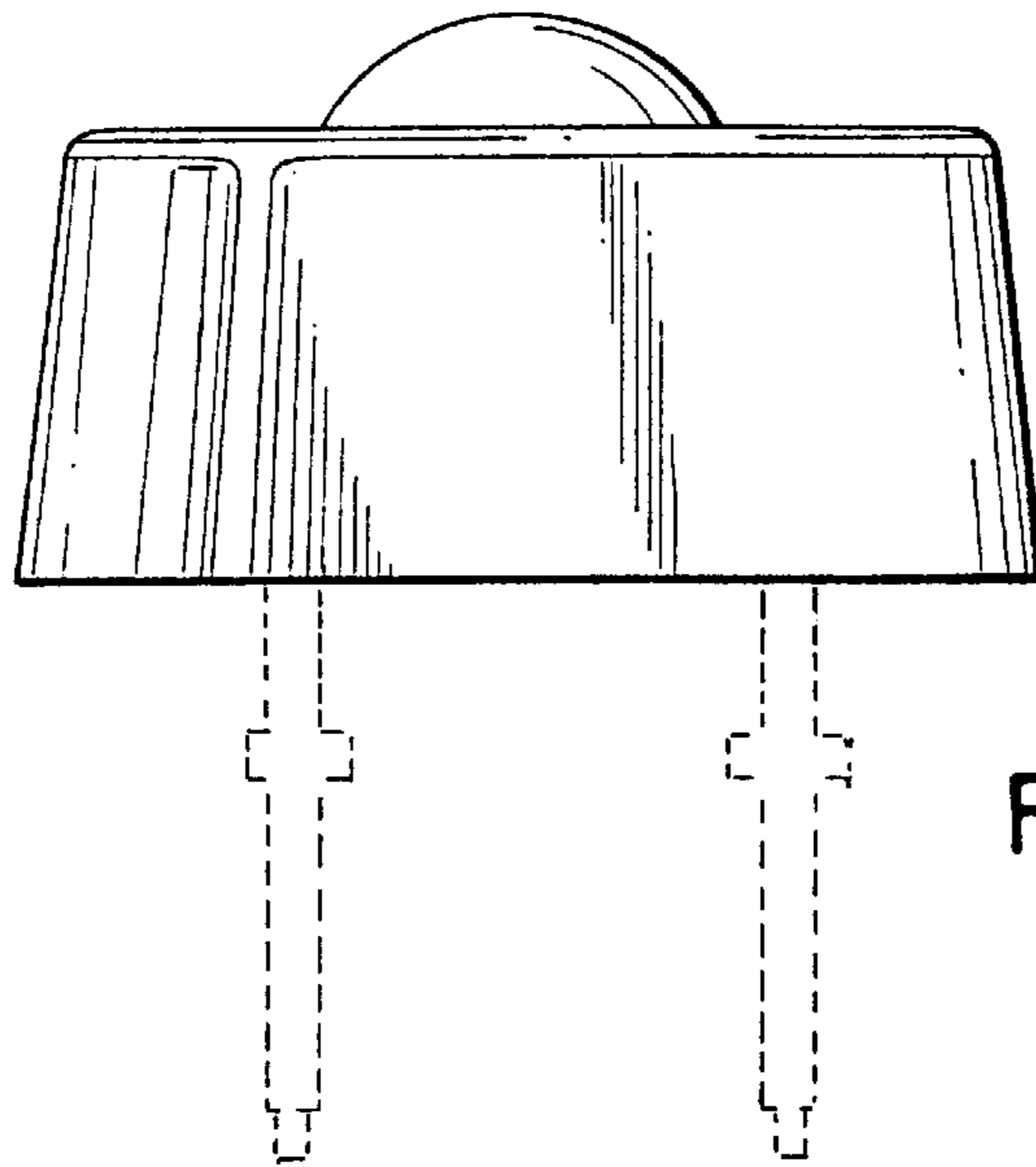

FIG. 20

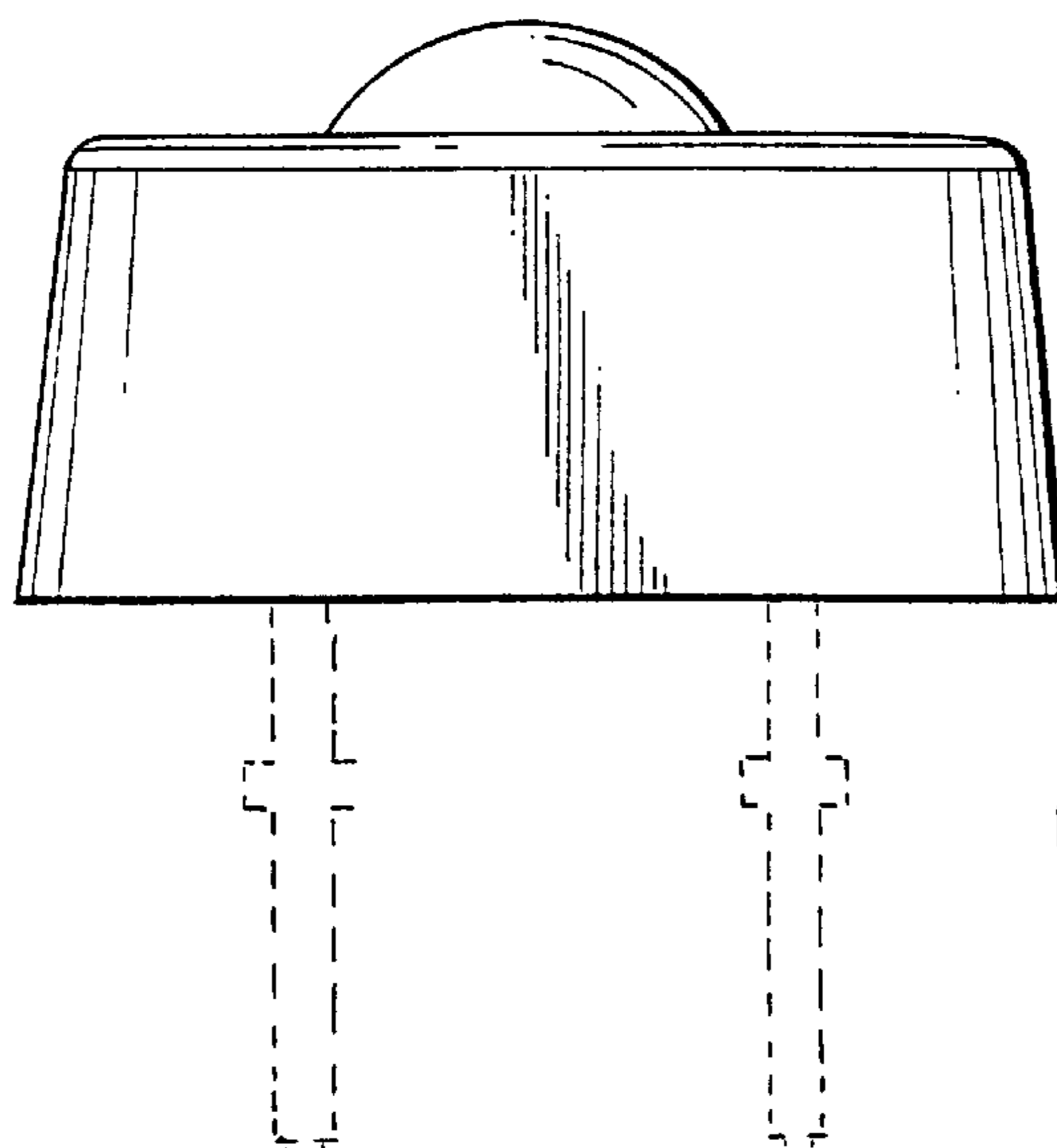

FIG. 21