



US00D432066S

United States Patent [19]

Toyoda

[11] Patent Number: Des. 432,066

[45] Date of Patent: ** Oct. 17, 2000

[54] REAR PORTION OF A MOTOR VEHICLE

[75] Inventor: Tsuyoshi Toyoda, Aki-gun, Japan

[73] Assignee: Mazda Motor Corporation,
Hiroshima-ken, Japan

[**] Term: 14 Years

[21] Appl. No.: 29/111,103

[22] Filed: Sep. 20, 1999

D. 373,342 9/1996 Moore D12/196
D. 376,563 12/1996 Soyo et al. D12/91
D. 395,619 6/1998 Cho D12/91

OTHER PUBLICATIONS

Bulletin Des Dessins Et Modeles Internationaus (International Designs Bulletin), Aug. 1994, Figure DM/030 569, pp. 4529-4530, 4539-4540.

Primary Examiner—Melody N. Brown
Attorney, Agent, or Firm—Sidley & Austin; Hugh A. Abrams

Related U.S. Application Data

[62] Division of application No. 29/094,306, Sep. 30, 1998, Pat. No. Des. 422,254.

Foreign Application Priority Data

Mar. 31, 1998 [JP] Japan 10-9224

[51] LOC (7) Cl. 12-16

[52] U.S. Cl. D12/196

[58] Field of Search D12/196, 169,
D12/90-92; 296/185

References Cited

U.S. PATENT DOCUMENTS

D. 354,258 1/1995 Ikeda D12/91

[57] CLAIM

The ornamental design for a rear portion of a motor vehicle, as shown and described.

DESCRIPTION

FIG. 1 is a perspective view of a rear portion of a motor vehicle showing our new design;
FIG. 2 is a front elevational view thereof;
FIG. 3 is a left side elevational view thereof; and,
FIG. 4 is a top plan view thereof.

The portion of the motor vehicle shown in broken lines is for illustrative purpose only and forms no part of the claimed design.

1 Claim, 4 Drawing Sheets

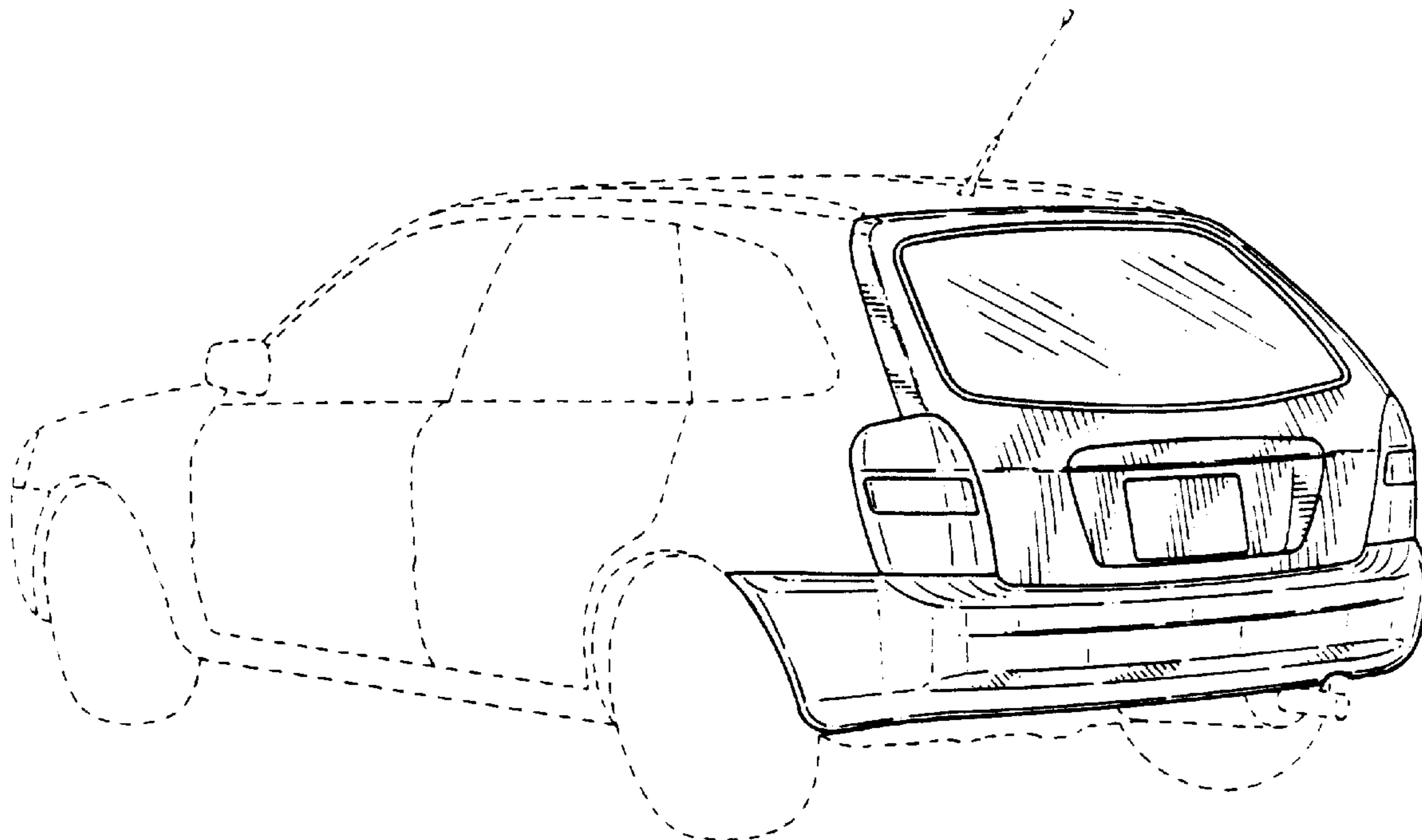

FIG. 1

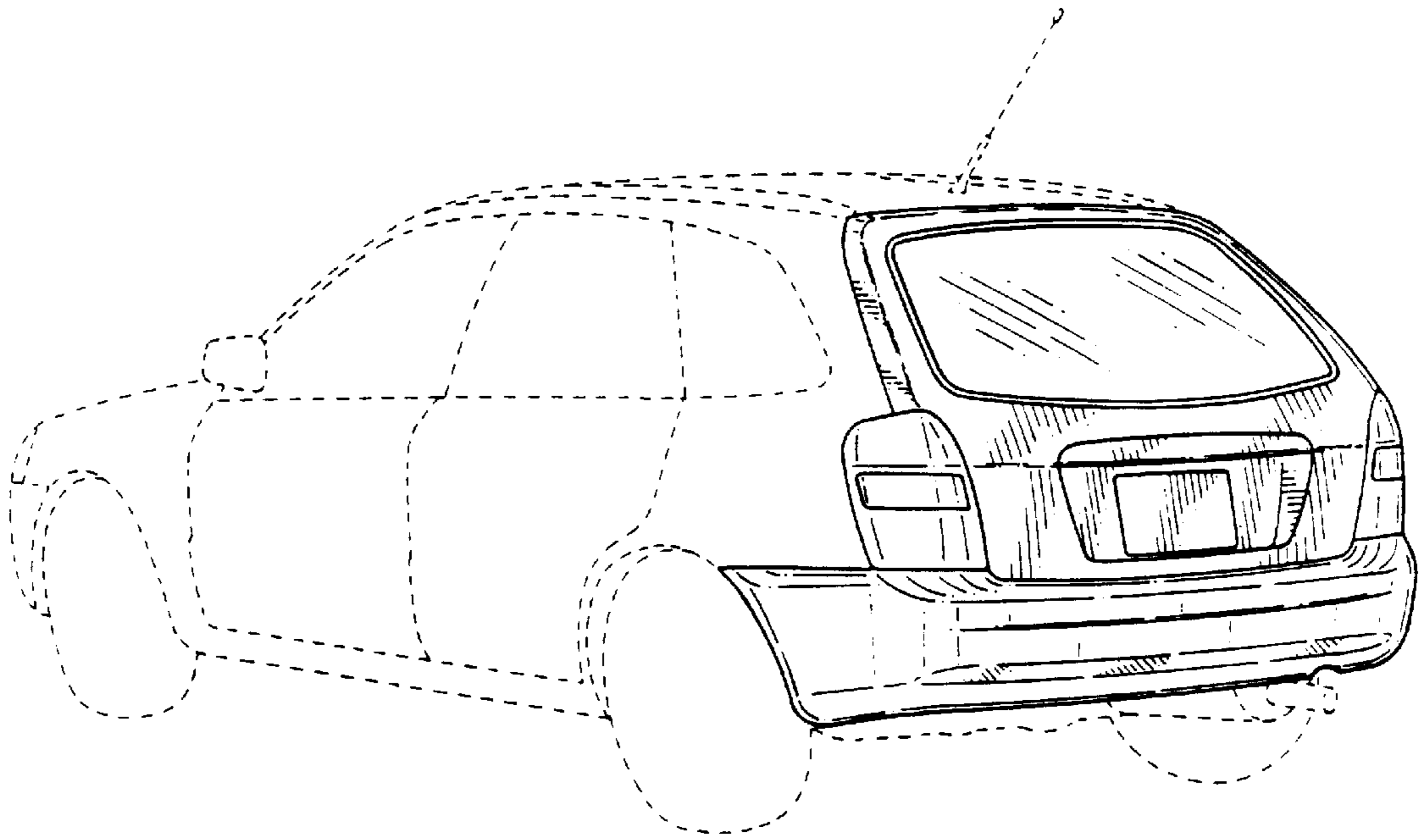

FIG. 2

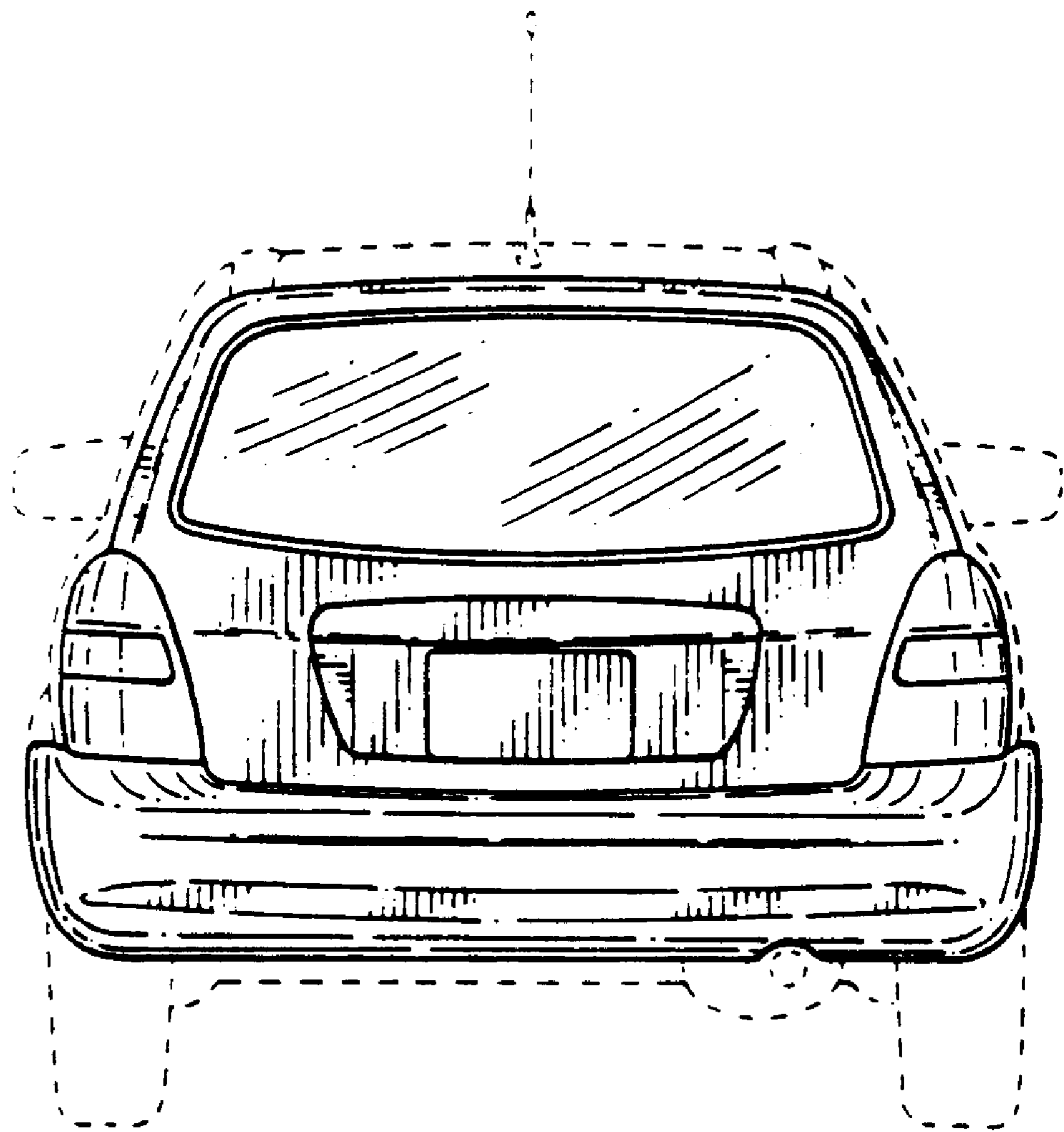

FIG. 3

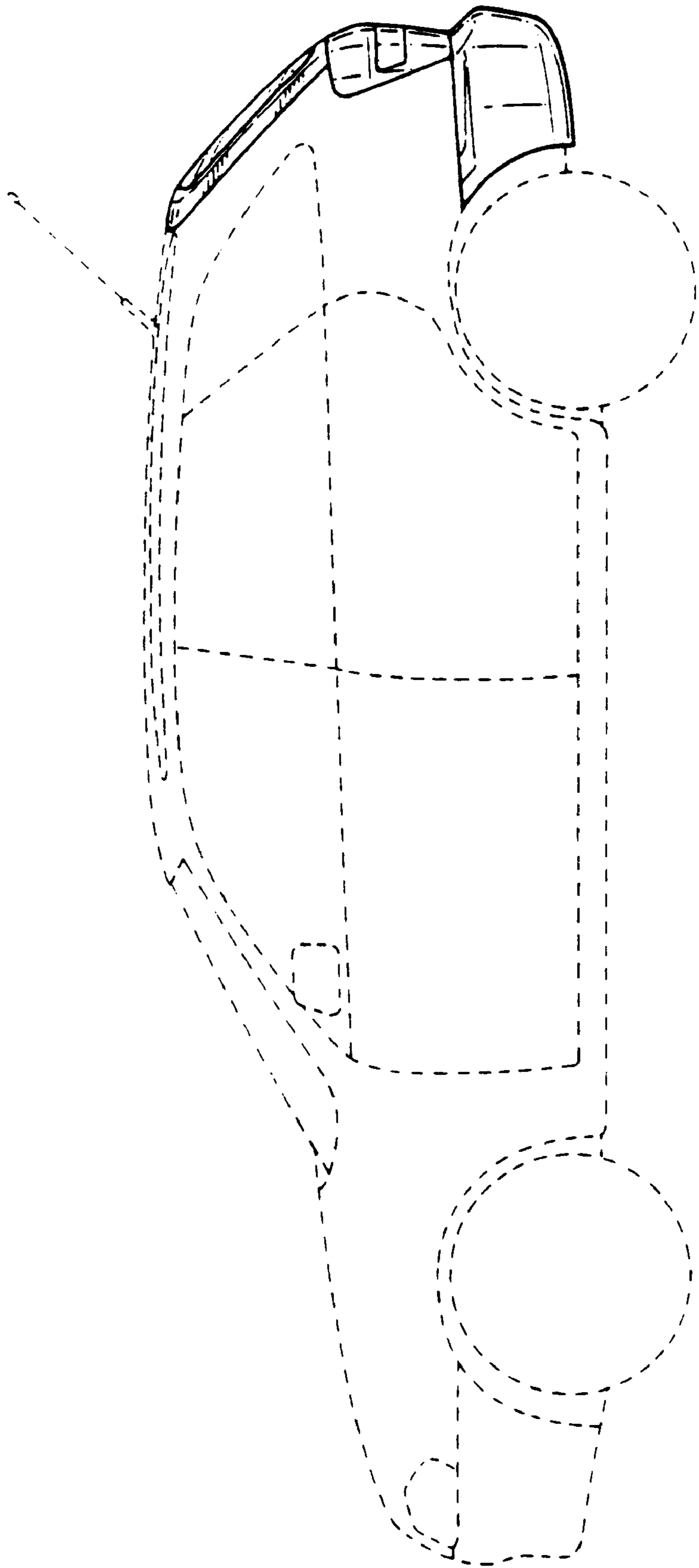

FIG. 4

