

US00D432065S

United States Patent [19]
Kitamura

[11] **Patent Number: Des. 432,065**

[45] **Date of Patent: ** Oct. 17, 2000**

[54] **FRONT PORTION OF A MOTOR VEHICLE**

[75] Inventor: **Eiji Kitamura**, Hiroshima, Japan

[73] Assignee: **Mazda Motor Corporation**,
Hiroshima-Ken, Japan

[**] Term: **14 Years**

[21] Appl. No.: **29/111,084**

[22] Filed: **Sep. 20, 1999**

Related U.S. Application Data

[62] Division of application No. 29/094,209, Sep. 28, 1998.

[51] **LOC (7) Cl.** **12-16**

[52] **U.S. Cl.** **D12/196; D12/163**

[58] **Field of Search** D12/163, 169,
D12/90-92; 180/68.1, 68.6, 69.21; 293/102,
115

[56] **References Cited**

U.S. PATENT DOCUMENTS

- D. 373,331 9/1996 Ohkura et al. .
- D. 416,841 11/1999 Akana D12/196
- D. 417,425 12/1999 Shimozu D12/196

OTHER PUBLICATIONS

Foreign Language Document entitled "New Capella", catalogue, p. 15, dated Sep. 16, 1997 cited in Notice of Reasons

for Rejection dated Apr. 28, 2000 from Japanese Patent Office.

Primary Examiner—Melody N. Brown
Attorney, Agent, or Firm—Sidley & Austin; Hugh A. Abrams

[57] **CLAIM**

The ornamental design for a front portion of a motor vehicle, as shown and described.

DESCRIPTION

FIG. 1 is a perspective view of a front portion of a motor vehicle showing our new design;
 FIG. 2 is a front elevational view thereof;
 FIG. 3 is a rear elevational view thereof;
 FIG. 4 is a left side elevational view thereof;
 FIG. 5 is a top plan view thereof;
 FIG. 6 is a perspective view of a front portion of a vehicle showing a second embodiment of our new design;
 FIG. 7 is a front elevational view of FIG. 6;
 FIG. 8 is a rear elevational view of FIG. 6;
 FIG. 9 is a right side elevational view of FIG. 6; and,
 FIG. 10 is a front elevational view of FIG. 6.

The portion of the motor vehicle shown in broken lines is for illustrative purpose only and forms no part of the claimed design.

1 Claim, 8 Drawing Sheets

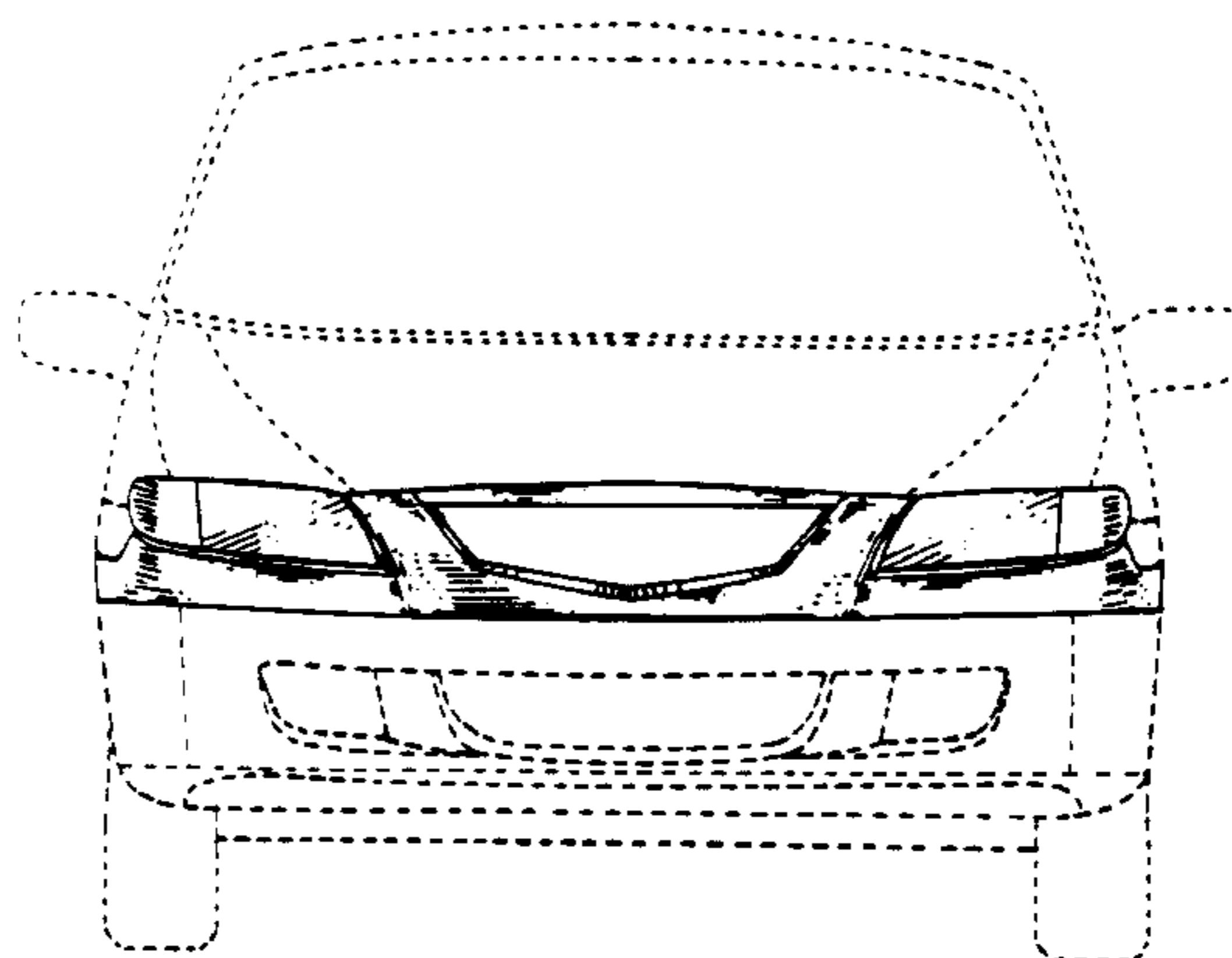
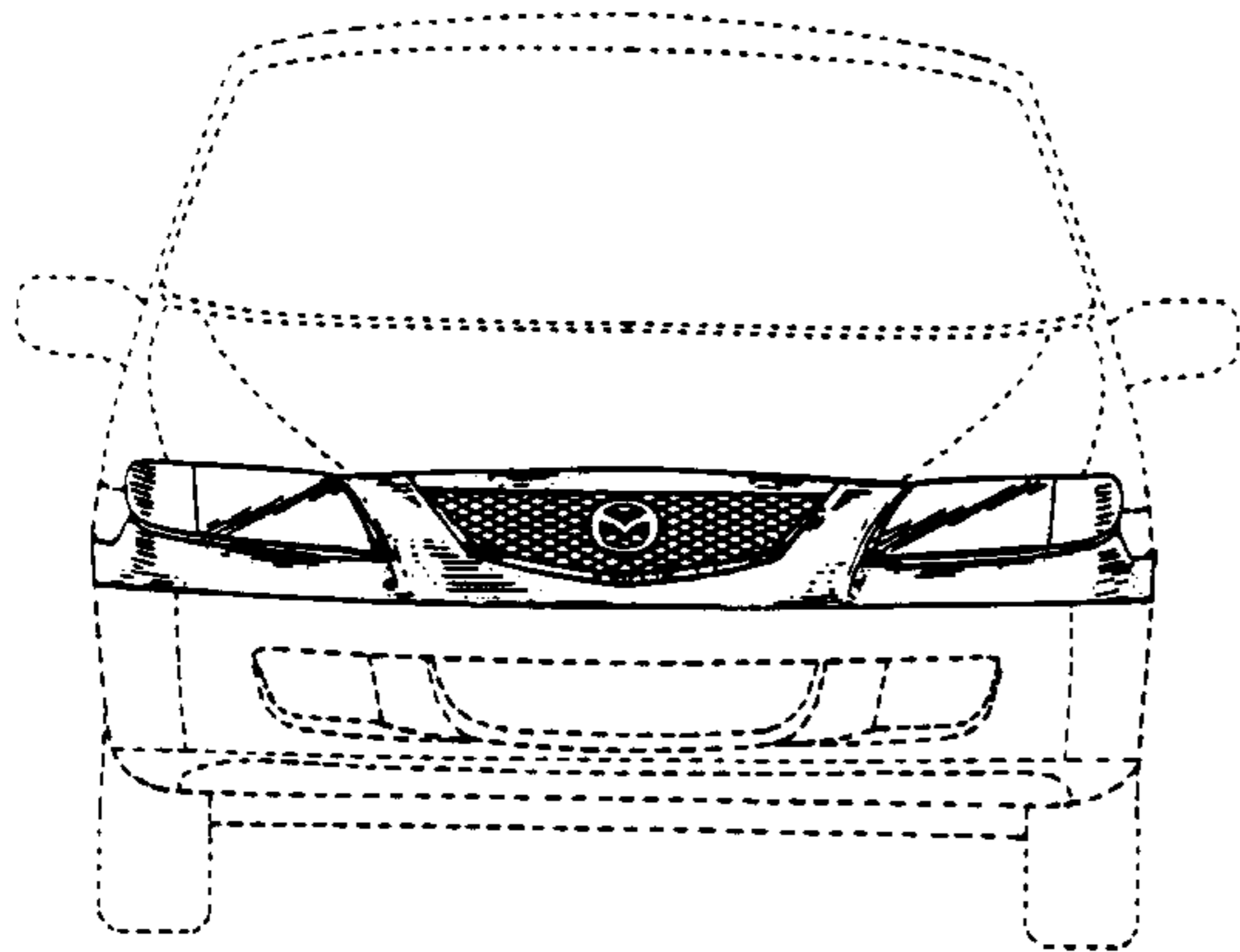

FIG. 1

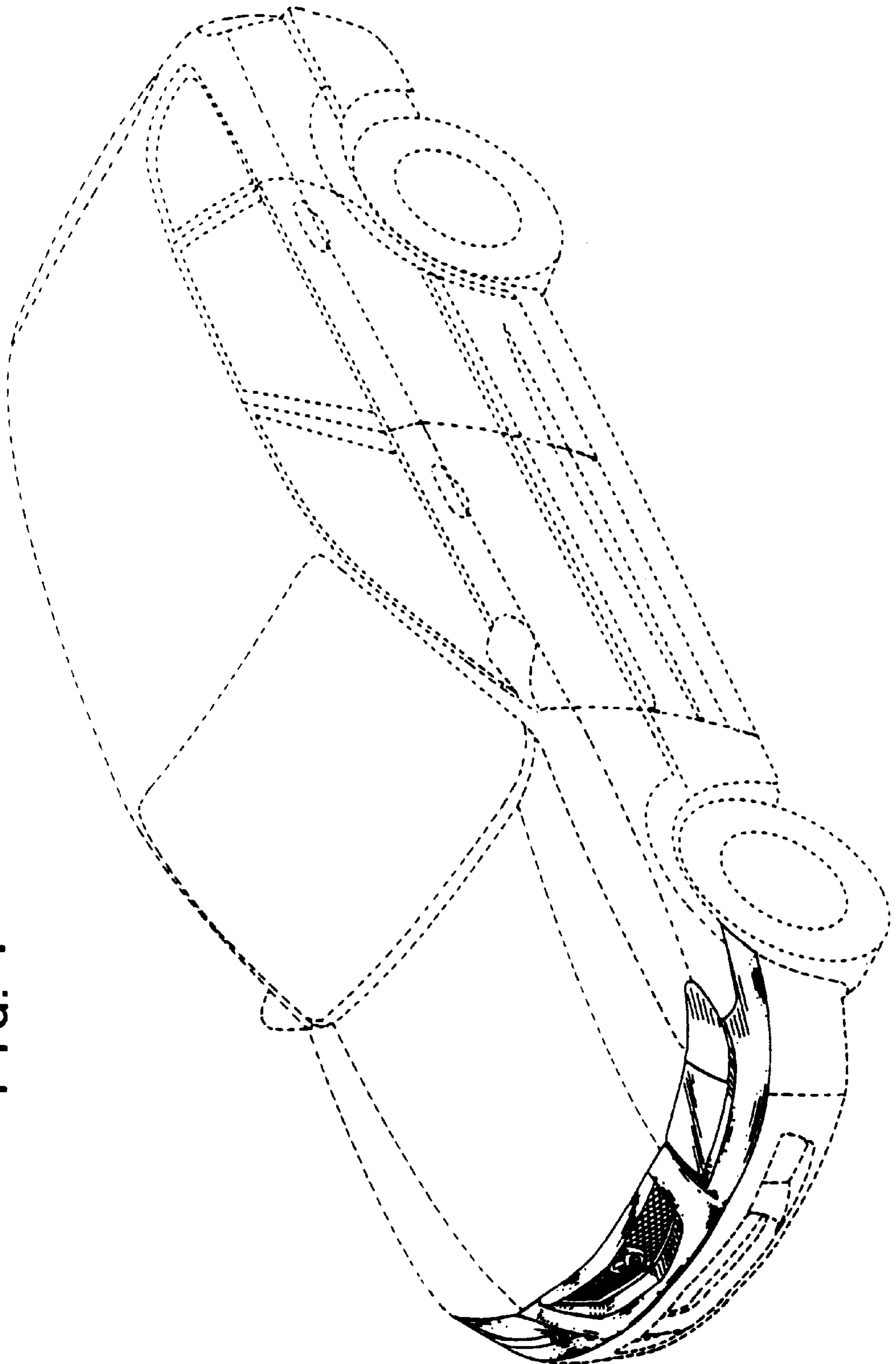

FIG. 2

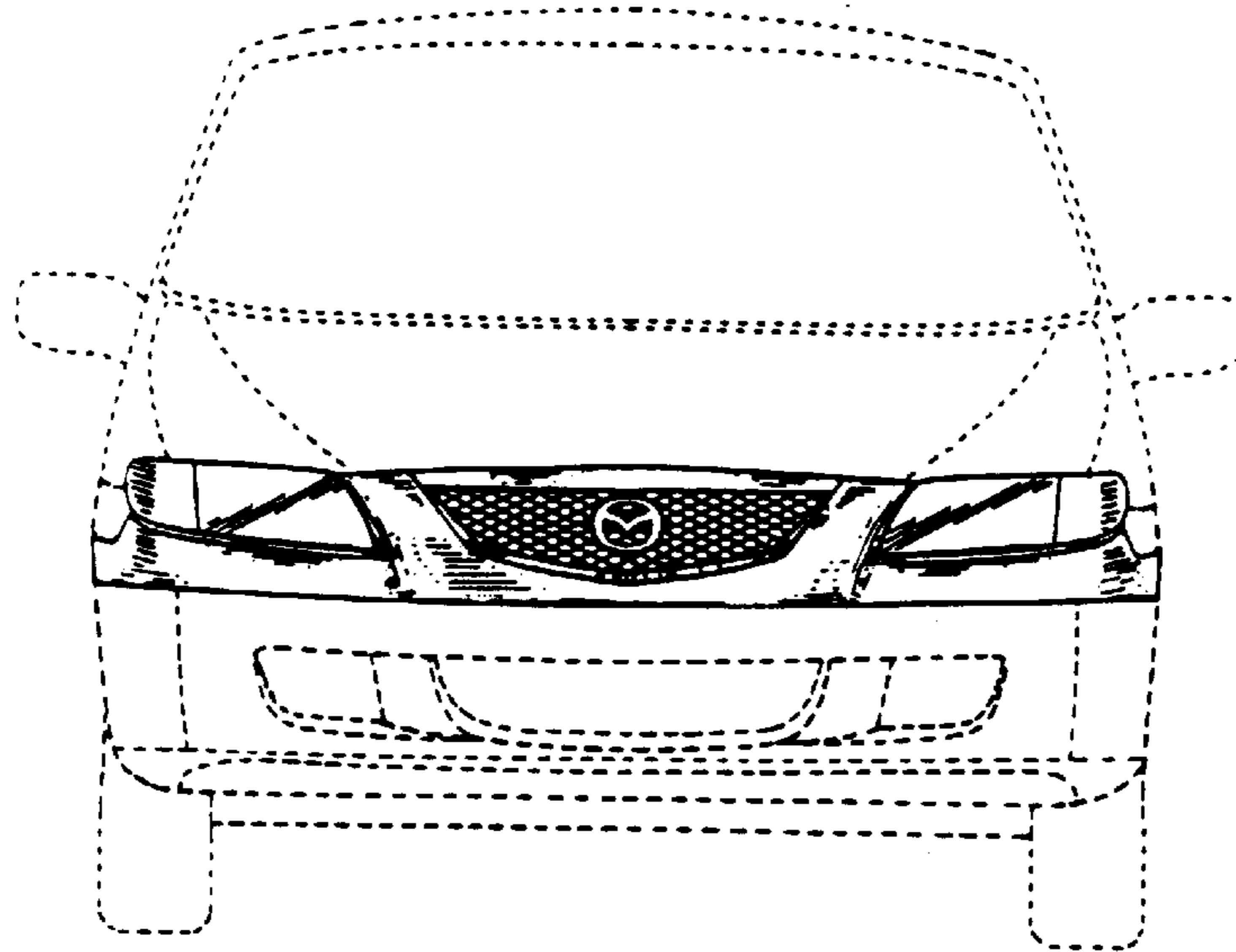

FIG. 3

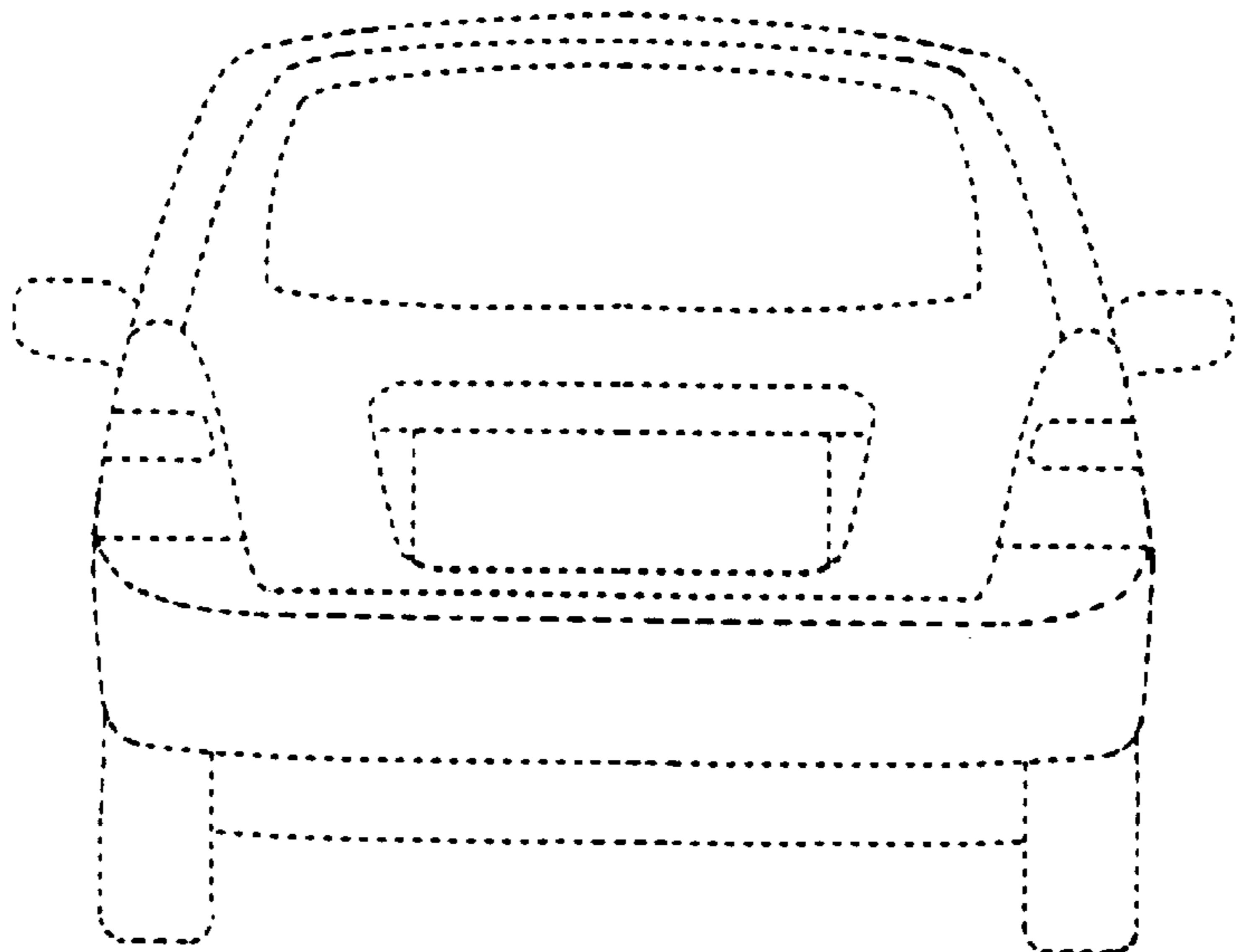

FIG. 4

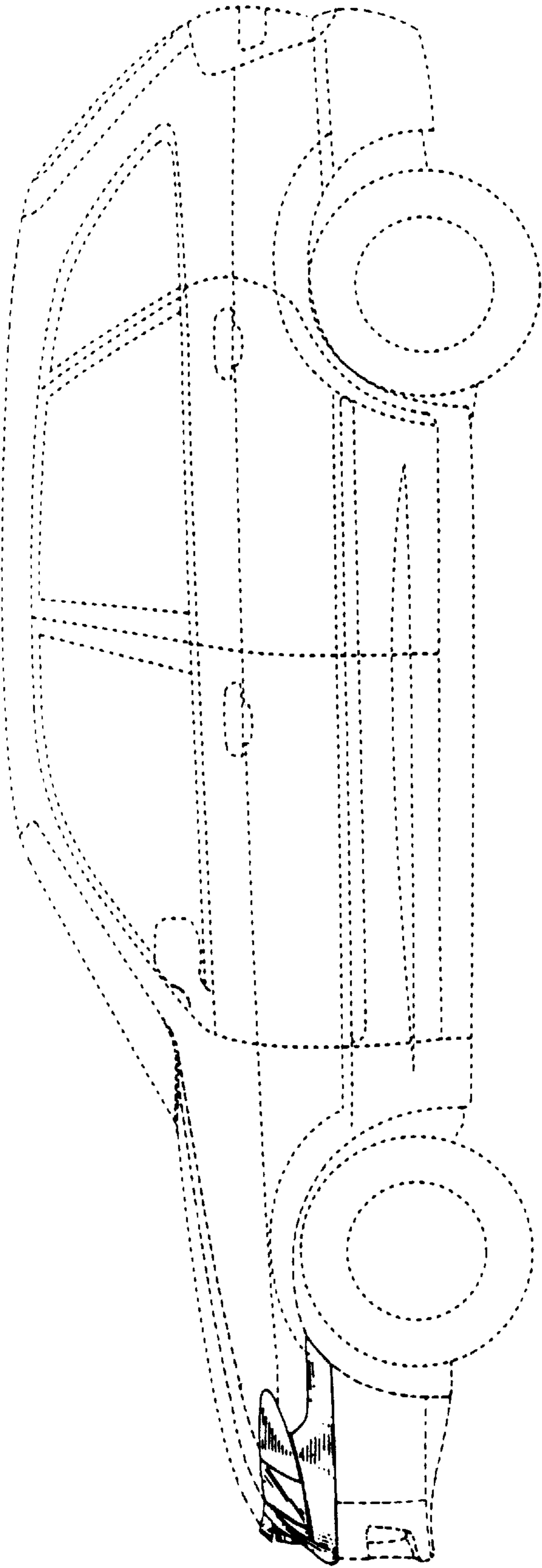

FIG. 5

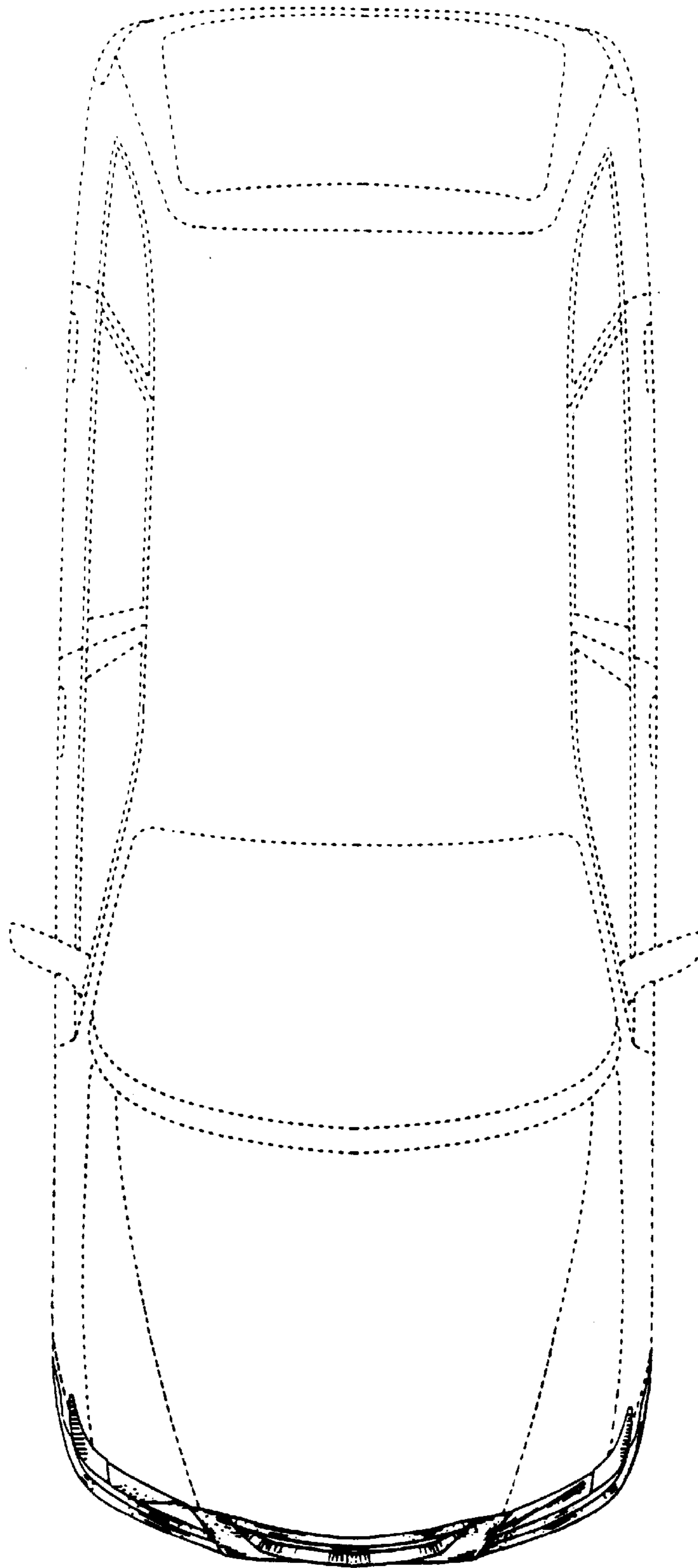

FIG. 6

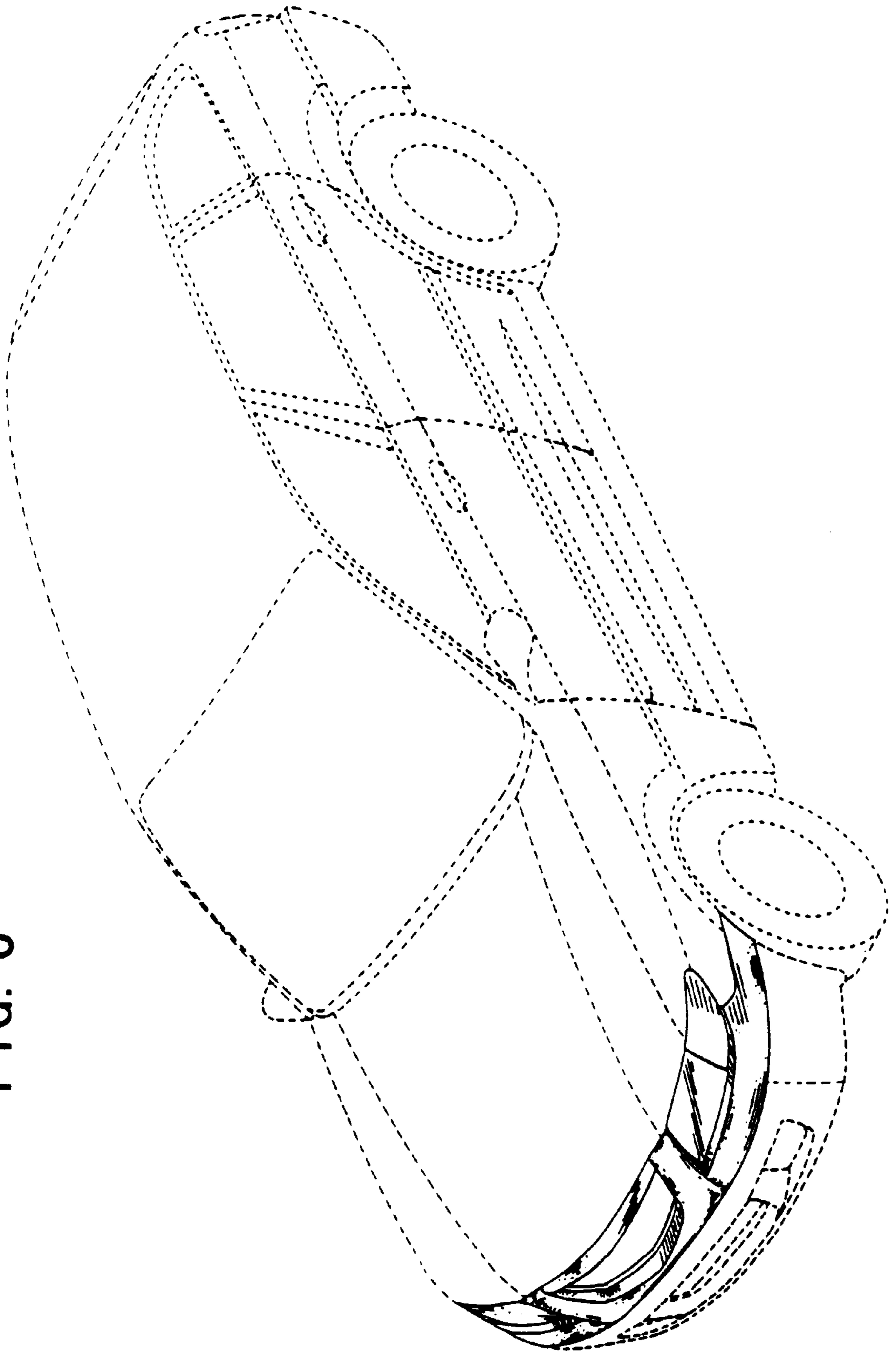

FIG. 7

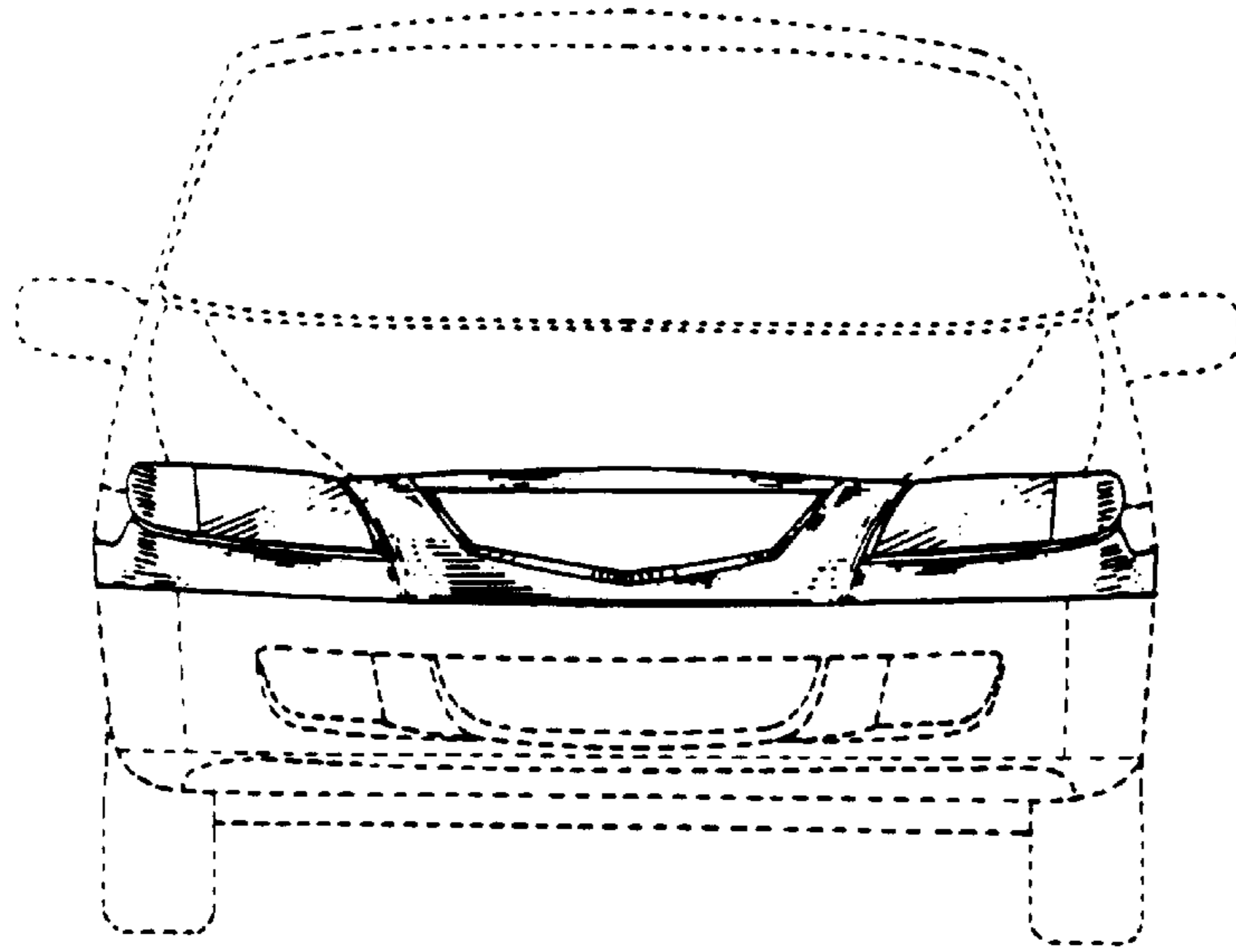

FIG. 8

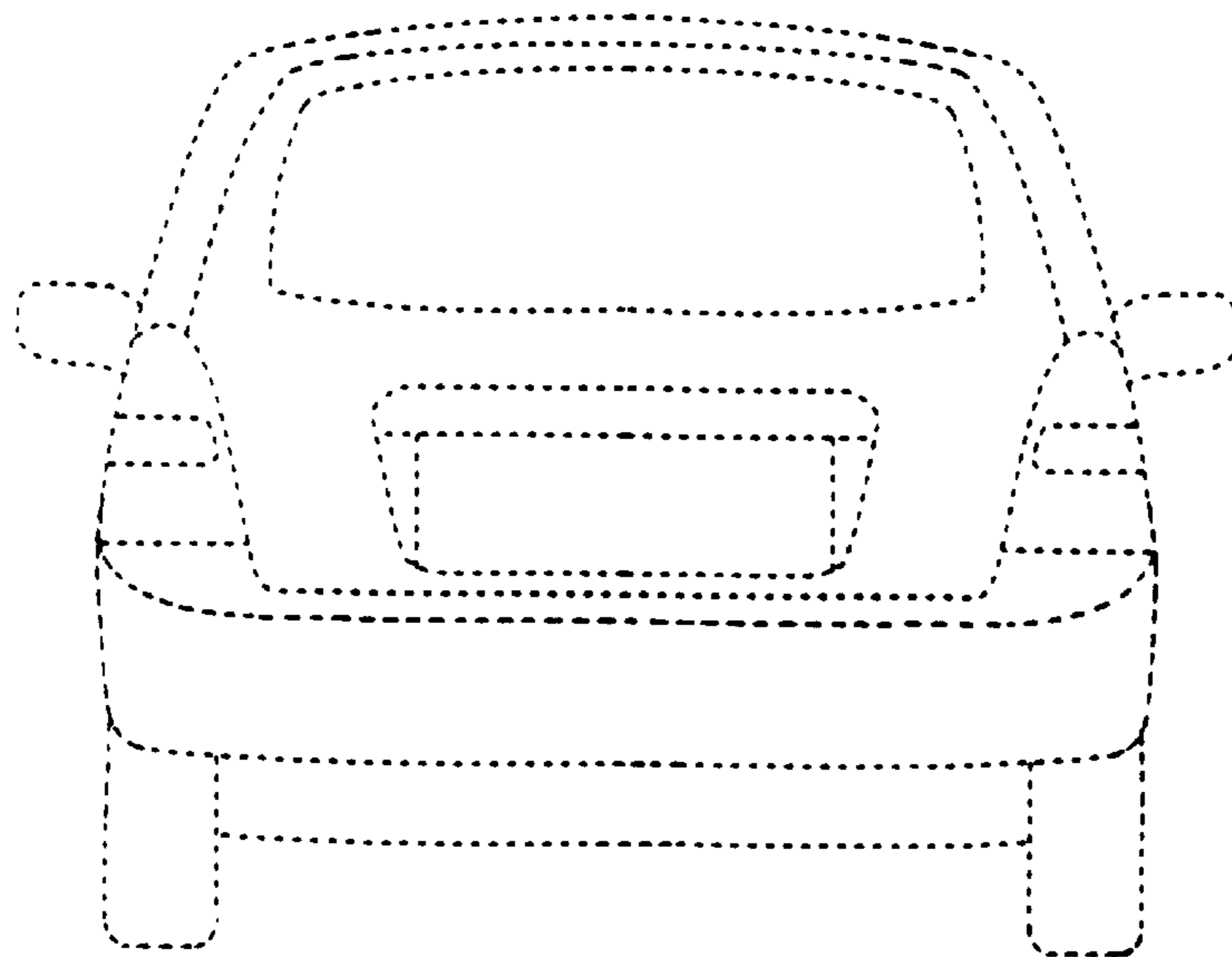

FIG. 9

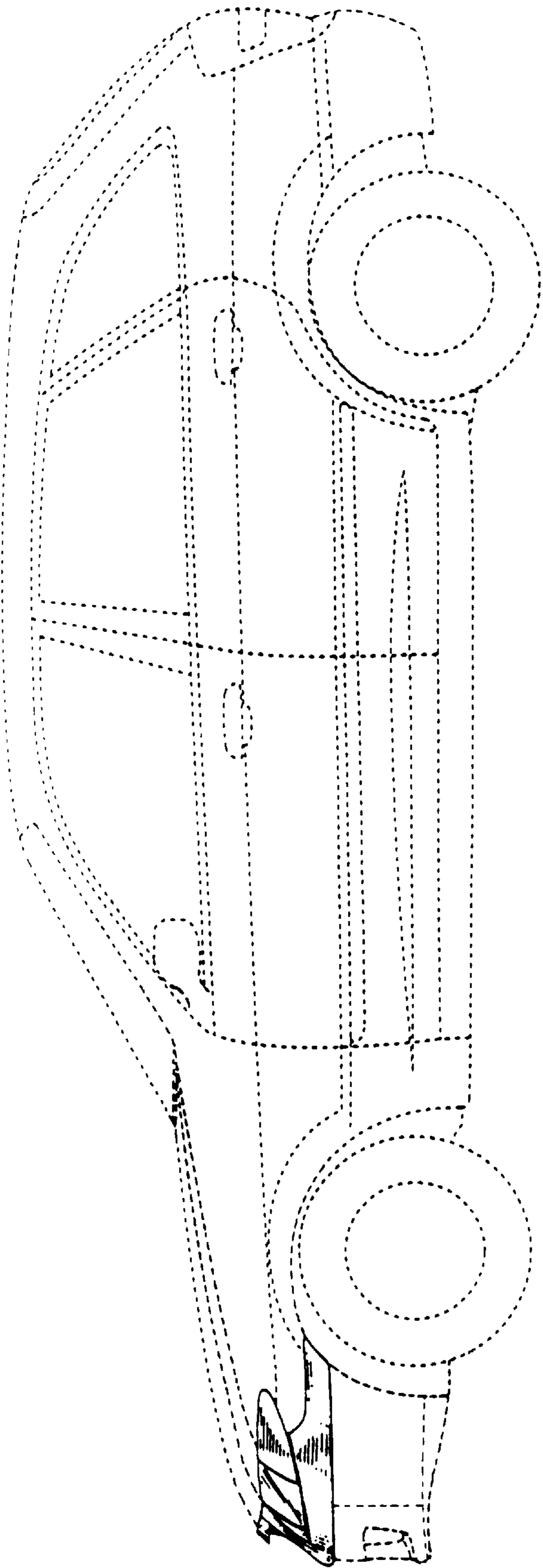

FIG. 10

