



US00D432052S

United States Patent [19]

[11] Patent Number: Des. 432,052

Ayoub et al.

[45] Date of Patent: ** Oct. 17, 2000

[54] AUTOMOBILE BODY

[75] Inventors: Patrick Ayoub, Clarkston; John D. Bucci, Rochester Hills; Ernest J. Barry; Robert N. Hubbach, both of Clarkston, all of Mich.; Thomas G. Tremont, San Diego, Calif.; Kevin R. Verduyn; William L. Chergosky, both of Carlsbad, Calif.; K. Neil Walling, Leonard, Mich.

D. 394,829	6/1998	Hubbach et al.	D12/92
D. 396,664	8/1998	Boniface et al.	D12/92
D. 408,328	4/1999	Ayoub et al.	D12/92
D. 413,083	8/1999	Odette et al.	D12/92
D. 415,069	10/1999	Odette et al.	D12/92
D. 419,487	1/2000	Schneldes et al.	D12/92

[73] Assignee: DaimlerChrysler Corporation, Auburn Hills, Mich.

Primary Examiner—Melody N. Brown
Attorney, Agent, or Firm—Mark P. Calcaterra

[**] Term: 14 Years

[57] CLAIM

[21] Appl. No.: 29/112,725

The ornamental design for an automobile body, as shown and described.

[22] Filed: Oct. 22, 1999

DESCRIPTION

[51] LOC (7) Cl. 12-08

[52] U.S. Cl. D12/92

[58] Field of Search D12/90-92; 296/185

FIG. 1 is a front perspective view illustrating a first embodiment of an automobile body constructed in accordance with the teachings of the present invention.

FIG. 2 is a rear perspective view thereof.

FIG. 3 is a right side view thereof, it will be understood that the side opposite to that shown is a substantial mirror image thereof.

FIG. 4 is a front view thereof.

FIG. 5 is a rear view thereof.

FIG. 6 is a front perspective view of a second embodiment of an automobile body constructed in accordance with the teachings of the present invention, it being understood that differences between the second embodiment and the first embodiment are limited to the horizontally extending contour on the sides, it further being understood that the side opposite to that shown is a substantial mirror image thereof.

FIG. 7 is a rear perspective view of FIG. 6.

FIG. 8 is a right side view of FIG. 6.

FIG. 9 is a front view of FIG. 6; and,

FIG. 10 is a rear view of FIG. 6.

It will be understood that the broken line showing of the wheels and tires throughout the drawings is for illustrative purposes only and forms no part of the subject invention.

[56] References Cited

U.S. PATENT DOCUMENTS

D. 294,337	2/1988	Reed et al.	D12/90
D. 336,736	6/1993	Verduyn	D12/91
D. 345,324	3/1994	Bucci et al.	D12/92
D. 346,769	5/1994	Ackerman et al.	D12/92
D. 346,771	5/1994	Verduyn	D12/92
D. 347,200	5/1994	Anness et al.	D12/92
D. 350,086	8/1994	Kong et al.	D12/92
D. 351,124	10/1994	Dehner et al.	D12/92
D. 354,459	1/1995	Honarkhah et al.	D12/92
D. 356,758	3/1995	Ackerman et al.	D12/92
D. 358,568	5/1995	Ackerman	D12/92
D. 361,046	8/1995	Watkins et al.	D12/92
D. 370,646	6/1996	Verduyn	D12/91
D. 370,876	6/1996	Santoro et al.	D12/92
D. 378,203	2/1997	Huang	D12/92
D. 391,522	3/1998	Hall et al.	D12/92

1 Claim, 8 Drawing Sheets

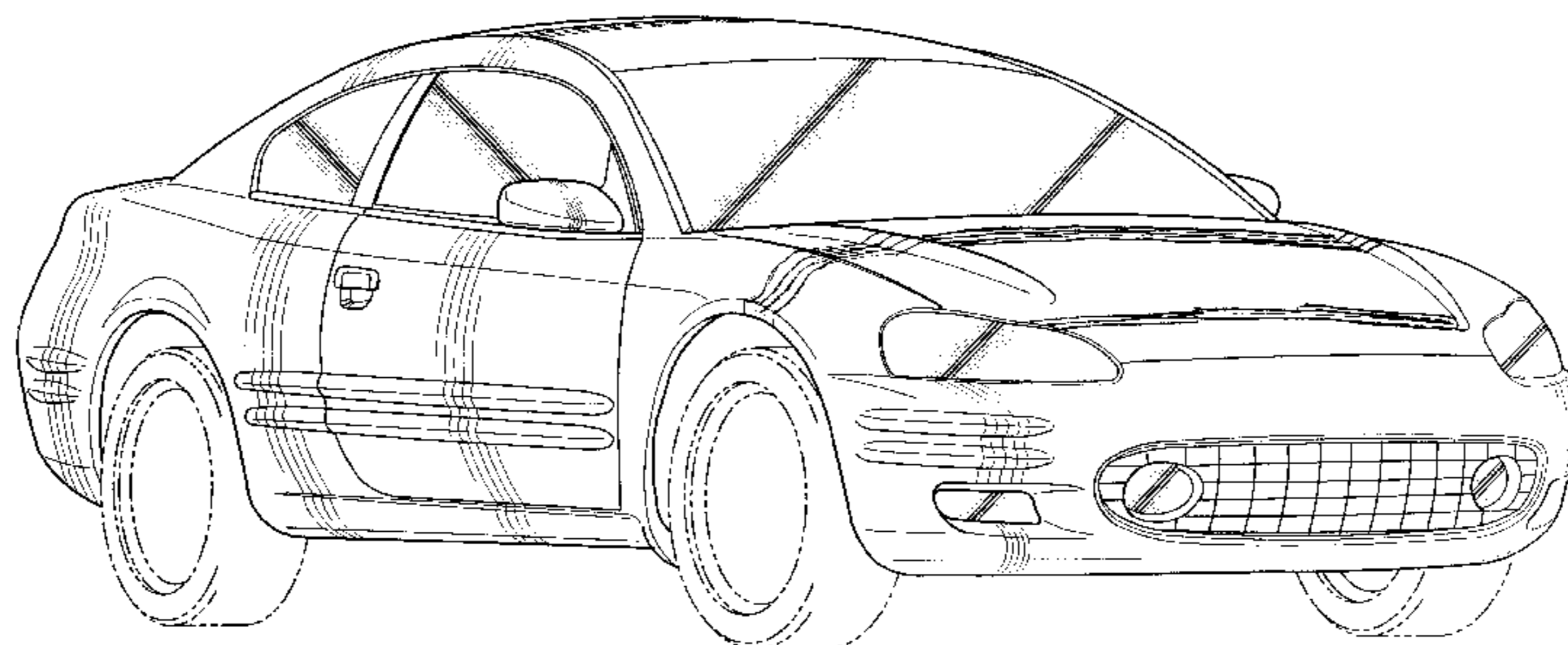
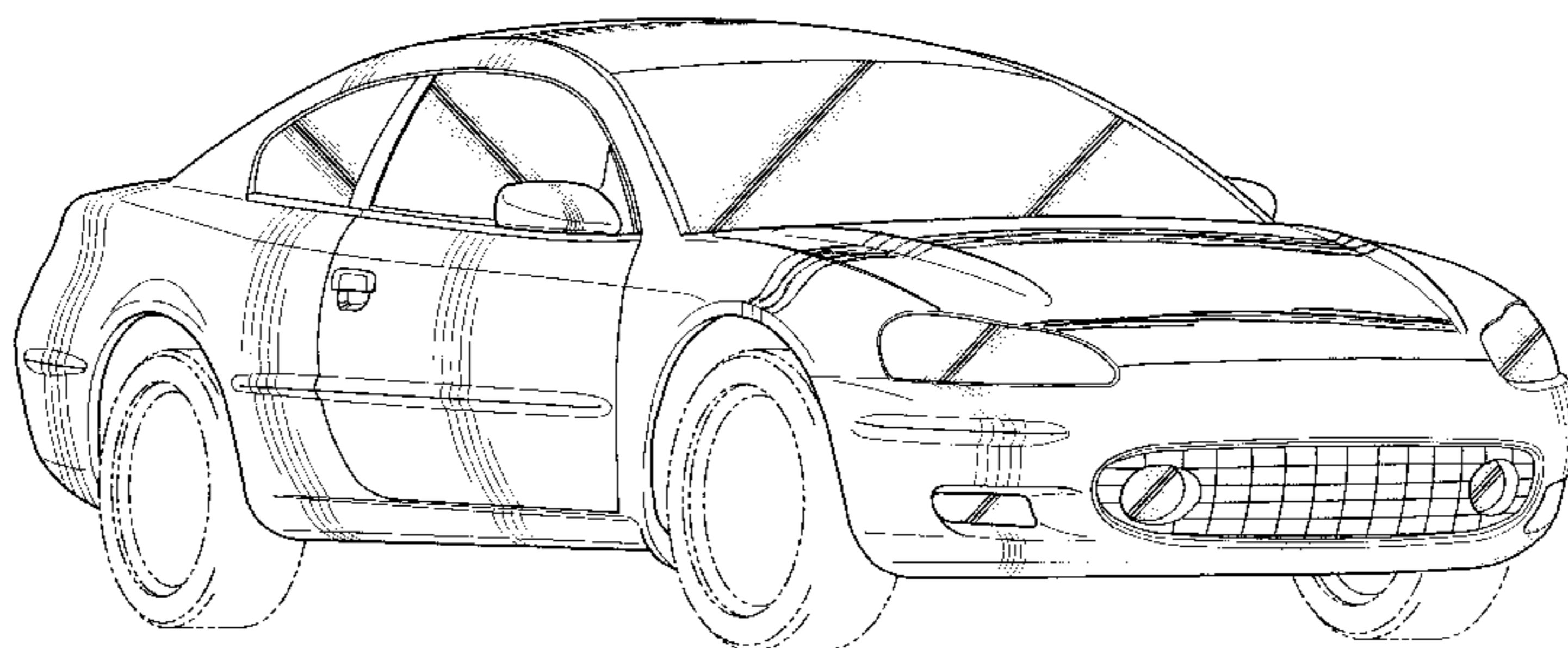

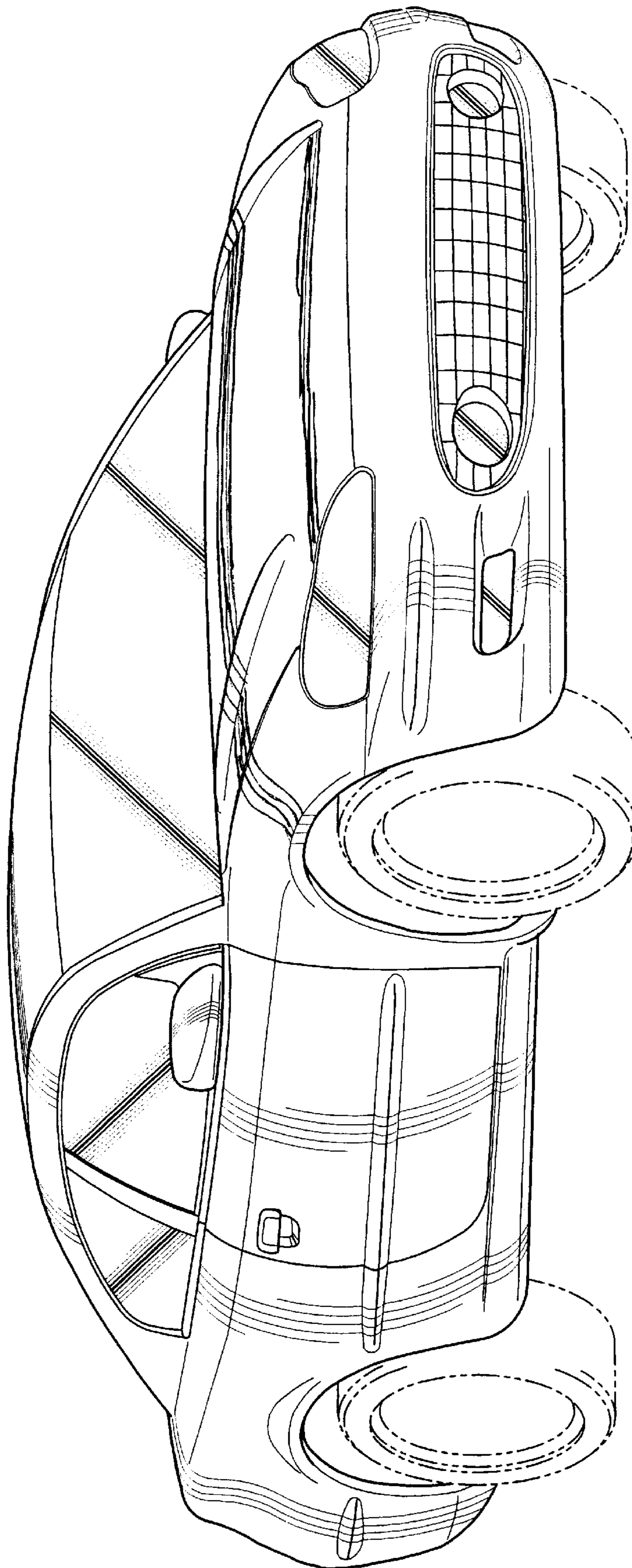

Fig. 1

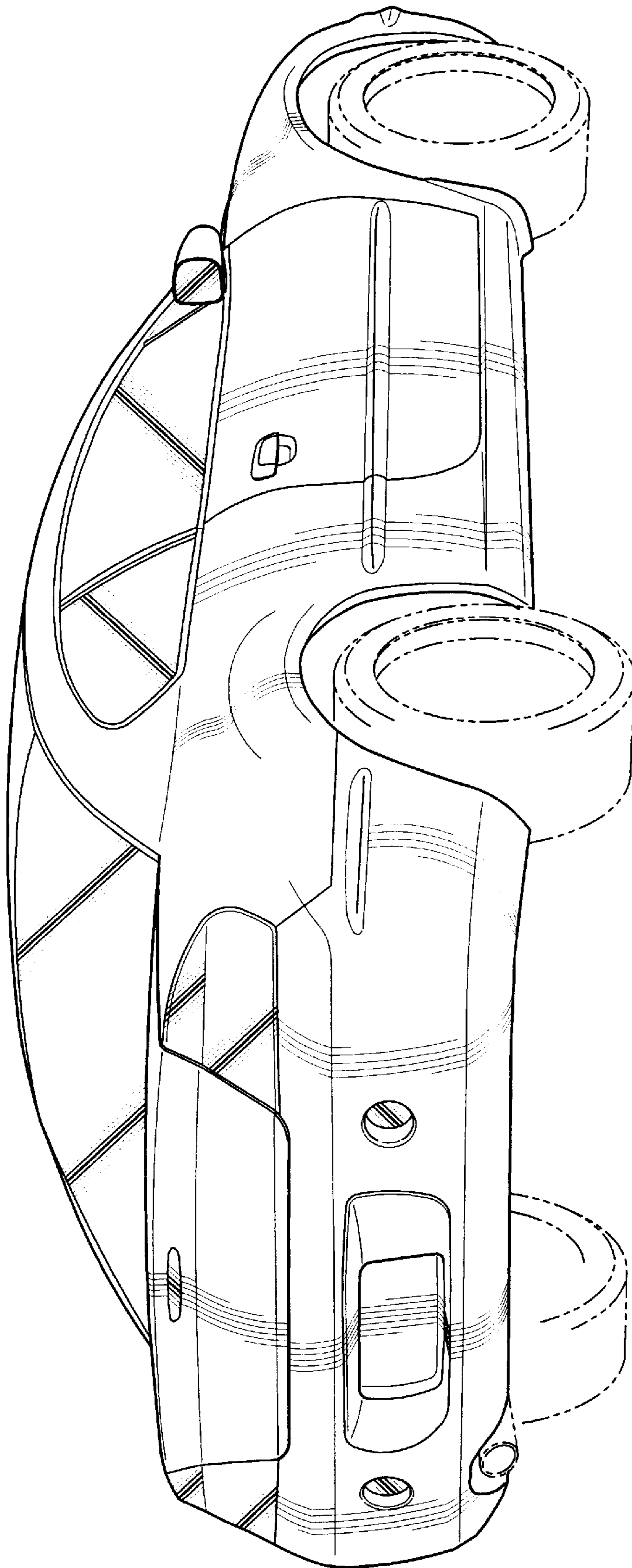

Fig-2

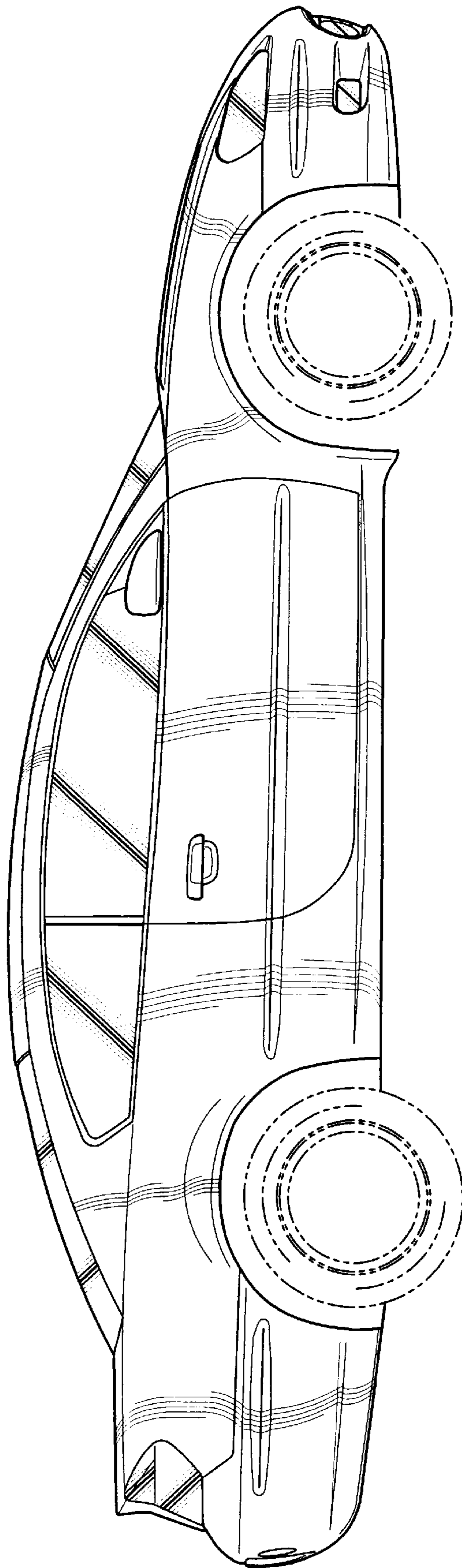

Fig-3

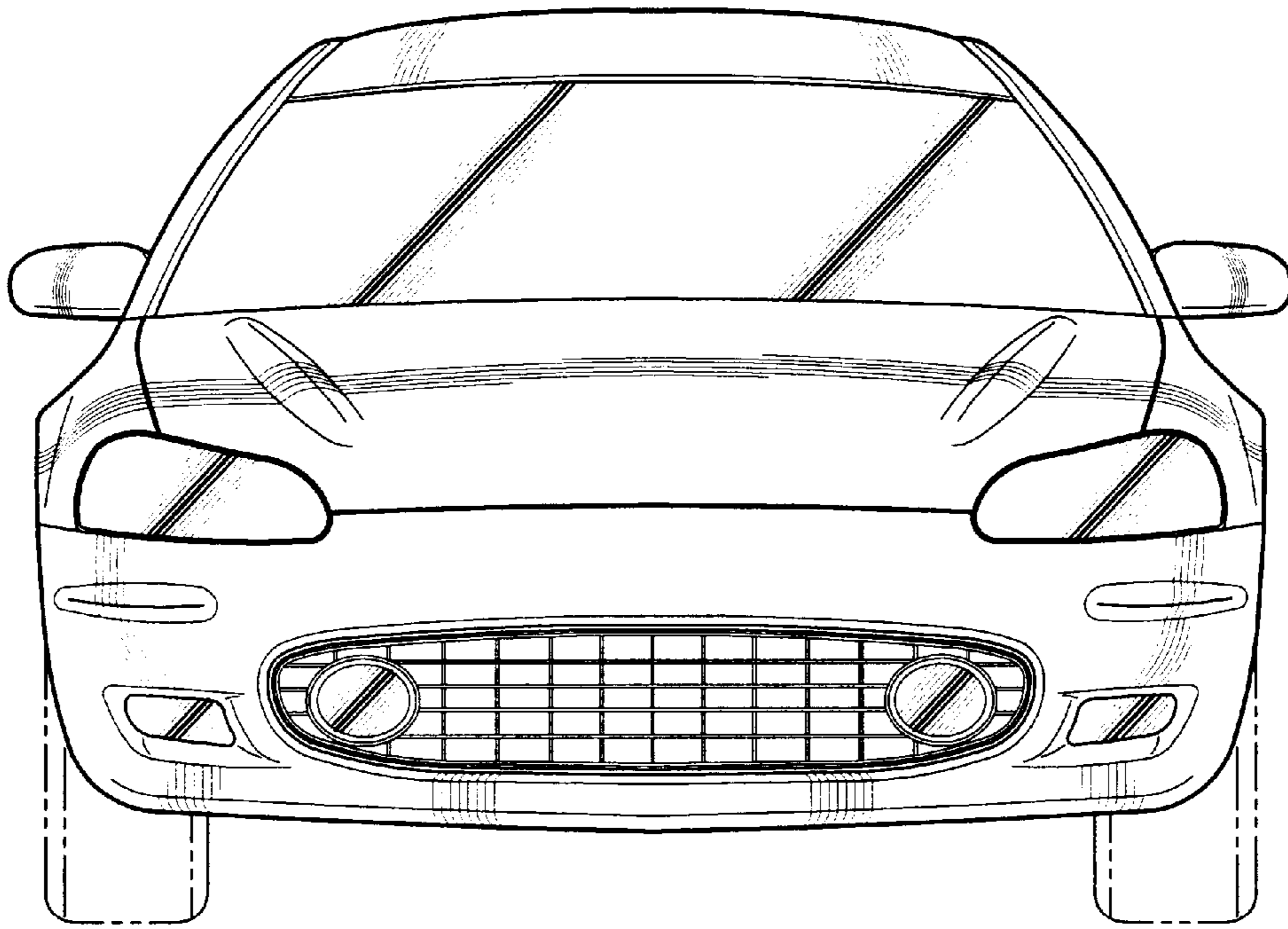

Fig-4

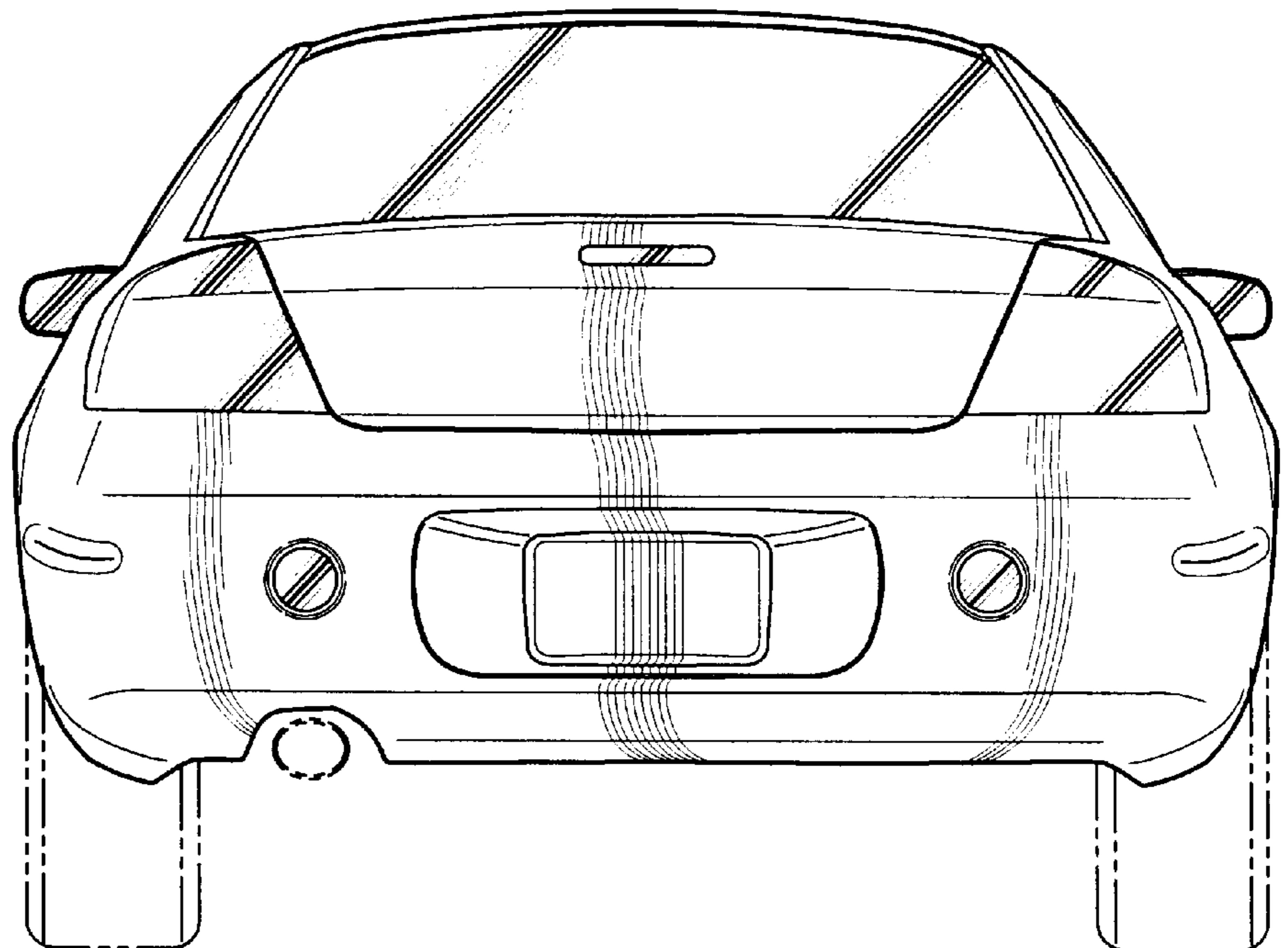

Fig-5

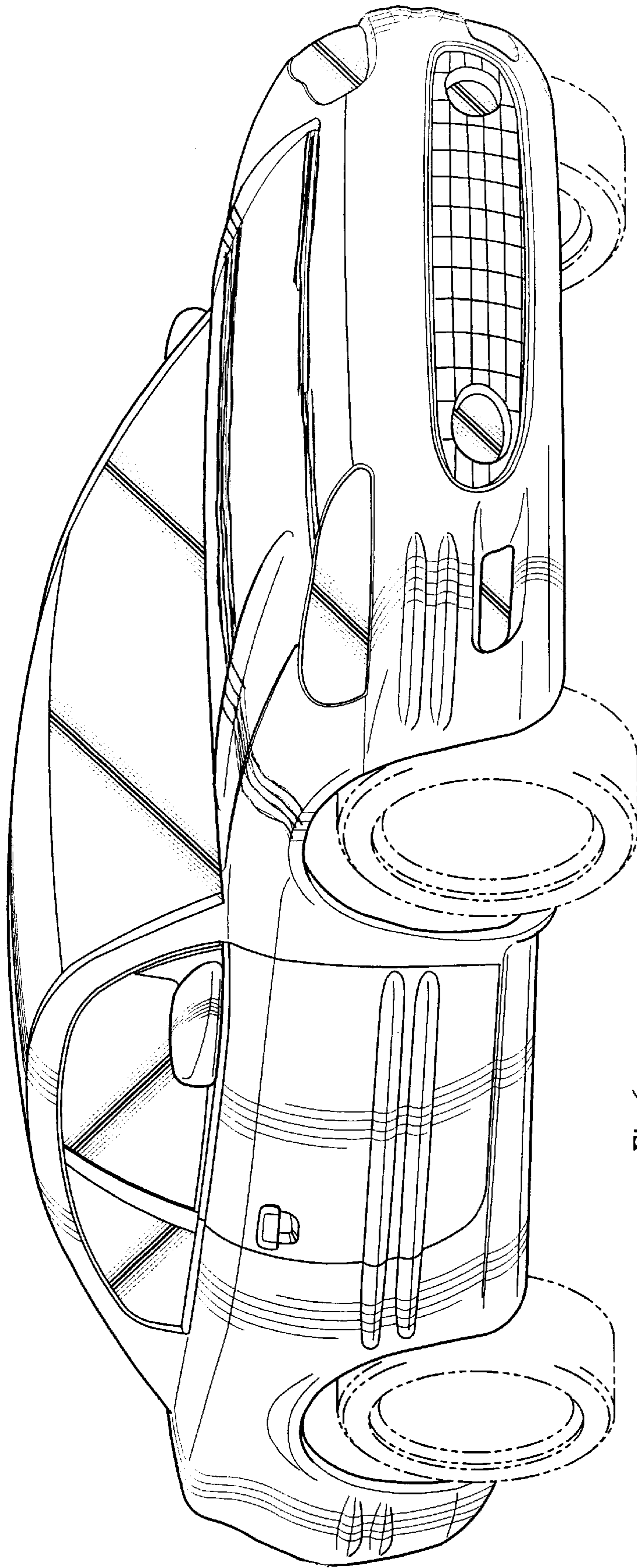

Fig-6

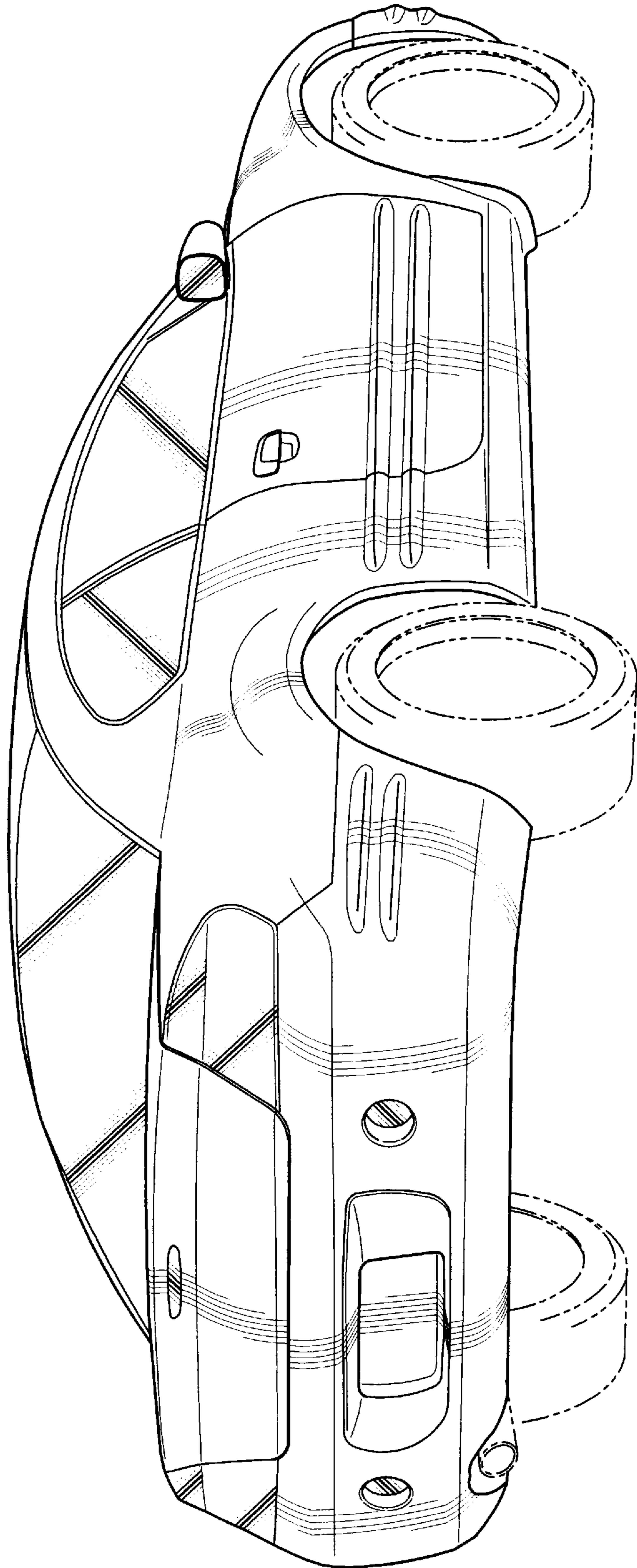

Fig-7

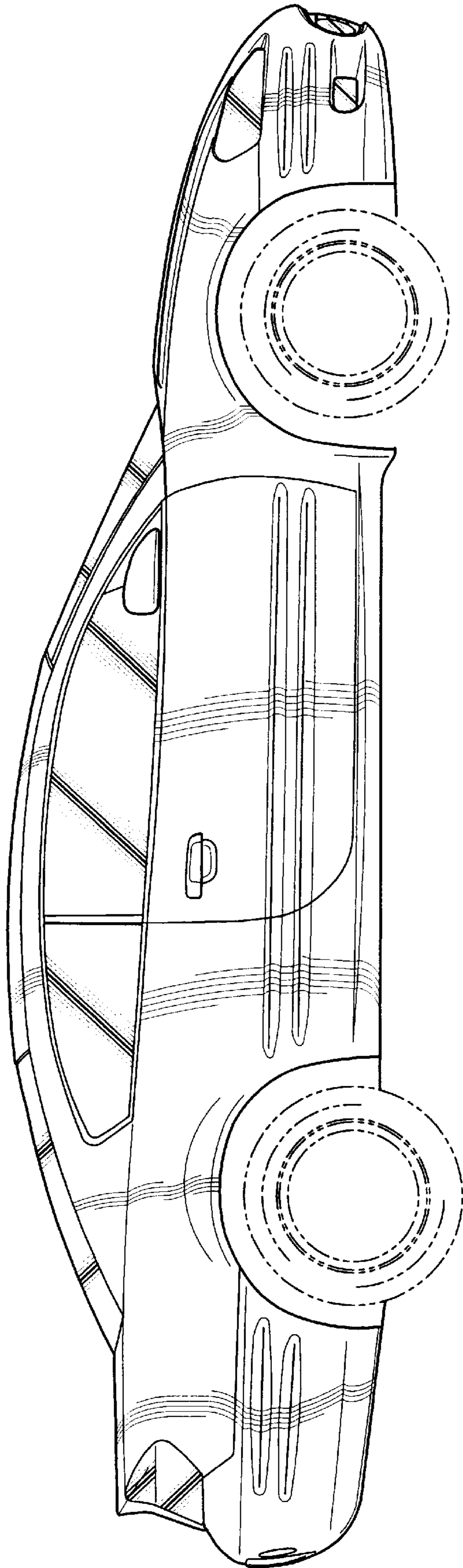

Fig-8

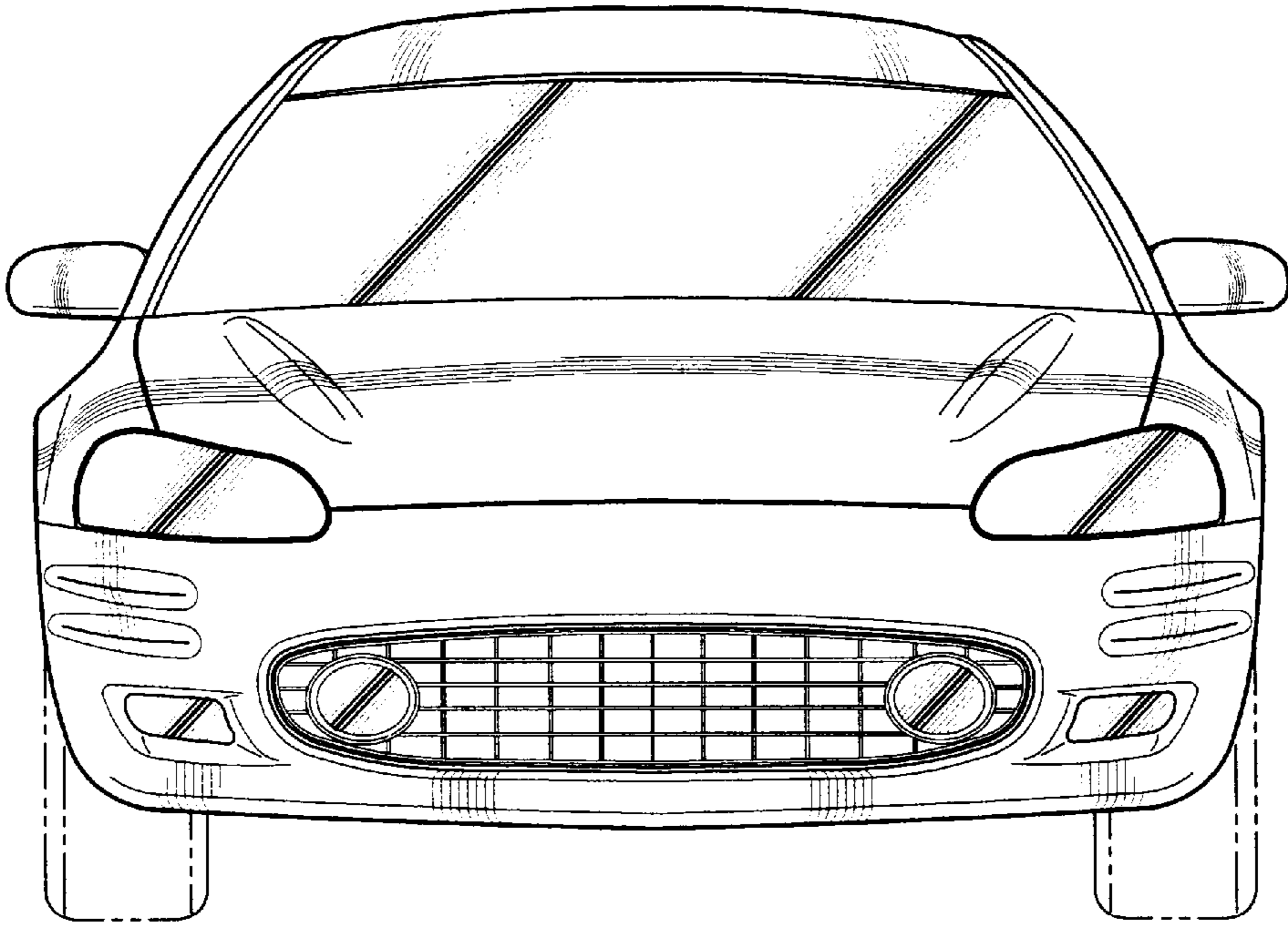

Fig-9

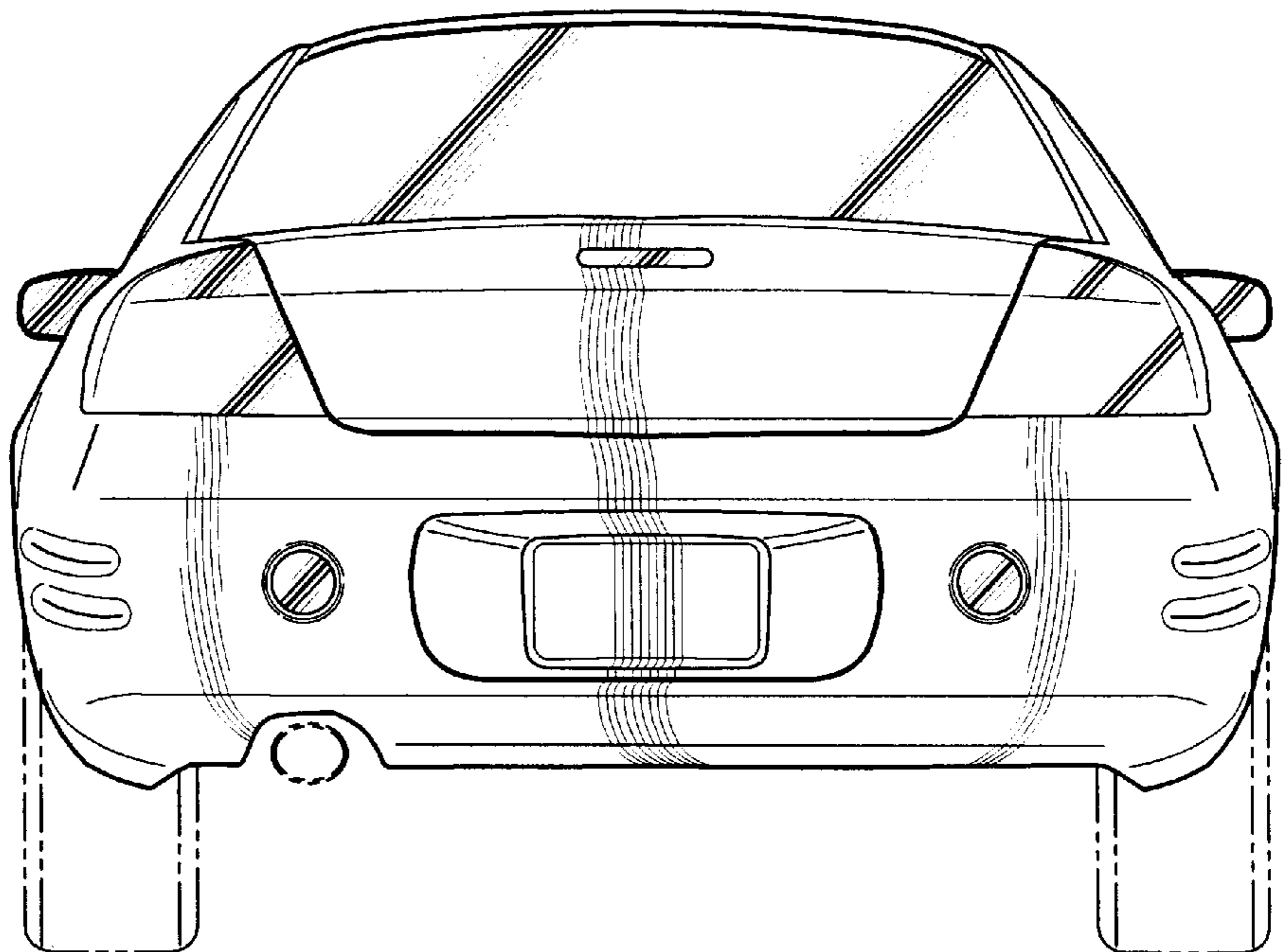

Fig-10