



US00D432051S

# United States Patent [19]

Lee et al.

[11] **Patent Number: Des. 432,051**

[45] **Date of Patent: \*\* Oct. 17, 2000**

[54] **VEHICLE BODY**

D. 419,489 1/2000 Sarro et al. .... D12/92  
D. 421,240 2/2000 Forbes-Robinson .... D12/92

[75] Inventors: **Bernard Giunhwang Lee**, Los Angeles; **Donald Mark Herner**, Placentia, both of Calif.

*Primary Examiner*—Melody N. Brown  
*Attorney, Agent, or Firm*—Banner & Witcoff, Ltd.

[73] Assignee: **Honda Giken Kogyo Kabushiki Kaisha**, Japan

[57] **CLAIM**

[\*\*] Term: **14 Years**

The ornamental design for a vehicle body, as shown and described.

[21] Appl. No.: **29/112,207**

**DESCRIPTION**

[22] Filed: **Oct. 14, 1999**

FIG. 1 is a front perspective view of a vehicle body showing our new design;

[51] **LOC (7) Cl.** ..... **12-16**

FIG. 2 is a rear perspective view thereof;

[52] **U.S. Cl.** ..... **D12/92**

FIG. 3 is a side elevational view thereof with the other side being a mirror image;

[58] **Field of Search** ..... D12/90-92, 88, D12/86; 296/185

FIG. 4 is a front elevational view thereof;

FIG. 5 is a rear elevational view thereof; and,

FIG. 6 is a top plan view thereof.

[56] **References Cited**

The broken line representations are for illustrative purposes only and form no part of the claimed design.

**U.S. PATENT DOCUMENTS**

D. 411,138 6/1999 Ramaciotti ..... D12/92  
D. 418,088 12/1999 Fioravanti ..... D12/92

**1 Claim, 4 Drawing Sheets**

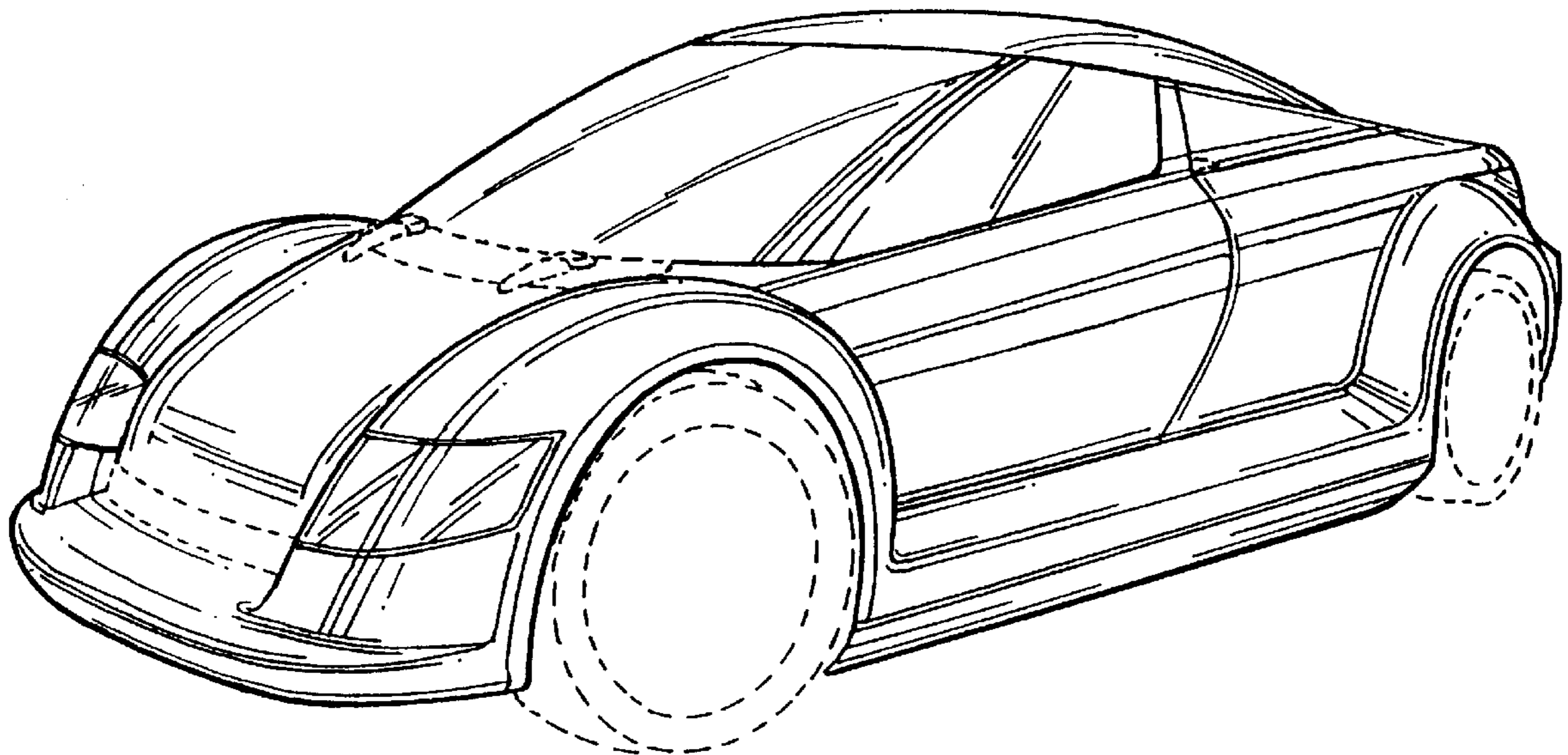

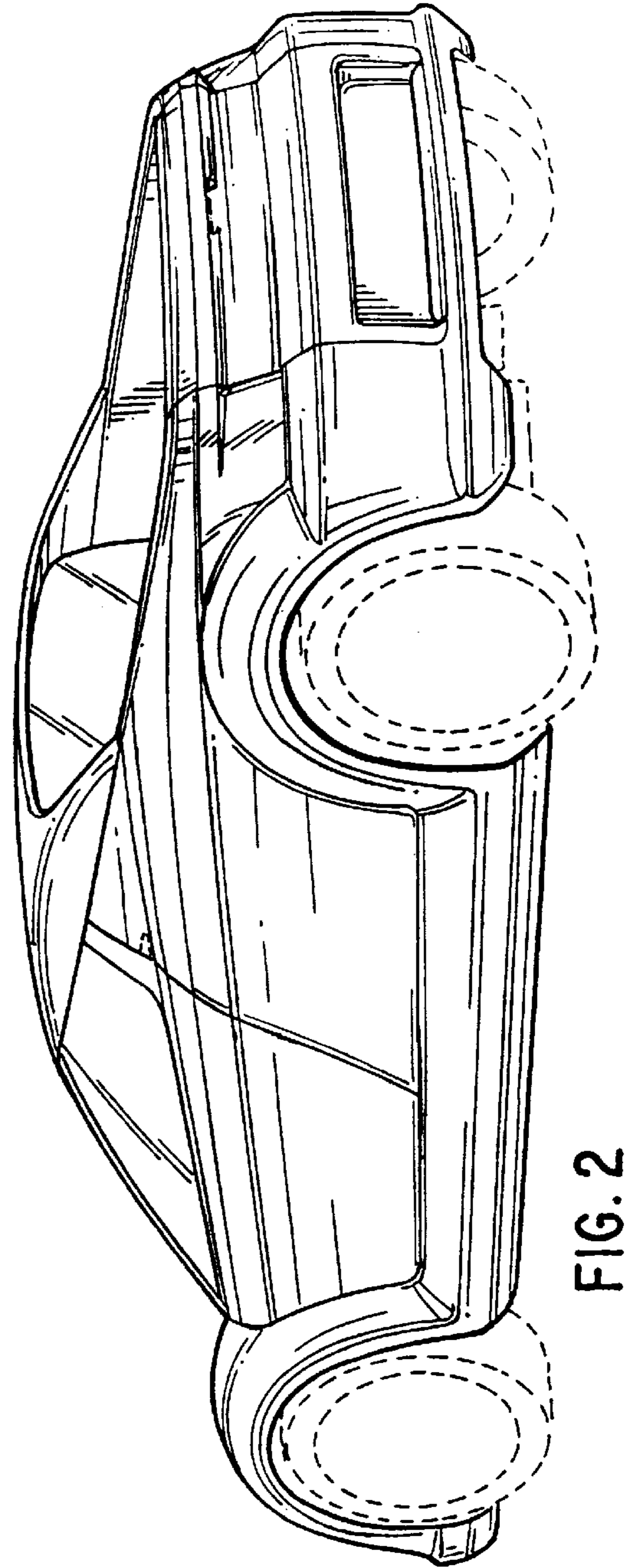
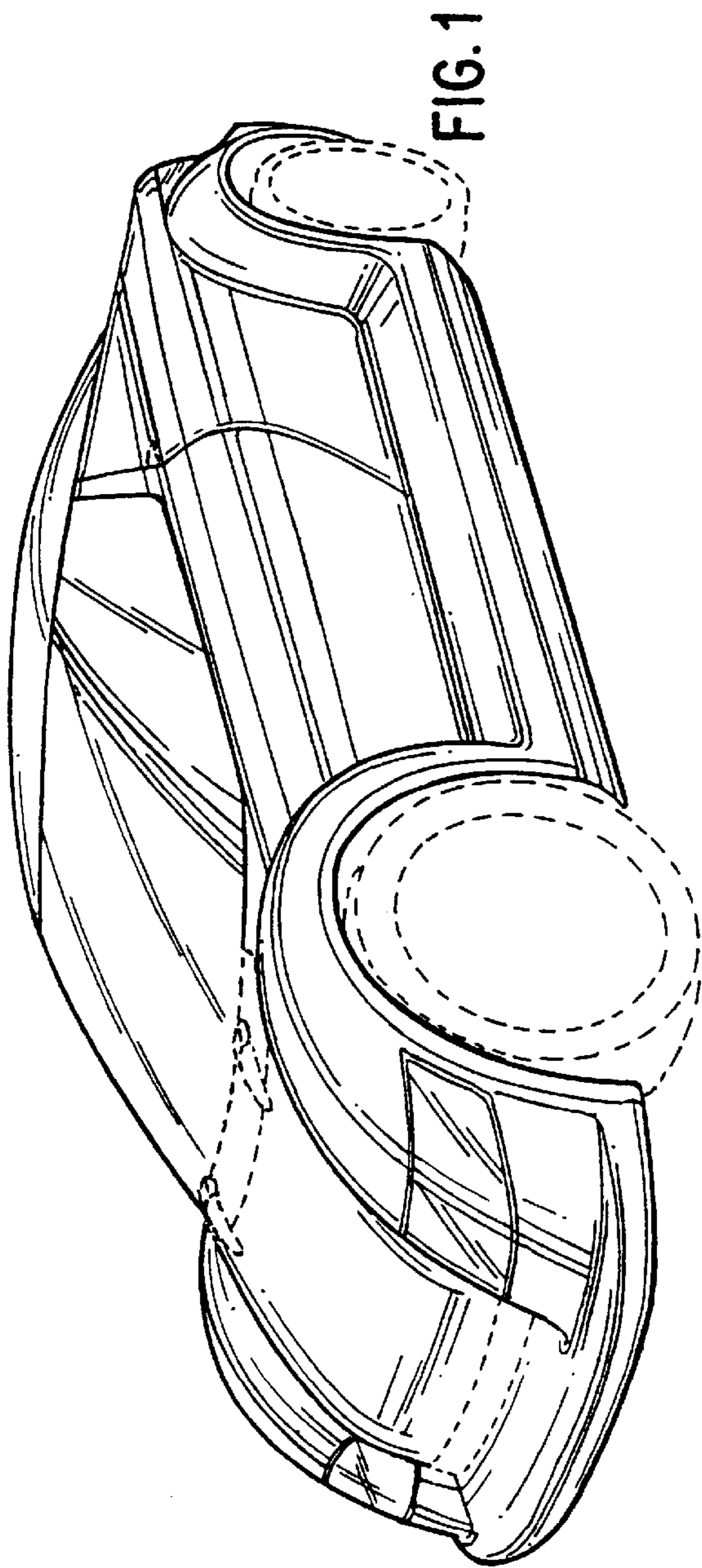

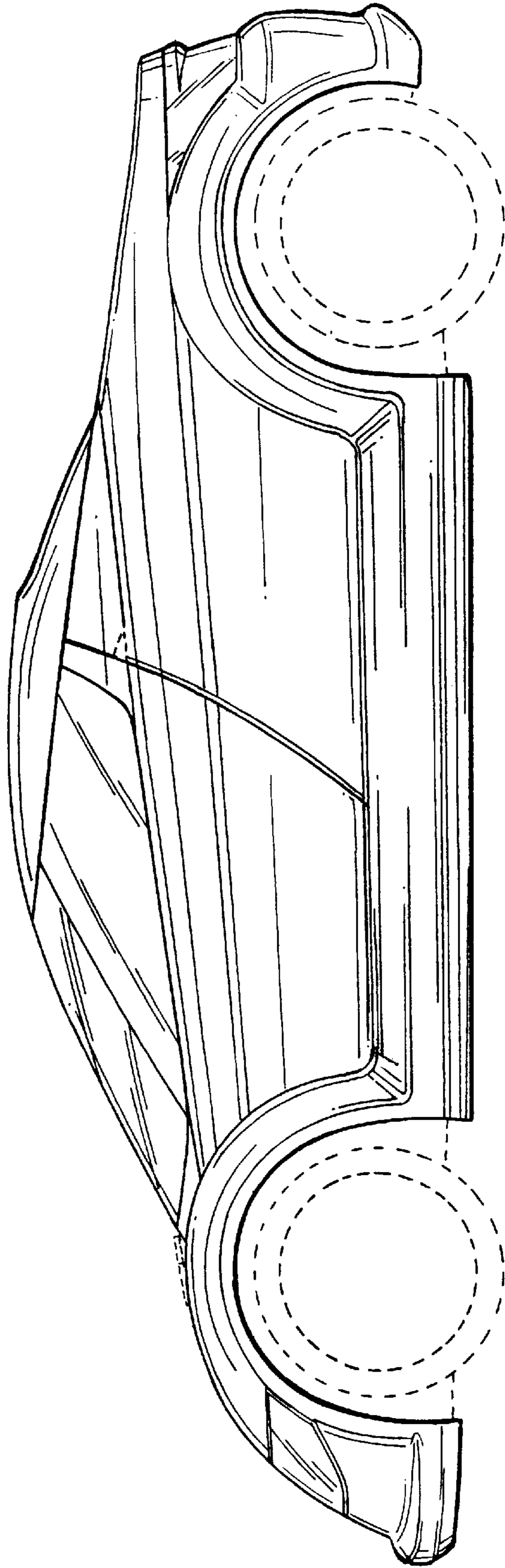

FIG. 3

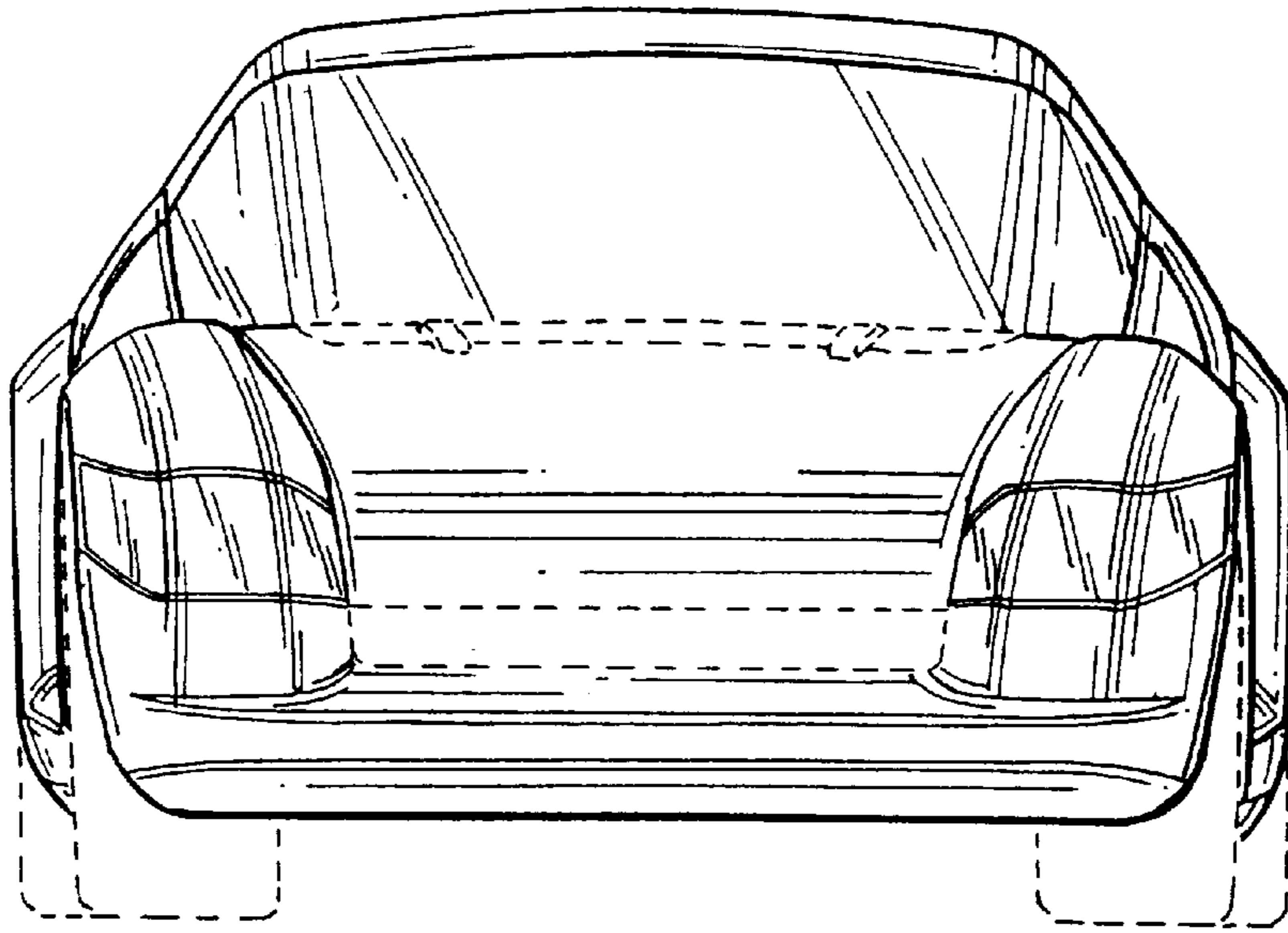

FIG. 4

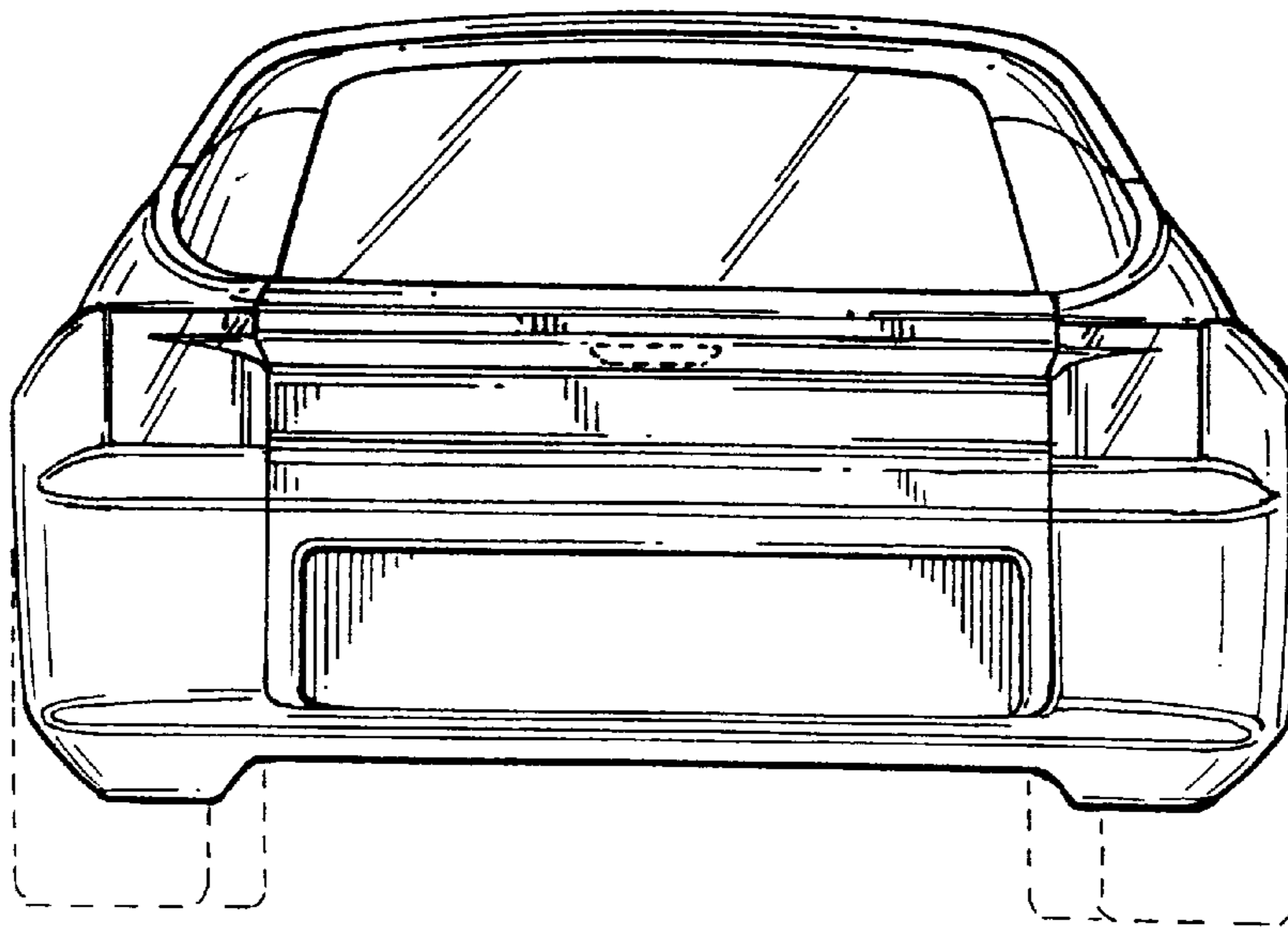

FIG. 5

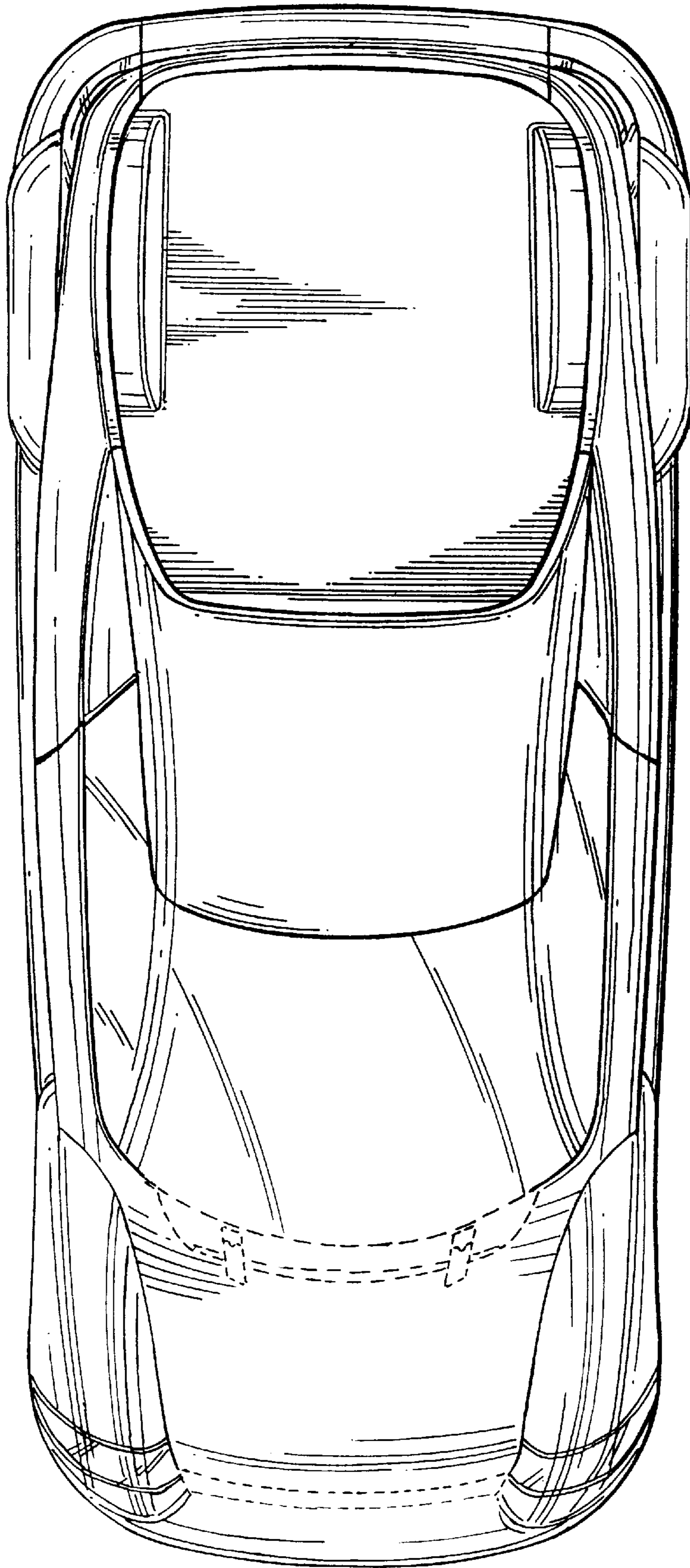

FIG. 6