



US00D431707S

United States Patent [19]

Few

[11] Patent Number: Des. 431,707

[45] Date of Patent: ** Oct. 3, 2000

[54] LEVELING JACK

[75] Inventor: Jeffrey P. Few, Elkhart, Ind.

[73] Assignee: Norco Industries, Inc., Elkhart, Ind.

[**] Term: 14 Years

[21] Appl. No.: 29/109,123

[22] Filed: Aug. 6, 1999

[51] LOC (7) Cl. 12-05

[52] U.S. Cl. D34/31

[58] Field of Search D34/31, 33, 28;
254/1, 8 R, 2 R, 11, 86, 124, 133, 134,
424, 419, 93; 280/763.1, 764.1, 762, 745.1,
746.1

[56] **References Cited**

U.S. PATENT DOCUMENTS

D. 349,801	8/1994	Few et al.	D34/31
D. 357,788	4/1995	Everett	D34/31
D. 364,259	11/1995	Garceau	D34/31
1,844,585	2/1932	Manley	254/8 R
2,404,577	7/1946	Jackson	254/8 R
2,575,160	11/1951	Clarke	254/11
2,575,485	11/1951	Bramble	254/86
3,967,814	7/1976	Leibungut	254/8 R
4,127,255	11/1978	Wooding	254/133
4,277,048	7/1981	Okuda	254/8 R

4,690,378	9/1987	Jarman et al.	254/8 R
5,065,983	11/1991	Slay	254/8 R
5,190,265	3/1993	Barry et al.	254/134
5,199,687	4/1993	Maurer	254/124

Primary Examiner—Susan J. Lucas
Assistant Examiner—Cynthia E Ramirez
Attorney, Agent, or Firm—Oldham & Oldham Co., L.P.A.

[57] **CLAIM**

The ornamental design for a leveling jack, as shown and described.

DESCRIPTION

FIG. 1 is a perspective view of a new design for a vehicle leveling jack;
FIG. 2 is a top view of the vehicle leveling jack in a retracted position;
FIG. 3 is a front elevational view of the vehicle leveling jack in a retracted position;
FIG. 4 is an elevational end view of the vehicle leveling jack in a retracted position;
FIG. 5 is a front elevational view of the vehicle leveling jack in an extended position;
FIG. 6 is an elevational end view of the vehicle leveling jack in an extended position; and,
FIG. 7 is a bottom view of the vehicle leveling jack in an extended position.

1 Claim, 5 Drawing Sheets

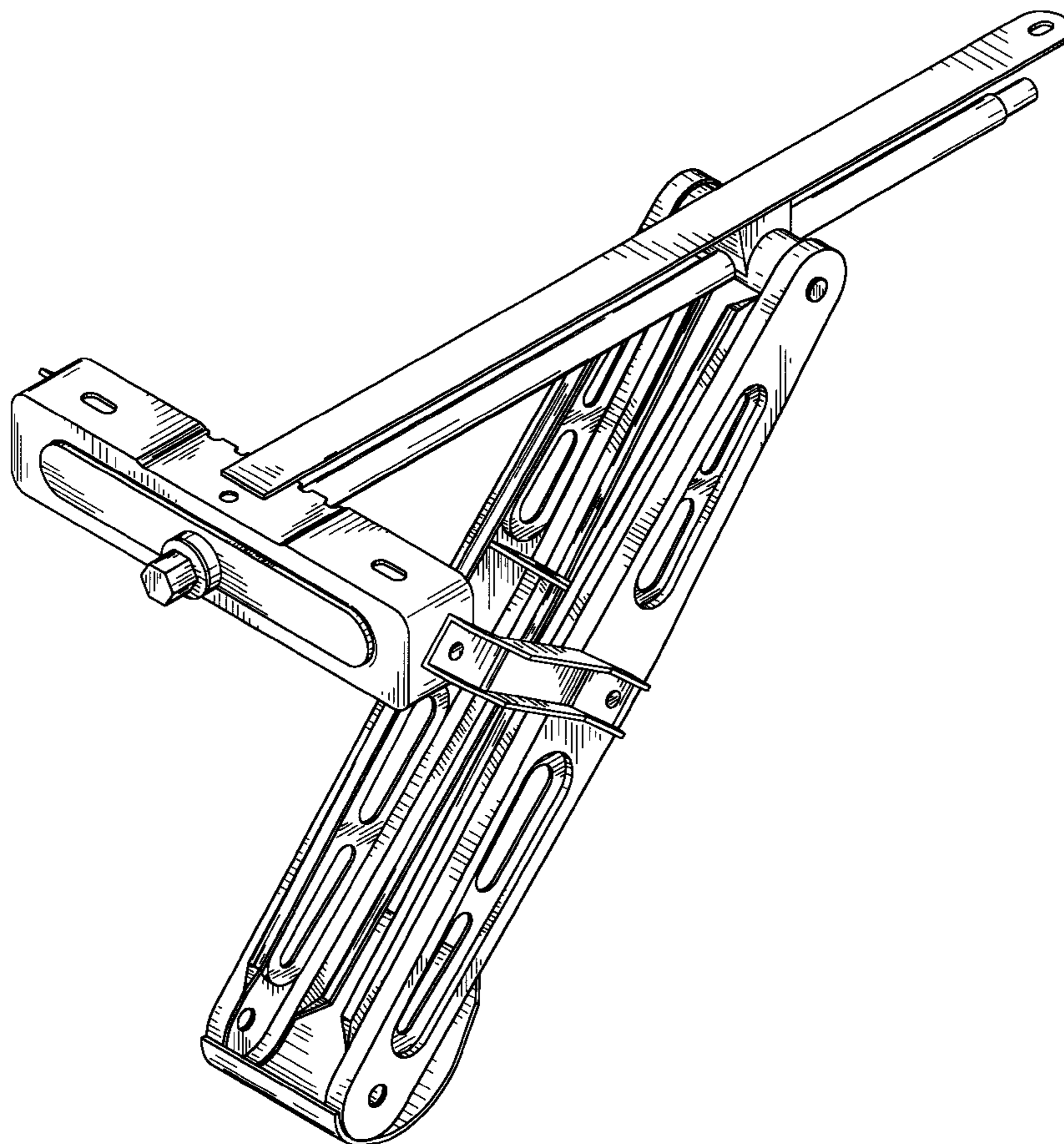

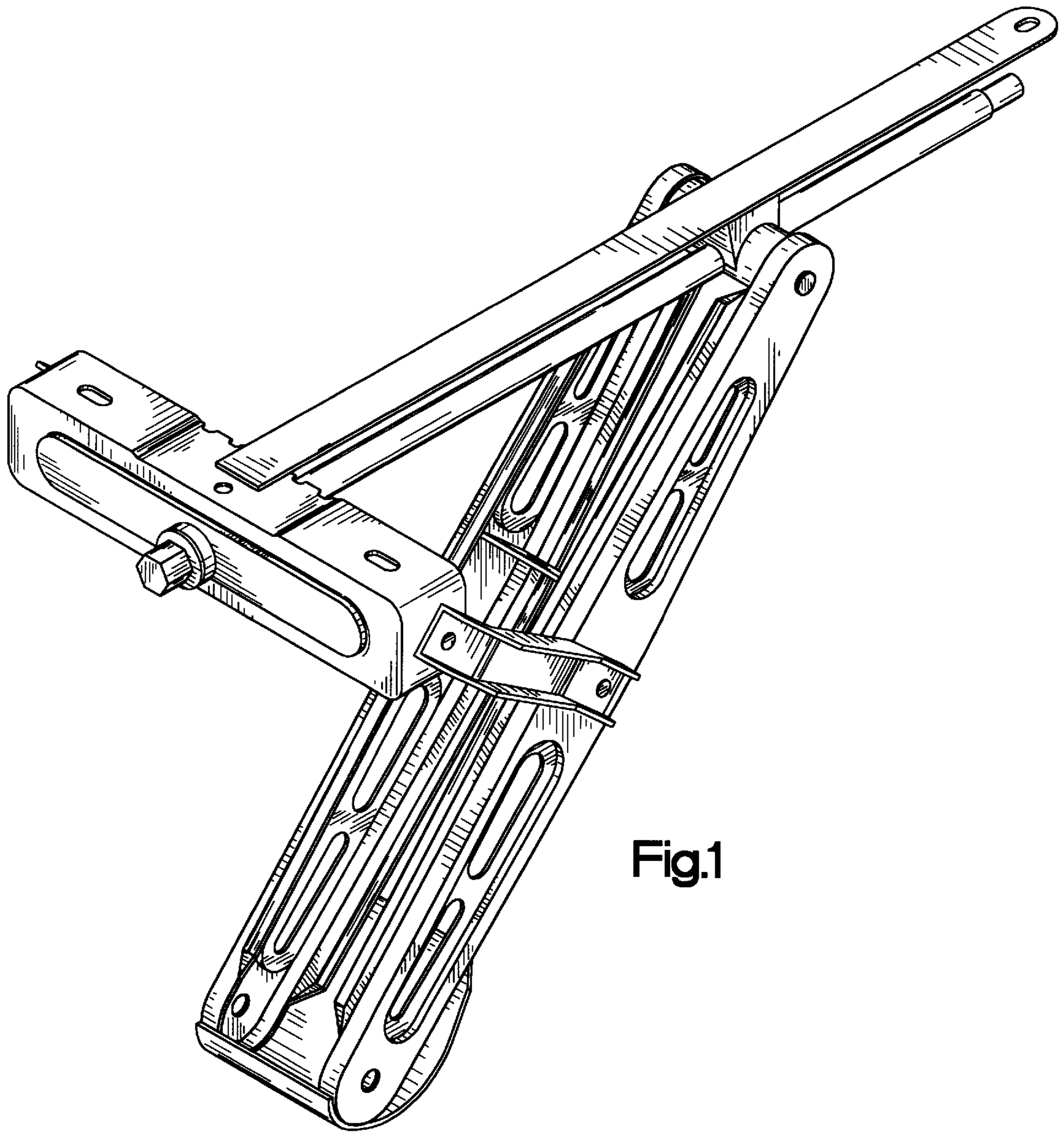

Fig.1

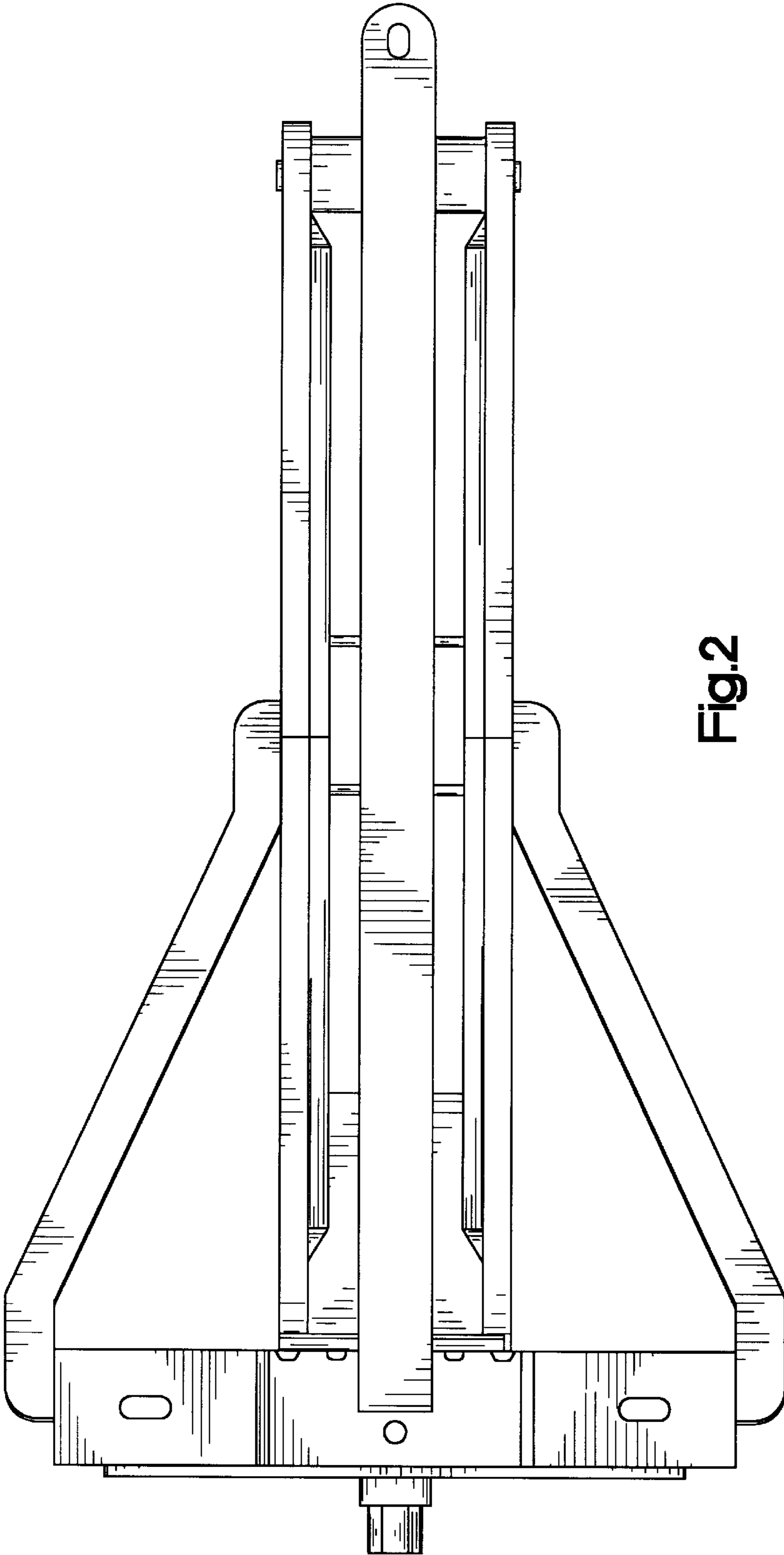

Fig.2

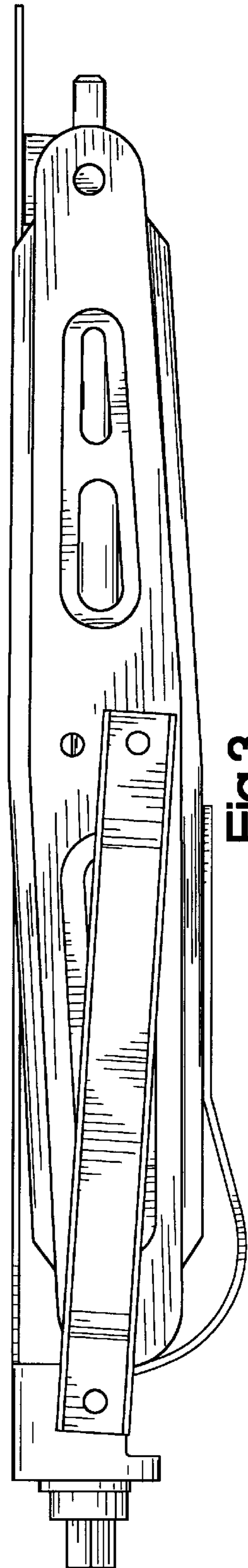

Fig.3

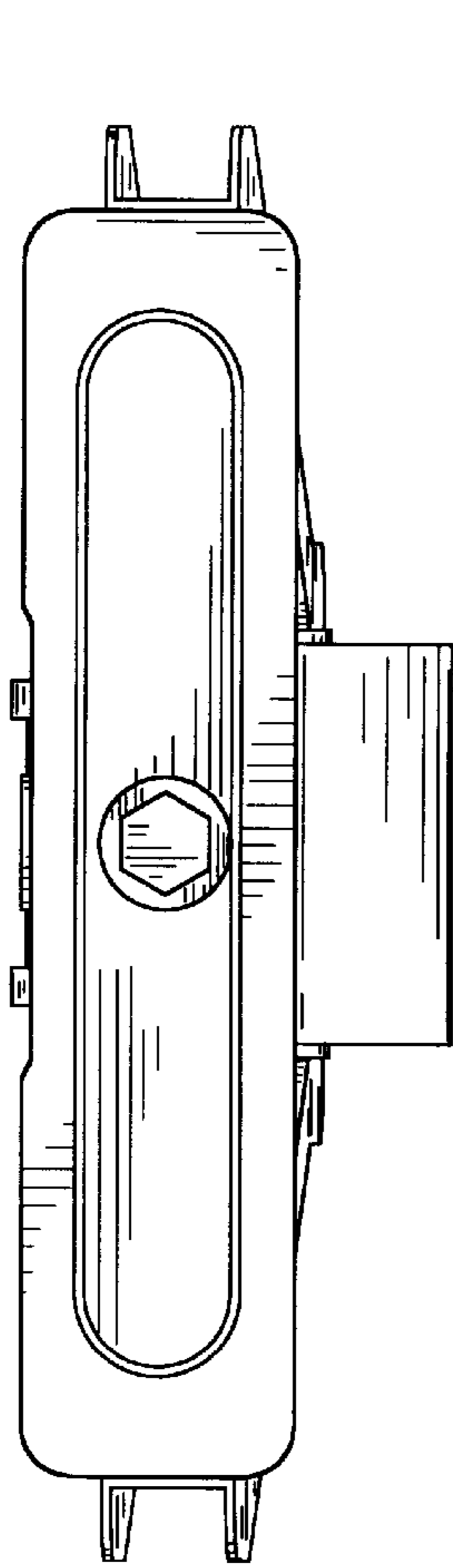

Fig.4

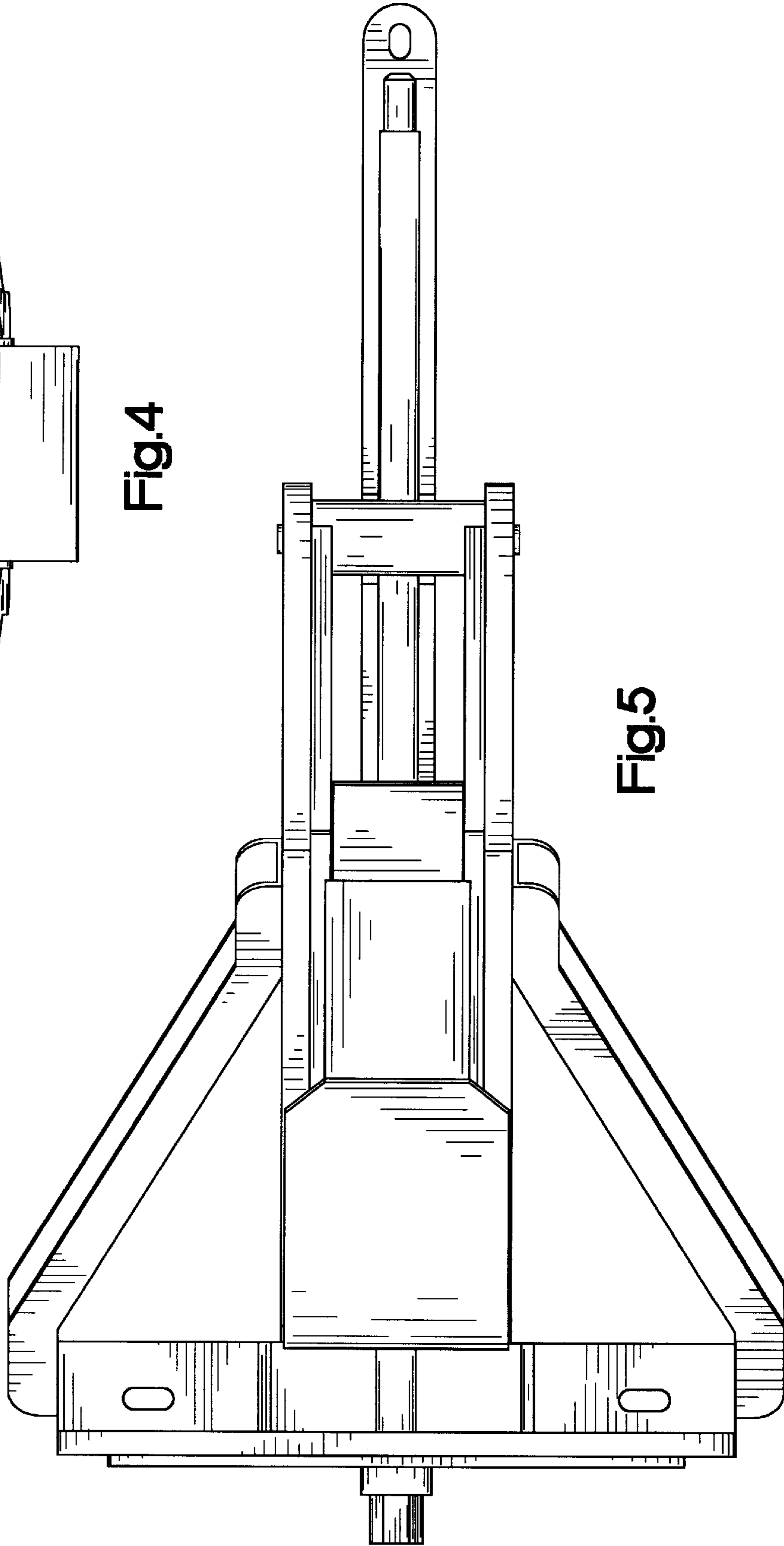
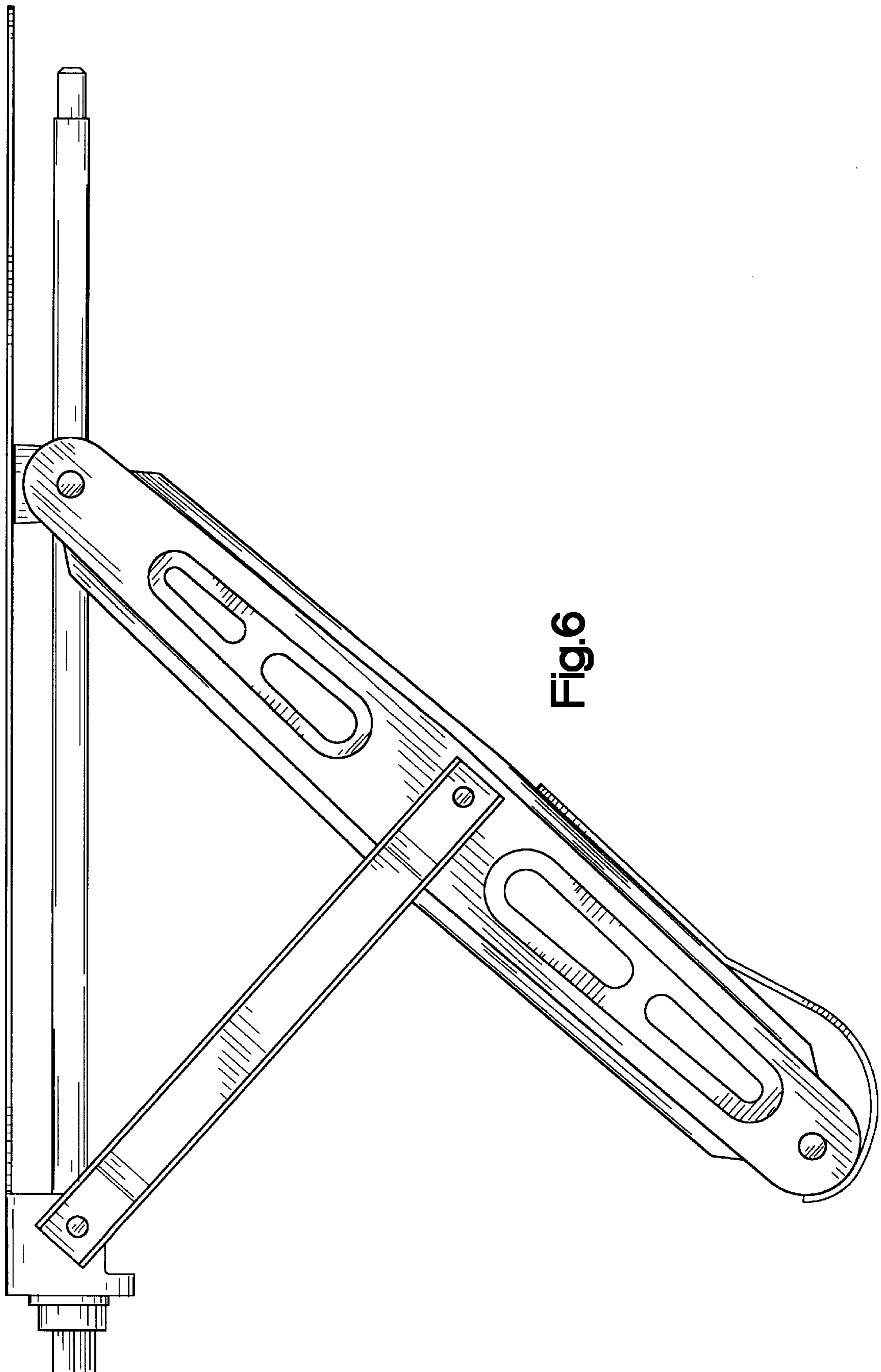

Fig.5



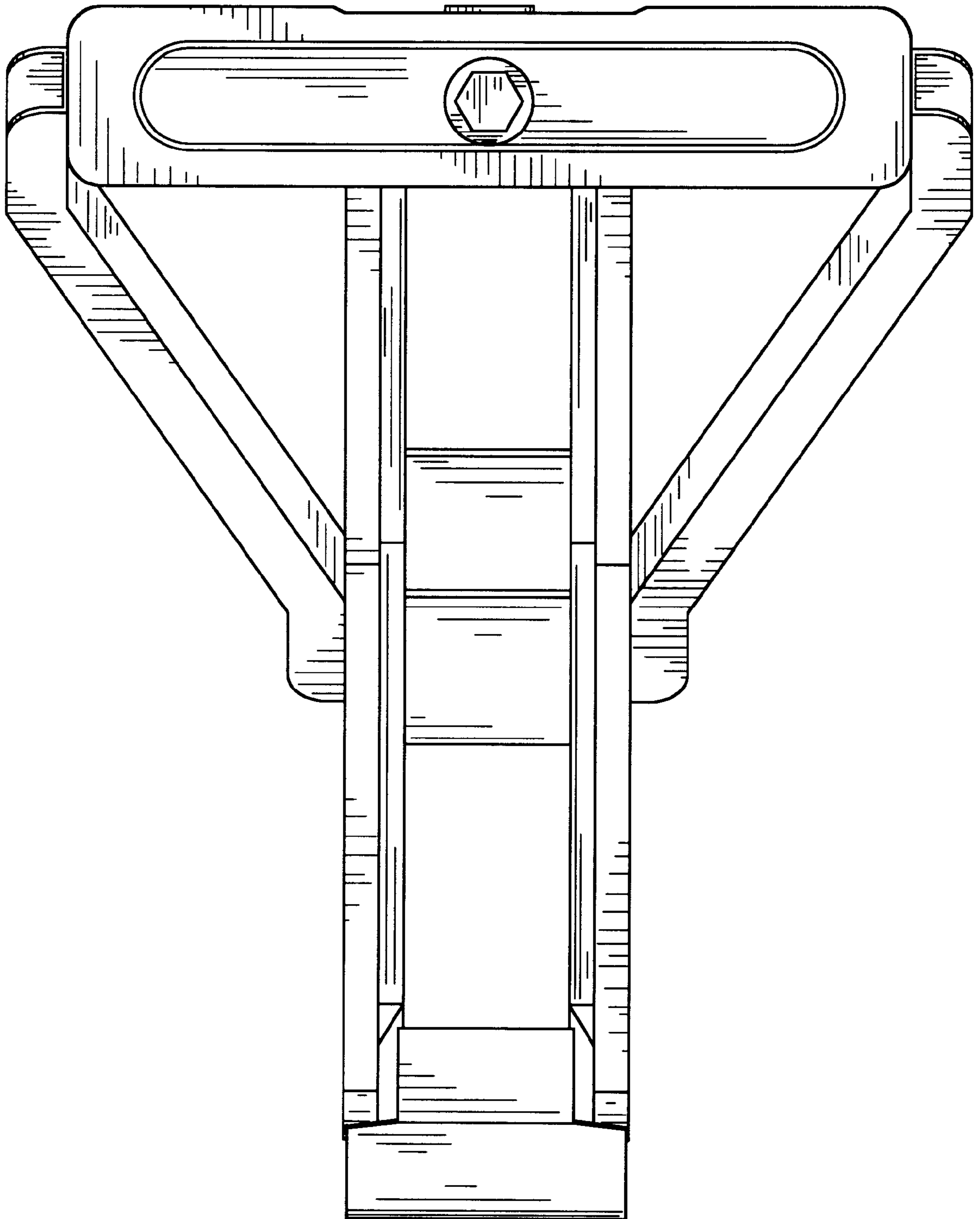

Fig.7