



US00D431556S

# United States Patent [19]

Beaumont et al.

[11] Patent Number: **Des. 431,556**

[45] Date of Patent: **\*\* Oct. 3, 2000**

[54] ENVIRONMENTAL ENCLOSURE FOR HOUSING CELLULAR RF EQUIPMENT

[75] Inventors: **Thomas Glenn Beaumont**, Bedford; **Dwayne Allan Daggs**, Burleson; **Roger Paul Gandee**, Azle, all of Tex.

[73] Assignee: **Motorola, Inc.**, Schaumburg, Ill.

[\*\*] Term: **14 Years**

[21] Appl. No.: **29/112,733**

[22] Filed: **Oct. 22, 1999**

[51] LOC (7) Cl. .... **14-03**

[52] U.S. Cl. .... **D14/240; D13/184**

[58] Field of Search ..... D14/137, 140, D14/142, 141, 107, 240, 242, 348-353, 356-358; 379/419, 420, 428, 440; 455/550-575, 90, 16, 347-349; D13/184, 162.1, 147, 152; 361/804, 724, 752, 686; D23/335

### [56] References Cited

#### U.S. PATENT DOCUMENTS

D. 235,653	7/1975	Bozich	.....	D13/184
D. 263,216	3/1982	Maher	.....	D13/184
D. 278,058	3/1985	Larson	.....	D14/184
D. 282,541	2/1986	Yasuda	.....	D14/140
D. 303,664	9/1989	Harden et al.	.....	D14/140
D. 314,770	2/1991	Desbarats	.....	D14/240

D. 326,098	5/1992	Alden et al.	.....	D14/240
D. 343,230	1/1994	Lim	.....	D23/335
D. 354,480	1/1995	Agata et al.	.....	D14/107
D. 356,302	3/1995	Studebaker et al.	.....	D14/107
D. 367,652	3/1996	Beaumont	.....	D14/149
D. 369,170	4/1996	Beaumont et al.	.....	D14/240
D. 373,362	9/1996	Kuroiwa et al.	.....	D14/240
D. 390,199	2/1998	Jackson et al.	.....	D13/184
D. 401,940	12/1998	Flores et al.	.....	D14/240
D. 411,185	6/1999	Isshiki	.....	D14/107
D. 422,977	4/2000	Hirose et al.	.....	D14/107

Primary Examiner—Jeffrey Asch  
Attorney, Agent, or Firm—Mario J. Donato, Jr.

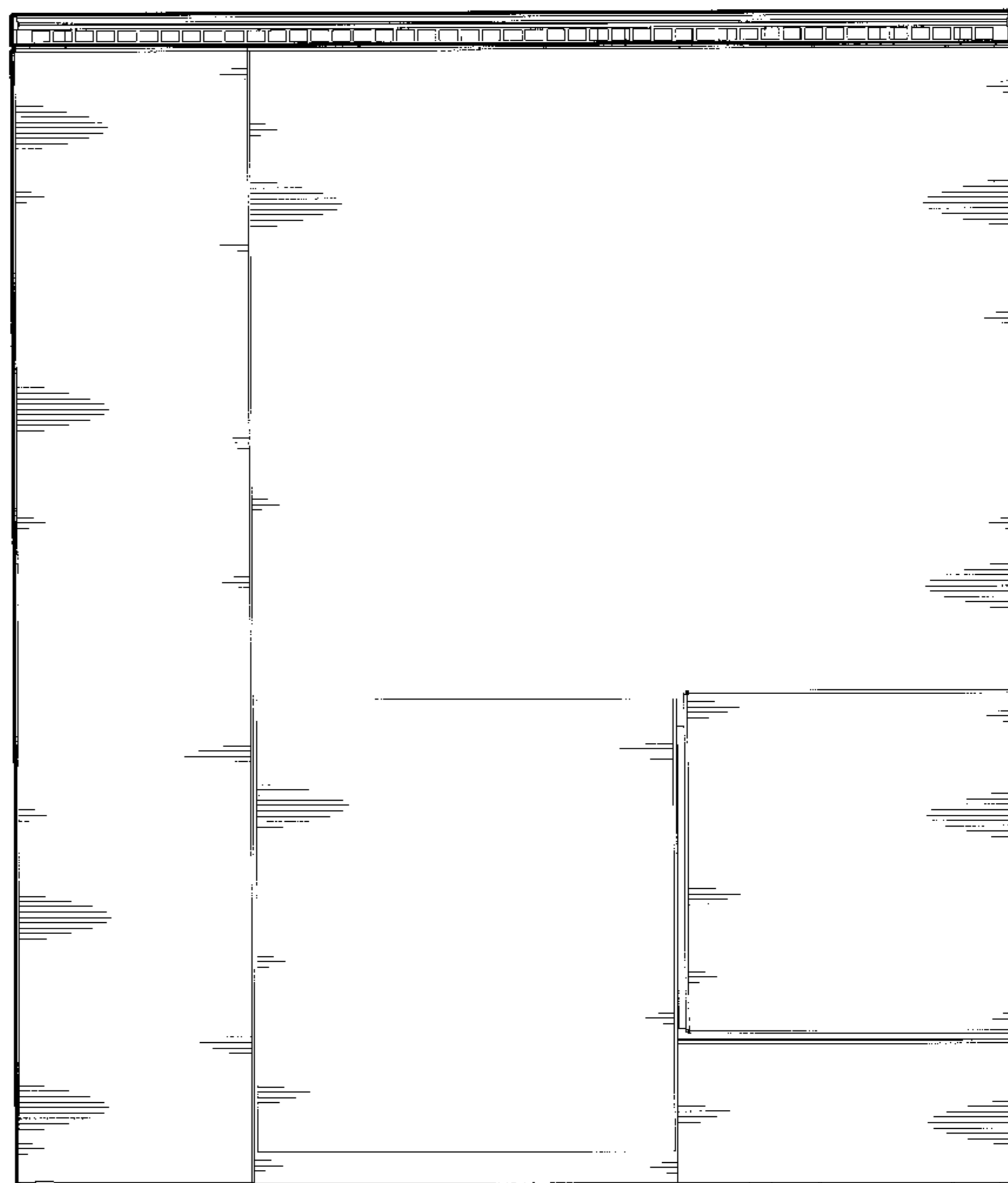
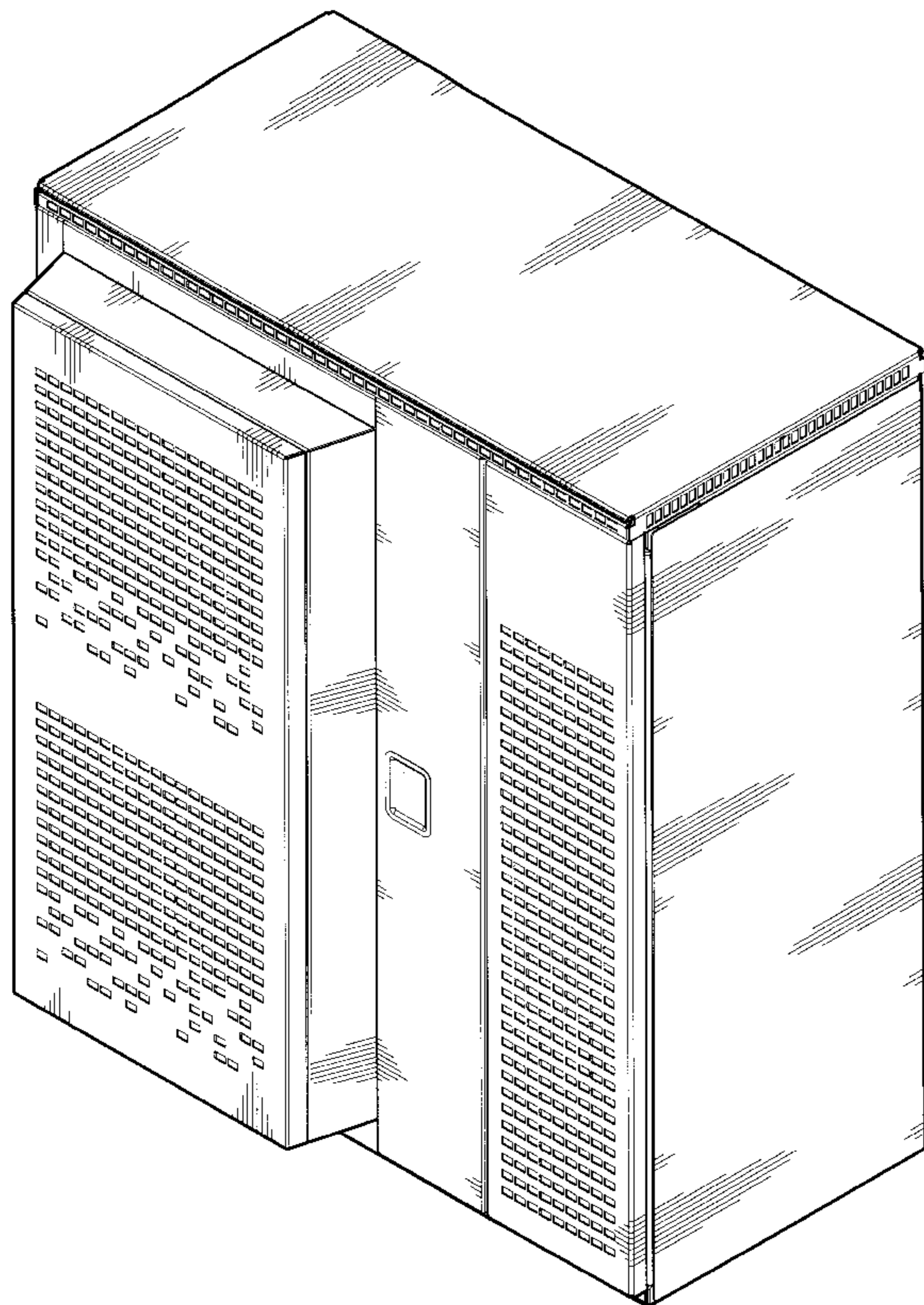
### [57] CLAIM

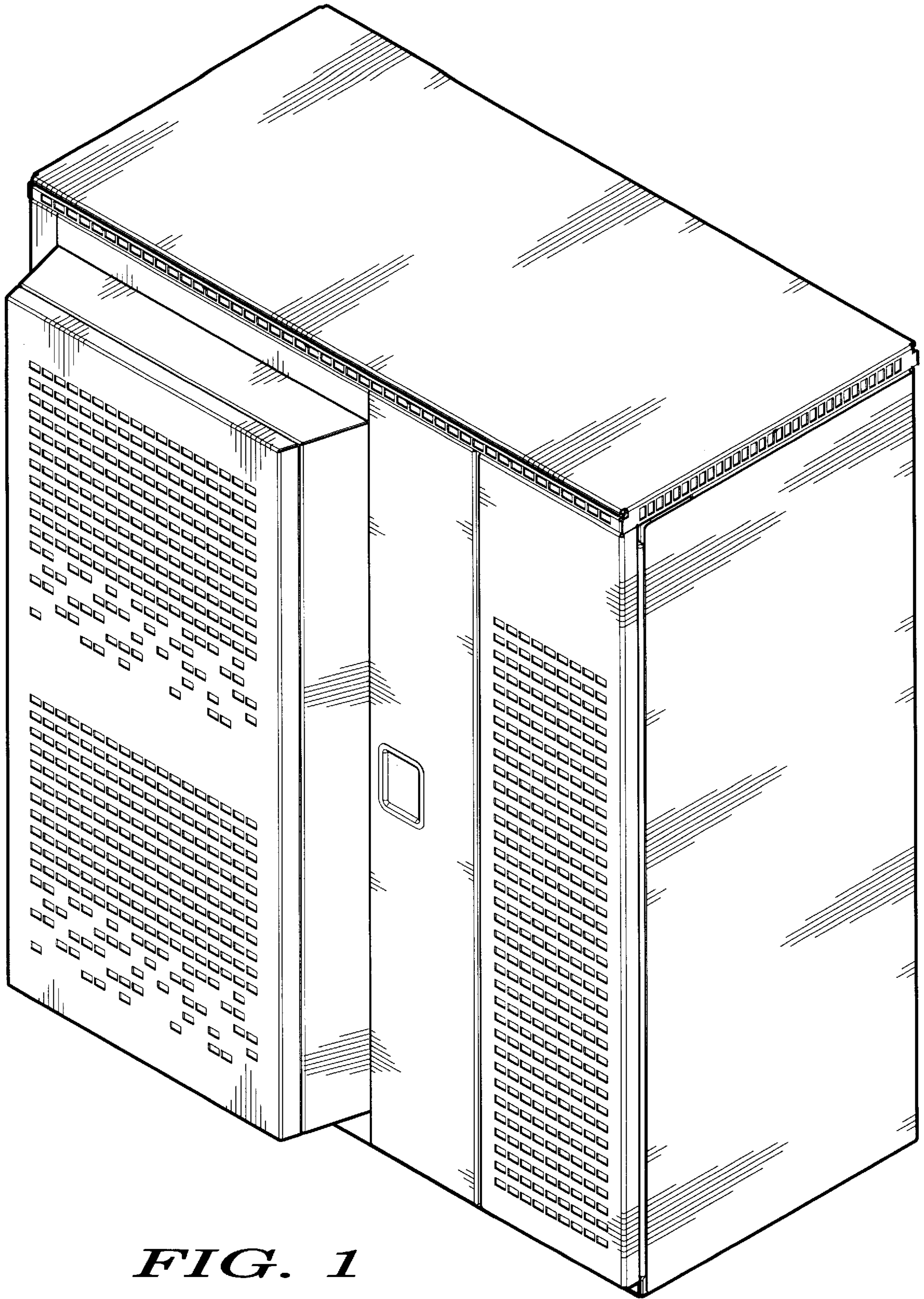
The ornamental design for an environmental enclosure for housing cellular RF equipment, as shown and described.

### DESCRIPTION

FIG. 1 is a rear view in perspective of an environmental enclosure for housing cellular RF equipment showing our new design;  
FIG. 2 is a rear elevational view thereof;  
FIG. 3 is a front elevational view thereof;  
FIG. 4 is a right side view thereof;  
FIG. 5 is a left side view thereof;  
FIG. 6 is a bottom plan view thereof; and,  
FIG. 7 is a top plan view thereof.

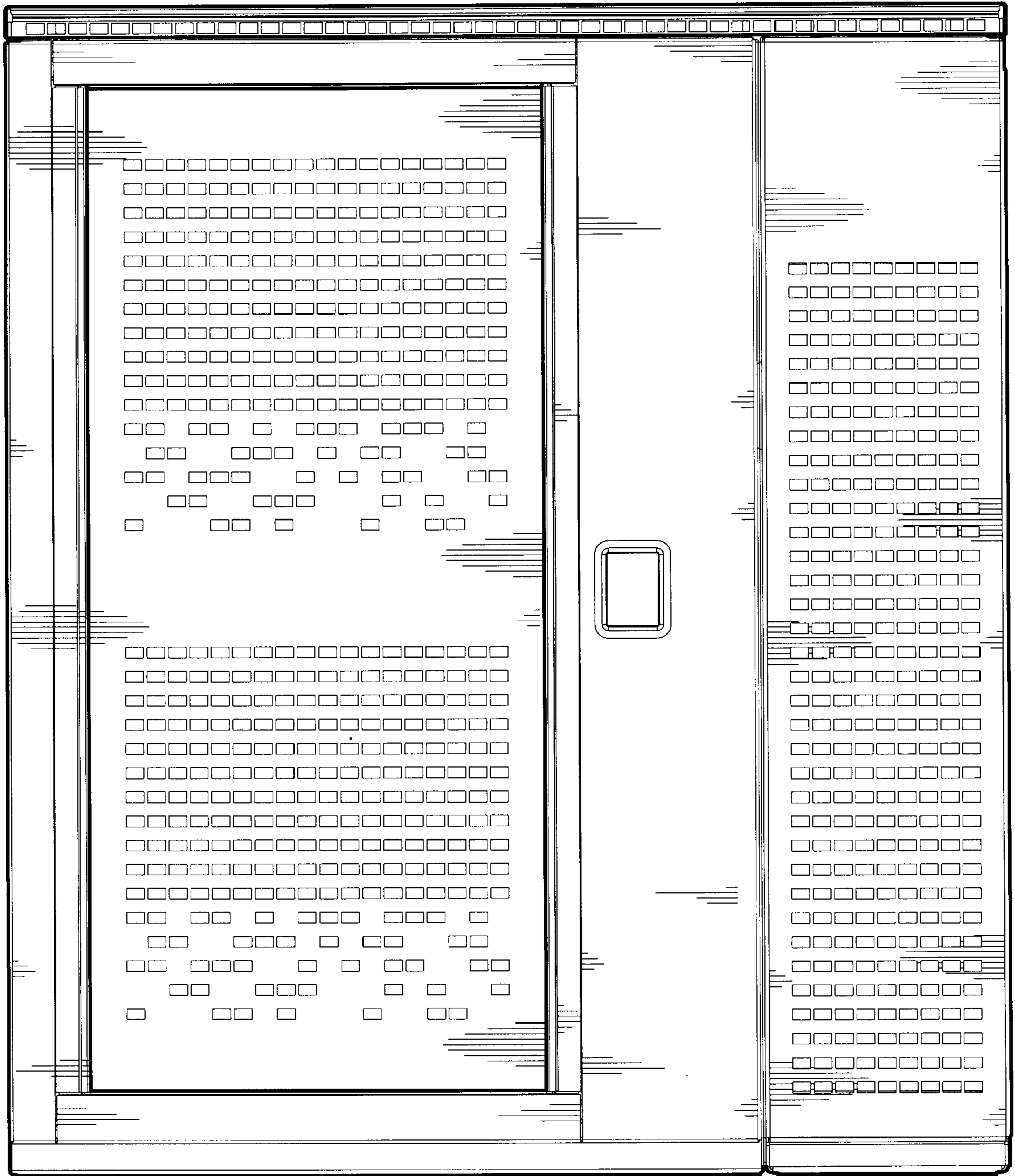
**1 Claim, 6 Drawing Sheets**



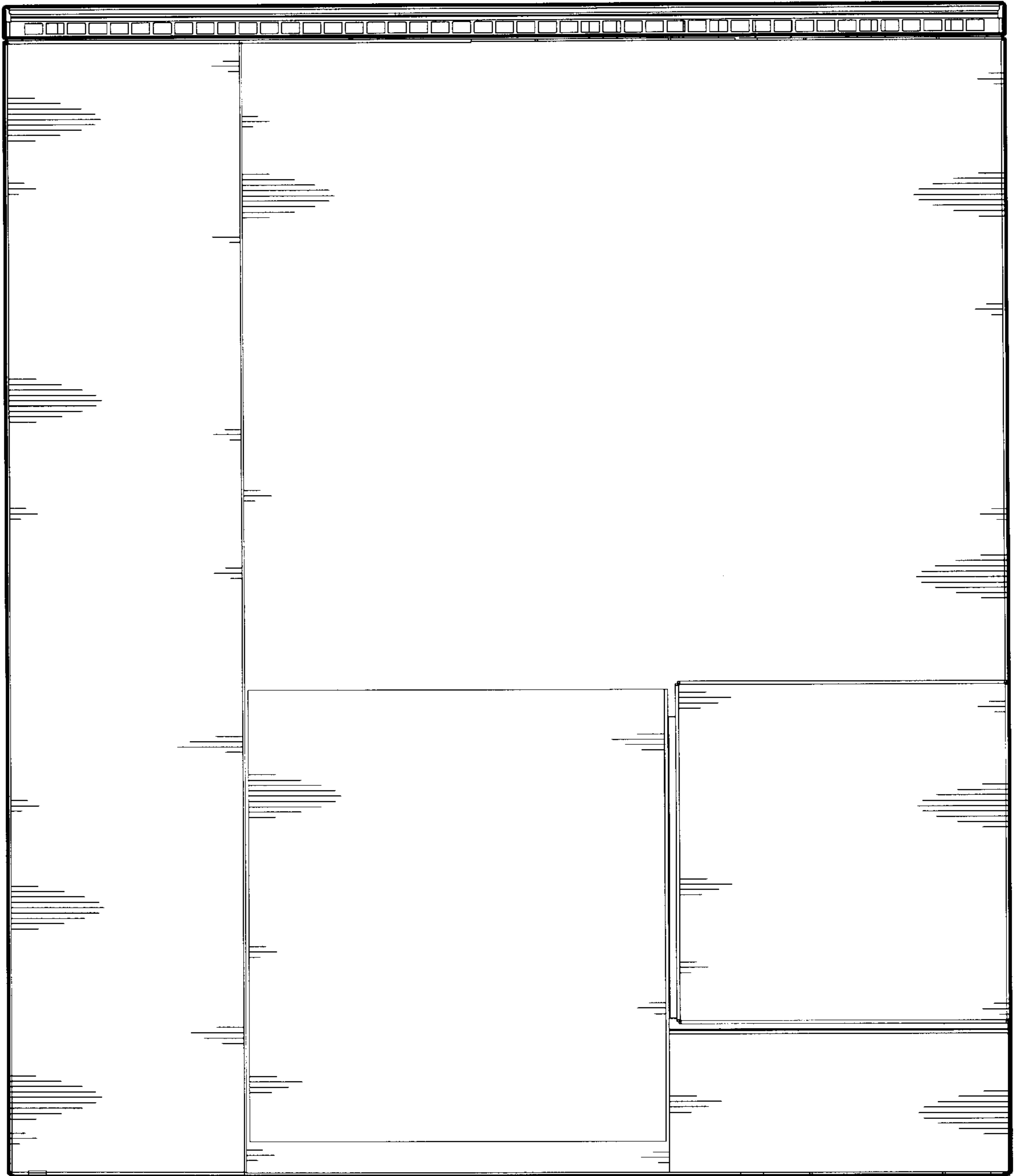


**FIG. 1**

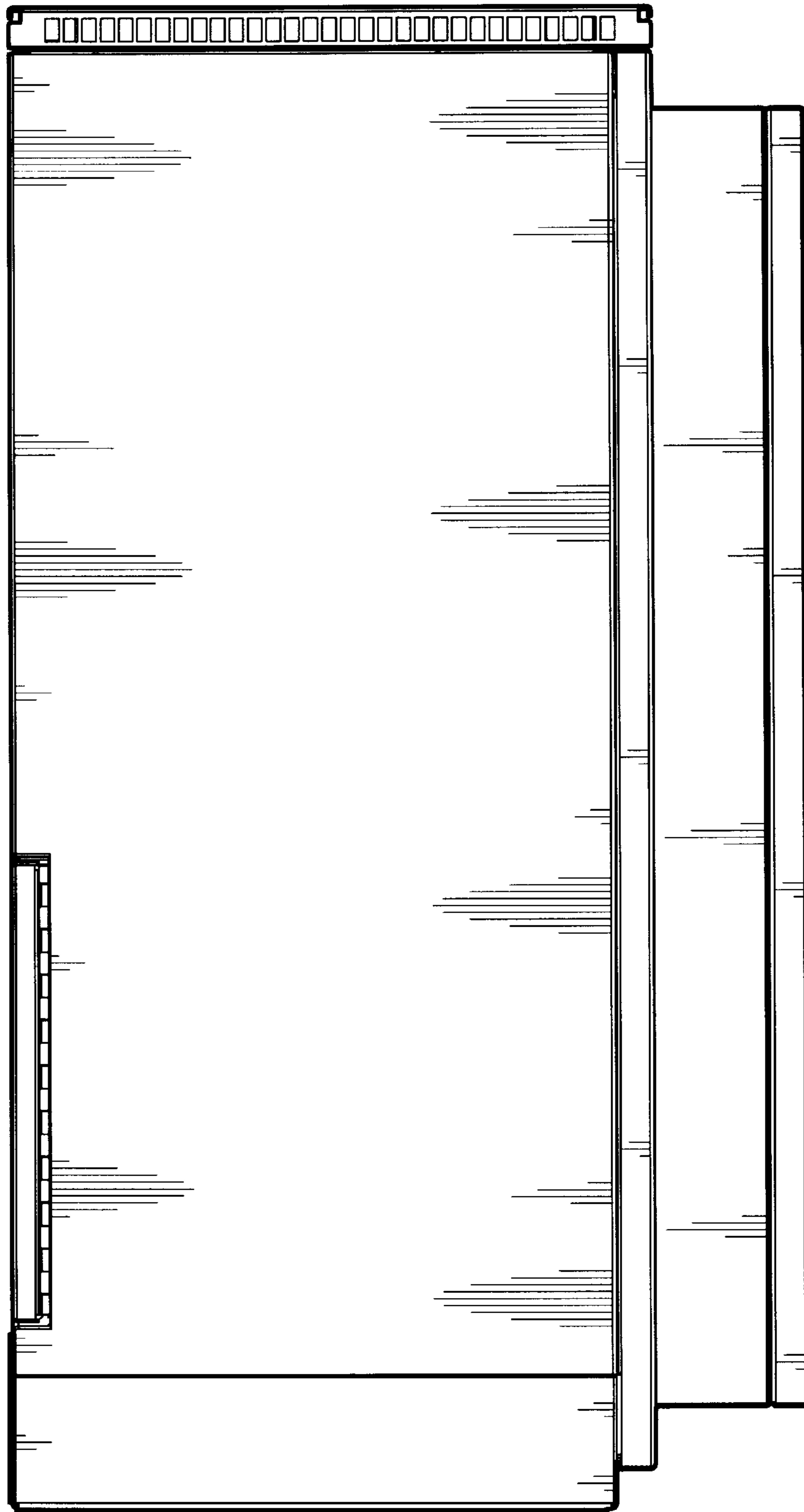




**FIG. 2**



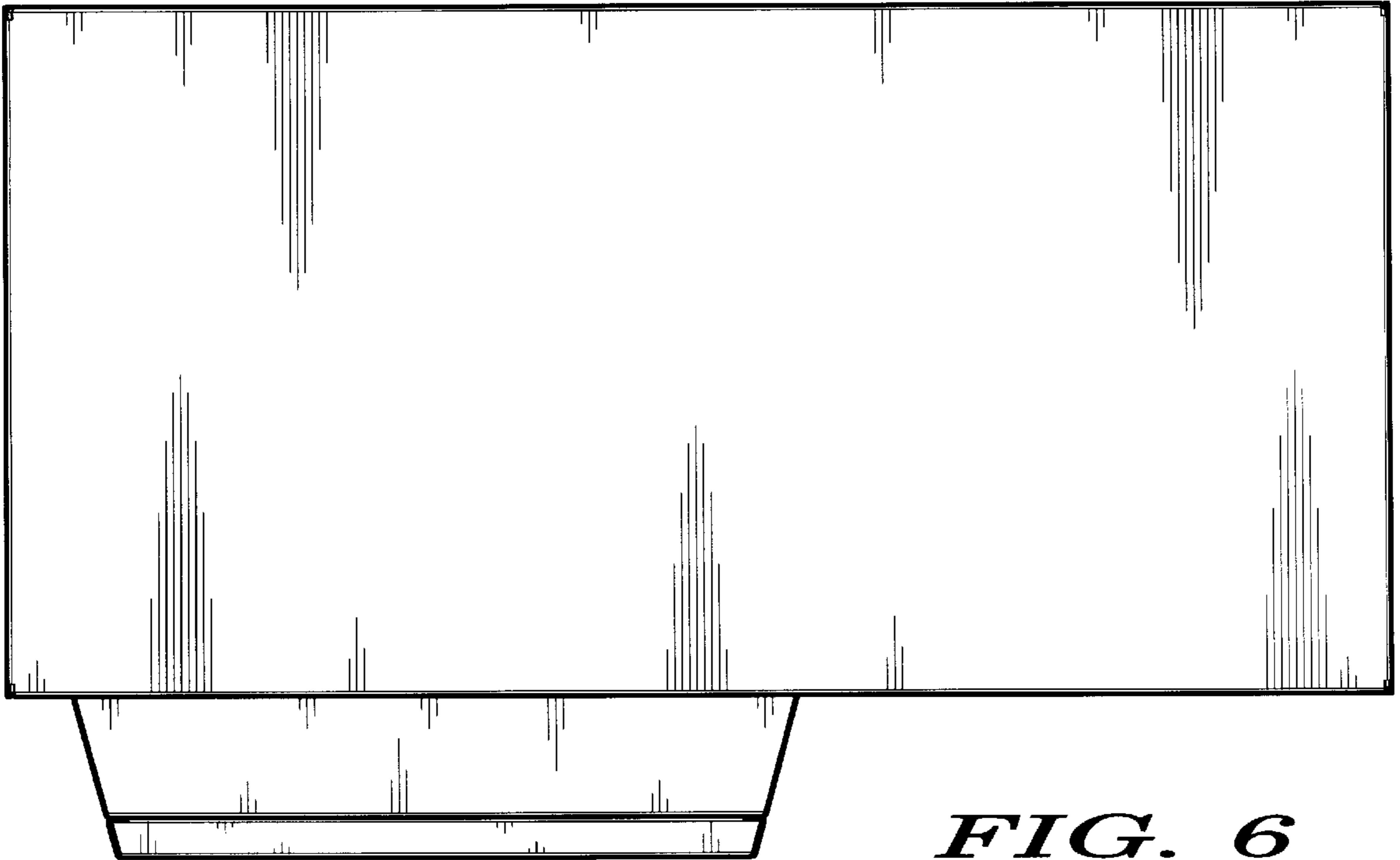
***FIG. 3***



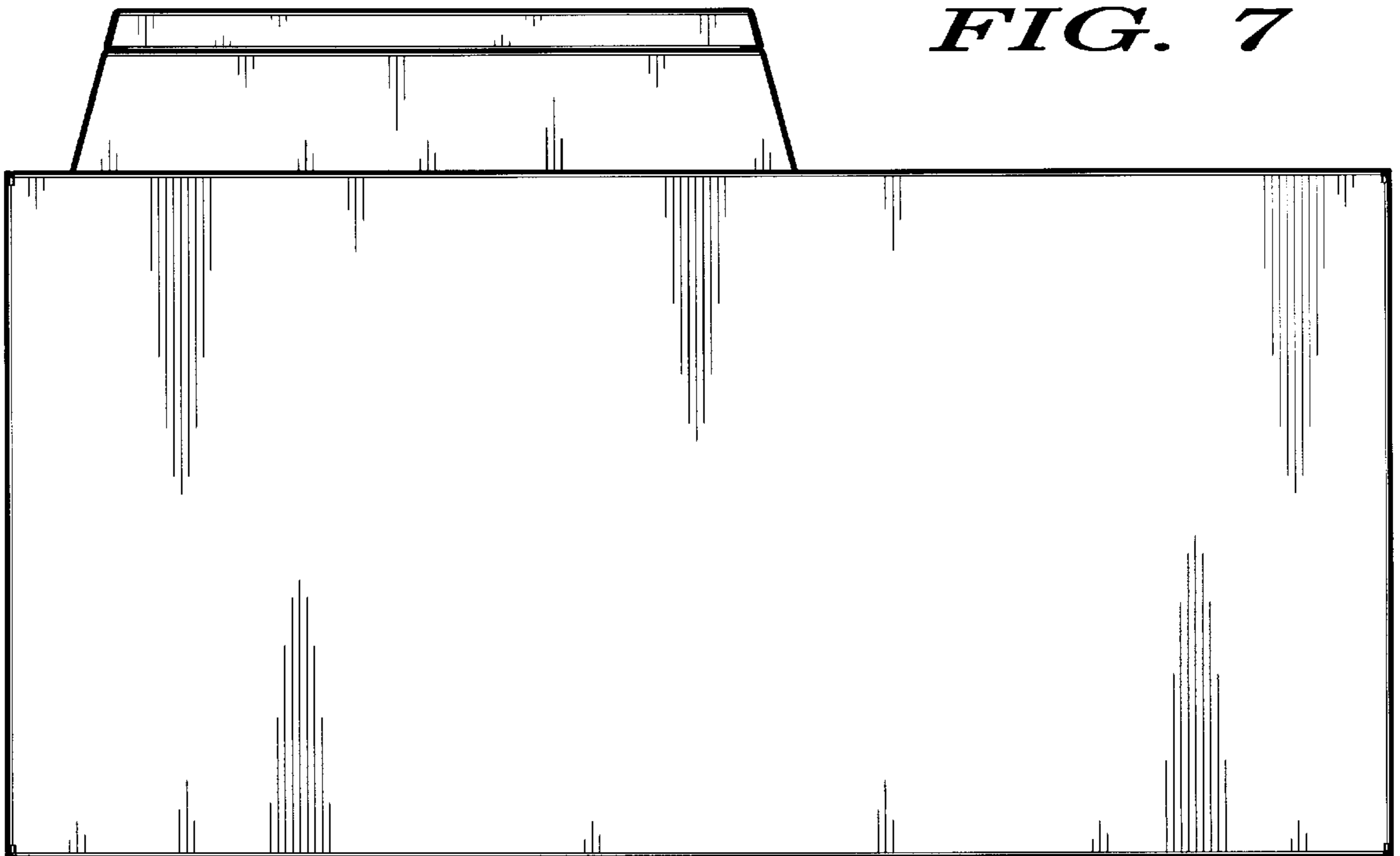
***FIG. 4***



*FIG. 5*



*FIG. 6*



*FIG. 7*