



US00D431505S

United States Patent [19]

[11] Patent Number: Des. 431,505

Kitamura et al.

[45] Date of Patent: ** Oct. 3, 2000

[54] RADIATOR GRILL OF A MOTOR VEHICLE

[57] CLAIM

[75] Inventors: Eiji Kitamura, Hiroshima; Tsuyoshi Toyoda; Yutaka Shimazu, both of Aki-gun; Satoru Akana, Hiroshima, all of Japan

The ornamental design for a radiator grill of a motor vehicle, as shown and described.

[73] Assignee: Mazda Motor Corporation, Hiroshima-Ken, Japan

DESCRIPTION

[**] Term: 14 Years

FIG. 1 is a perspective view of a radiator grill of a motor vehicle showing a first embodiment of our new design; FIG. 2 is a front view thereof; FIG. 3 is a rear view of thereof; FIG. 4 is a top view thereof; FIG. 5 is a bottom view thereof; FIG. 6 is a left side view thereof; FIG. 7 is a right side view thereof; FIG. 8 is an enlarged sectional view taken along the line 8—8 in FIG. 2; FIG. 9 is an enlarged sectional end view taken along the line 9—9 in FIG. 2; FIG. 10 is an enlarged sectional end view taken along the line 10—10 in FIG. 2; FIG. 11 is a perspective view of a radiator grill of a motor vehicle showing a second embodiment of our new design; FIG. 12 is a front view of FIG. 12; FIG. 13 is a rear view of FIG. 12; FIG. 14 is a top view of FIG. 12; FIG. 15 is a bottom view of FIG. 12; FIG. 16 is a left side view of FIG. 12; FIG. 17 is a right side view of FIG. 12; FIG. 18 is an enlarged sectional view taken along the line 18—18 in FIG. 12; FIG. 19 is an enlarged sectional end view taken along the line 19—19 in FIG. 12; and, FIG. 20 is an enlarged sectional end view taken along the line 20—20 in FIG. 12. The portion of the radiator grill shown in broken lines is for illustrative purpose only and forms no part of the claimed design.

[21] Appl. No.: 29/097,179

[22] Filed: Nov. 30, 1998

[51] LOC (7) Cl. 12-16

[52] U.S. Cl. D12/163

[58] Field of Search D12/163, 169, D12/90-92; 180/68.6, 69.21, 68.1; 293/115, 102

[56] References Cited

U.S. PATENT DOCUMENTS

D. 307,124	4/1990	Hayashi et al.	D12/163
D. 312,606	12/1990	Guelfi et al.	D12/163
D. 361,968	9/1995	Oyama	D12/163
D. 366,859	2/1996	Davis, Jr.	D12/163
D. 400,836	11/1998	Reynard et al.	D12/163
D. 403,285	12/1998	Abalos et al.	D12/163
D. 404,697	1/1999	Siltavuori	D12/163
D. 411,493	1/1999	Davis, Jr.	D12/163

FOREIGN PATENT DOCUMENTS

895621	1/1994	Japan .
896204	1/1994	Japan .
896282	1/1994	Japan .

Primary Examiner—Melody N. Brown
Attorney, Agent, or Firm—Sidley & Austin; Hugh A. Abrams

1 Claim, 12 Drawing Sheets

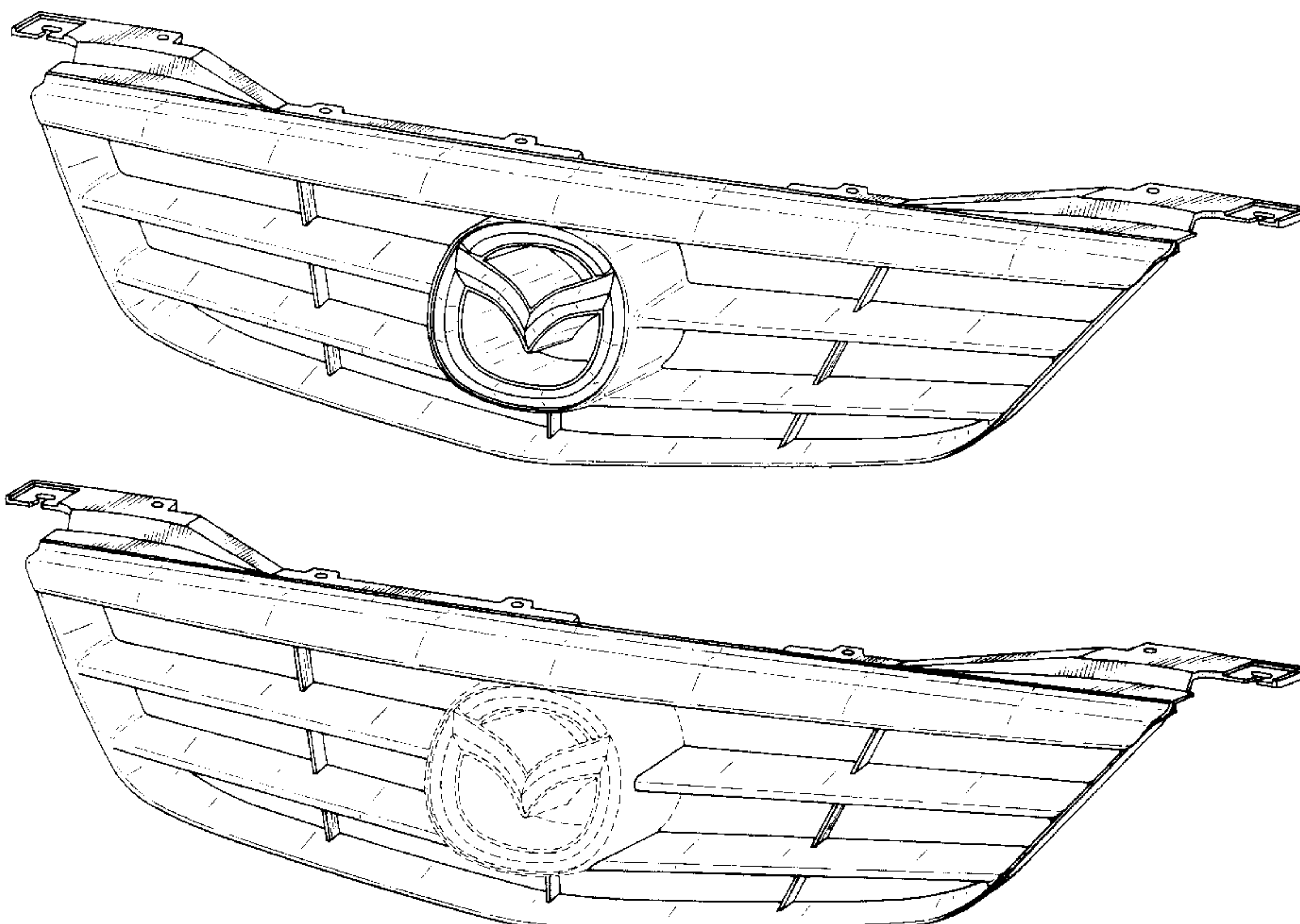

FIG. 1

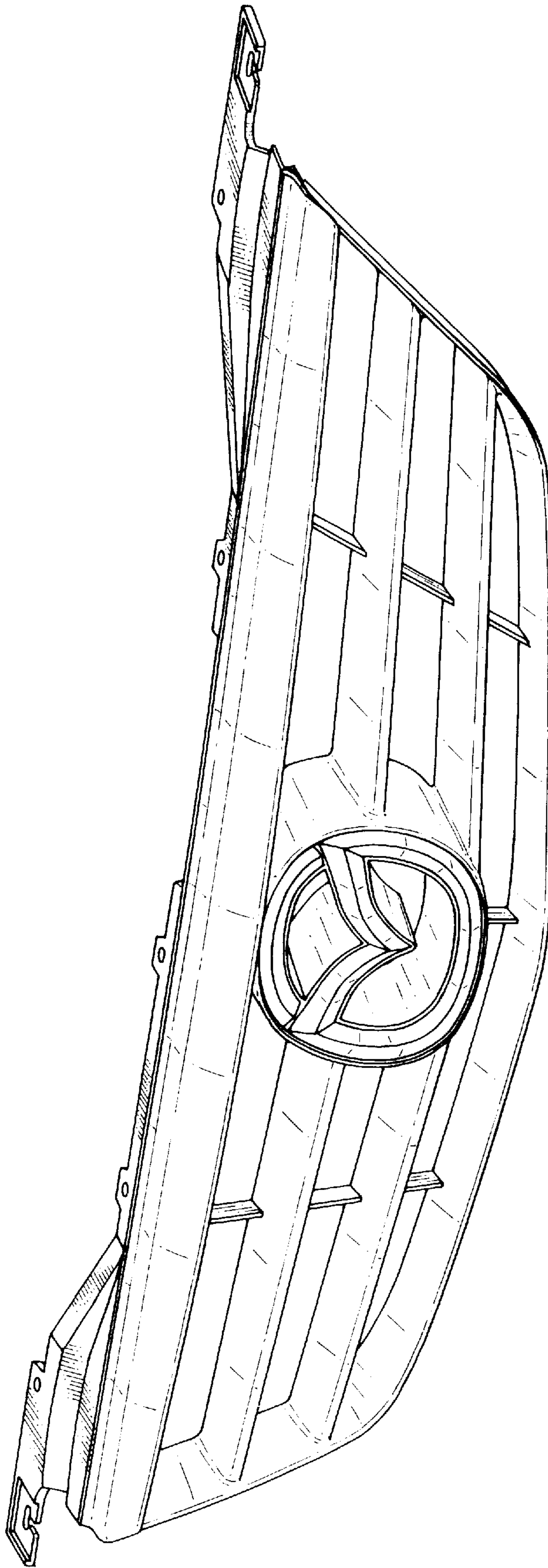

FIG. 2

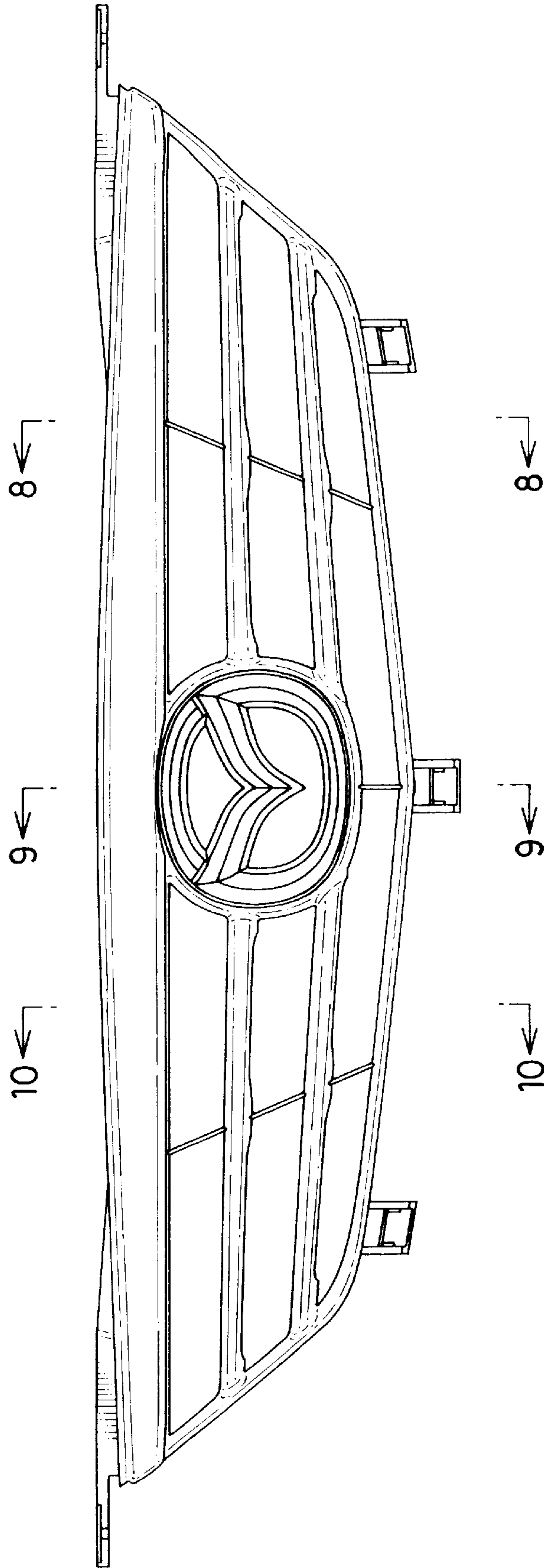

FIG. 3

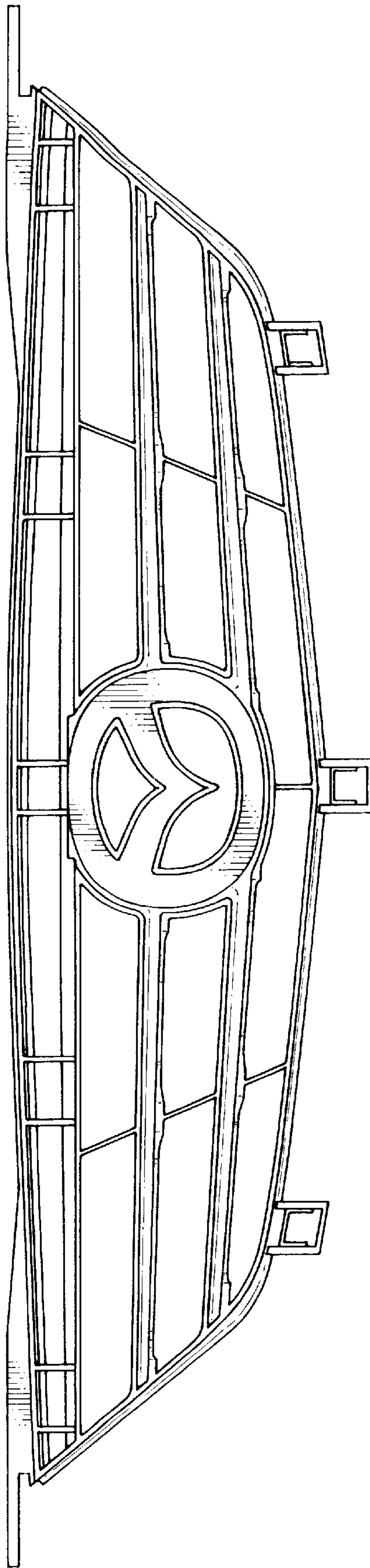

FIG. 4

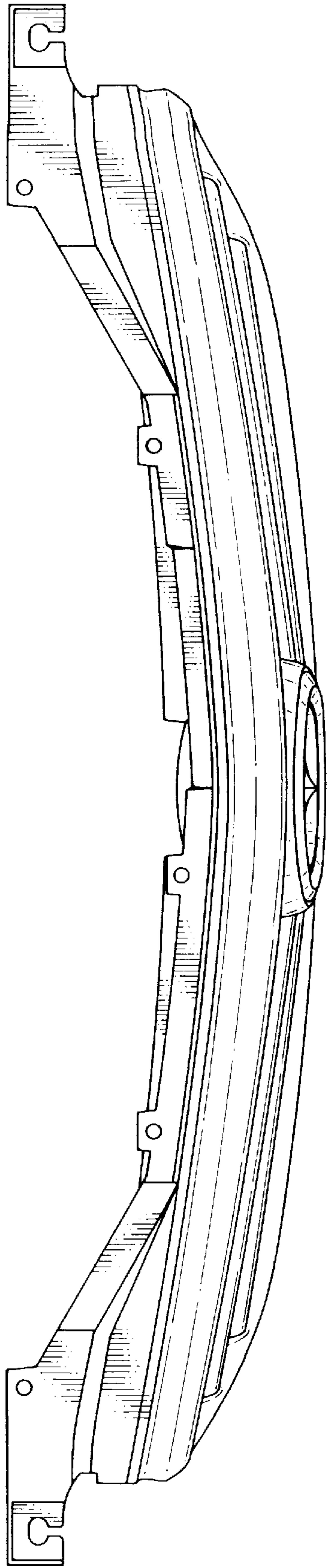

FIG. 5

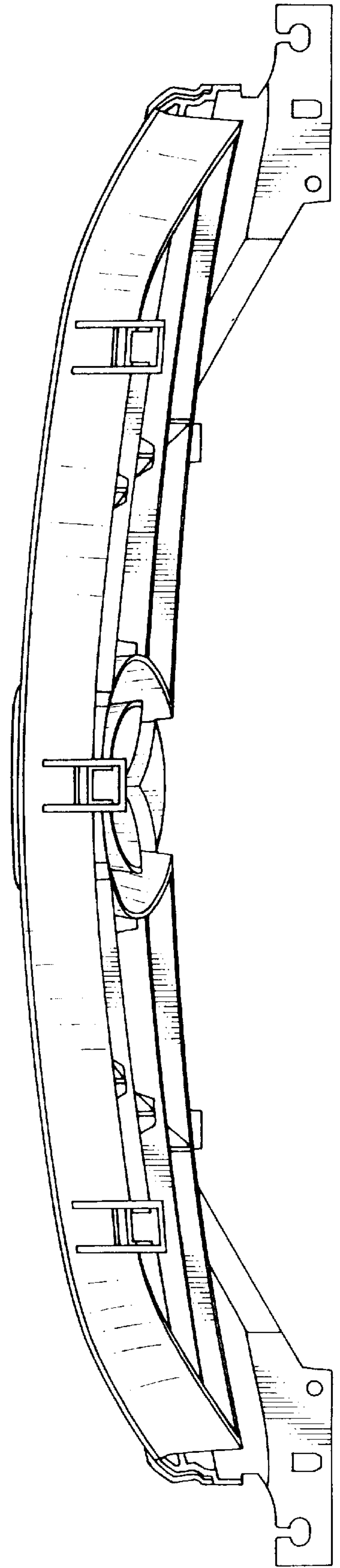

FIG. 7

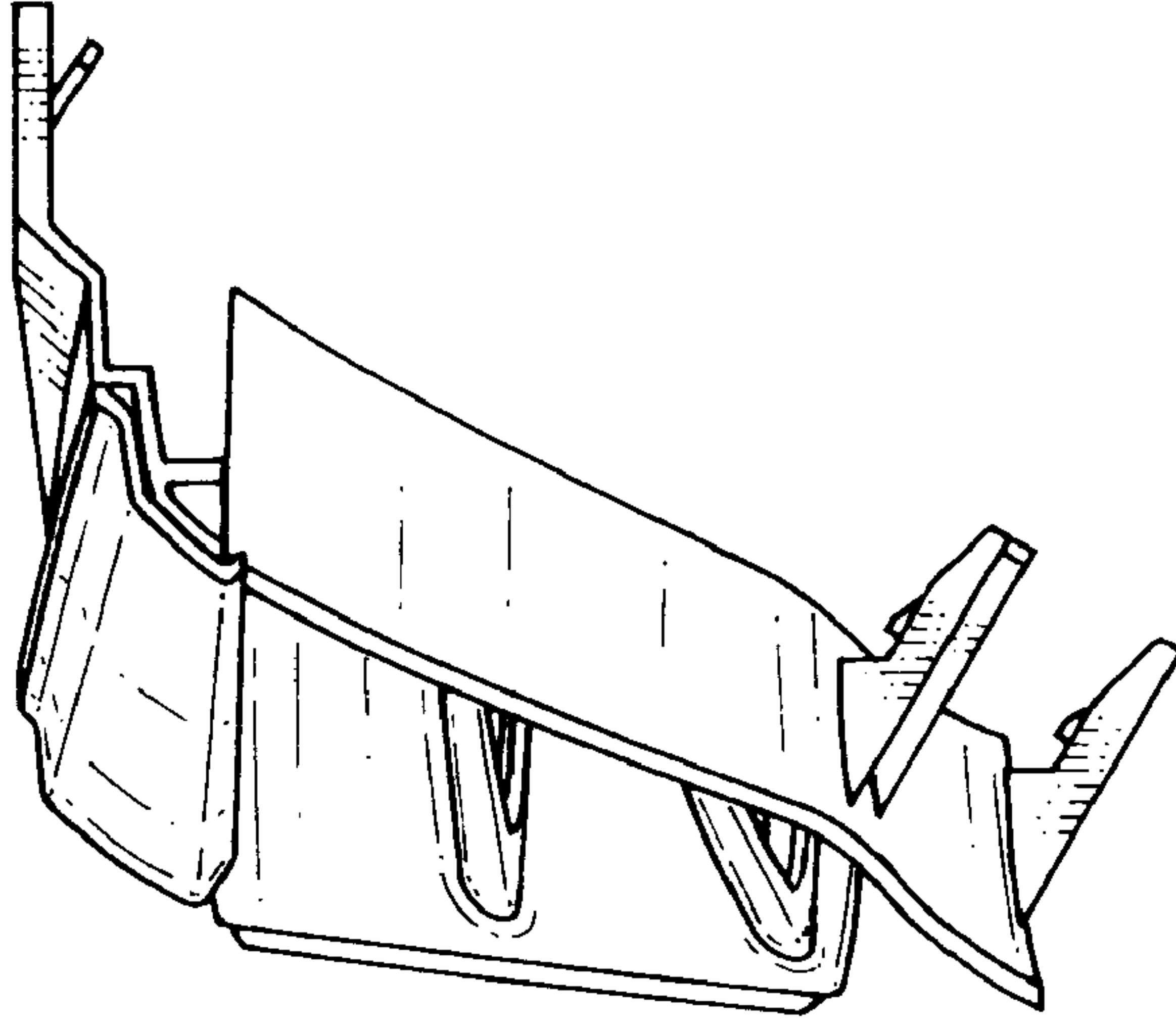

FIG. 6

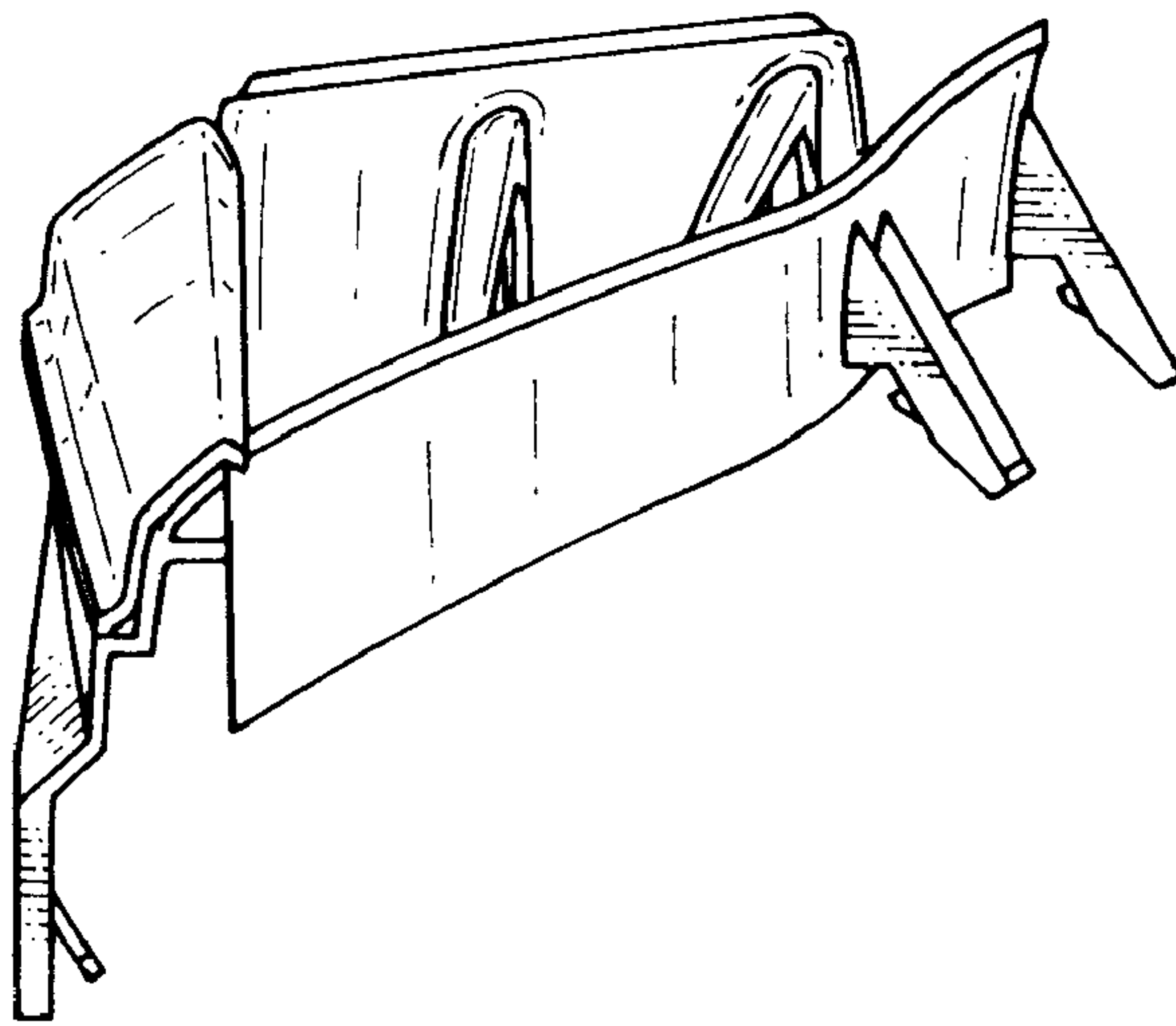

FIG. 8

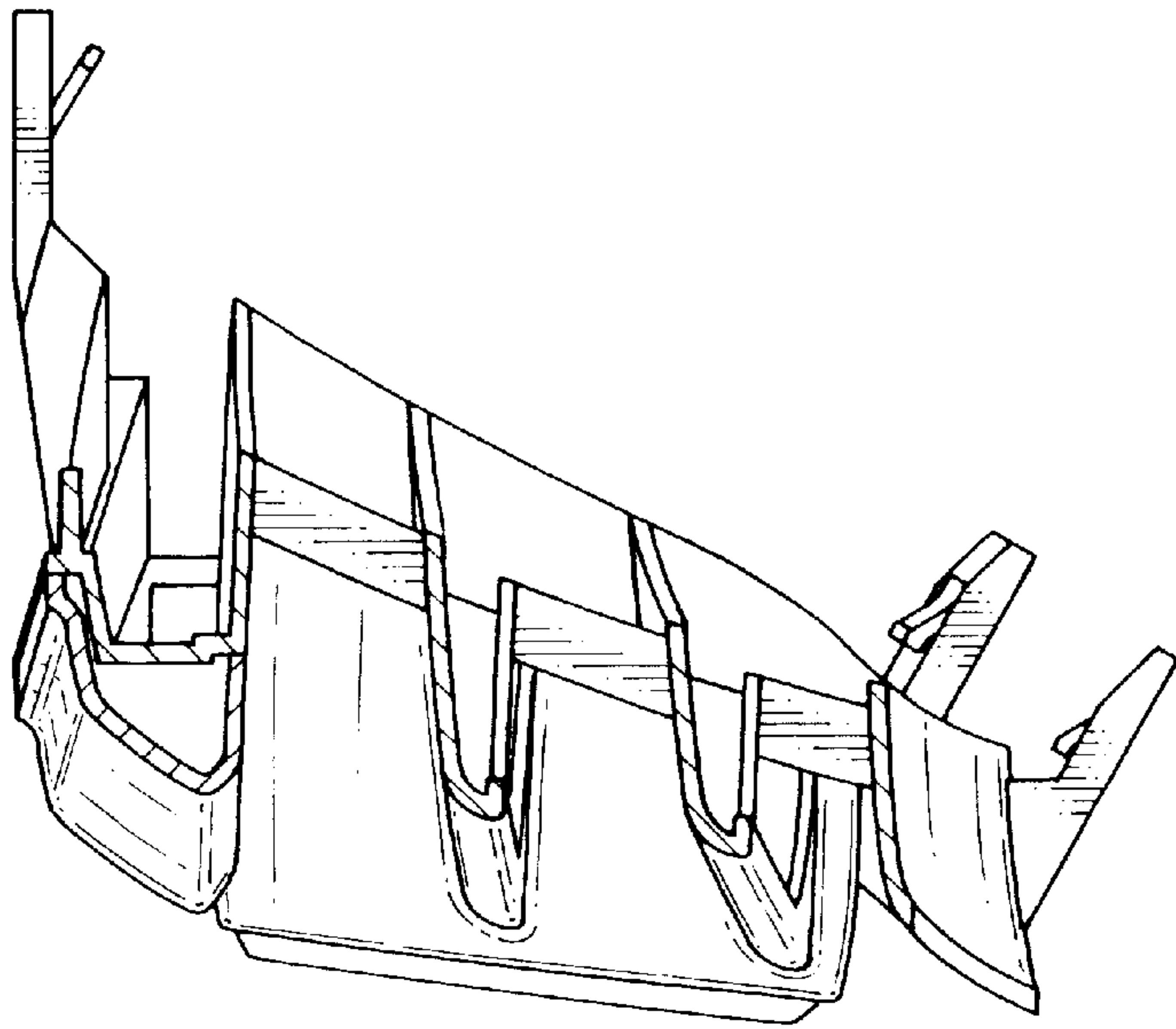

FIG. 9

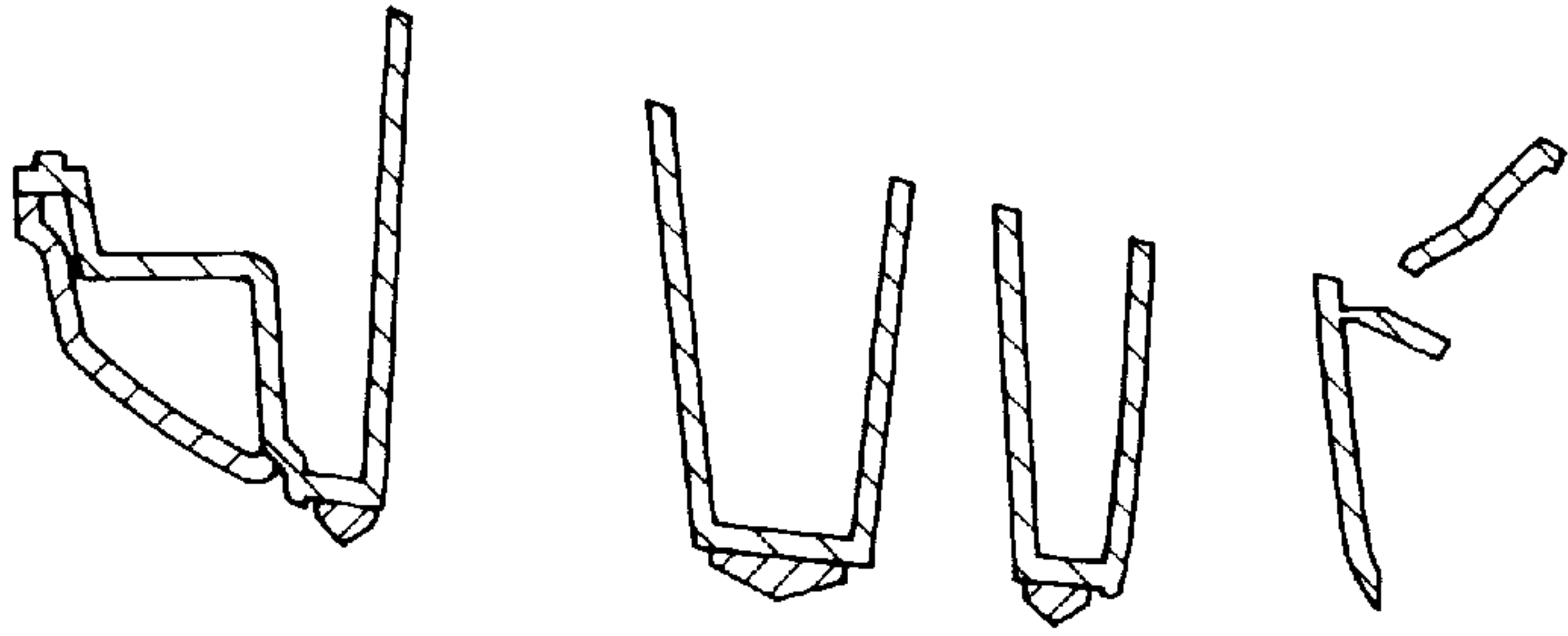

FIG. 10

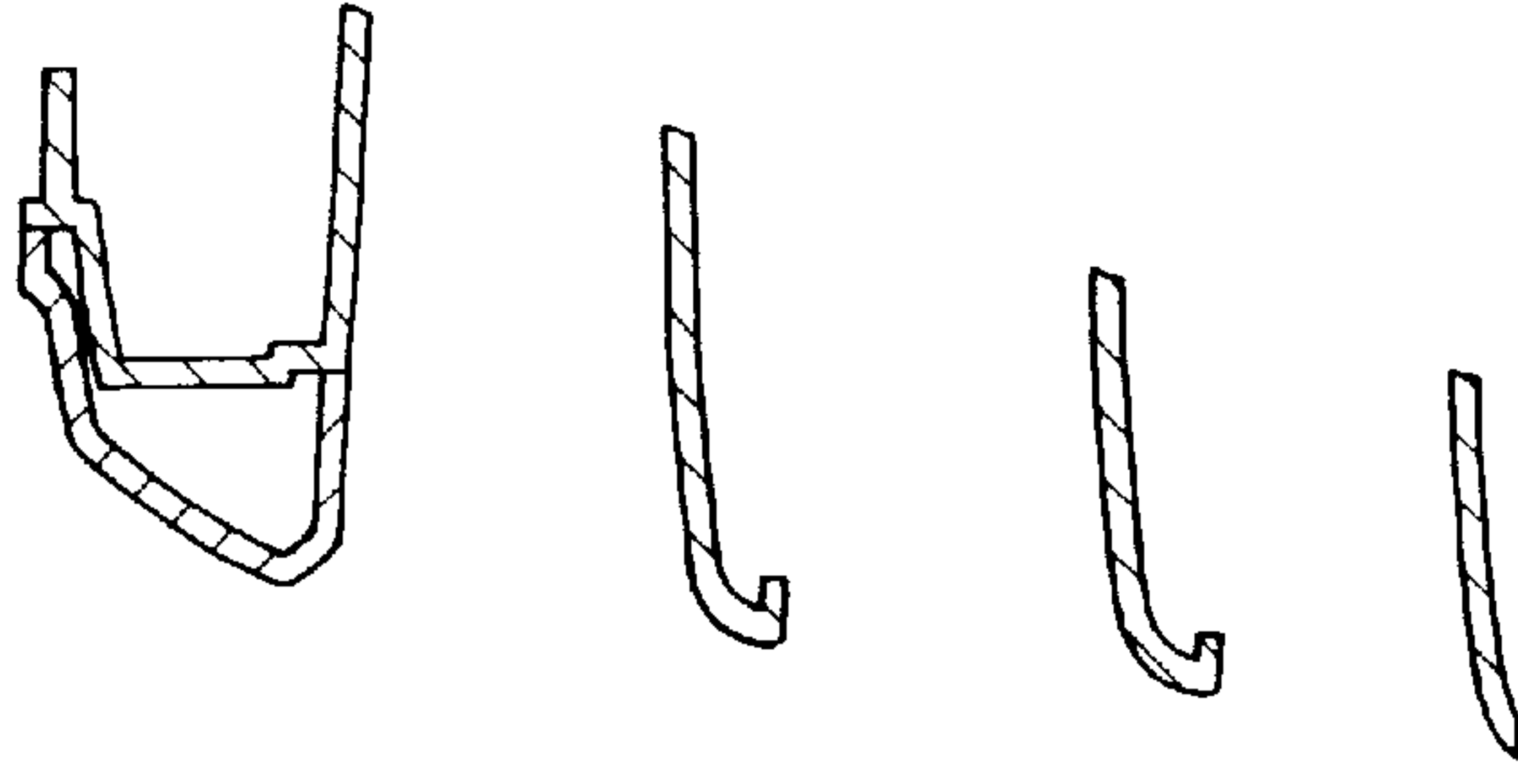

FIG. 11

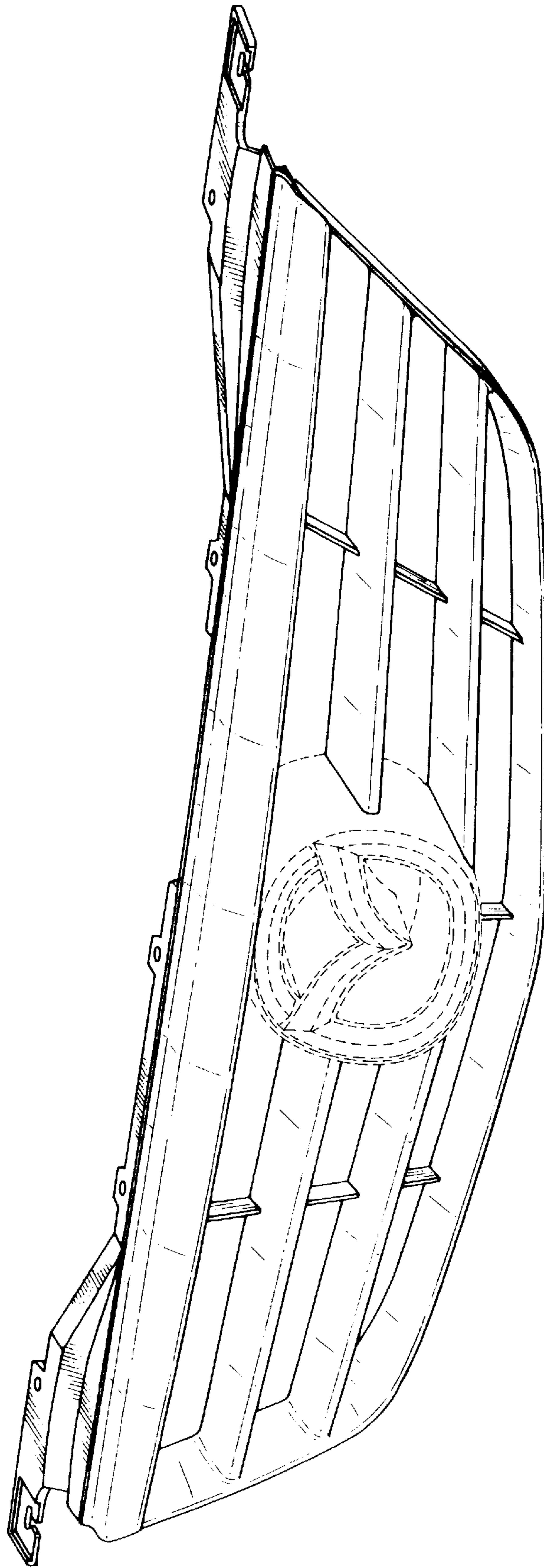

FIG. 12

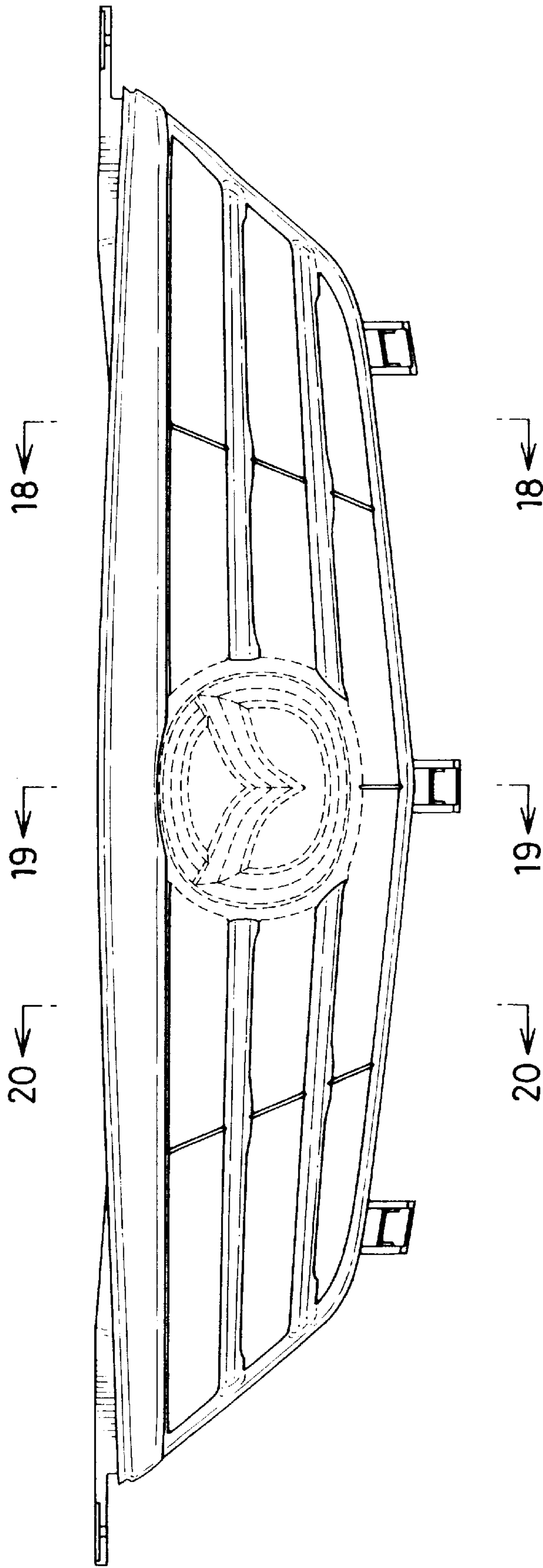

FIG. 13

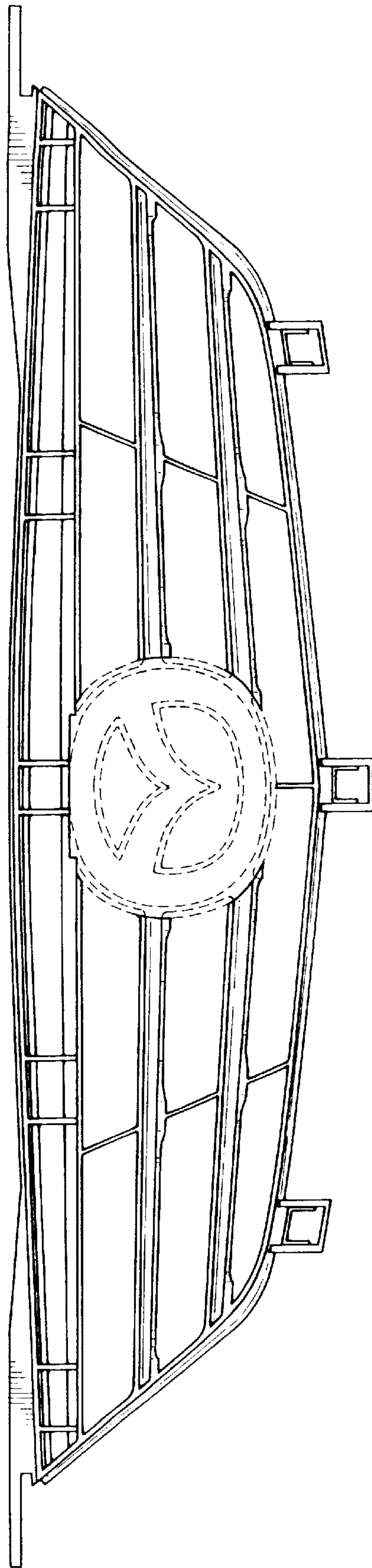

FIG. 14

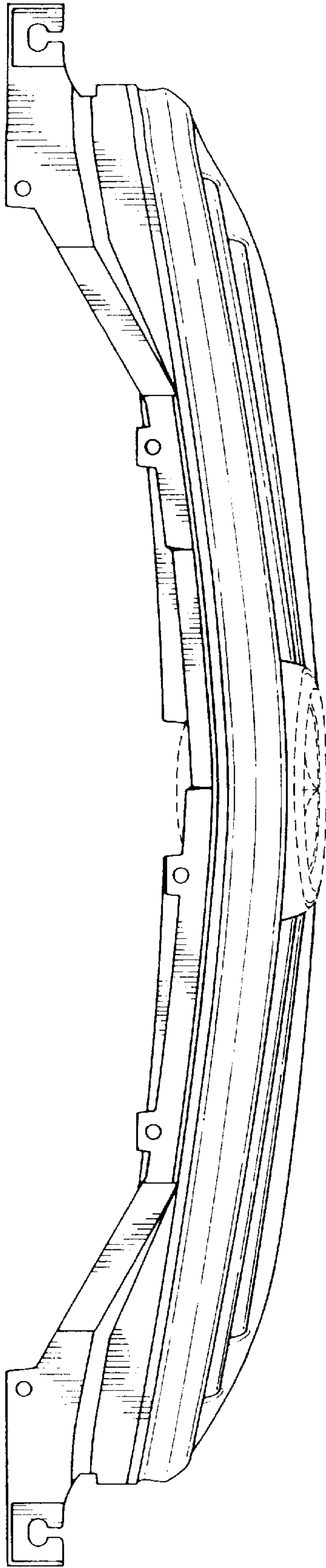

FIG. 15

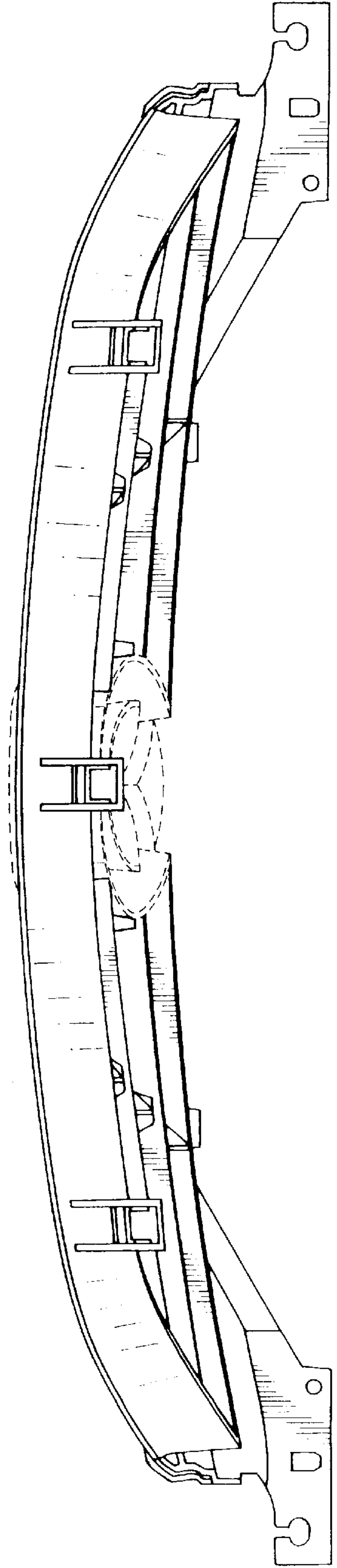

FIG. 17

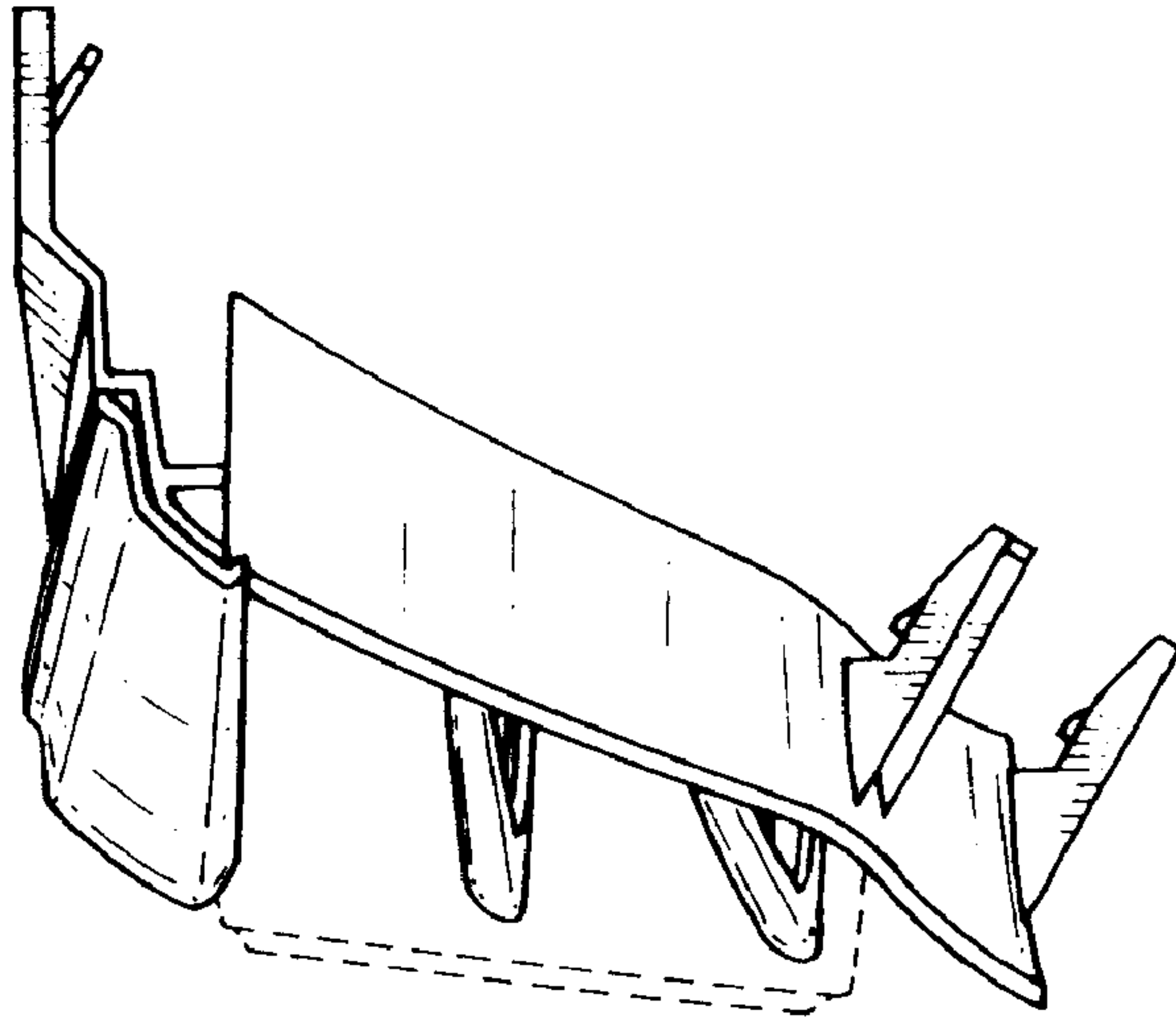

FIG. 16

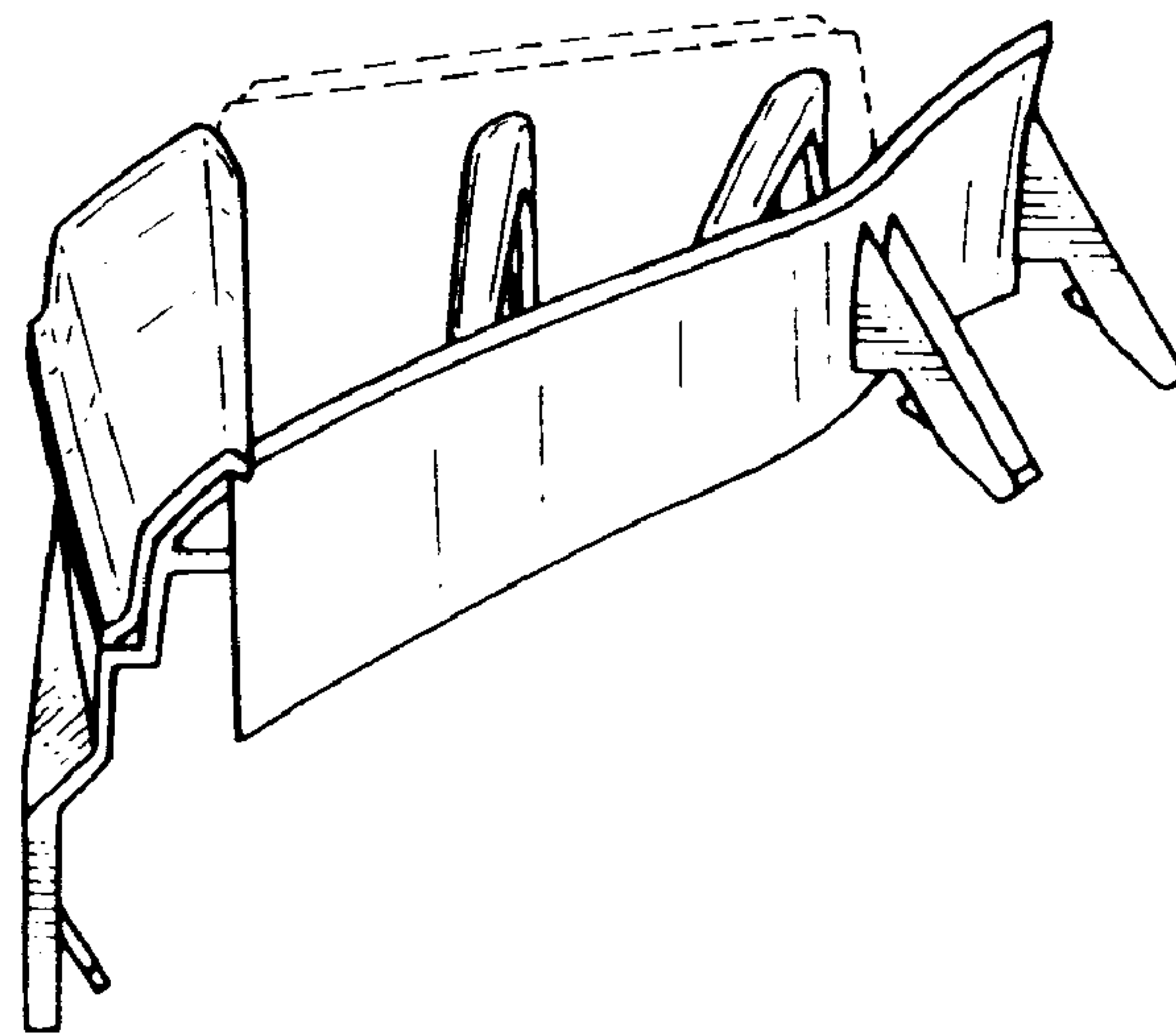

FIG. 18

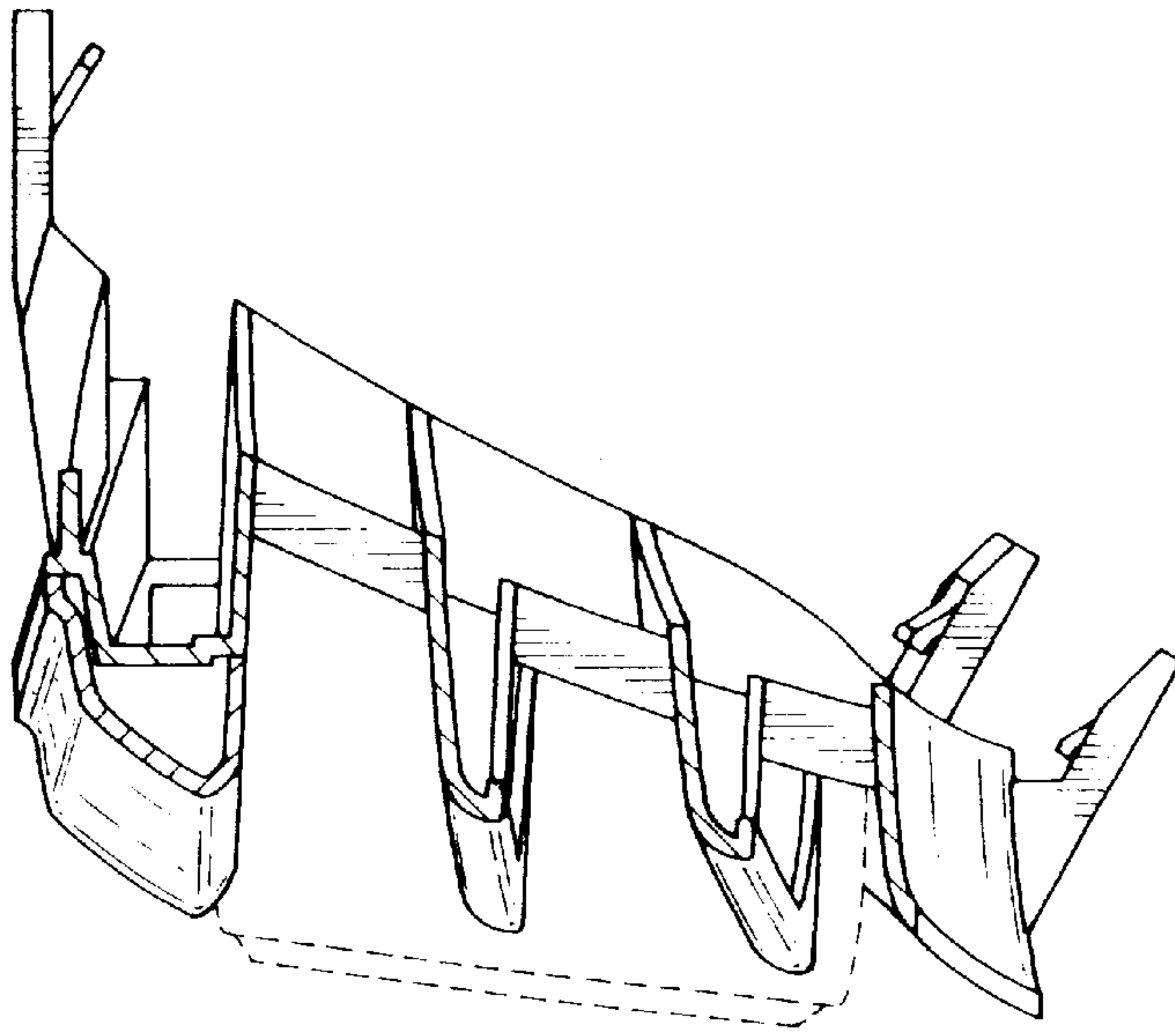

FIG. 19

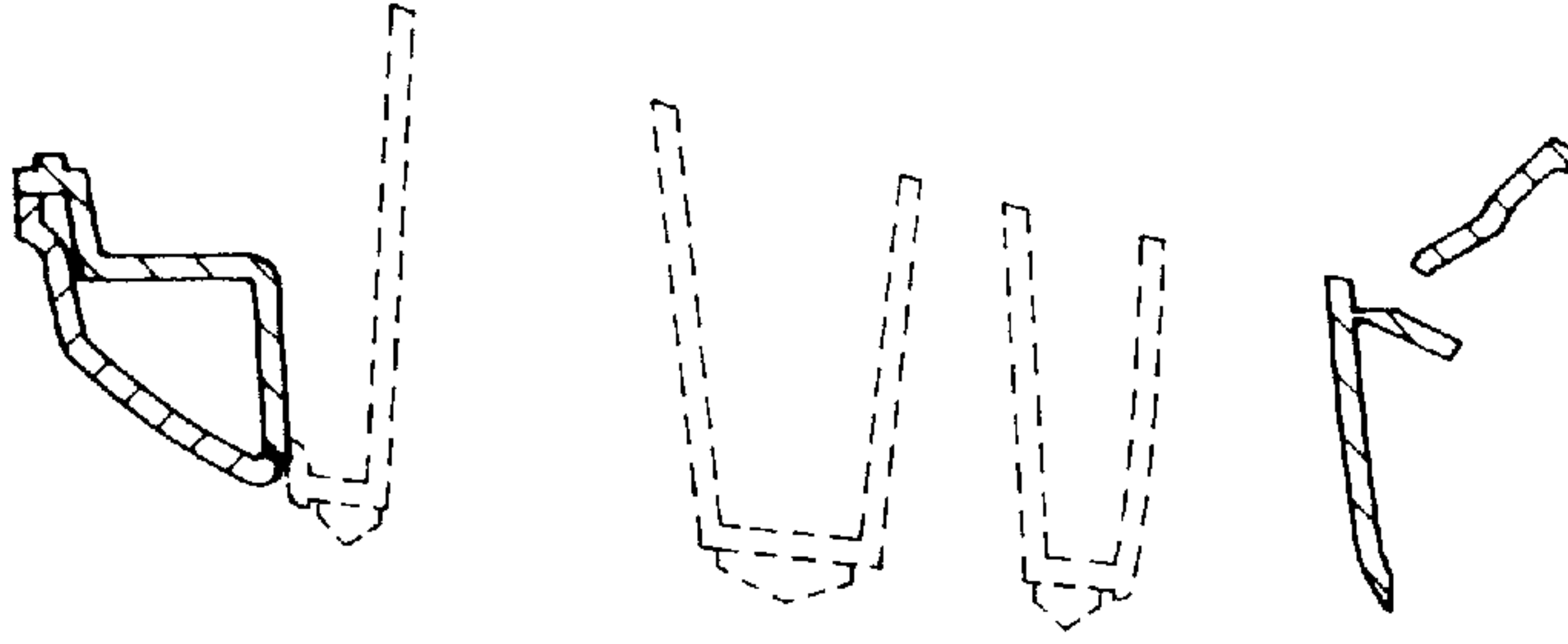

FIG. 20

