



US00D431450S

# United States Patent [19]

Maharg et al.

[11] Patent Number: Des. 431,450

[45] Date of Patent: \*\* Oct. 3, 2000

[54] MOUNTING BRACKET

[75] Inventors: James C. Maharg, Ridgefield, Conn.; Zenda Snyder, New York City, N.Y.

[73] Assignee: Look, Inc., New York, N.Y.

[\*\*] Term: 14 Years

[21] Appl. No.: 29/098,722

[22] Filed: Jan. 5, 1999

### Related U.S. Application Data

[63] Continuation of application No. 09/138,709, Aug. 24, 1998, Pat. No. 6,027,089.

[51] LOC (7) Cl. .... 08-05

[52] U.S. Cl. .... D8/363

[58] Field of Search ..... D8/354, 380, 363; 248/220.21, 222.12, 222.52, 300, 224.51, 205.1; 403/103

### [56] References Cited

#### U.S. PATENT DOCUMENTS

5,507,545 4/1996 Krysiak ..... 248/222.12 X  
5,667,188 9/1997 Bettinsoli ..... 248/558

Primary Examiner—Holly Baynham  
Attorney, Agent, or Firm—Levisohn, Lerner, Berger & Langsam

### [57] CLAIM

The ornamental design for a mounting bracket, as shown and described.

### DESCRIPTION

FIG. 1 is a front perspective view of the preferred embodiment of the mounting bracket of this invention.

FIG. 2 is a top plan view of the mounting bracket shown in FIG. 1.

FIG. 3 is a left plan view of the mounting bracket of the embodiment of the invention shown in FIG. 1.

FIG. 4 is a front plan view of the mounting bracket of the invention shown in FIG. 1.

FIG. 5 is a bottom plan view of the mounting bracket of the invention shown in FIG. 1.

FIG. 6 is a rear plan view of the mounting bracket of the invention shown in FIG. 1.

FIG. 7 is a rear perspective view of the mounting bracket of the invention shown in FIG. 1.

FIG. 8 is a right plan view of the mounting bracket of the invention shown in FIG. 1.

FIG. 9 is a front perspective view of the mounting bracket of the invention as shown in FIG. 1 in an alternate embodiment as adapted to support a shelf. The broken line showing of a shelf support is for illustrative purposes only and forms no part of the claimed design. The portion of the mounting bracket obscured by the broken line portion is identical to the corresponding structure in FIG. 1.

1 Claim, 4 Drawing Sheets

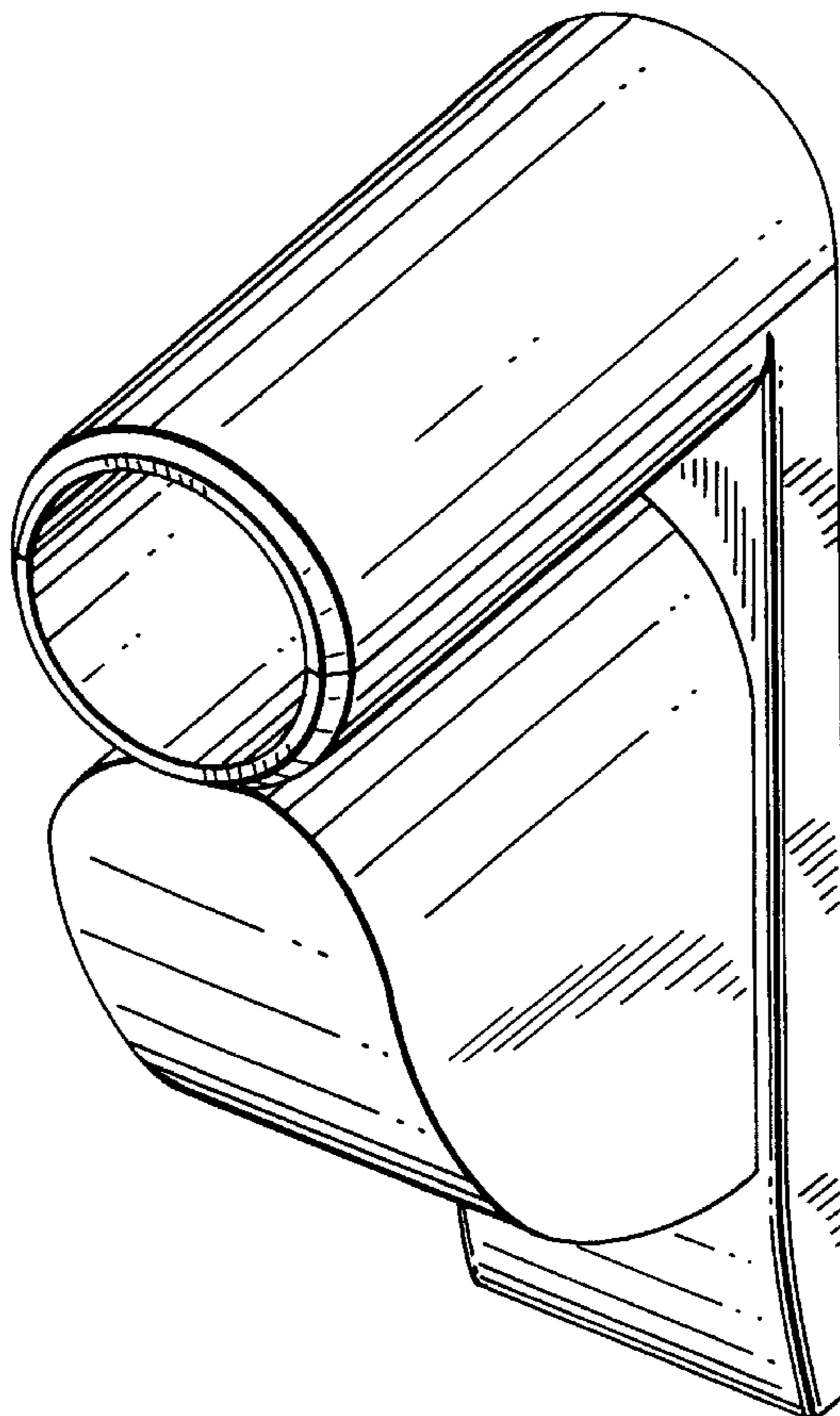

*FIG. 1*

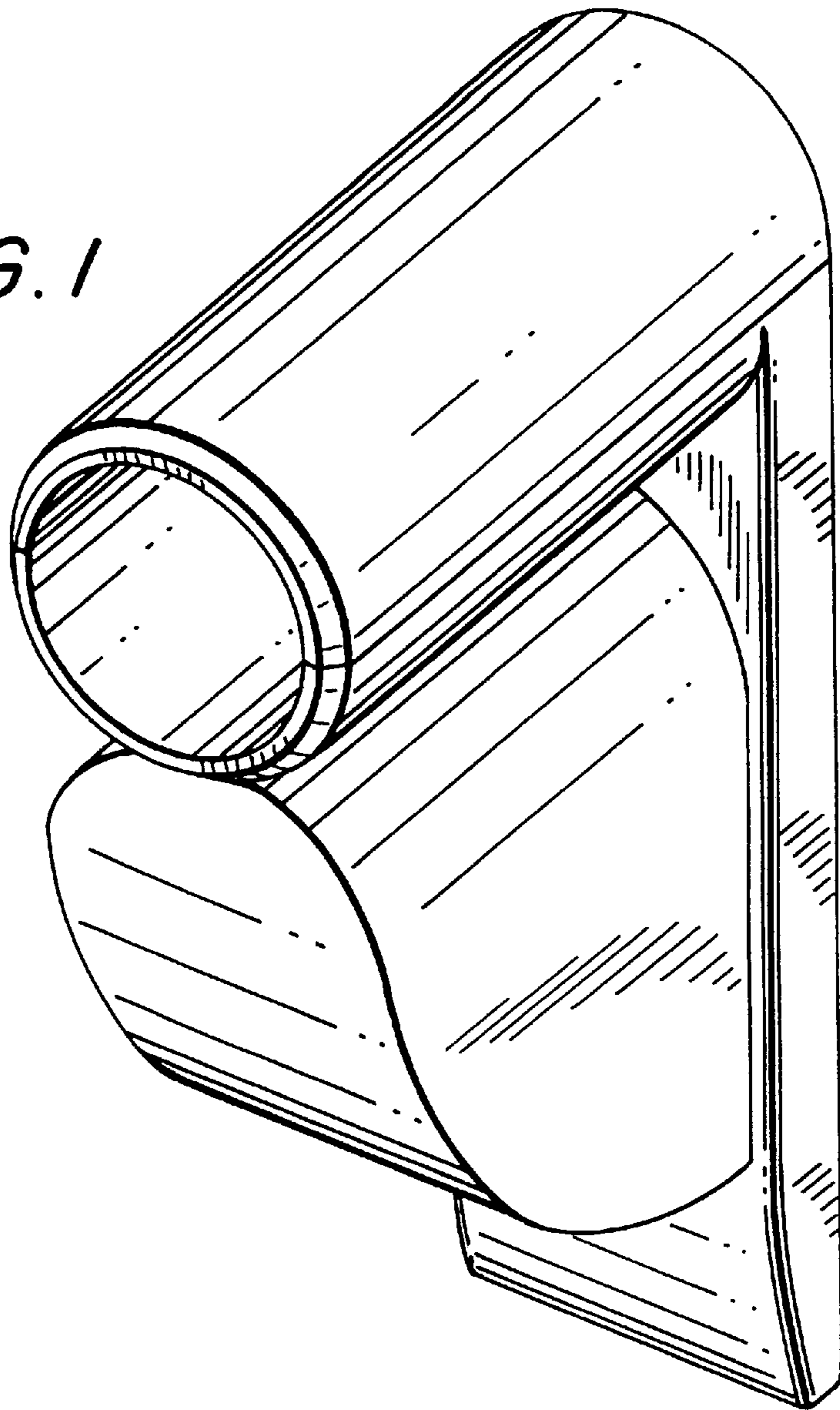

*FIG. 2*

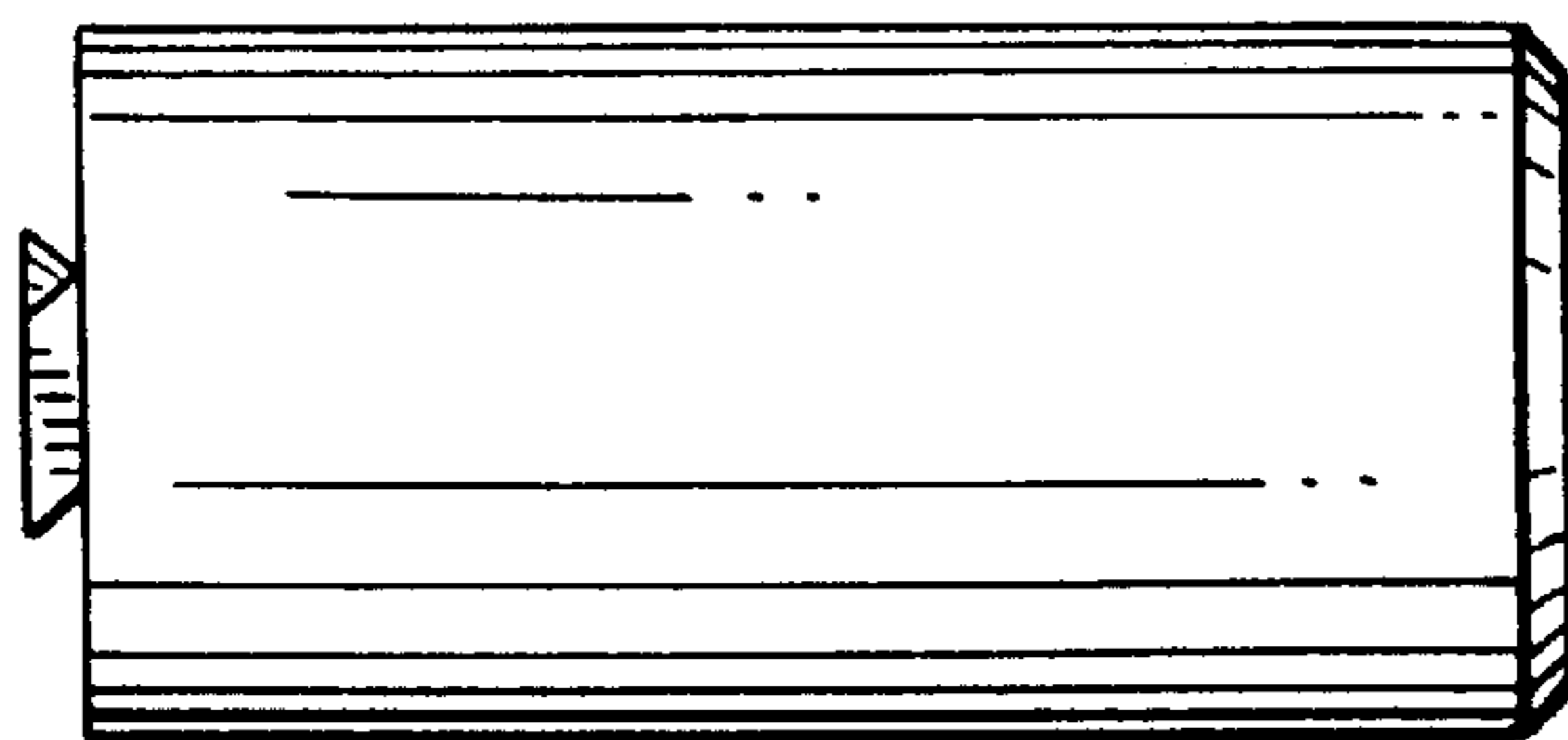

*FIG. 3*

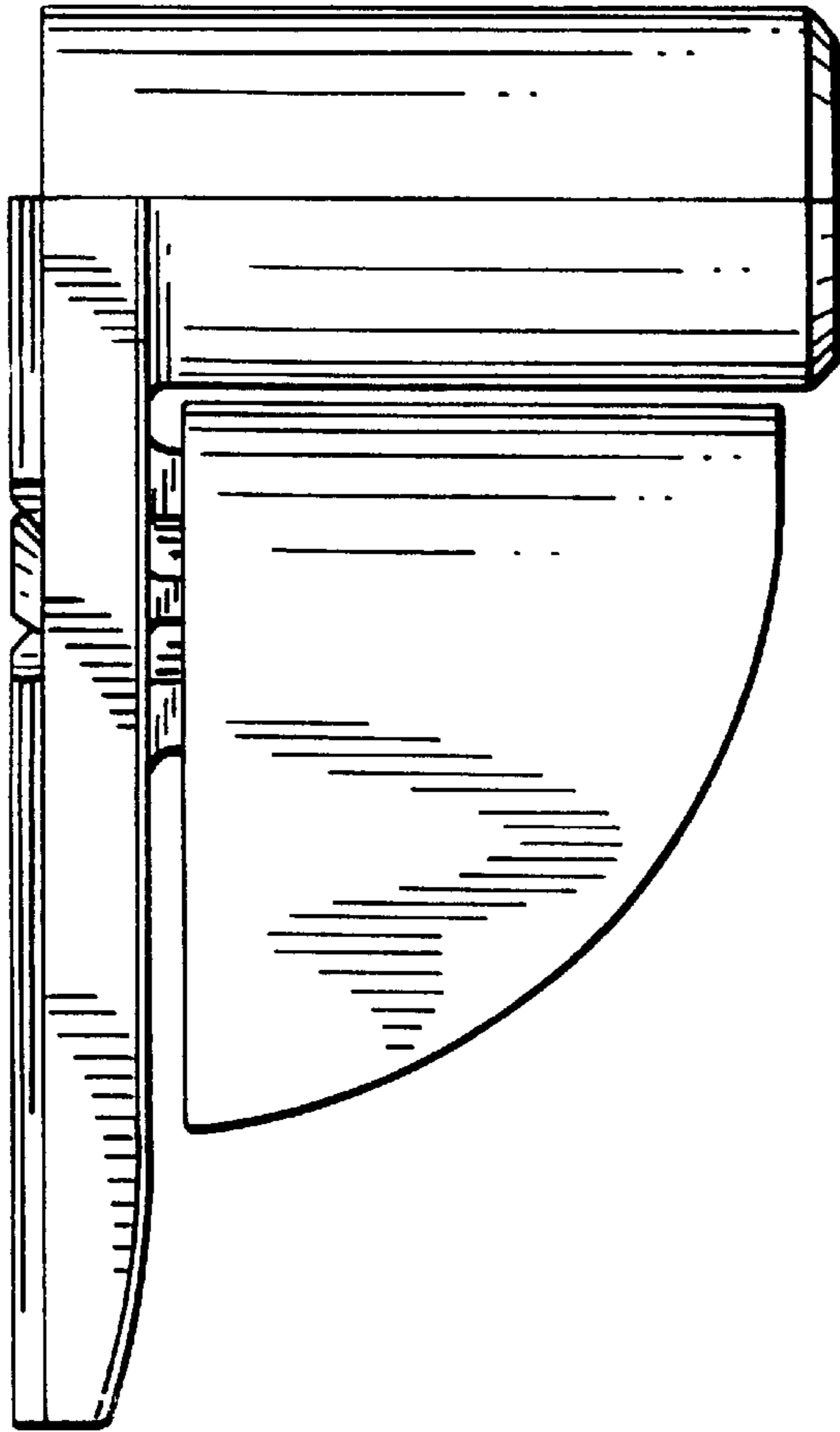

*FIG. 4*

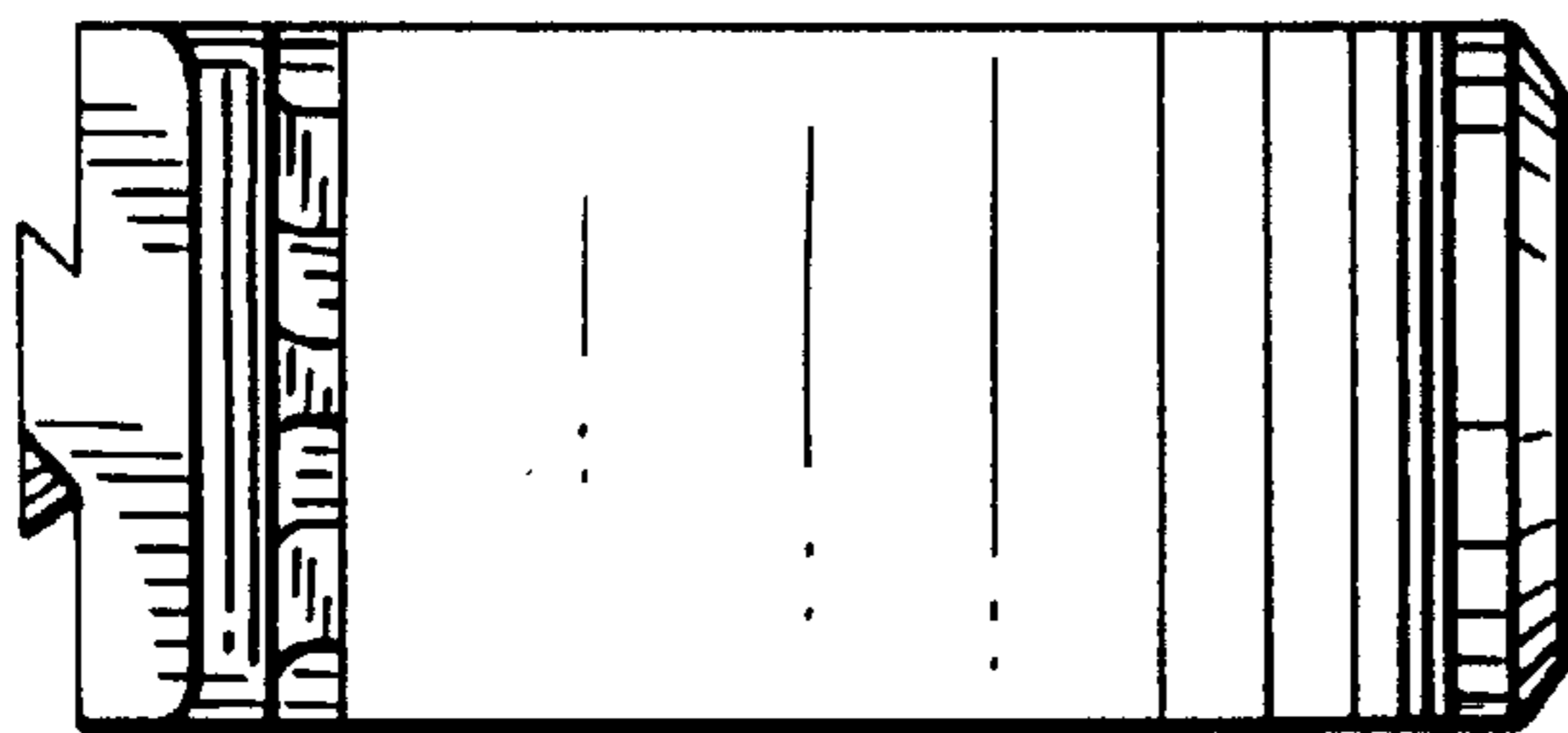
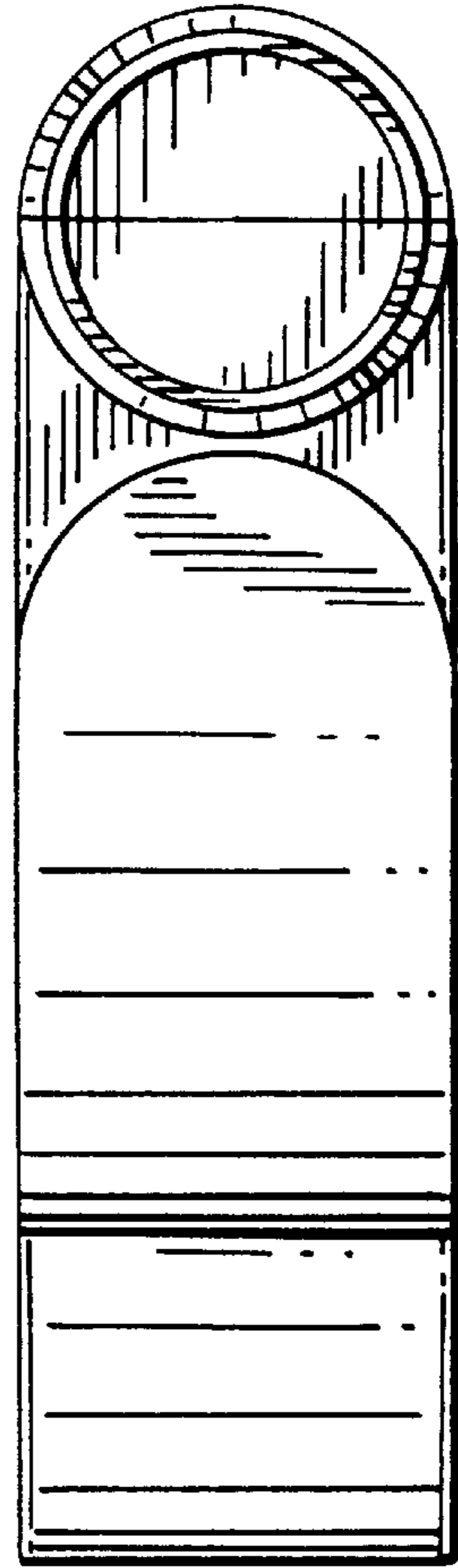

*FIG. 5*

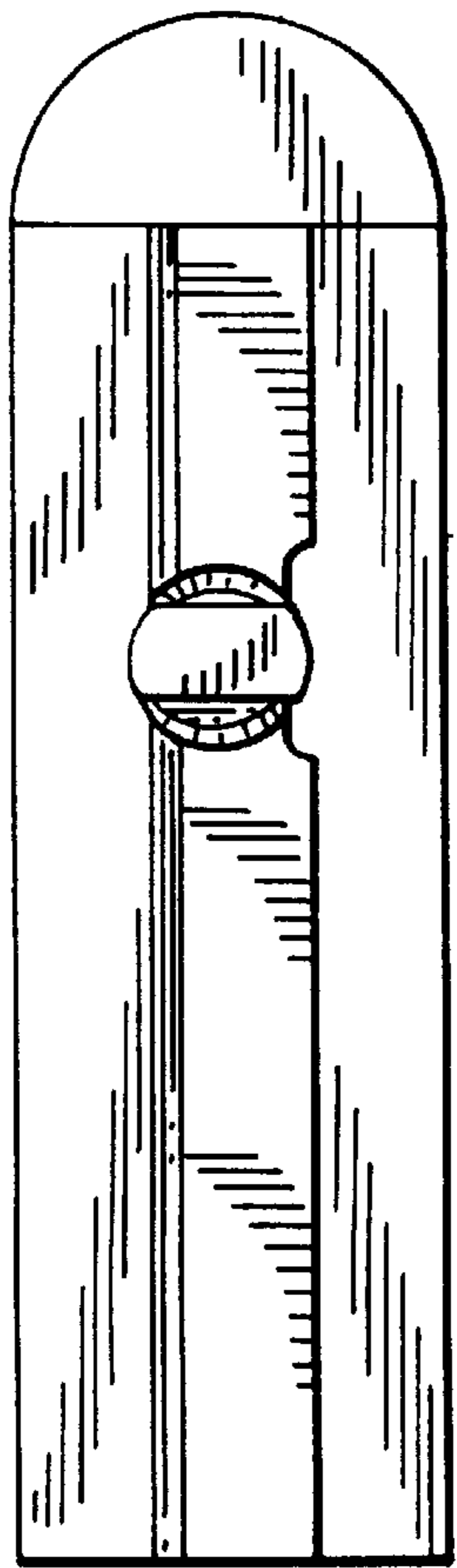

*FIG. 6*

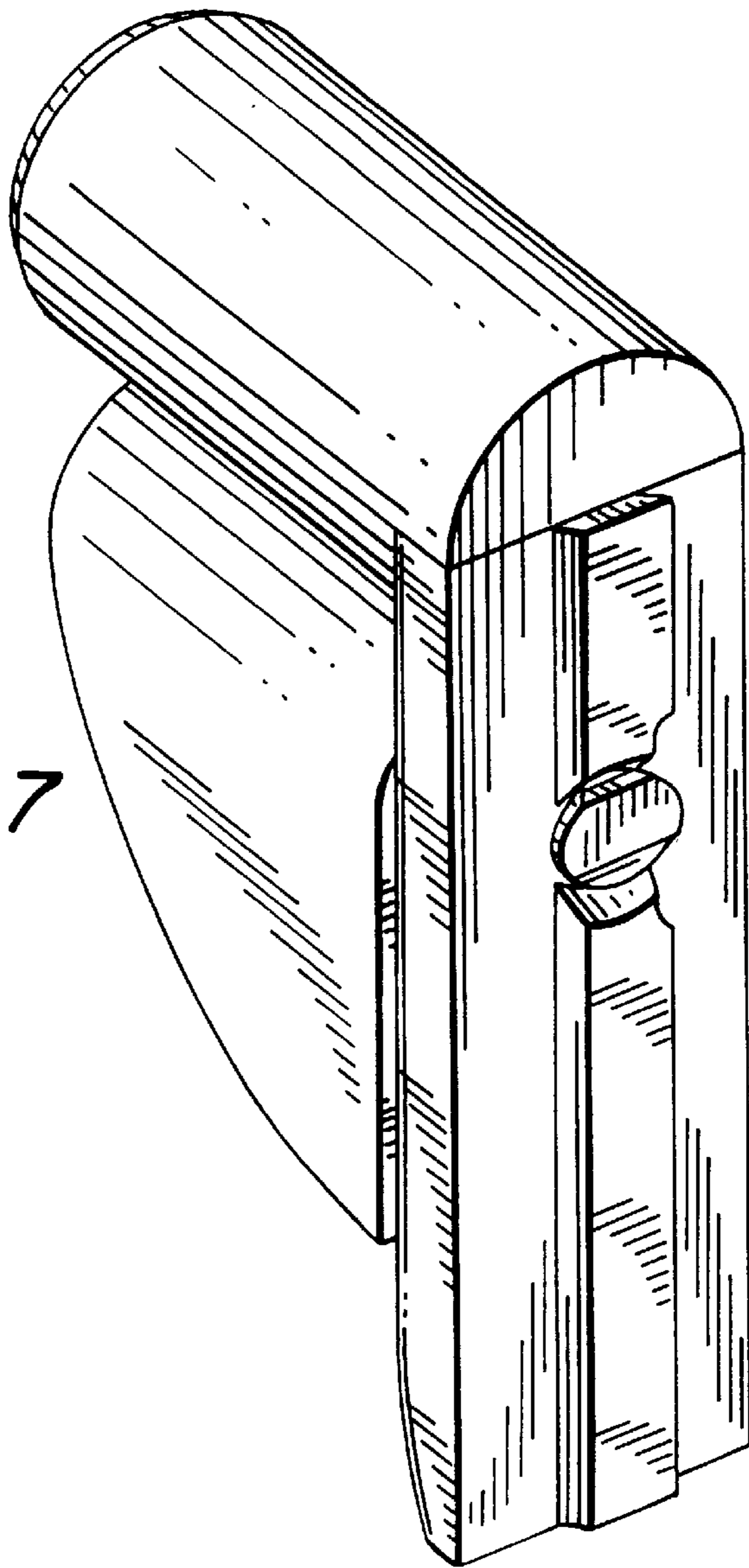

*FIG. 7*



*FIG. 8*

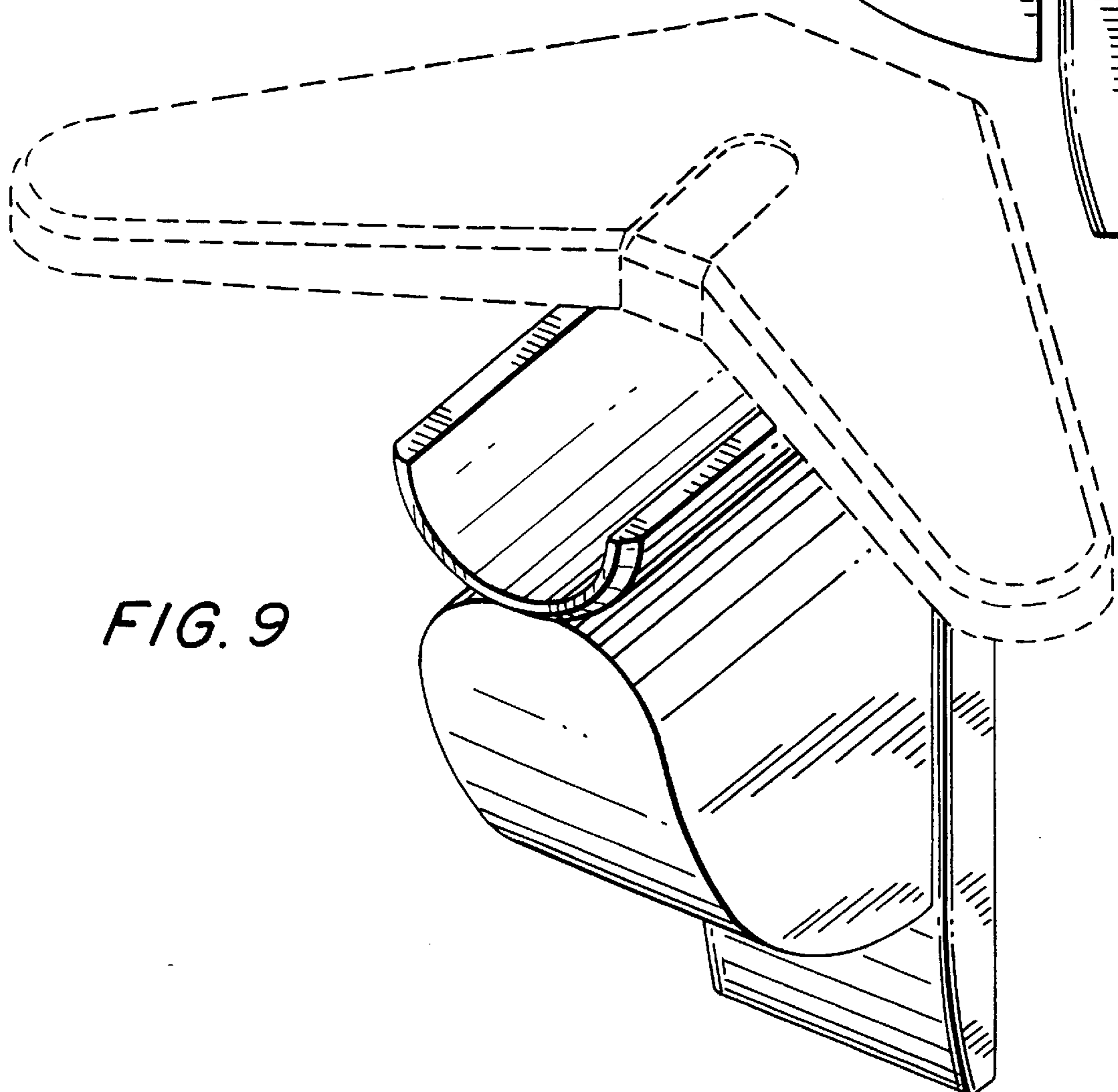
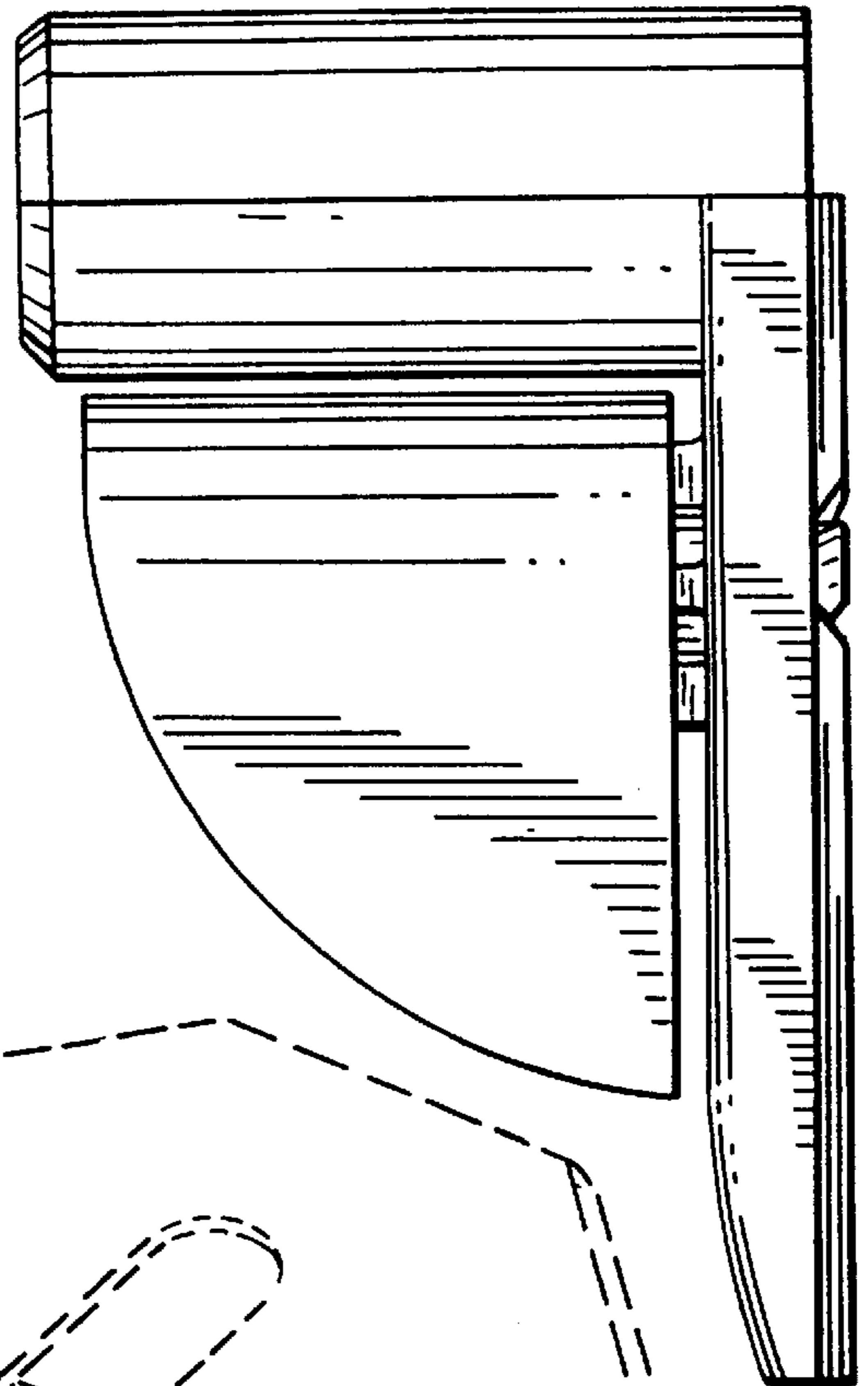

*FIG. 9*