



US00D431225S

United States Patent [19]

Perlman et al.

[11] Patent Number: **Des. 431,225**

[45] Date of Patent: **** Sep. 26, 2000**

[54] **PICK-UP TRUCK CAP**

[75] Inventors: **Daniel Perlman**, Auburn; **James DeTemple**, Shillington, both of Pa.

[73] Assignee: **Reading Body Works, Inc.**, Shillington, Pa.

[**] Term: **14 Years**

[21] Appl. No.: **29/117,115**

[22] Filed: **Jan. 17, 2000**

[51] **LOC (7) Cl.** **12-16**

[52] **U.S. Cl.** **D12/404**

[58] **Field of Search** D12/401, 403-405; 296/10, 99.1, 100, 105-108, 156, 164-165, 175

[56] **References Cited**

U.S. PATENT DOCUMENTS

D. 241,530	9/1976	Hayes	D12/404
D. 244,182	5/1977	Skidmore et al.	D12/404
D. 249,675	9/1978	Mashigan	D12/404
D. 271,757	12/1983	Miller	D12/404
D. 290,945	7/1987	Geisler	D12/404
D. 299,223	1/1989	Galvin	D12/404
D. 310,806	9/1990	Hertzberg et al.	D12/404
D. 324,015	2/1992	Quiniones	D12/404
D. 326,441	5/1992	Rogers	D12/404

D. 328,049	7/1992	Sturtevant	D12/404
D. 332,934	2/1993	Brown et al.	D12/404
D. 367,463	2/1996	Reiland	D12/404
D. 379,173	5/1997	Quiniones	D12/404
D. 388,049	12/1997	Reardon	D12/404
D. 407,062	3/1999	Patrovich	D12/404

Primary Examiner—Stacia Cadmus
Attorney, Agent, or Firm—Schnader, Harrison, Segal & Lewis, LLP

[57] **CLAIM**

The ornamental design for a pick-up truck cap, as shown and described.

DESCRIPTION

FIG. 1 is a rear perspective view of a pick-up truck cap, showing our new design;
 FIG. 2 is a reduced left side elevational view thereof;
 FIG. 3 is a reduced right side elevational view thereof;
 FIG. 4 is a reduced top plan view thereof;
 FIG. 5 is a reduced front view thereof as seen along lines 5-5 in FIG. 4; and,
 FIG. 6 is a reduced rear elevational view thereof.

The bottom plan view is not shown because it forms no part of the invention. The broken line showing of the pick-up truck, and various parts and features is for illustrative and contextual purposes only and forms no part of the claimed invention.

1 Claim, 5 Drawing Sheets

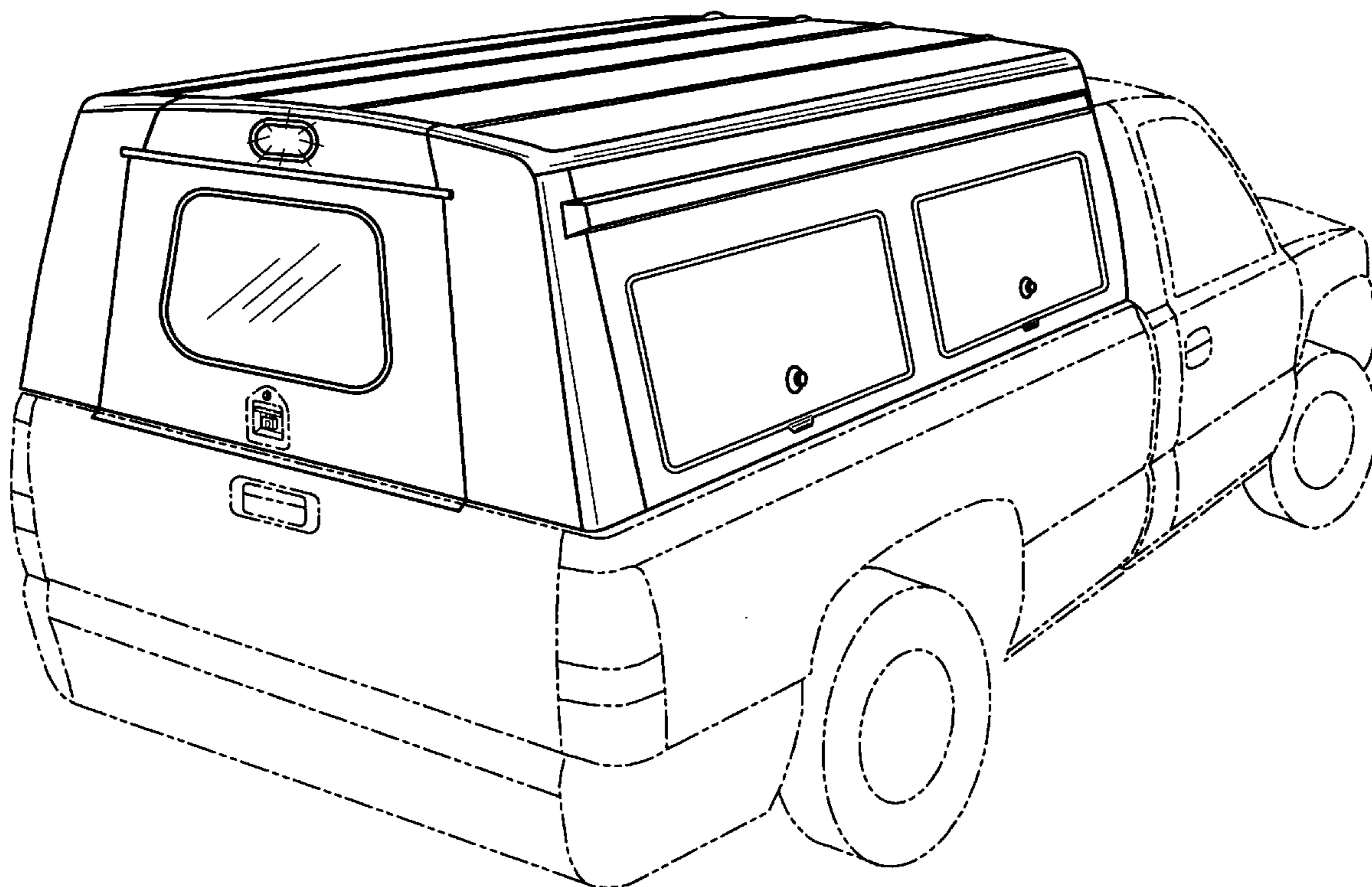

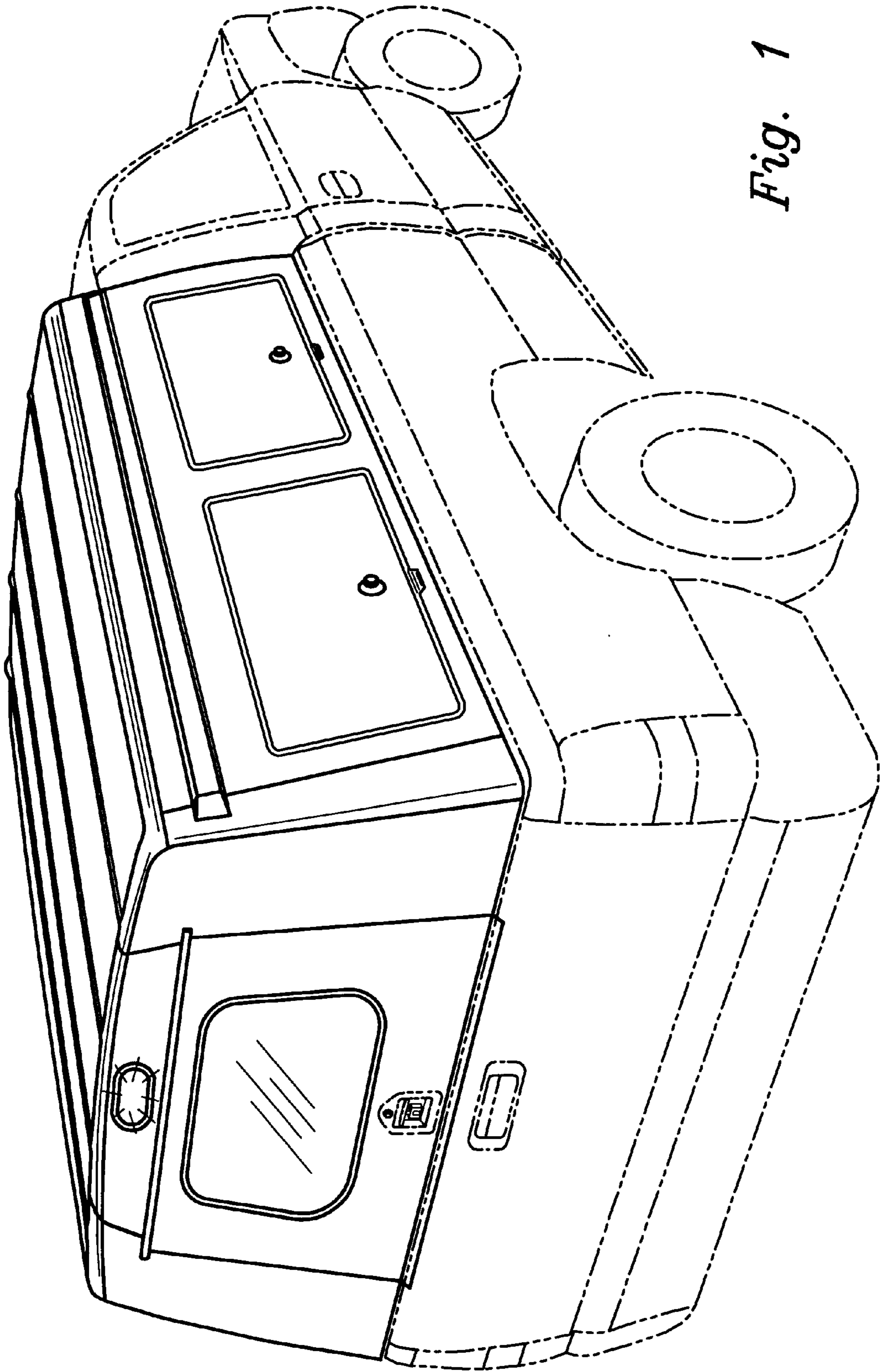

Fig. 1

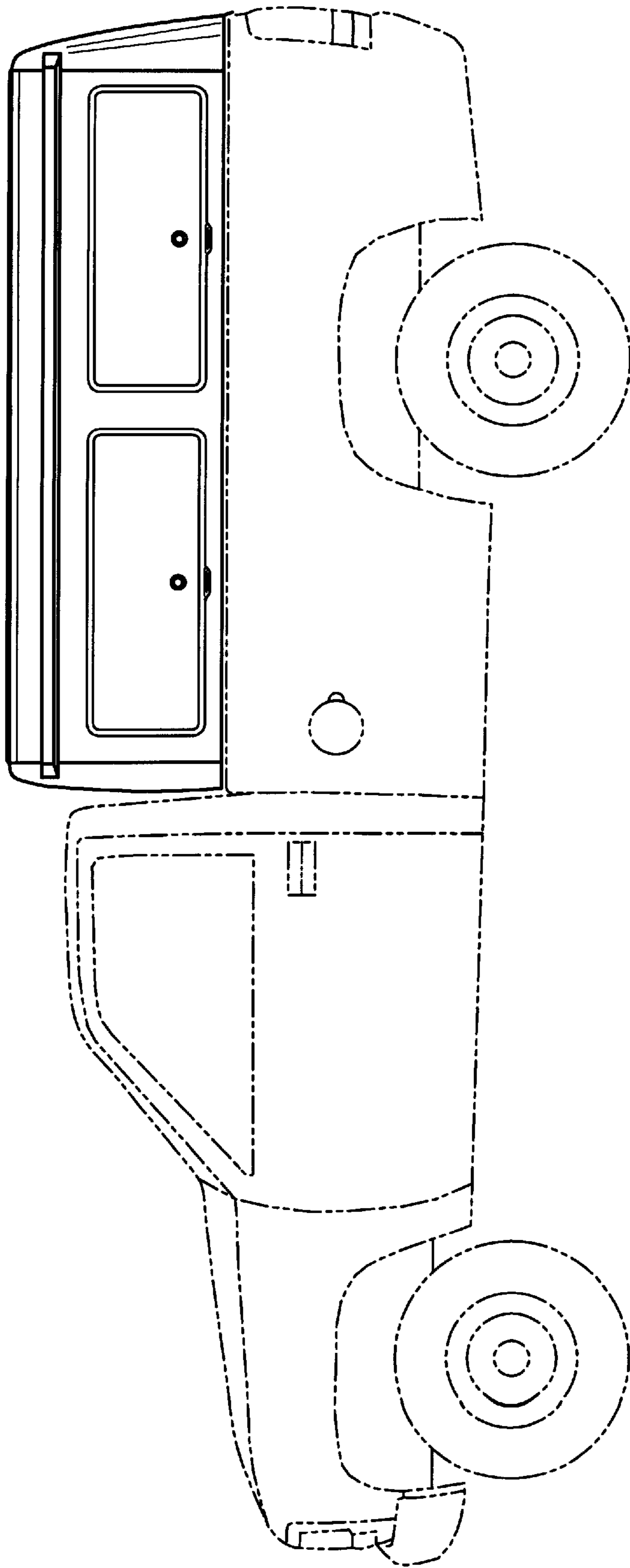

Fig. 2

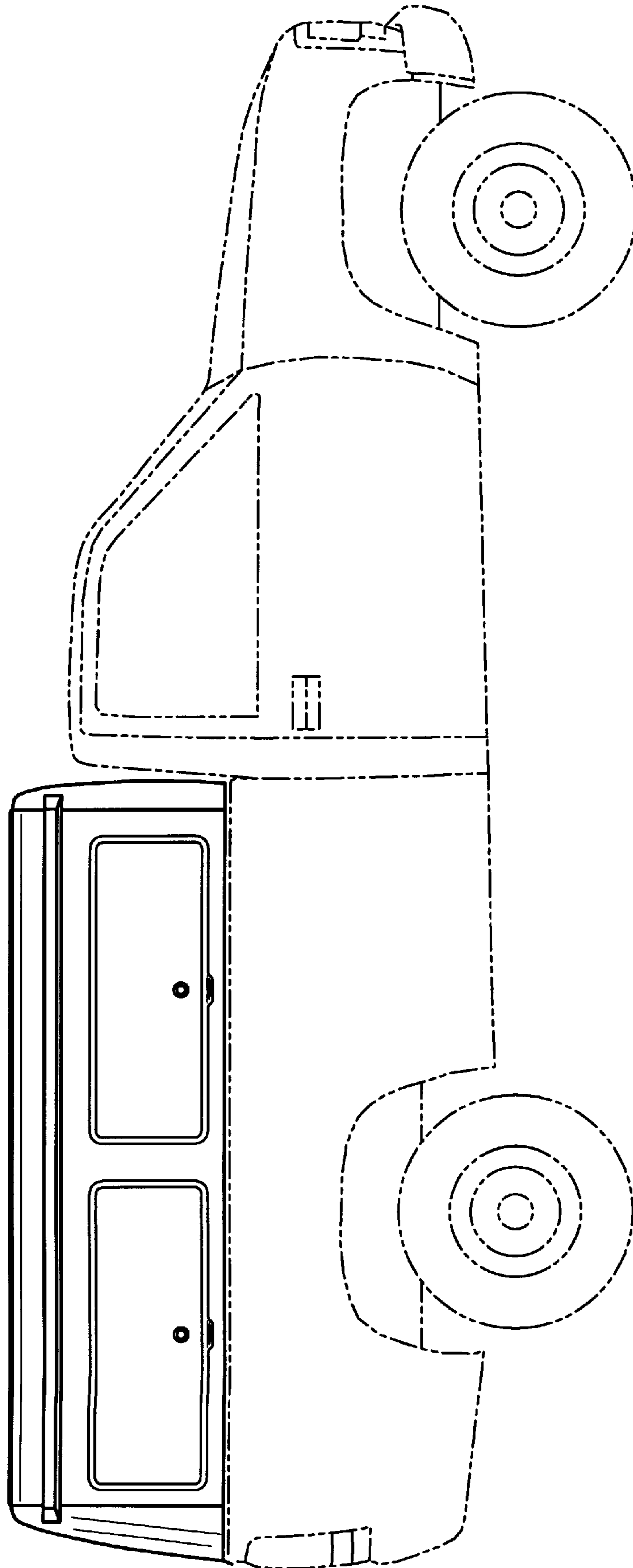

Fig. 3

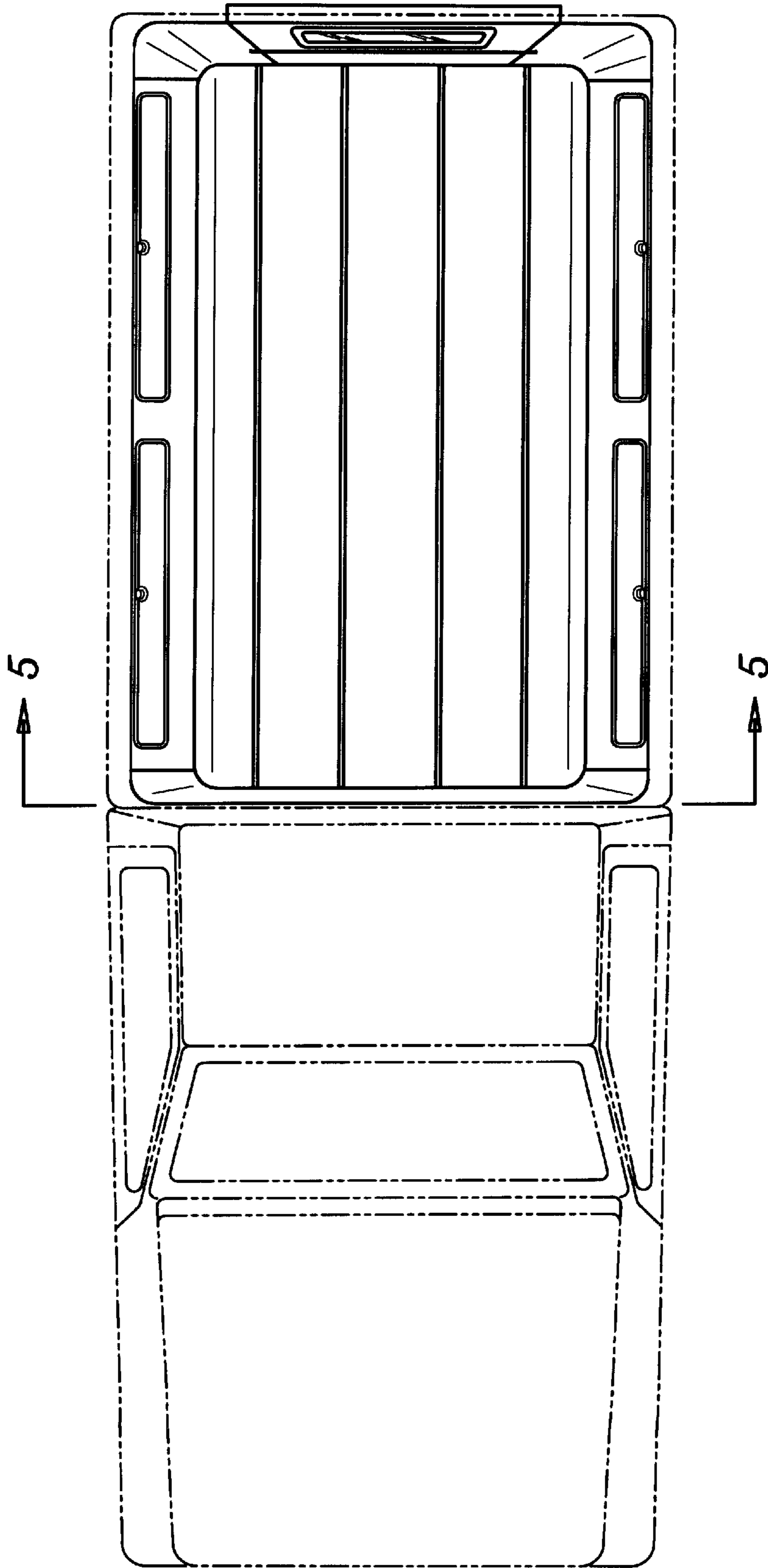

Fig. 4

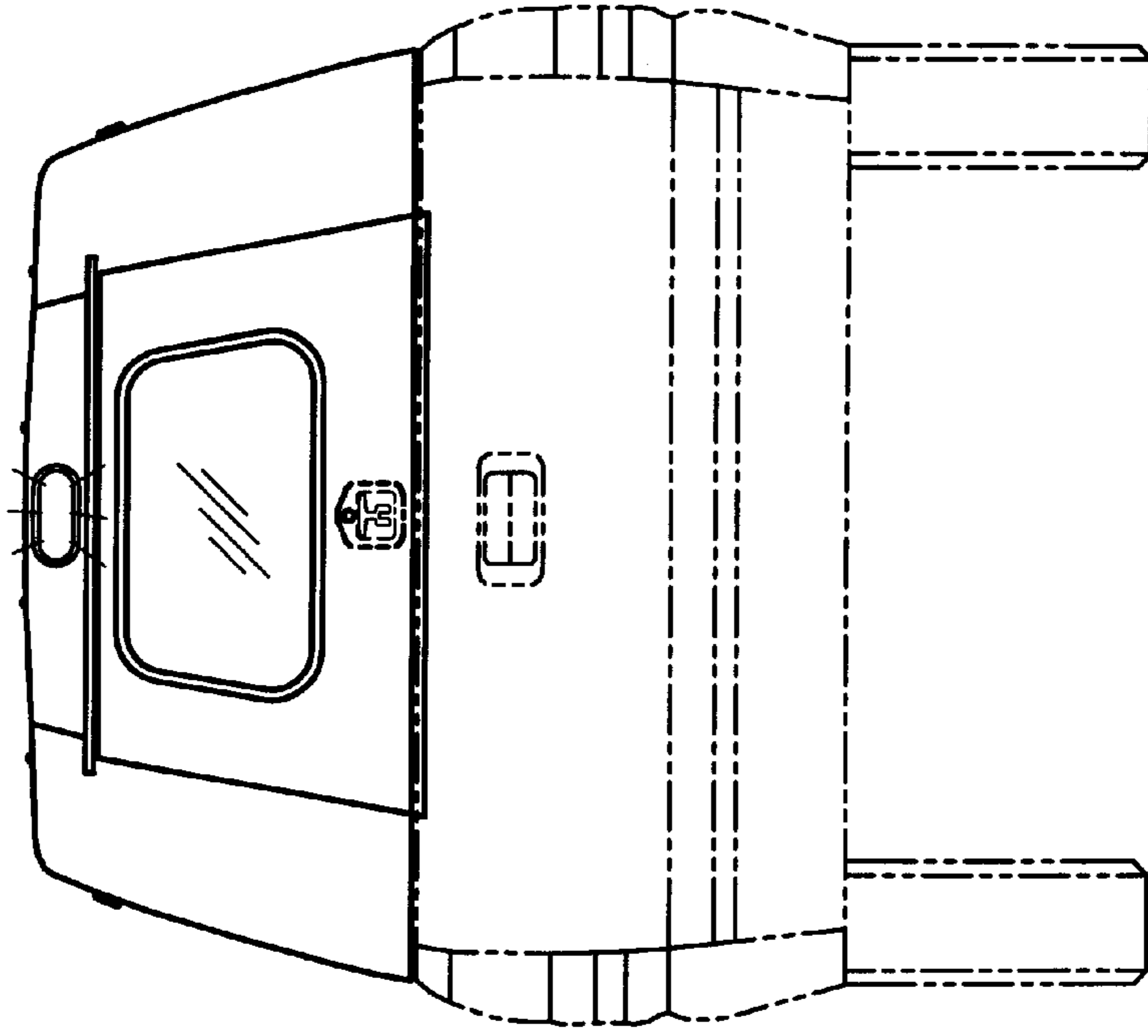

Fig. 6

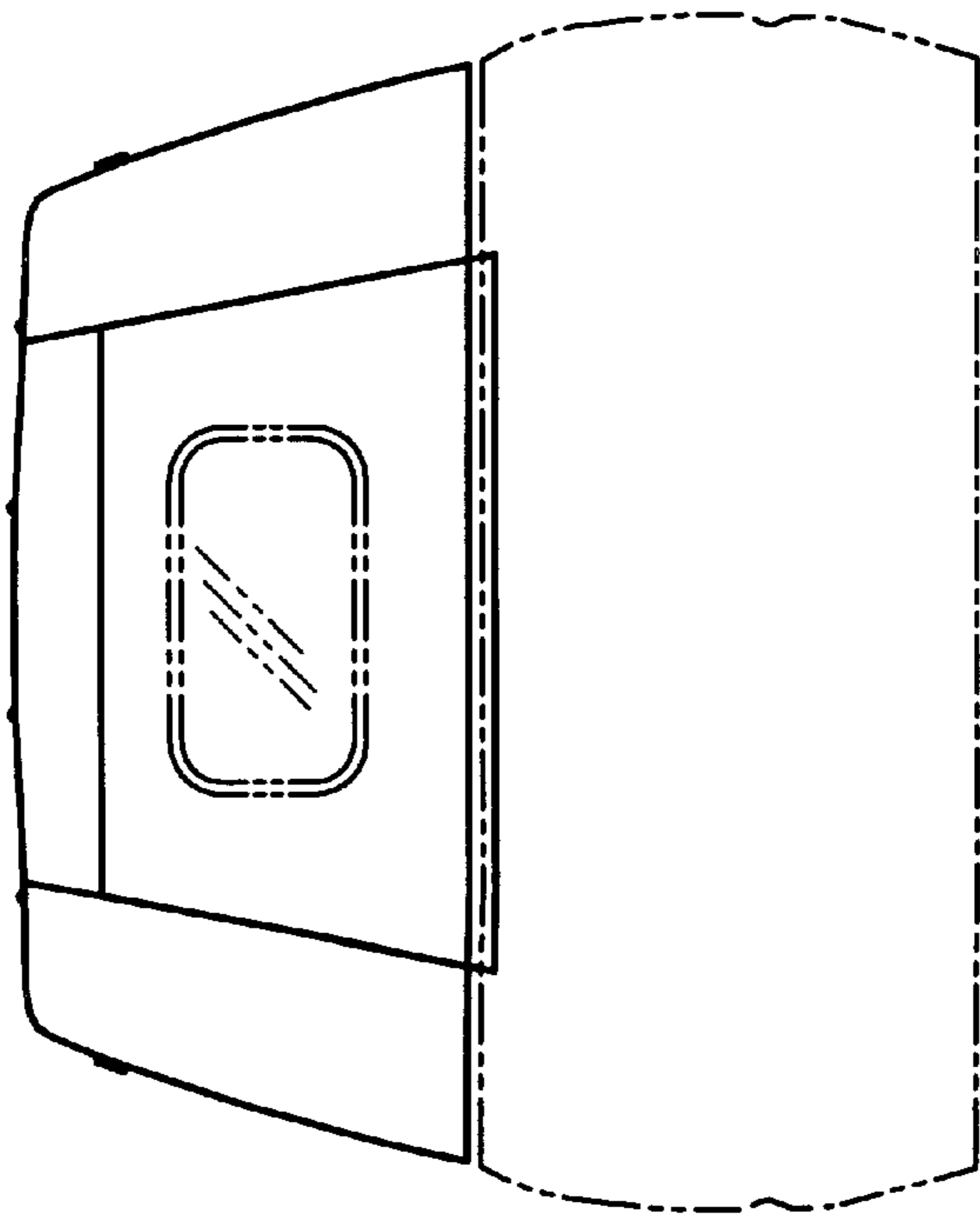

Fig. 5