



US00D430827S

# United States Patent [19]

**Baker**

[11] **Patent Number: Des. 430,827**

[45] **Date of Patent: \*\* Sep. 12, 2000**

[54] **TIRE TREAD**

[75] Inventor: **Christopher T. Baker**, Peninsula, Ohio

[73] Assignee: **Bridgestone/Firestone Research, Inc.**, Akron, Ohio

[\*\*] Term: **14 Years**

[21] Appl. No.: **29/116,196**

[22] Filed: **Dec. 28, 1999**

[51] **LOC (7) Cl.** ..... **12-15**

[52] **U.S. Cl.** ..... **D12/146**

[58] **Field of Search** ..... D12/134-152;  
152/209.1, 209.8, 209.12, 209.16, 209.28,  
902, 903

[56] **References Cited**

**U.S. PATENT DOCUMENTS**

D. 102,275	12/1936	Huebener	.....	D12/146
D. 284,178	6/1986	Kawabata et al.	.....	D12/147
D. 284,750	7/1986	Kawabata et al.	.....	D12/147
D. 287,955	1/1987	Hayakawa et al.	.....	D12/147
D. 291,874	9/1987	Hayakawa et al.	.....	D12/147
D. 316,991	5/1991	Graas	.....	D12/147
D. 322,950	1/1992	Overhoff et al.	.....	D12/147
D. 333,455	2/1993	Himuro et al.	.....	D12/147
D. 335,643	5/1993	Hino	.....	D12/147
D. 338,436	8/1993	Maxwell et al.	.....	D12/146
D. 344,050	2/1994	Overhoff et al.	.....	D12/147
D. 362,420	9/1995	Heinen et al.	.....	D12/147
D. 380,718	7/1997	Ratliff, Jr.	.....	D12/152

D. 387,720	12/1997	Ratliff, Jr.	.....	D12/147
D. 395,625	6/1998	Mori	.....	D12/147
D. 395,856	7/1998	Horie et al.	.....	D12/147
D. 402,598	12/1998	Marchand	.....	D12/146
D. 405,036	2/1999	Pung, Jr.	.....	D12/152
5,105,864	4/1992	Watanabe et al.	.....	152/209 R

*Primary Examiner*—Robert M. Spear  
*Attorney, Agent, or Firm*—Michael Sand; John M. Vasuta

[57] **CLAIM**

The ornamental design for a tire tread, as shown and described.

**DESCRIPTION**

FIG. 1 is a side perspective view of a tire tread showing my new design, it being understood that the tread pattern is repeated throughout the circumference of the tire tread, the opposite side being a mirror image thereof; FIG. 2 is a front elevational view thereof; FIG. 3 is a slightly reduced side elevational view of the right side thereof; FIG. 4 is a slightly reduced side elevational view of the left side thereof; and, FIG. 5 is an enlarged fragmentary front elevational view thereof.

The dark stippled surface shading represents the recessed portion of the tread grooves, having a depth as best shown in FIG. 2; the broken lines defining the tire sidewall and inner bead and the peripheral boundary between the tire tread and sidewall are for illustrative purposes only and form no part of the claimed design.

**1 Claim, 5 Drawing Sheets**

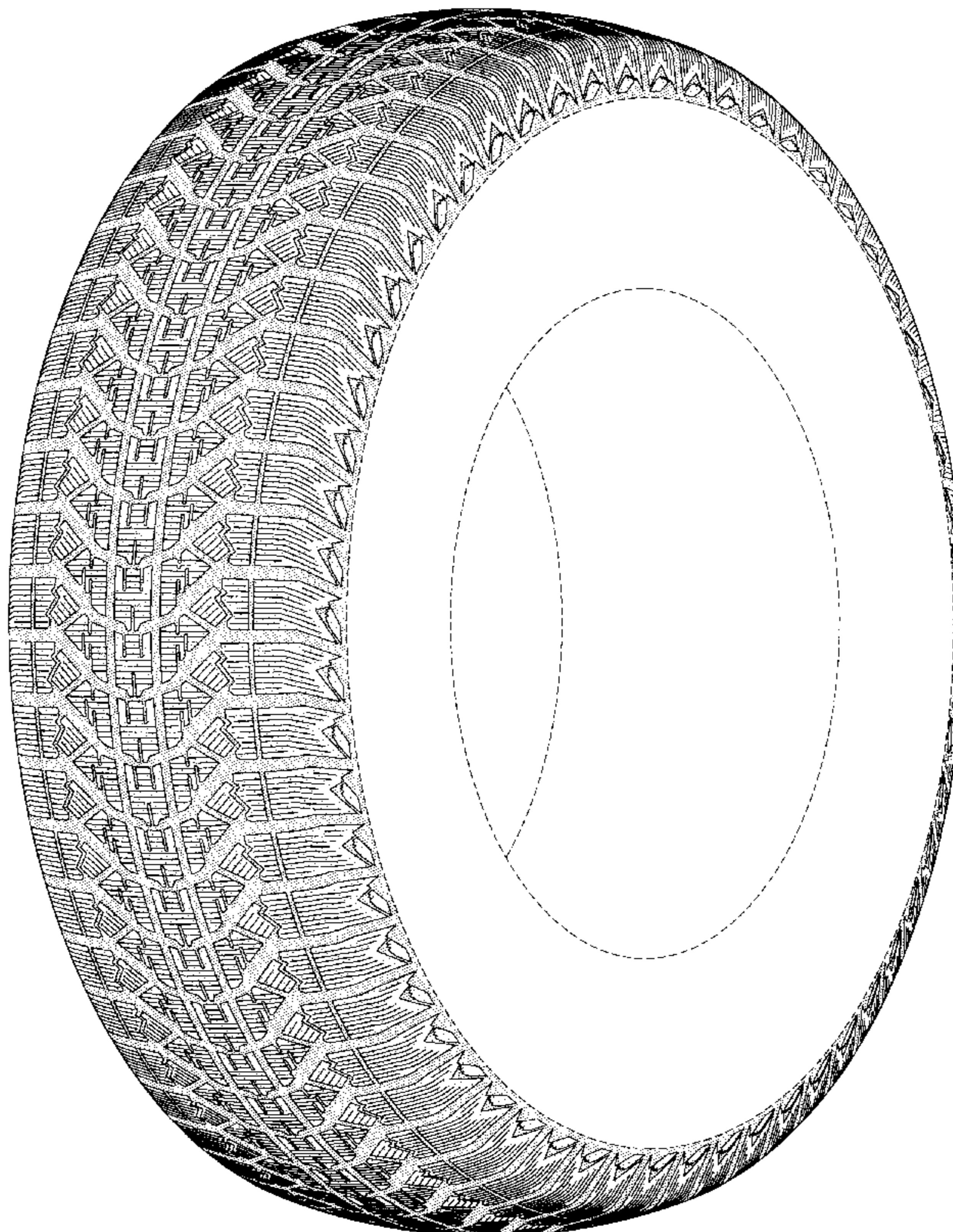

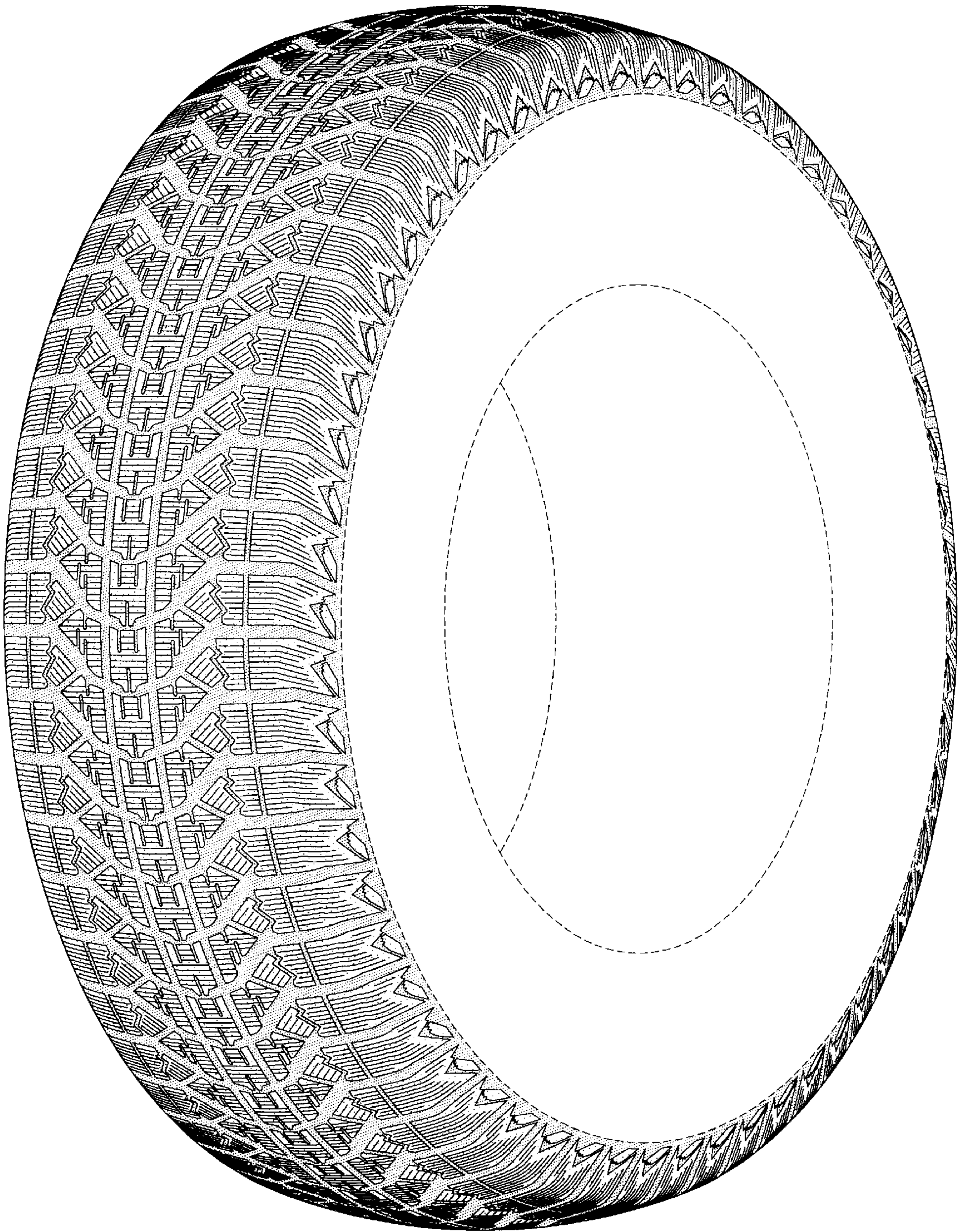

FIG-1

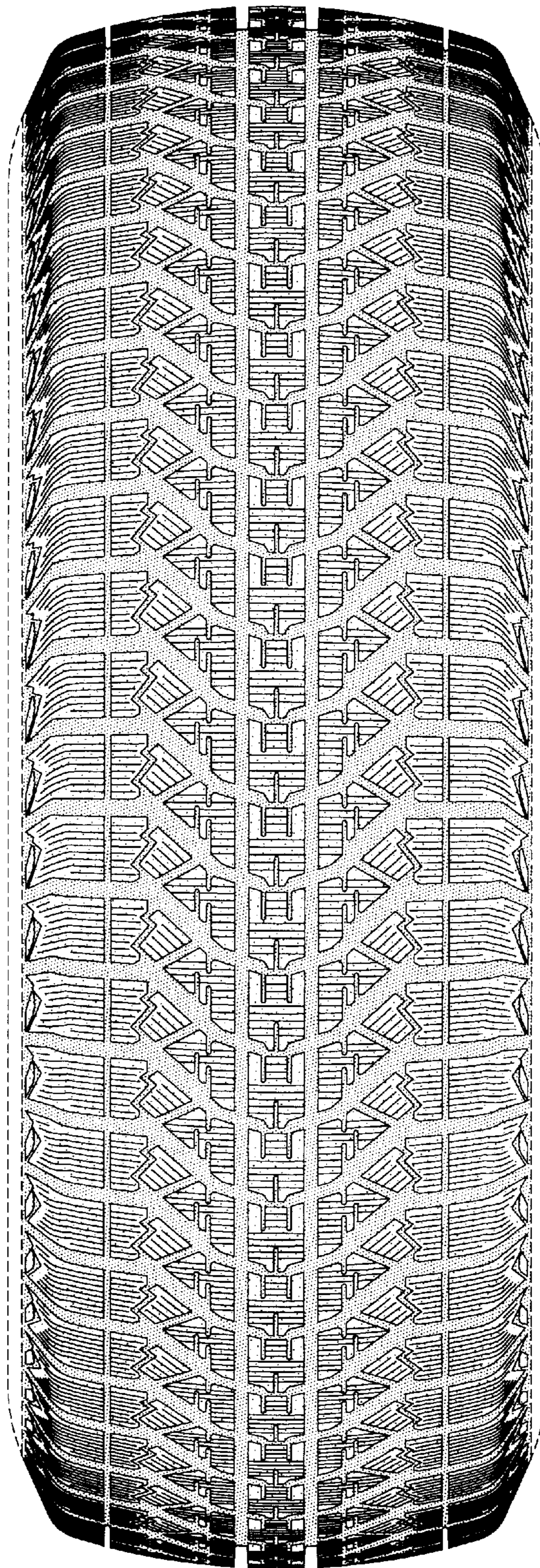

FIG-2

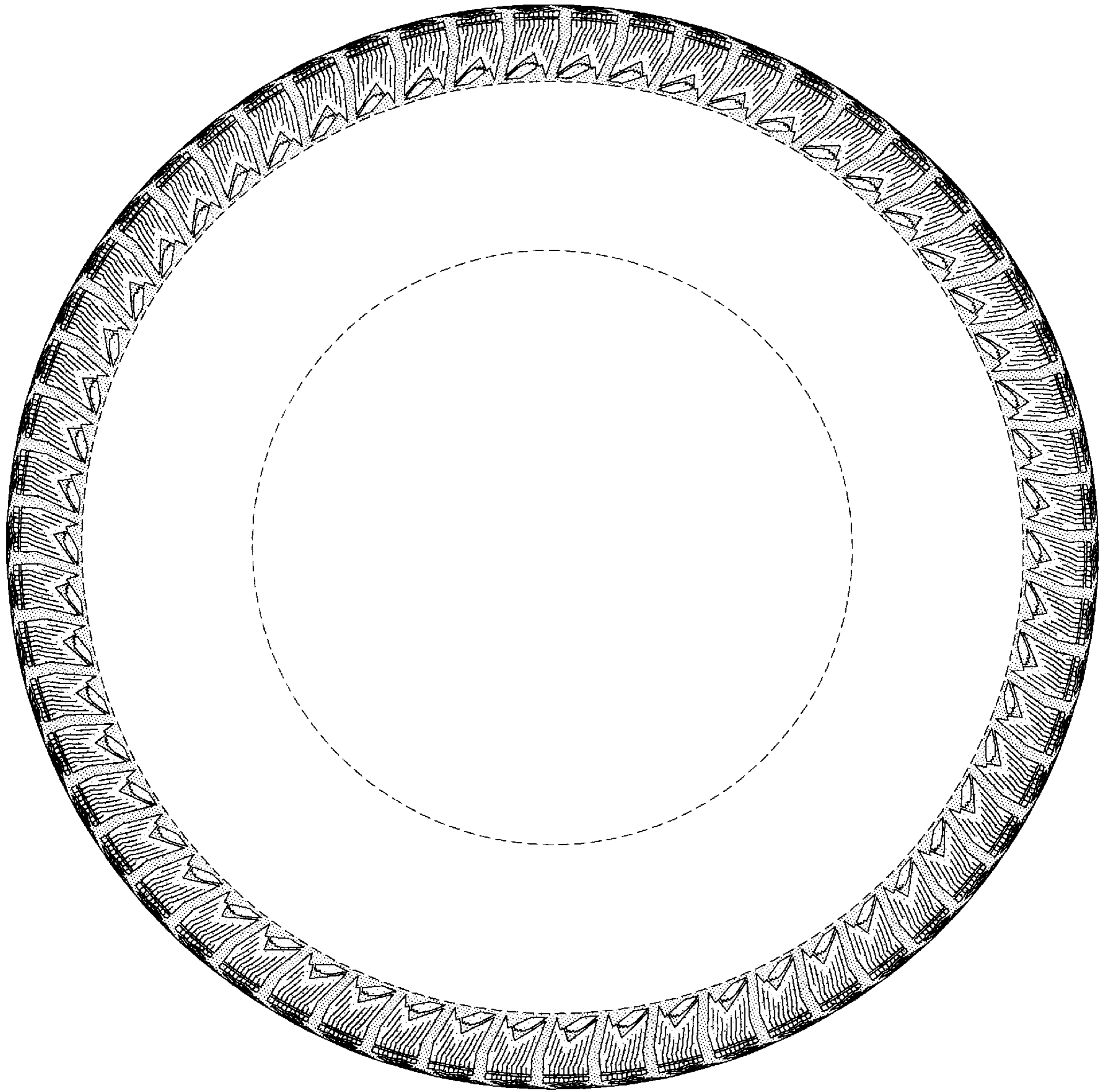

FIG-3

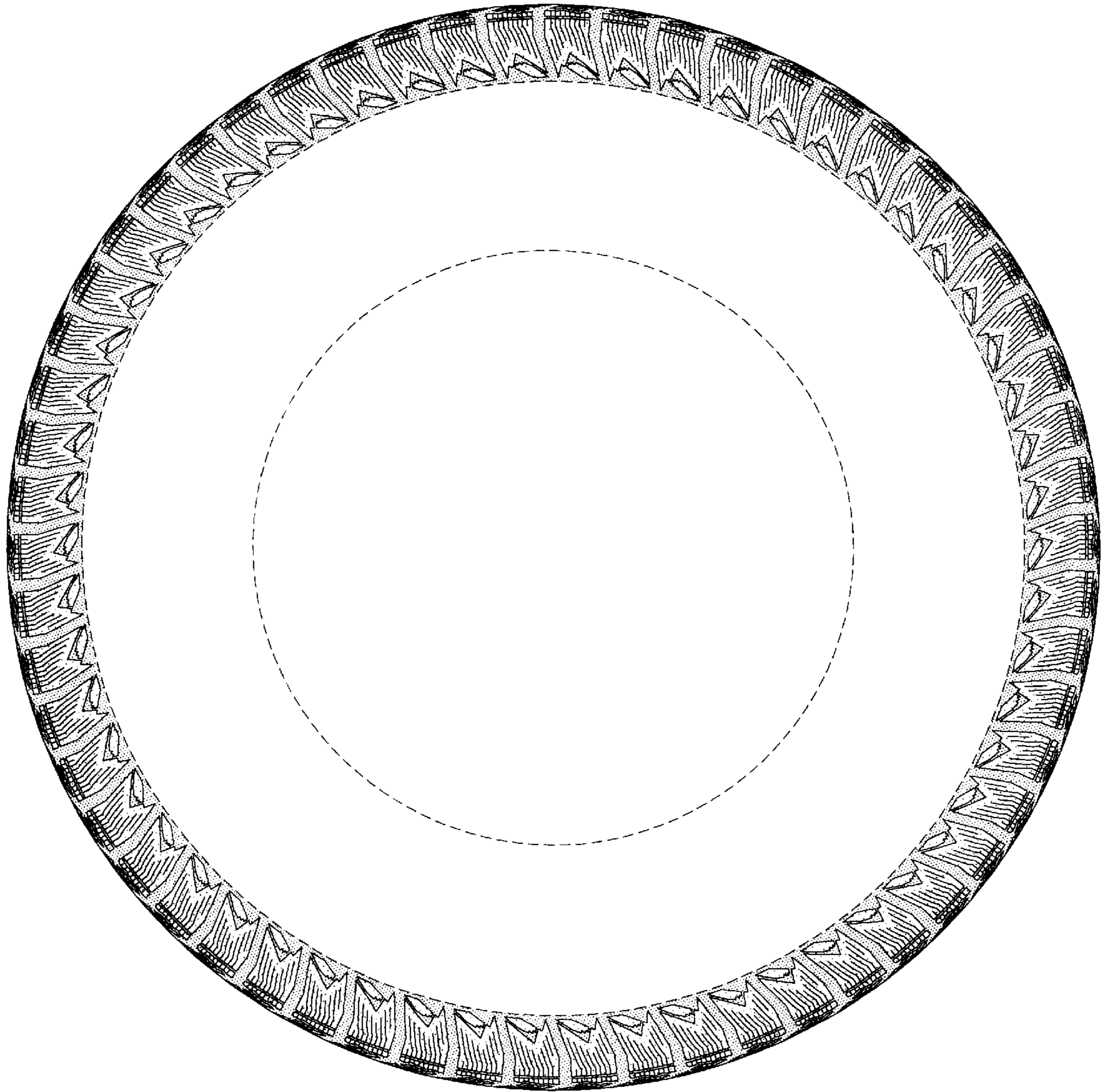

FIG-4

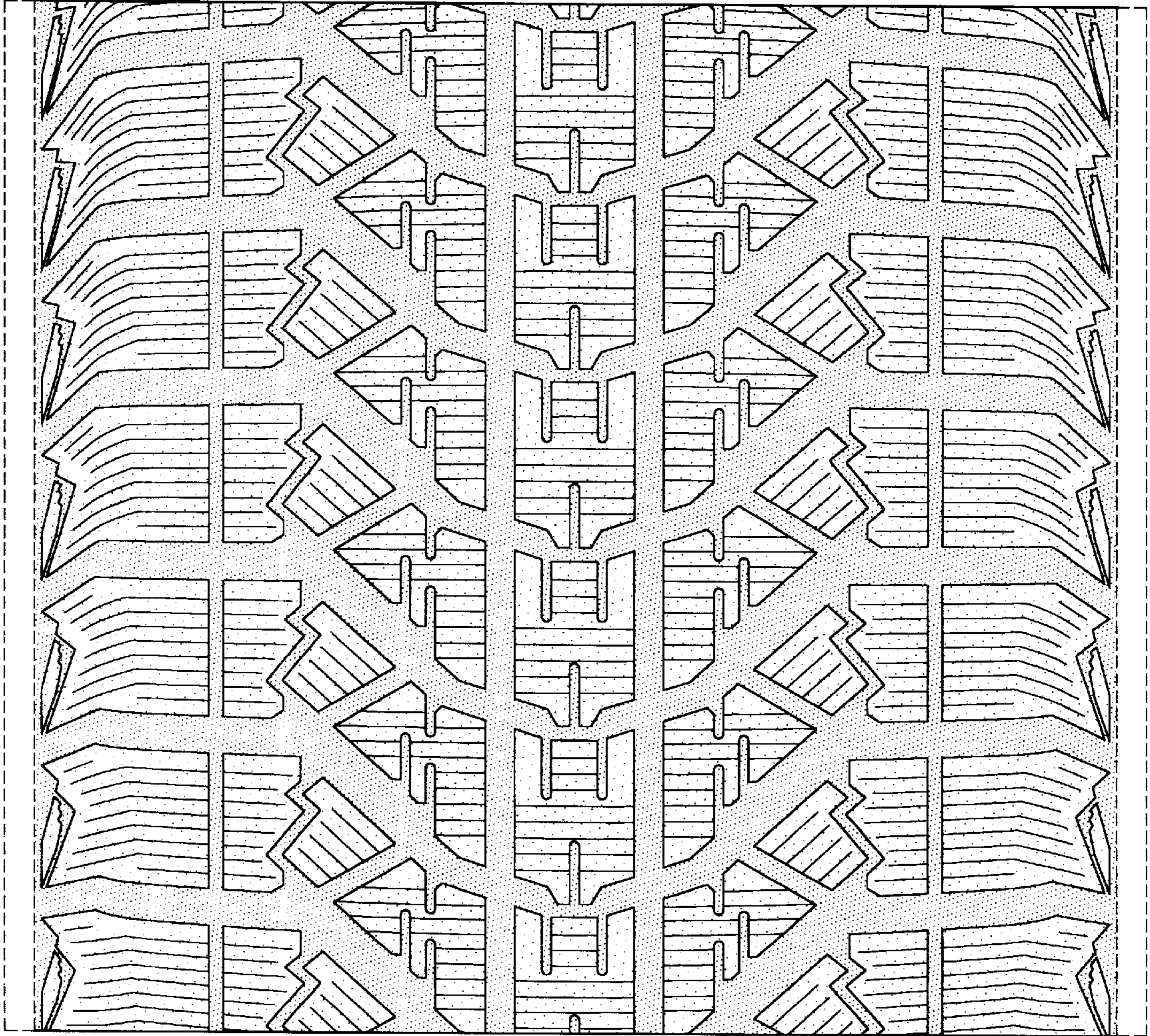

FIG-5