



US00D430820S

# United States Patent [19]

**Chergosky et al.**

[11] **Patent Number: Des. 430,820**

[45] **Date of Patent: \*\* Sep. 12, 2000**

[54] **VEHICLE BODY**

[75] Inventors: **William L. Chergosky; Kevin R. Verduyn**, both of Carlsbad; **Thomas G. Tremont**, San Diego, all of Calif.; **K. Neil Walling**, Leonard, Mich.

[73] Assignee: **DaimlerChrysler Corporation**, Auburn Hills, Mich.

[\*\*] Term: **14 Years**

[21] Appl. No.: **29/112,420**

[22] Filed: **Oct. 15, 1999**

[51] **LOC (7) Cl. .... 12-08**

[52] **U.S. Cl. .... D12/91**

[58] **Field of Search .... D12/90-92, 86; 296/185, 183**

[56] **References Cited**

**U.S. PATENT DOCUMENTS**

D. 336,266	6/1993	Hunter	.....	D12/98
D. 350,504	9/1994	Nixon	.....	D12/91
D. 352,485	11/1994	Creed et al.	.....	D12/98
D. 357,213	4/1995	Hunter et al.	.....	D12/98
D. 365,783	1/1996	Starr et al.	.....	D12/91
D. 373,979	9/1996	Starr et al.	.....	D12/98
D. 396,828	8/1998	Baccus et al.	.....	D12/91

D. 402,319	12/1998	Fu	.....	D12/91
D. 414,134	9/1999	Ikeda	.....	D12/91
D. 416,519	11/1999	Won et al.	.....	D12/91
D. 419,486	1/2000	Crain	.....	D12/91

*Primary Examiner*—Melody N. Brown  
*Attorney, Agent, or Firm*—Mark P. Calcaterra

[57] **CLAIM**

The ornamental design for a vehicle body, as shown and described.

**DESCRIPTION**

FIG. 1 is a front perspective view illustrating a vehicle body constructed in accordance with the teachings of the present invention.

FIG. 2 is a rear perspective view thereof.

FIG. 3 is a right side view thereof, it will be understood that the side opposite to that shown is a substantial mirror image thereof.

FIG. 4 is a front view thereof; and,

FIG. 5 is a rear view thereof.

It will be understood that the broken line showing of the wheels, tires and tailpipe throughout the drawings is for illustrative purposes only and forms no part of the subject invention. It will further be understood that the top is plain and unornamented.

**1 Claim, 4 Drawing Sheets**

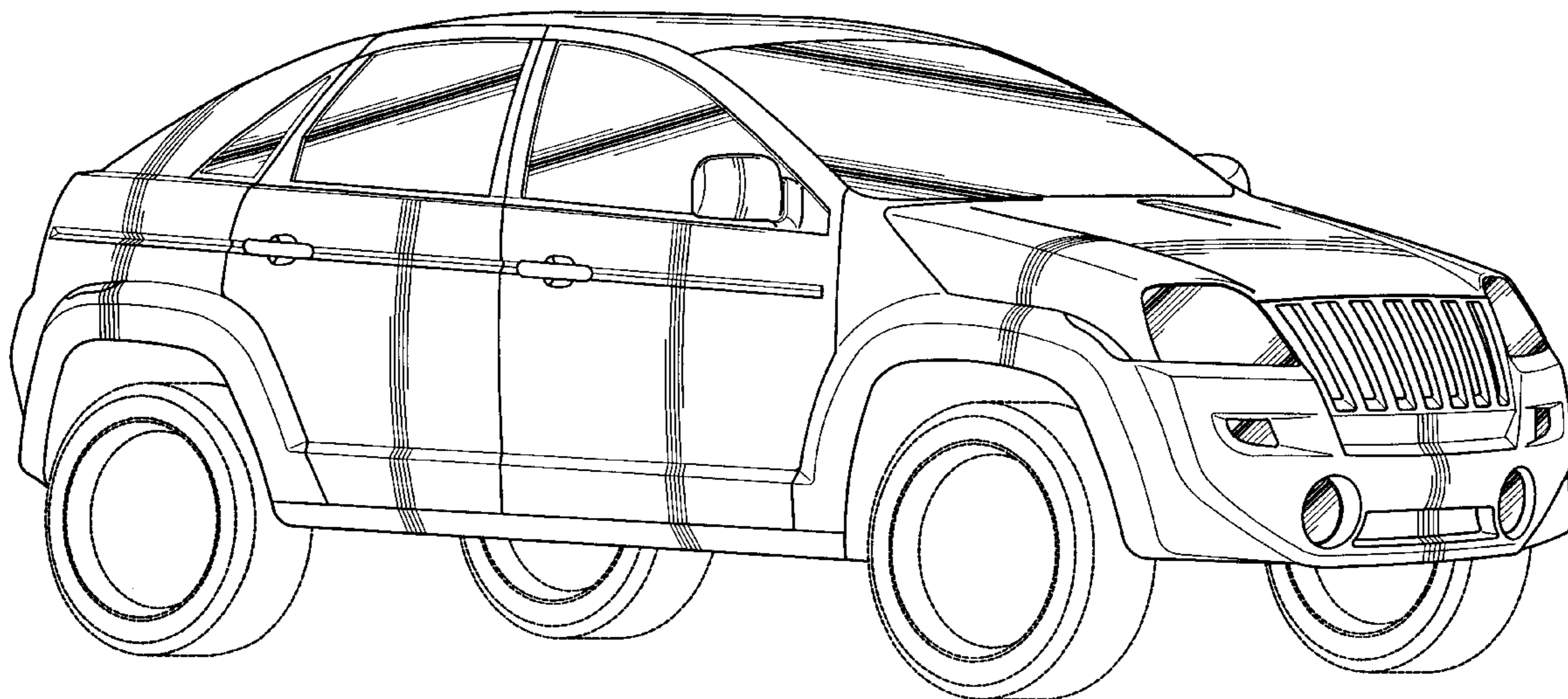

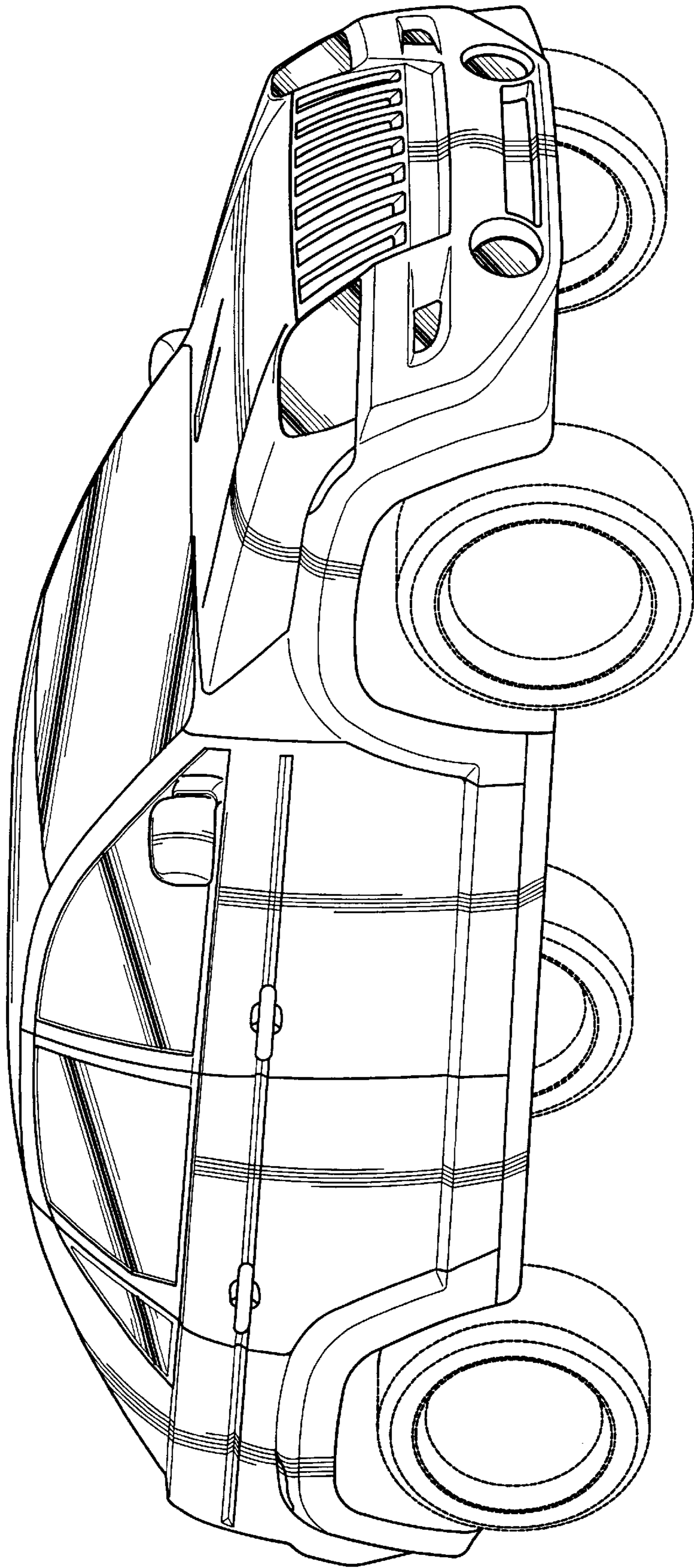

Figure - 1

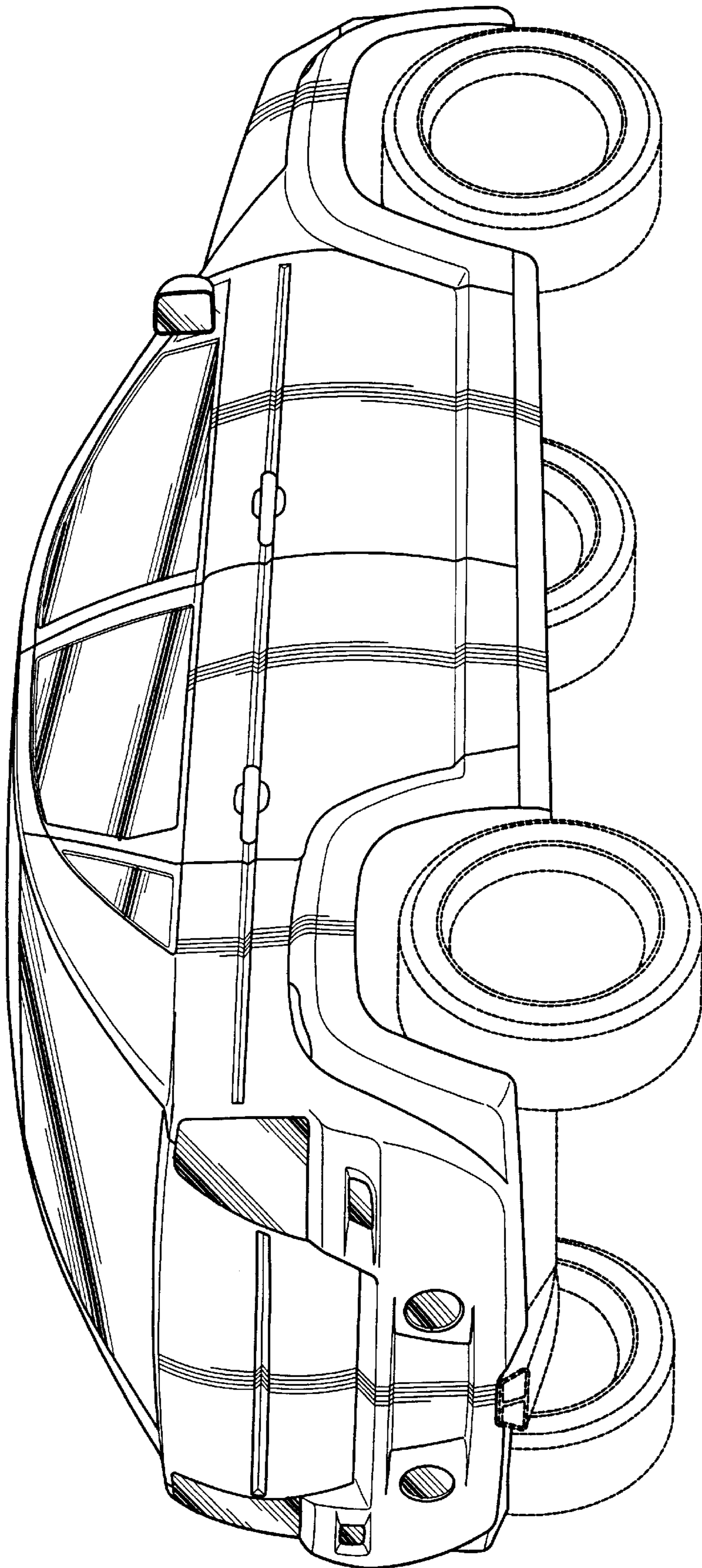

Figure - 2

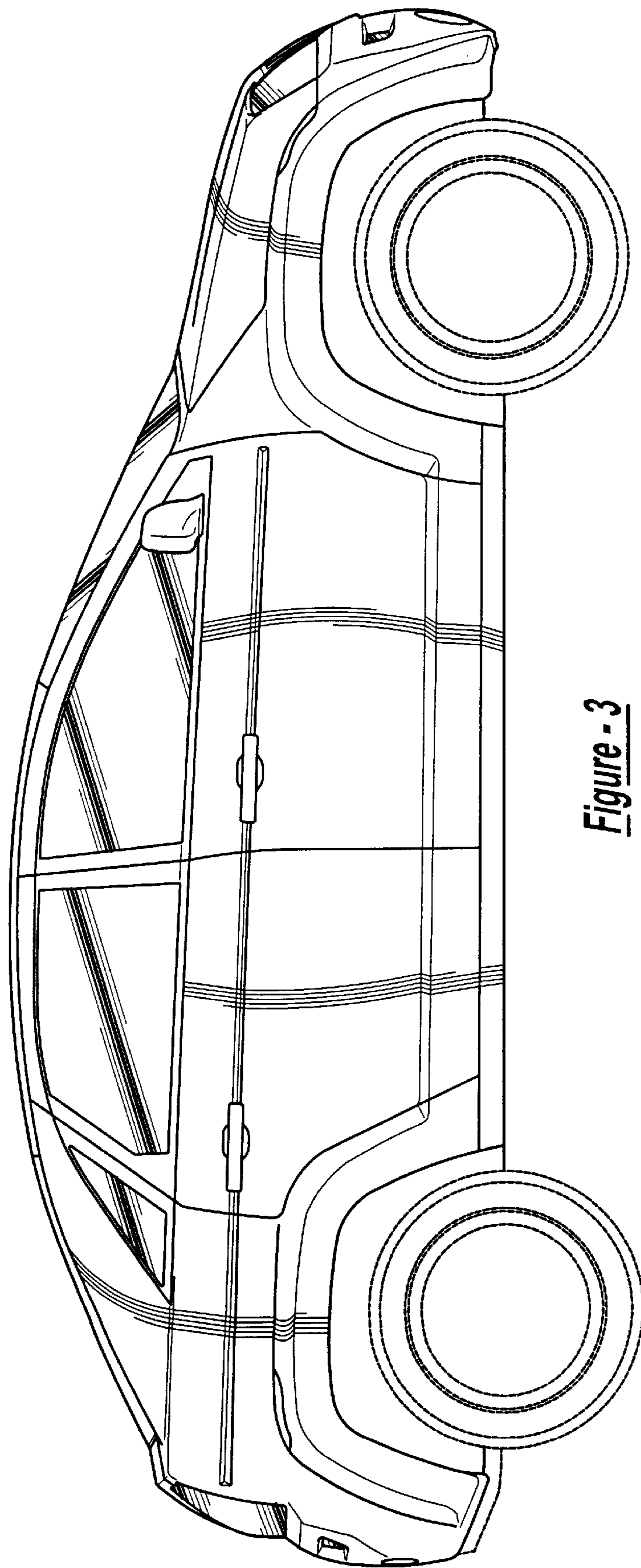

Figure - 3

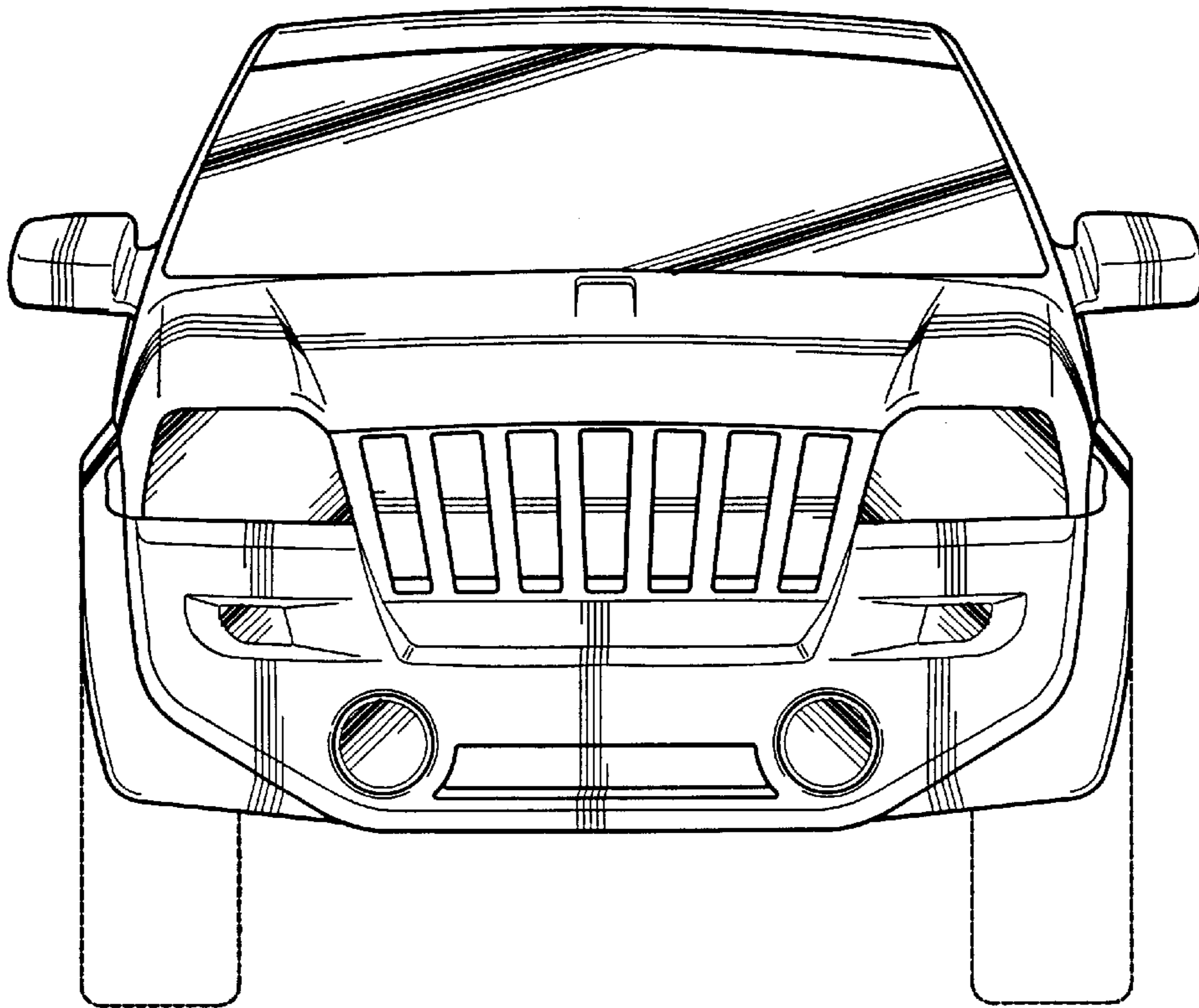

Figure - 4

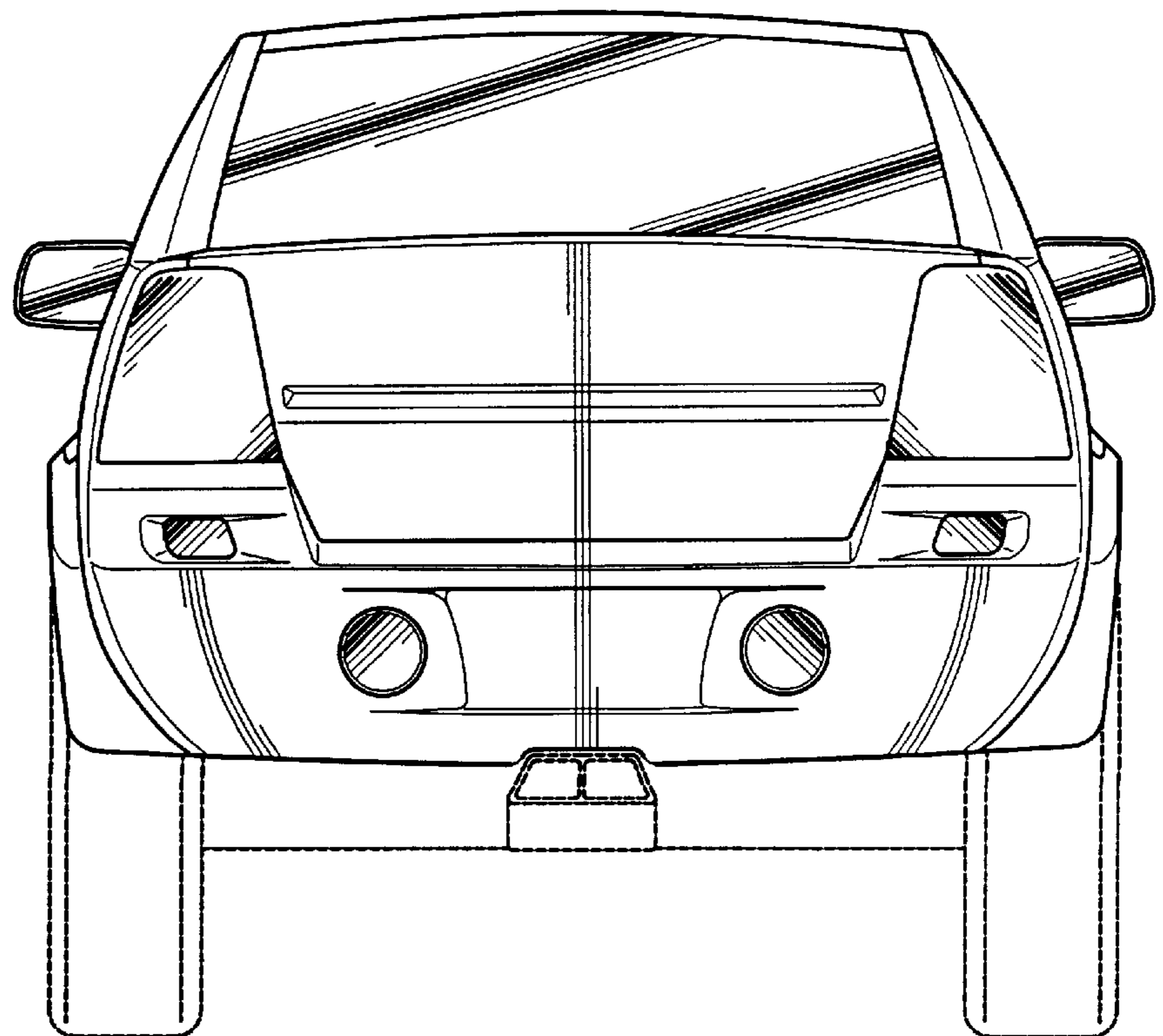

Figure - 5