



US00D430530S

United States Patent [19]
Milde, Jr.

[11] **Patent Number: Des. 430,530**
[45] **Date of Patent: ** Sep. 5, 2000**

[54] **PERSONAL AIR TRANSPORT**
[76] Inventor: **Karl F. Milde, Jr.**, 752 Union Valley Rd., Mahopac, N.Y. 10541
[**] Term: **14 Years**
[21] Appl. No.: **29/115,255**
[22] Filed: **Dec. 9, 1999**

4,807,830 2/1989 Horton 244/12.2
5,152,478 10/1992 Cycon et al. 244/12.2
5,653,404 8/1997 Ploshkin 244/12.2

Primary Examiner—Kay H. Chin

[57] **CLAIM**

The ornamental design for a personal air transport, as shown and described.

Related U.S. Application Data

[63] Continuation-in-part of application No. 09/247,163, Feb. 9, 1999, and application No. 29/103,093, Apr. 8, 1999, Pat. No. Des. 418,475.
[51] **LOC (7) Cl.** **12-07**
[52] **U.S. Cl.** **D12/325; D12/320**
[58] **Field of Search** D12/319, 320, D12/325, 326; 244/12.2, 23 C, 17.11, 39

DESCRIPTION

FIG. 1 is a top perspective view of a personal air transport showing my new design, the broken lines are for illustrative purposes only and form no part of the claimed design.
FIG. 2 is a side elevational view thereof, the opposite side view being a mirror image of that shown.
FIG. 3 is a top plan view thereof.
FIG. 4 is a bottom plan view thereof; and,
FIG. 5 is a front elevational view thereof.

[56] **References Cited**

U.S. PATENT DOCUMENTS

D. 312,067 11/1990 Walling D12/325

1 Claim, 4 Drawing Sheets

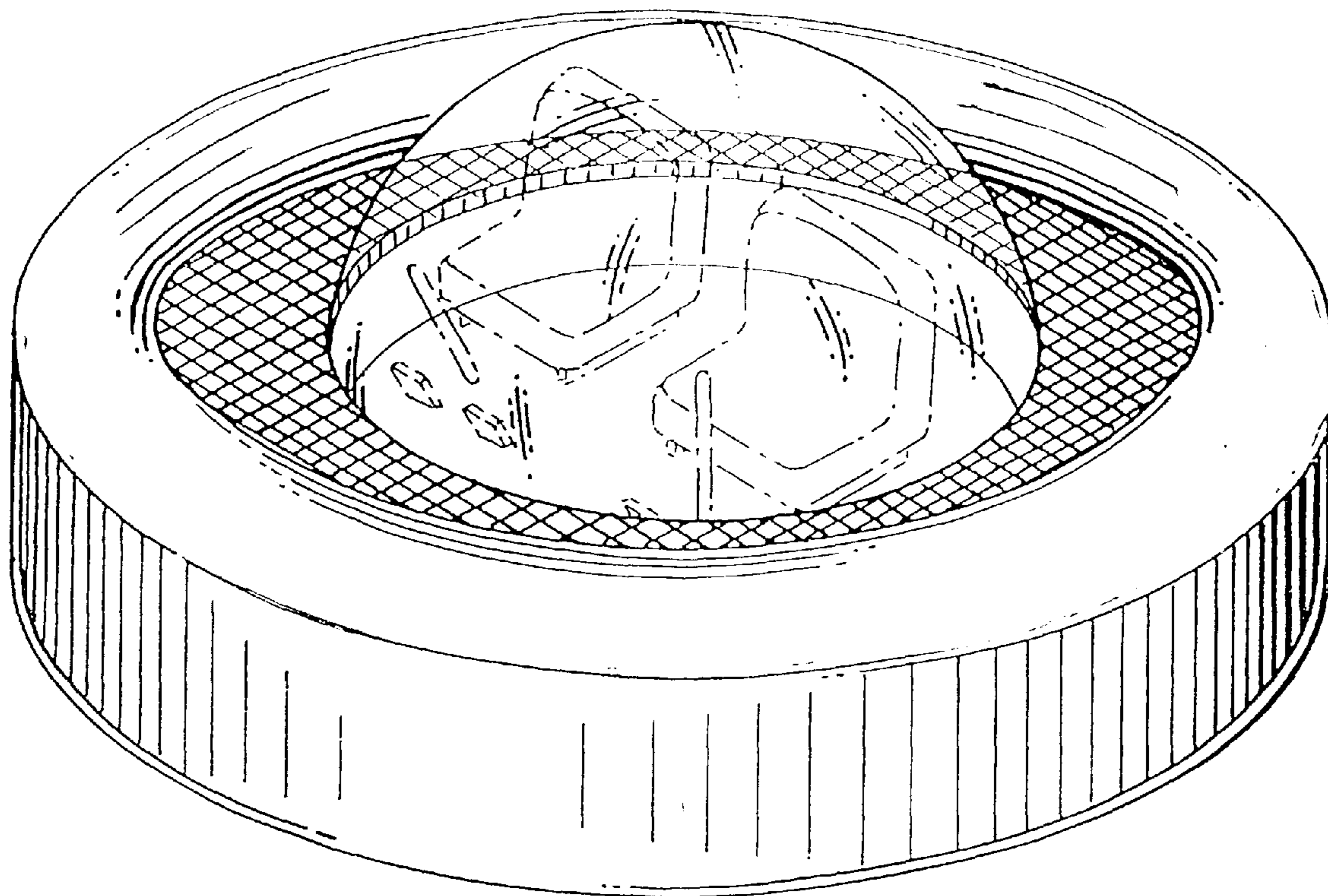

FIG.1

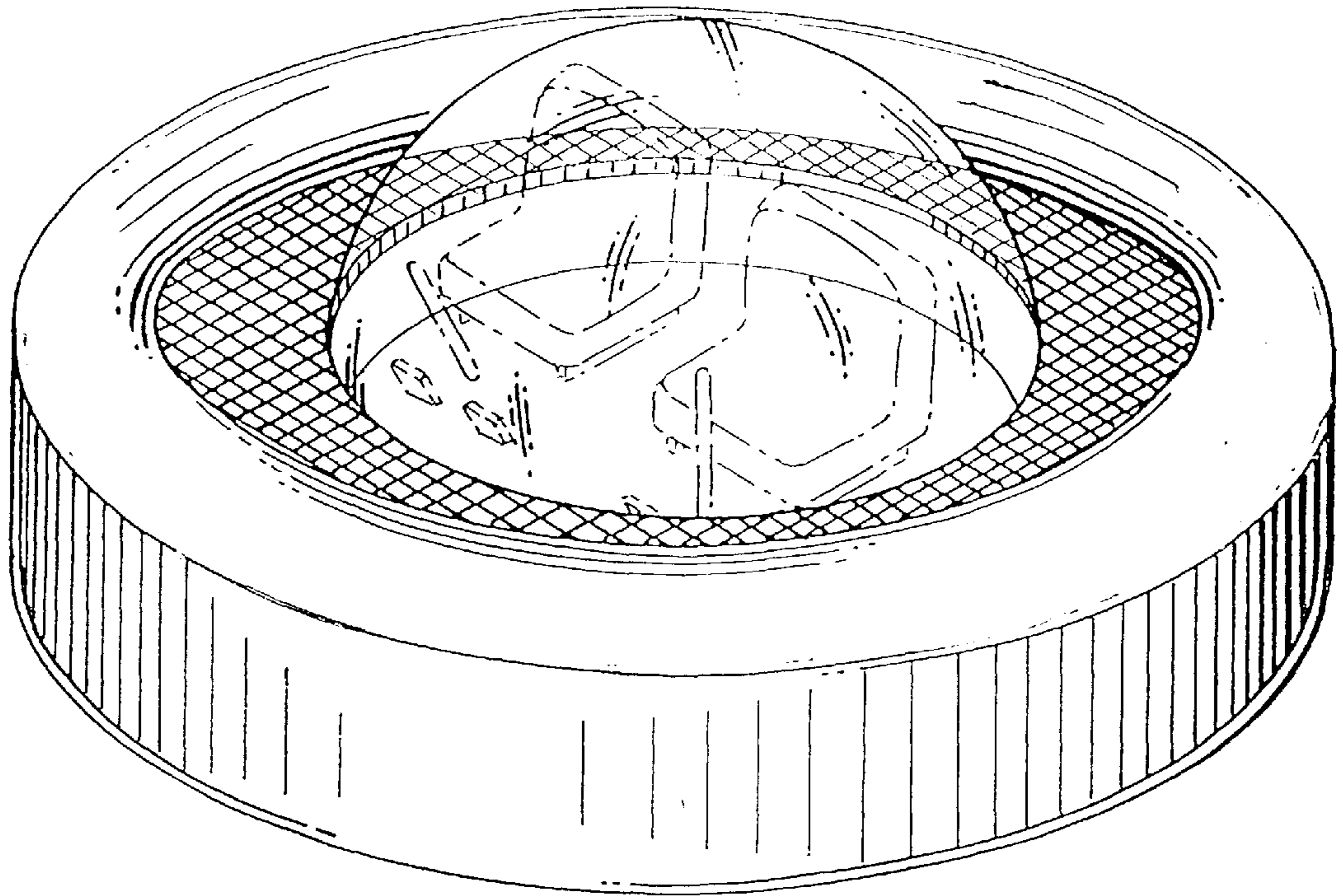
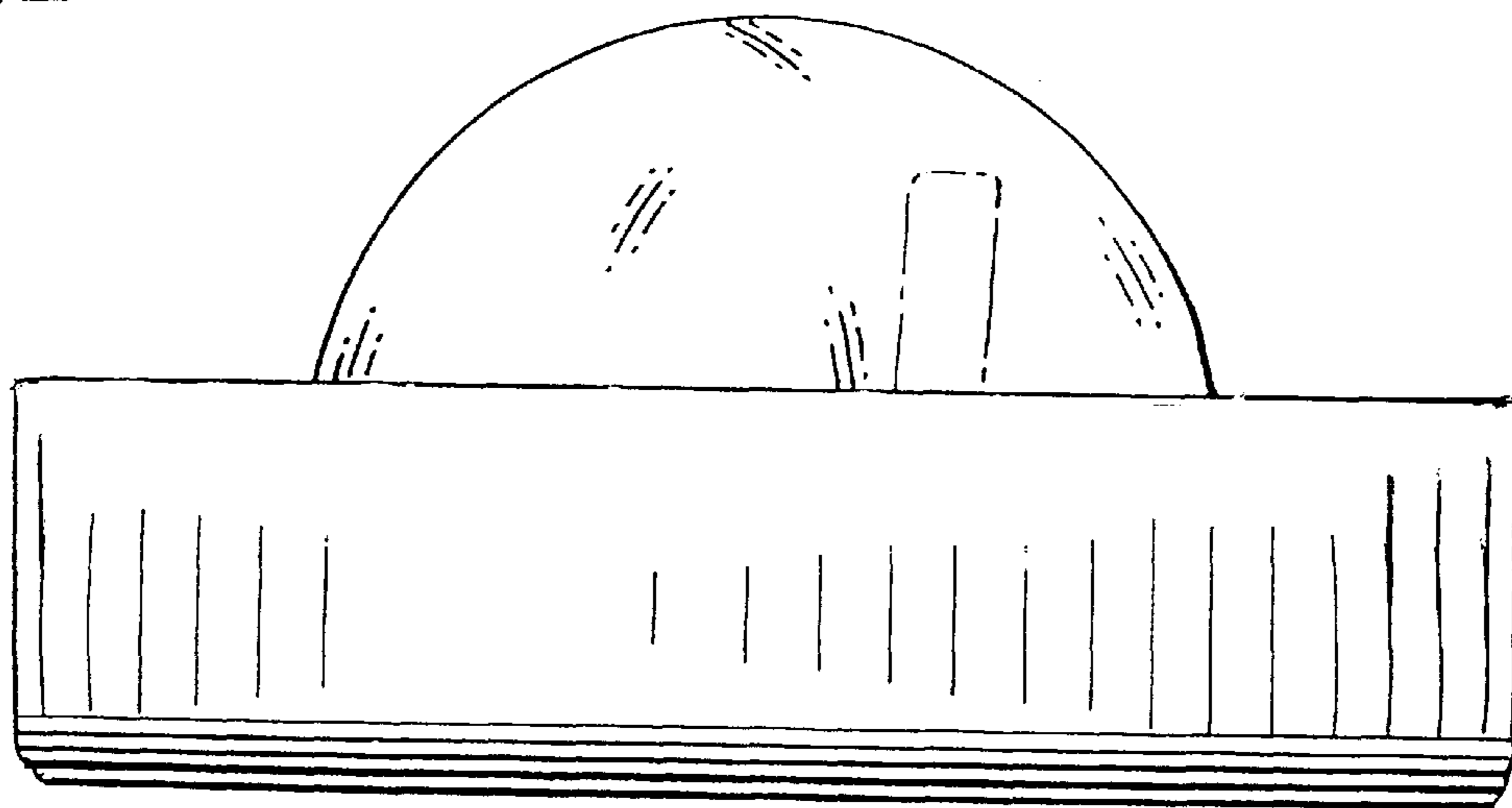

FIG.2



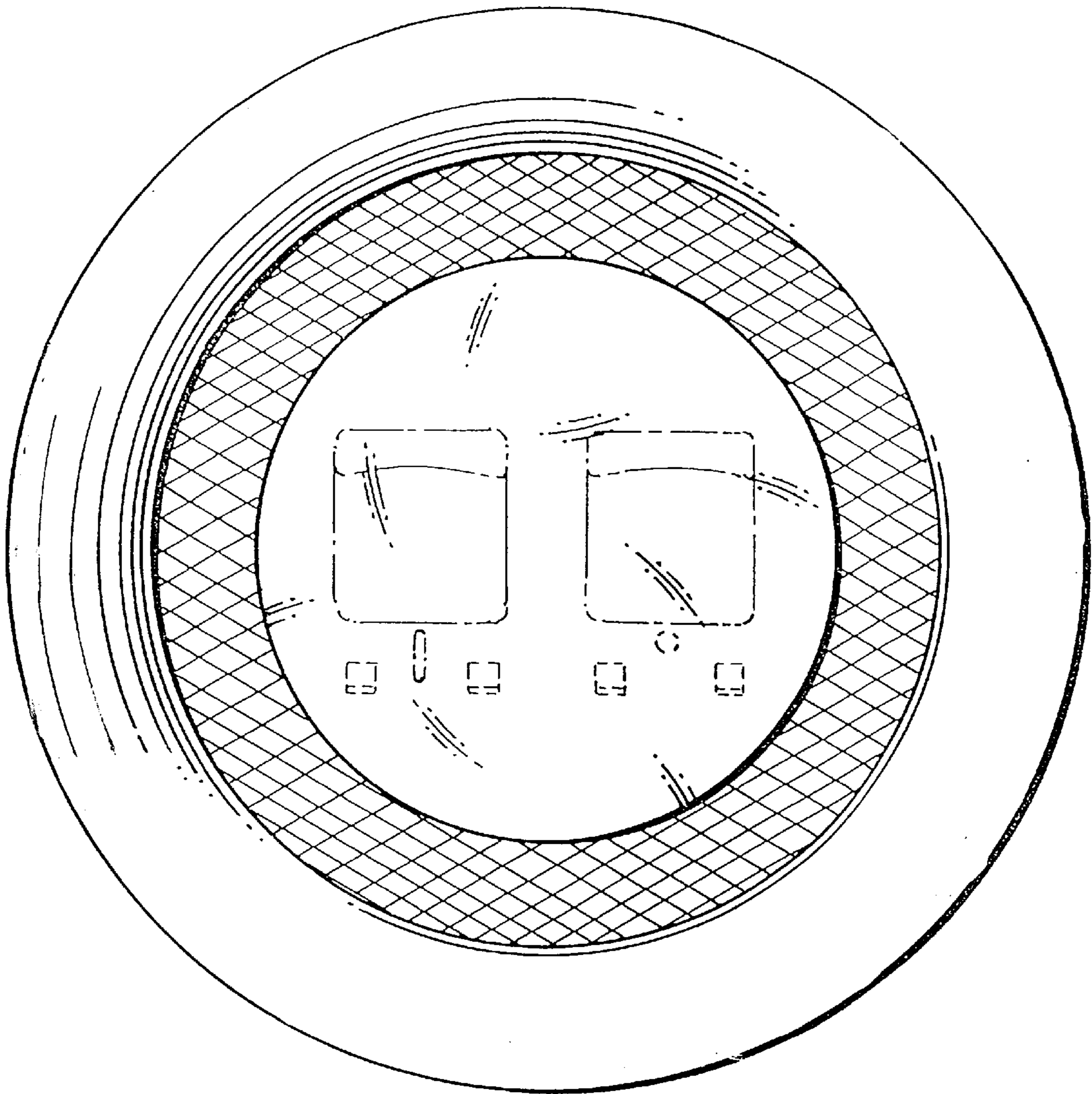

FIG.3

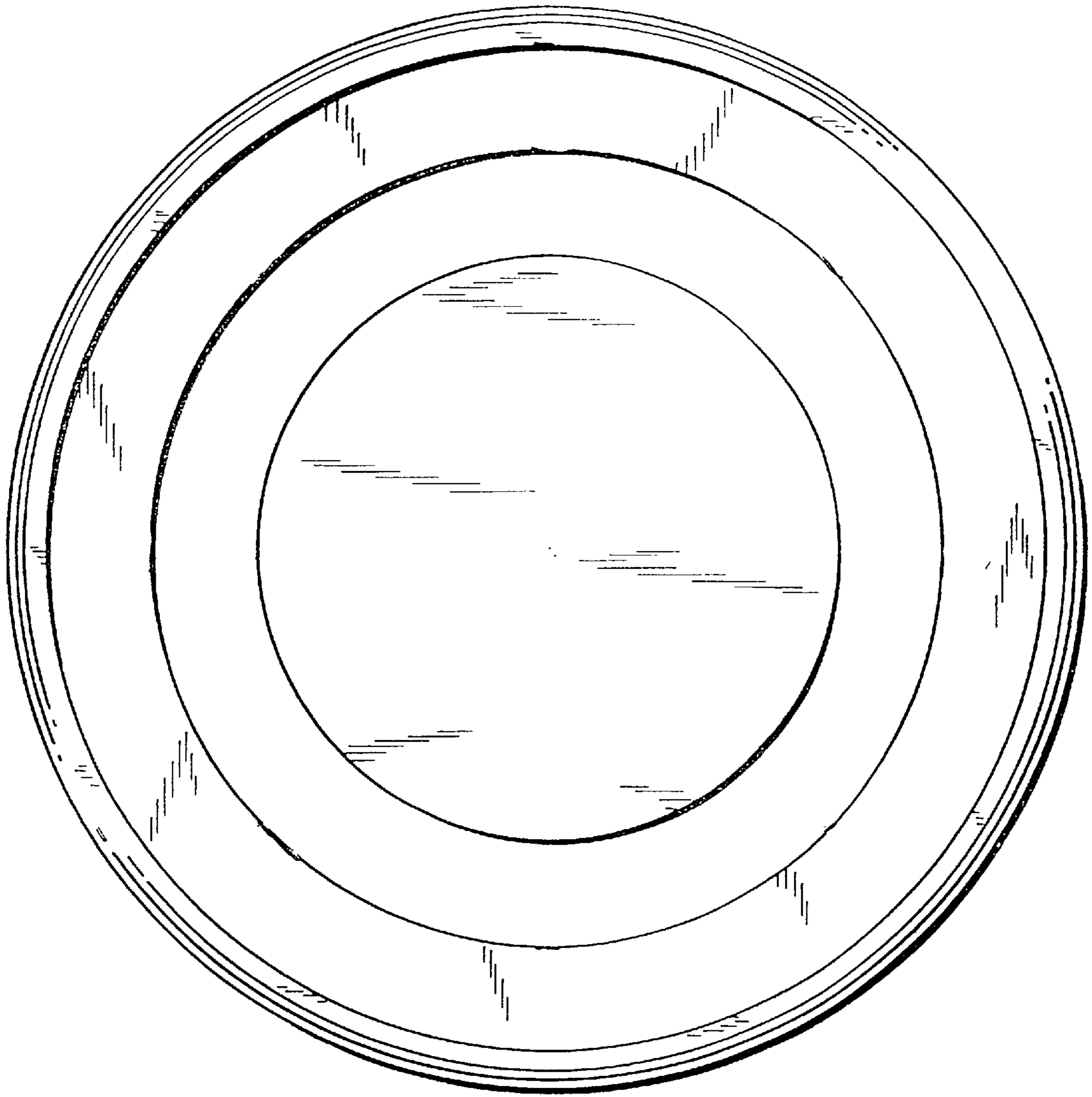

FIG.4

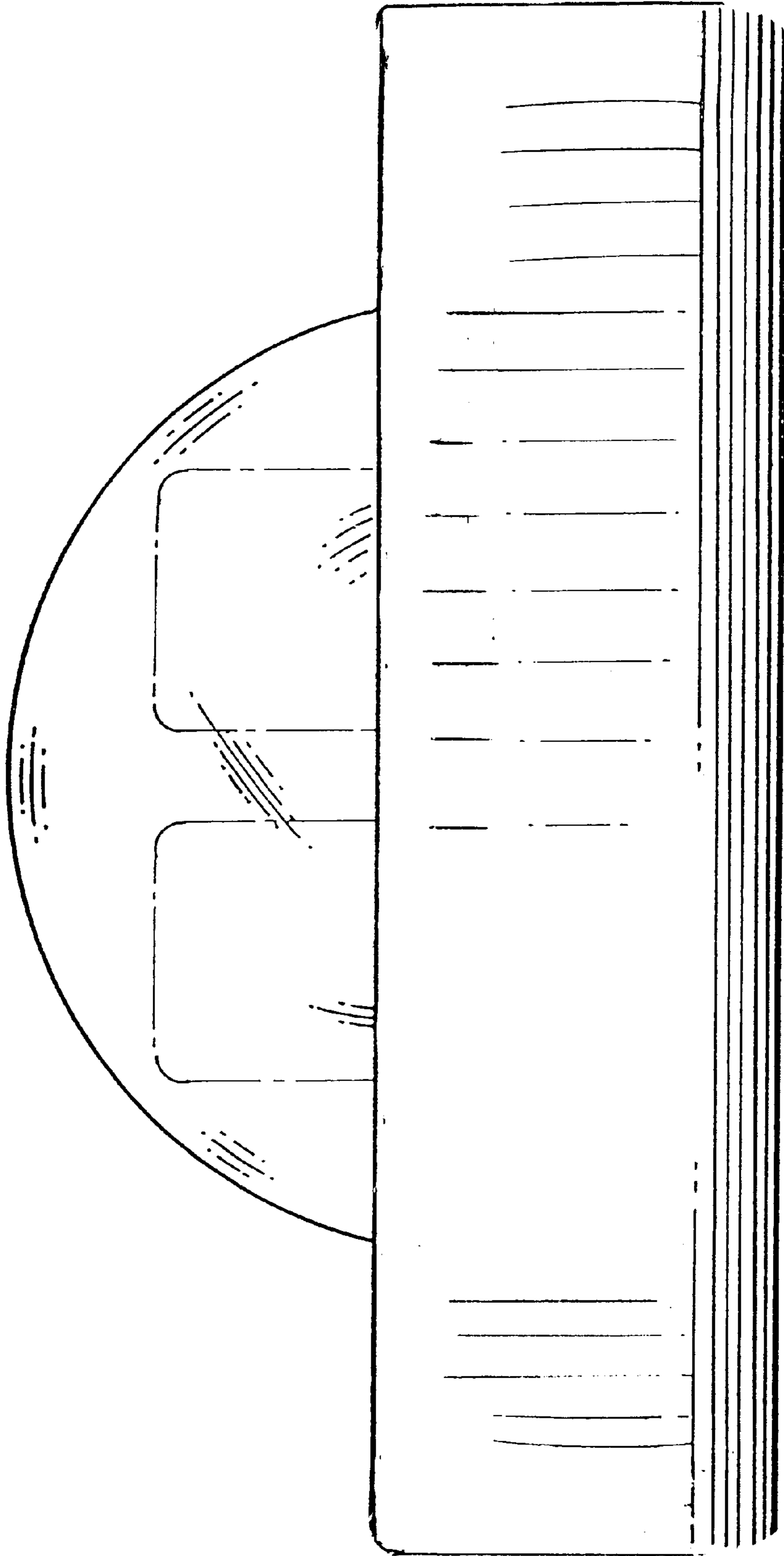

FIG.5