



US00D430521S

United States Patent [19]

[11] Patent Number: Des. 430,521

Kitamura et al.

[45] Date of Patent: ** Sep. 5, 2000

[54] RADIATOR GRILL OF A MOTOR VEHICLE

Attorney, Agent, or Firm—Sidley & Austin; Hugh A. Abrams

[75] Inventors: Eiji Kitamura, Hiroshima; Tsuyoshi Toyoda; Yutaka Shimazu, both of Aki-gun; Satoru Akana, Hiroshima, all of Japan

[57] CLAIM

The ornamental design for a radiator grill of a motor vehicle, as shown and described.

[73] Assignee: Mazda Motor Corporation, Hiroshima-ken, Japan

DESCRIPTION

[**] Term: 14 Years

[21] Appl. No.: 29/111,235

[22] Filed: Sep. 20, 1999

Related U.S. Application Data

[62] Division of application No. 29/097,179, Nov. 30, 1998.

[51] LOC (7) Cl. 12-16

[52] U.S. Cl. D12/163

[58] Field of Search D12/163, 169, D12/90-92; 180/68.6, 69.21, 68.1; 293/102, 115

FIG. 1 is a perspective view of a radiator grill of a motor vehicle showing our new design;

FIG. 2 is a front elevational view thereof;

FIG. 3 is a rear elevational view thereof;

FIG. 4 is a top plan view thereof;

FIG. 5 is a bottom plan view thereof;

FIG. 6 is a left side elevational view thereof;

FIG. 7 is a right side elevational view thereof;

FIG. 8 is an enlarged sectional view taken along the line 8—8 in FIG. 2;

FIG. 9 is an enlarged sectional end view taken along the line 9—9 in FIG. 2;

FIG. 10 is an enlarged sectional end view taken along the line 10—10 in FIG. 2;

FIG. 11 is a perspective view of a radiator grill of a motor vehicle showing a second embodiment of our new design;

FIG. 12 is a front elevational view of FIG. 11;

FIG. 13 is a rear elevational view of FIG. 11;

FIG. 14 is a top plan view of FIG. 11;

FIG. 15 is a bottom plan view of FIG. 11;

FIG. 16 is a left side elevational view of FIG. 11;

FIG. 17 is a right side elevational view of FIG. 11;

FIG. 18 is an enlarged sectional view of FIG. 11 taken along the line 18—18 in FIG. 12;

FIG. 19 is an enlarged sectional end view of FIG. 11 taken along the line 19—19 in FIG. 12; and,

FIG. 20 is an enlarged sectional end view of FIG. 11 taken along the line 20—20 in FIG. 12.

The portion of the radiator grill shown in broken lines is for illustrative purpose only and forms no part of the claimed design.

[56] References Cited

U.S. PATENT DOCUMENTS

D. 307,124	4/1990	Hayashi et al.	D12/163
D. 312,606	12/1990	Guelfi et al.	D12/163
D. 361,968	9/1995	Oyana	D12/163
D. 366,859	2/1996	Davis, Jr.	D12/163
D. 400,386	11/1998	Reynard et al.	D12/163
D. 403,285	12/1998	Abalos et al.	D12/163
D. 404,697	1/1999	Seltavuori	D12/163
D. 411,493	1/1999	Davis, Jr.	D12/163

FOREIGN PATENT DOCUMENTS

895261	3/1994	Japan .
896204	4/1994	Japan .
896282	4/1994	Japan .

Primary Examiner—Melody N. Brown

1 Claim, 14 Drawing Sheets

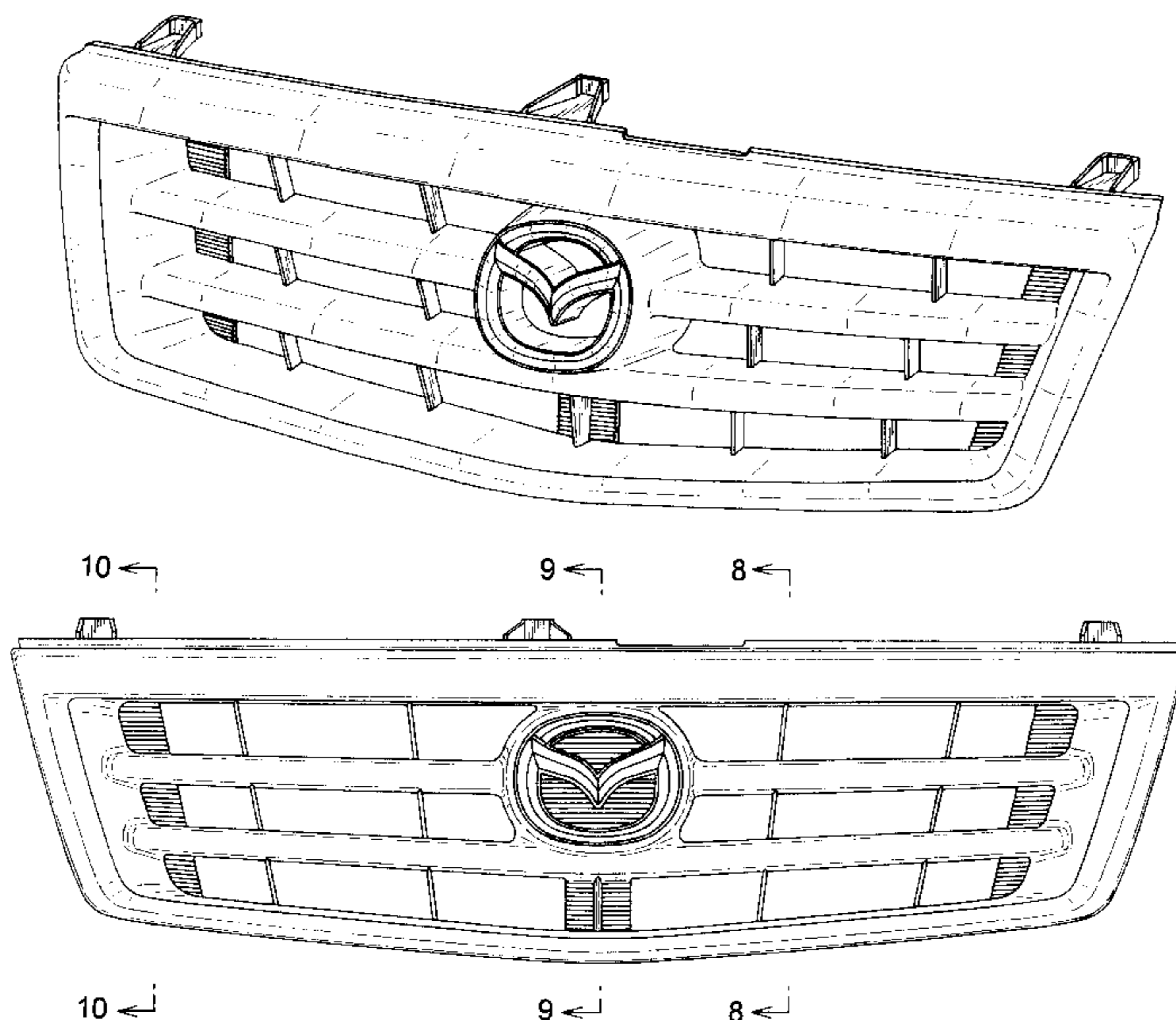

FIG. 1

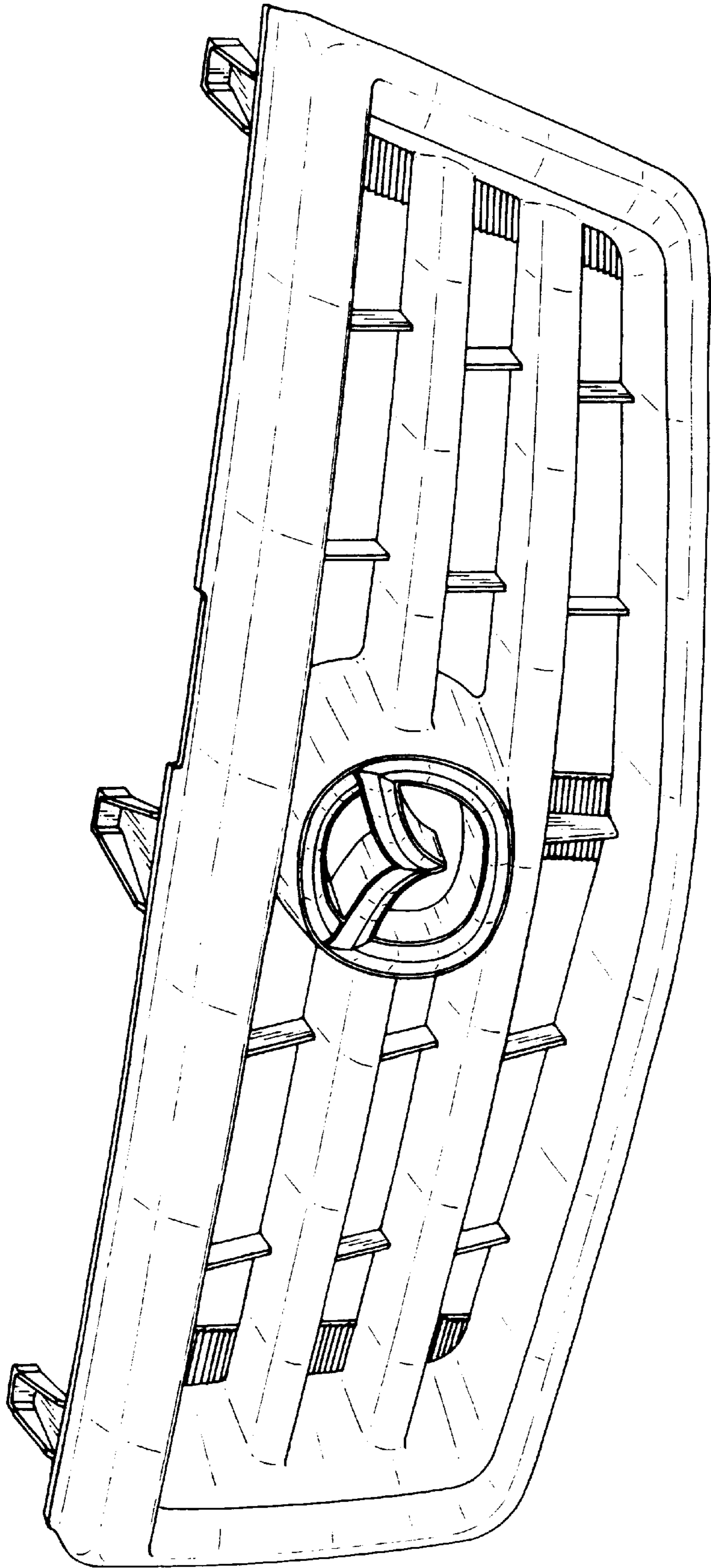

FIG. 2

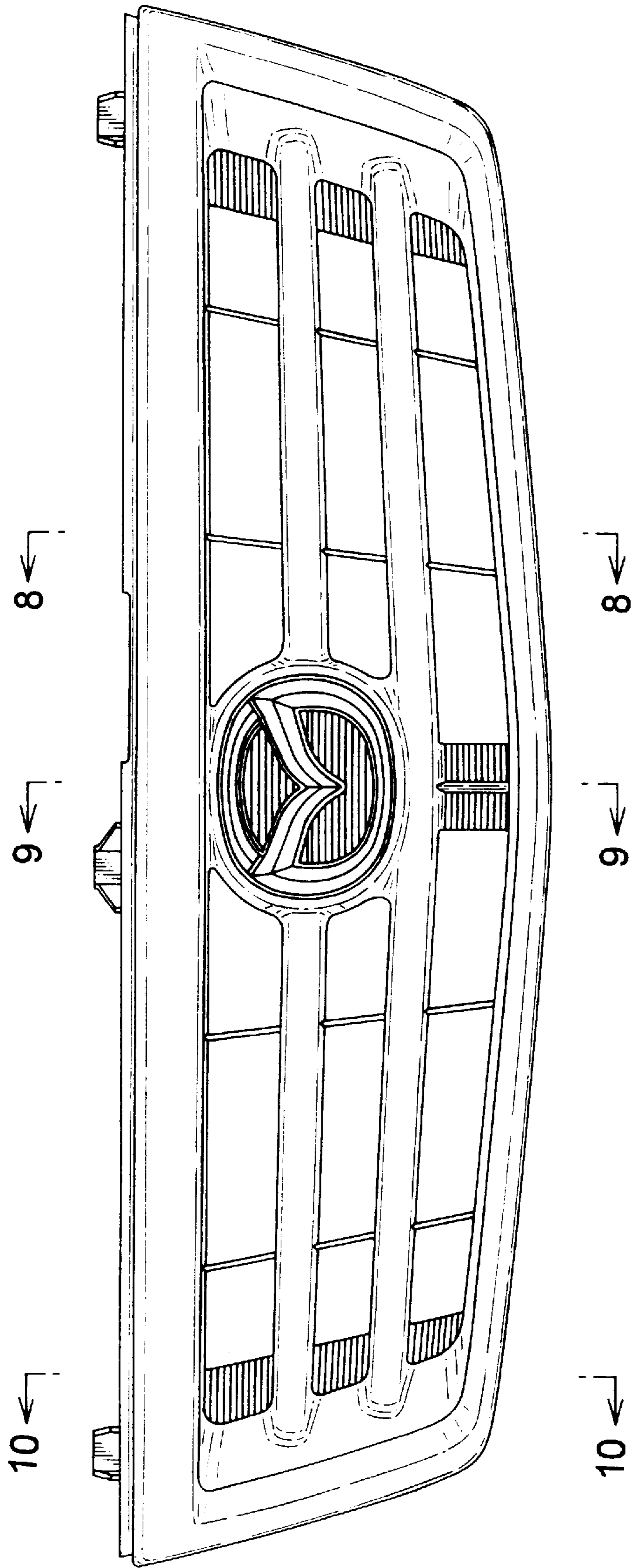

FIG. 3

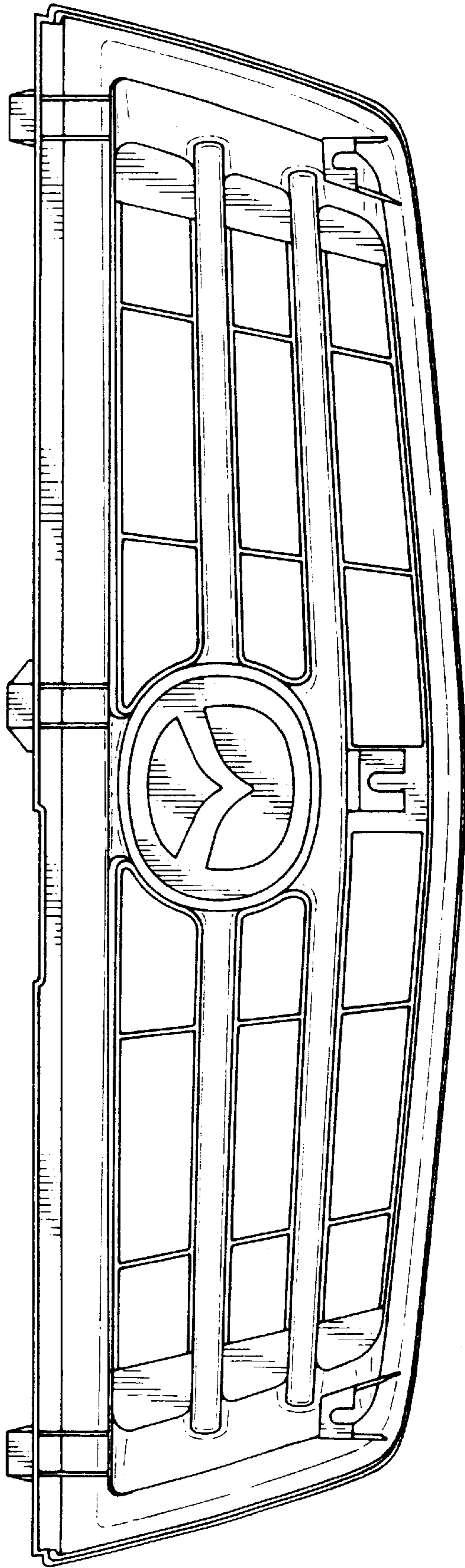

FIG. 4

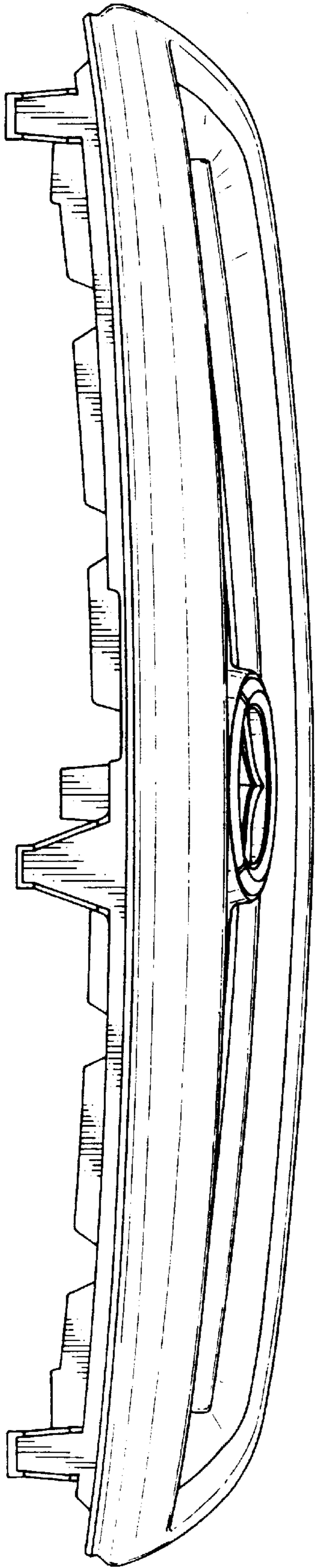

FIG. 5

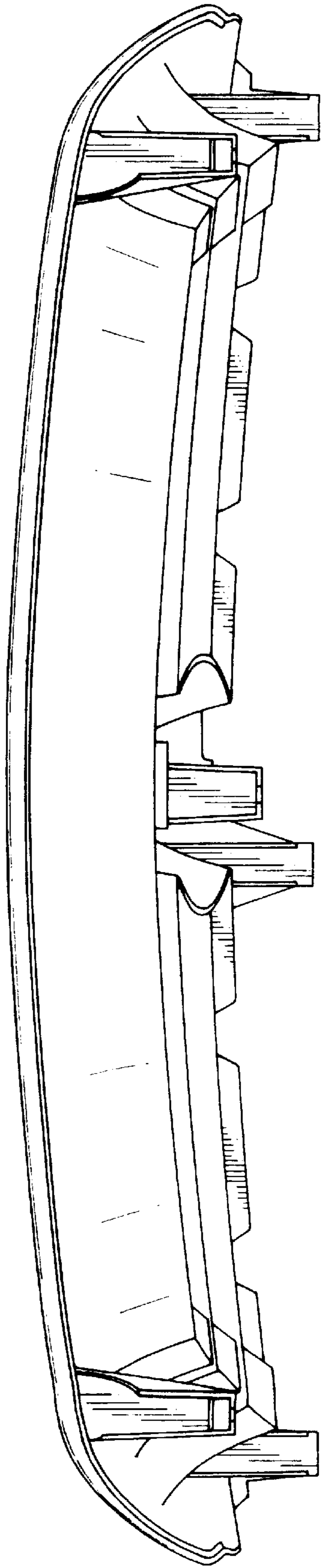

FIG. 7

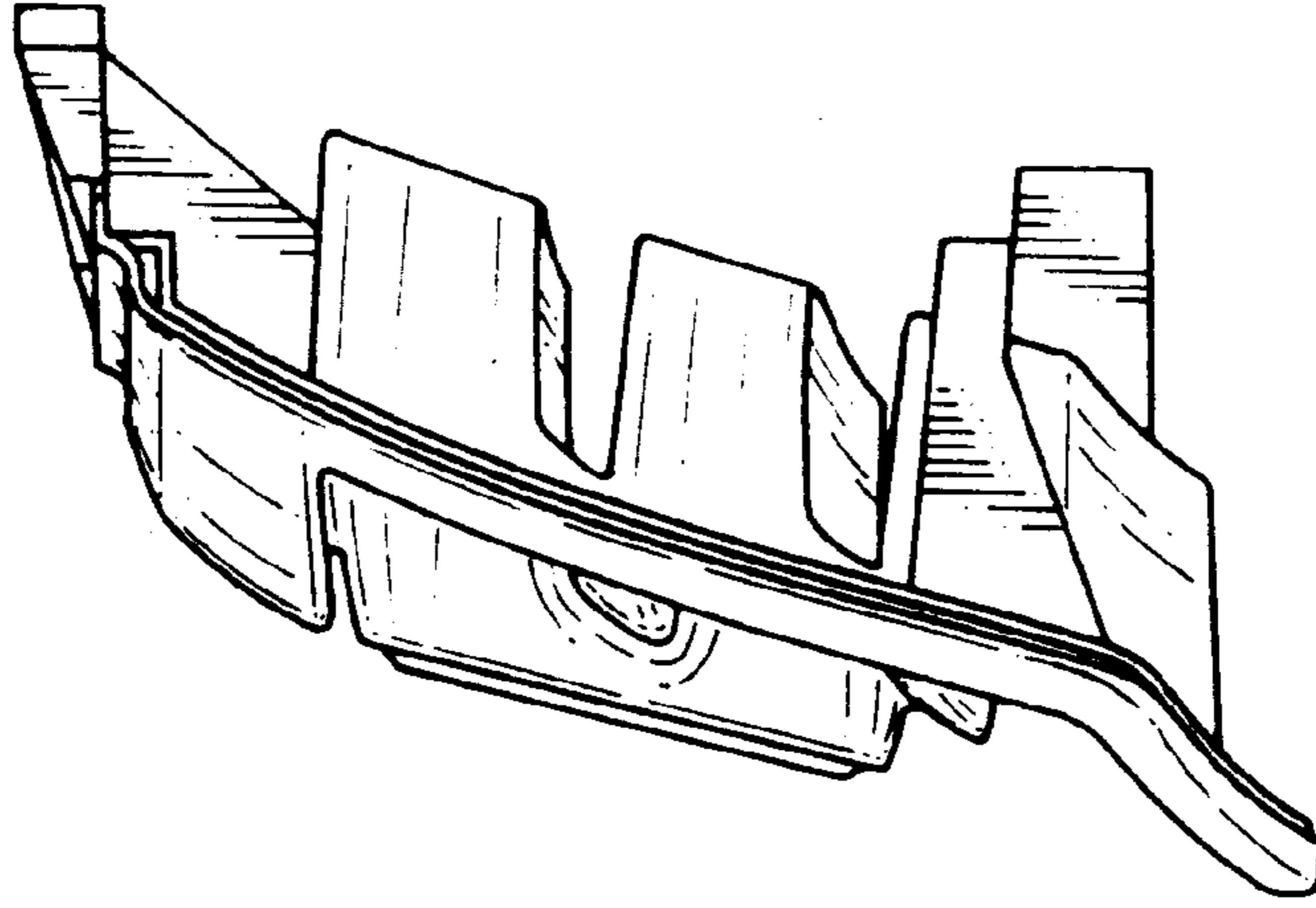

FIG. 6

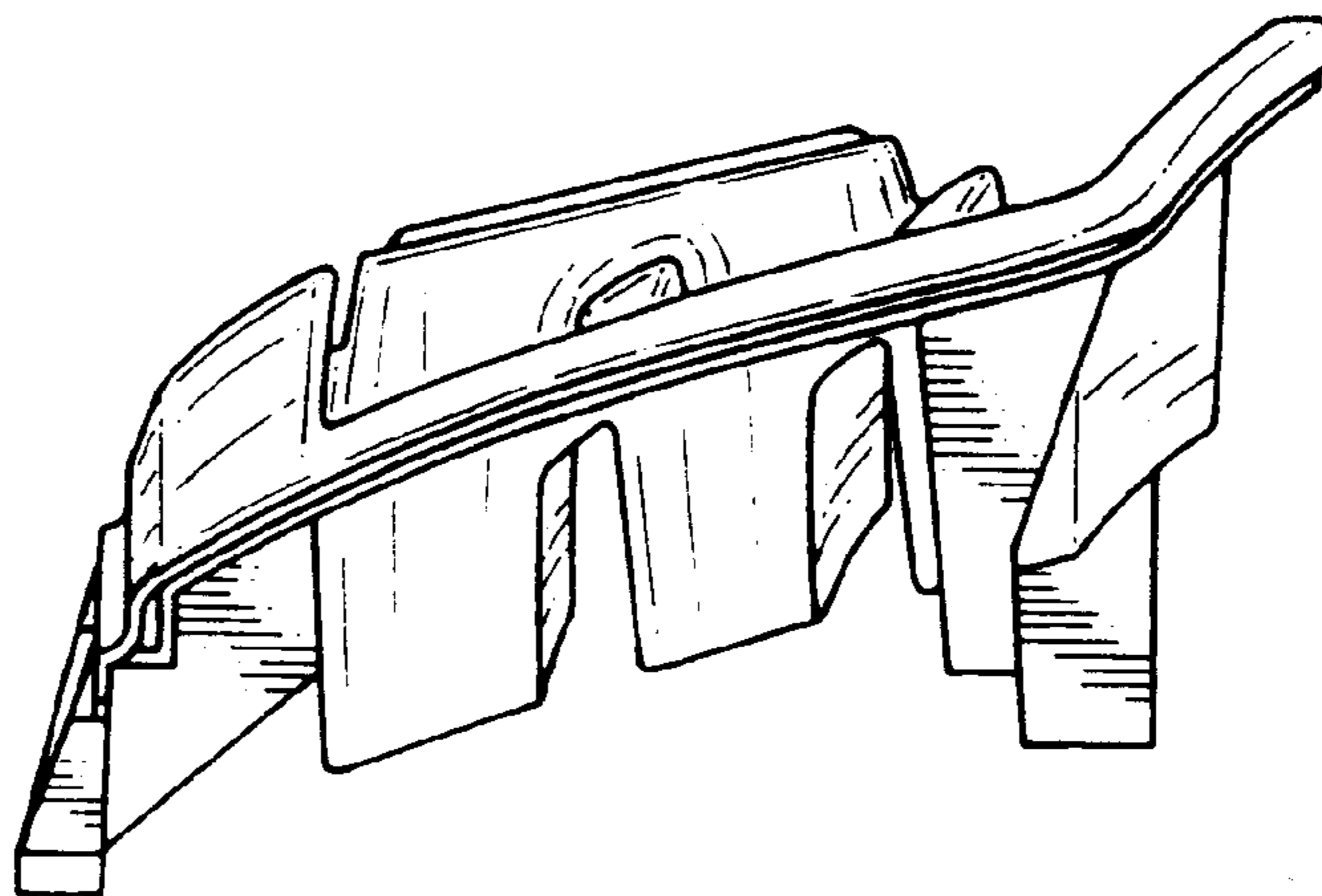

FIG. 9

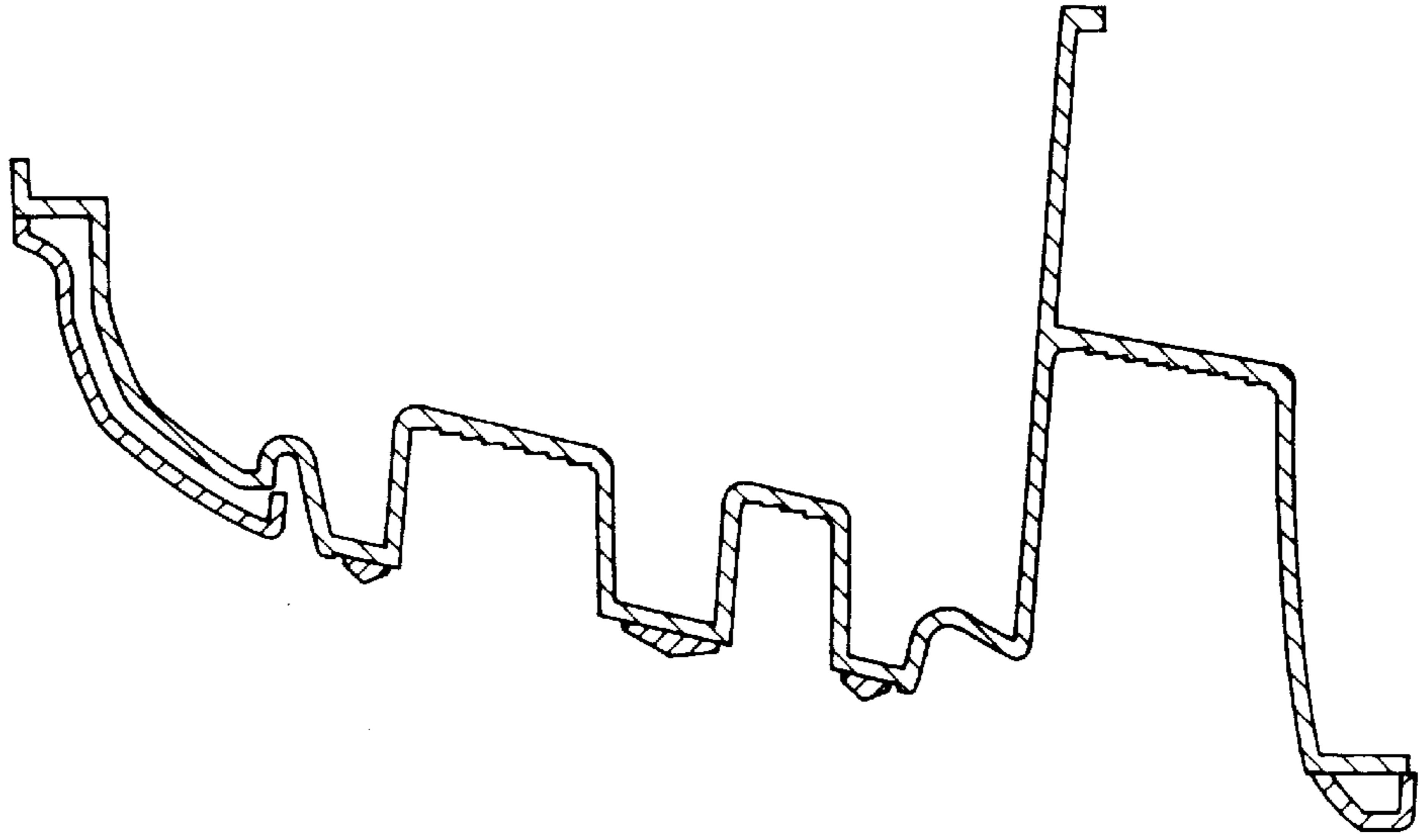

FIG. 8

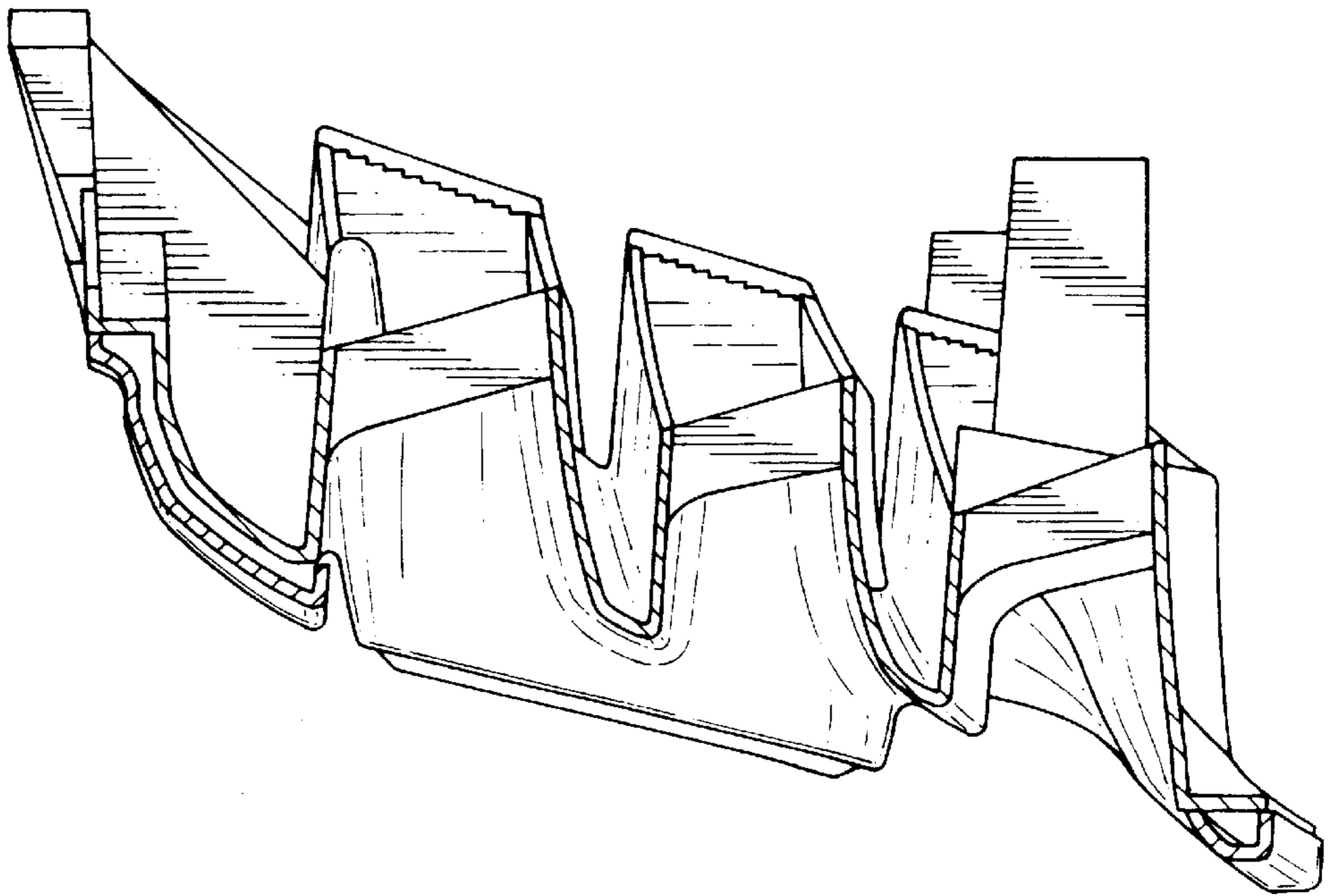

FIG. 10

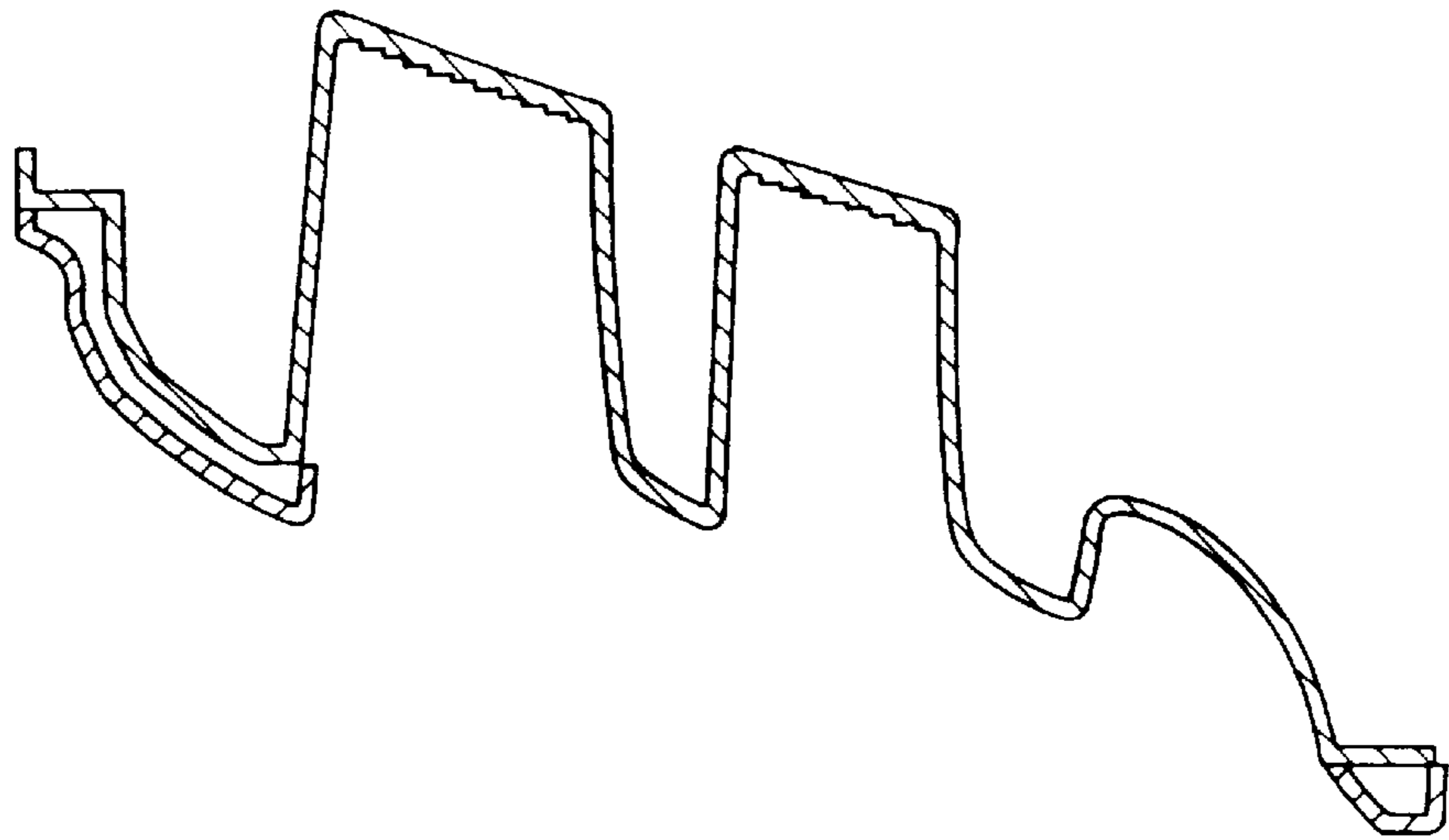

FIG. 11

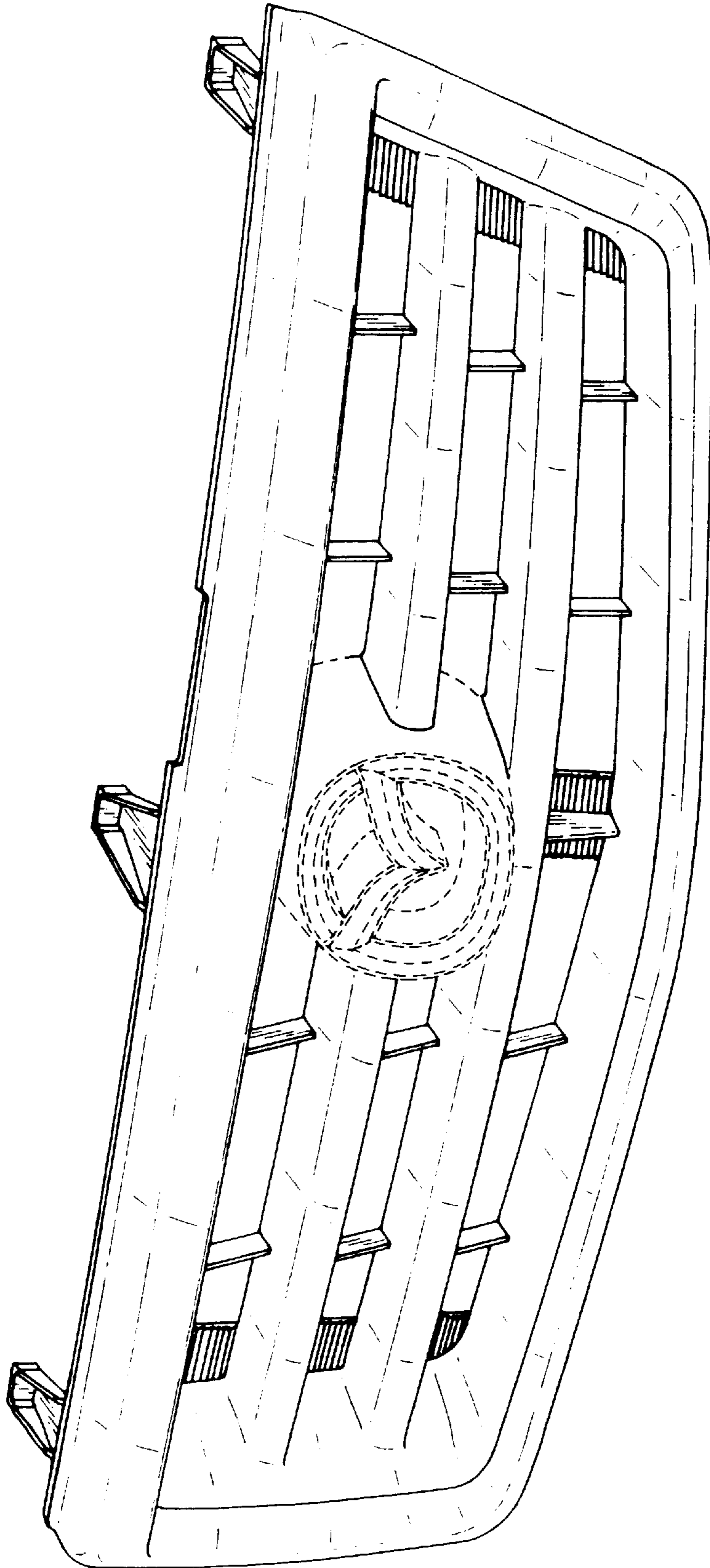

FIG. 12

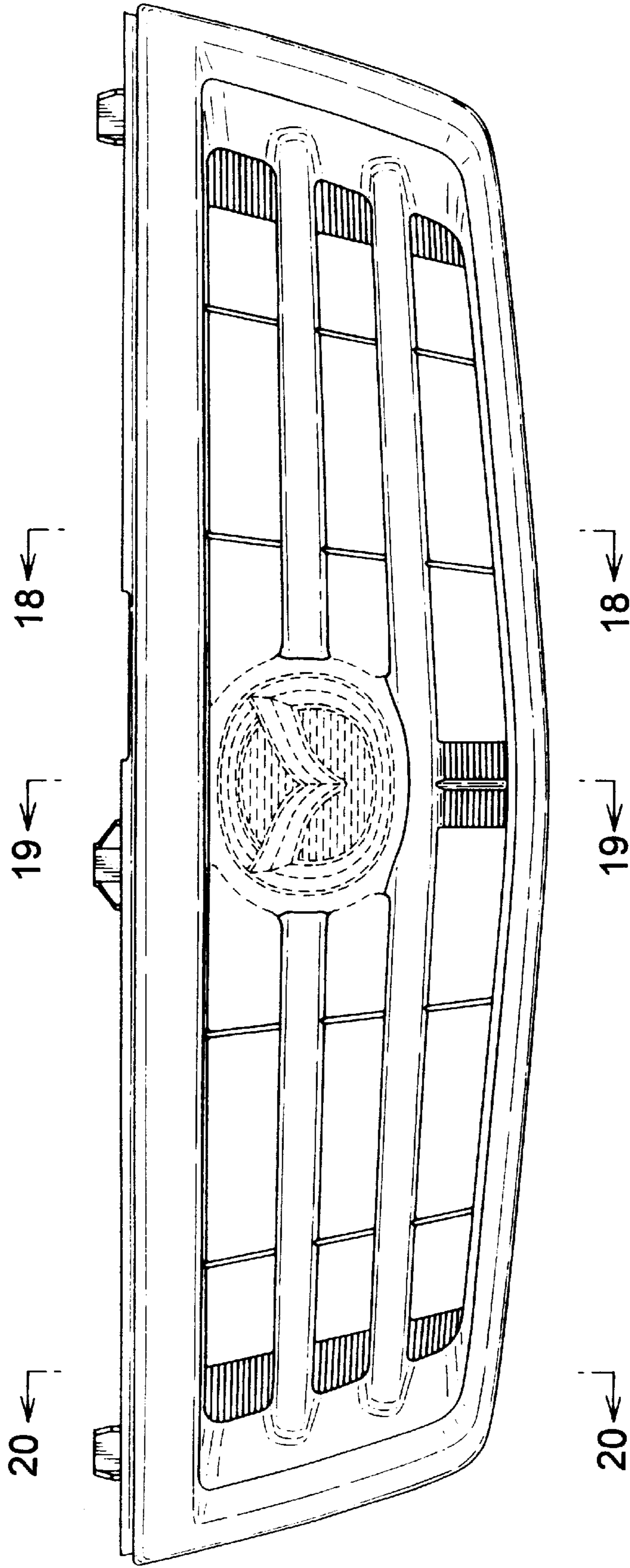

FIG. 13

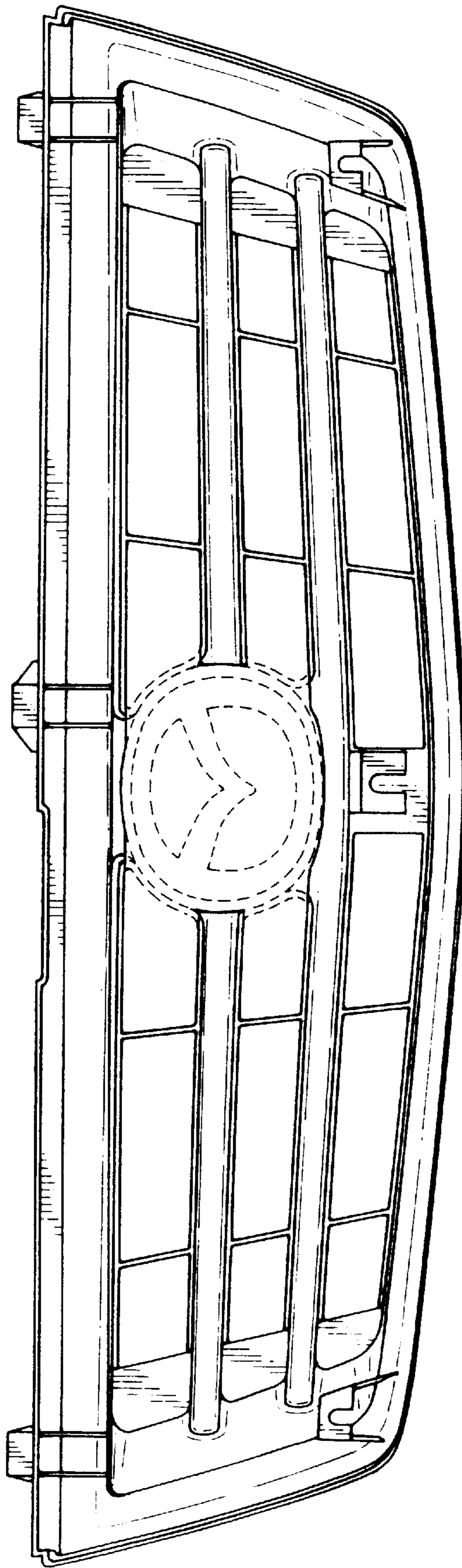

FIG. 14

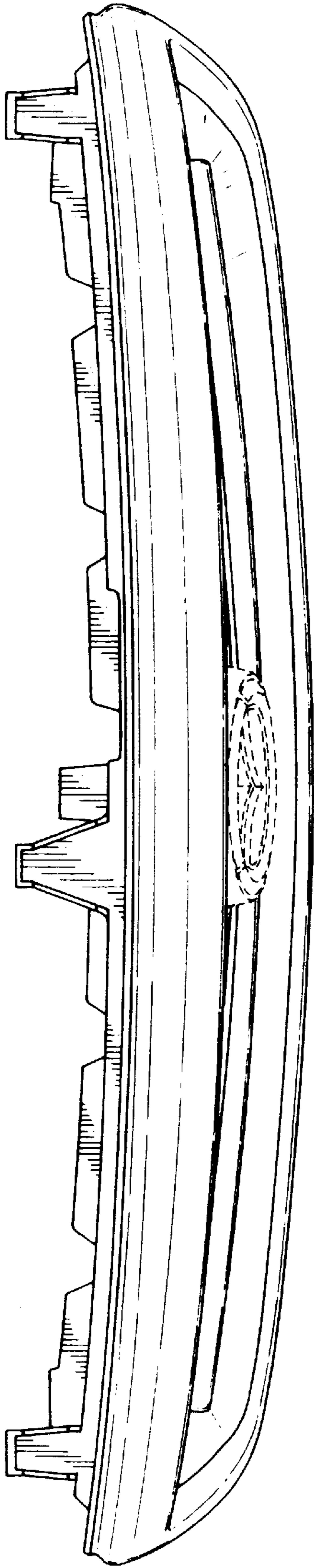

FIG. 15

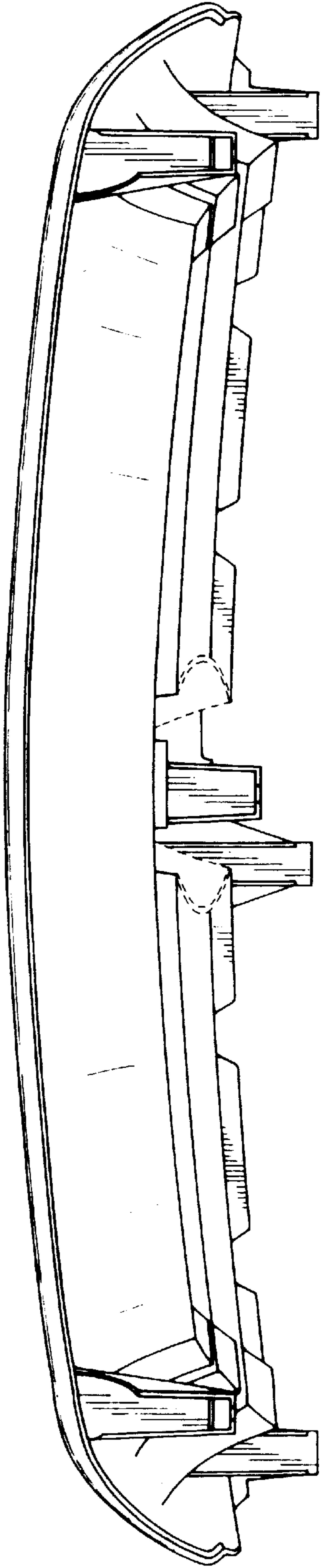

FIG. 17

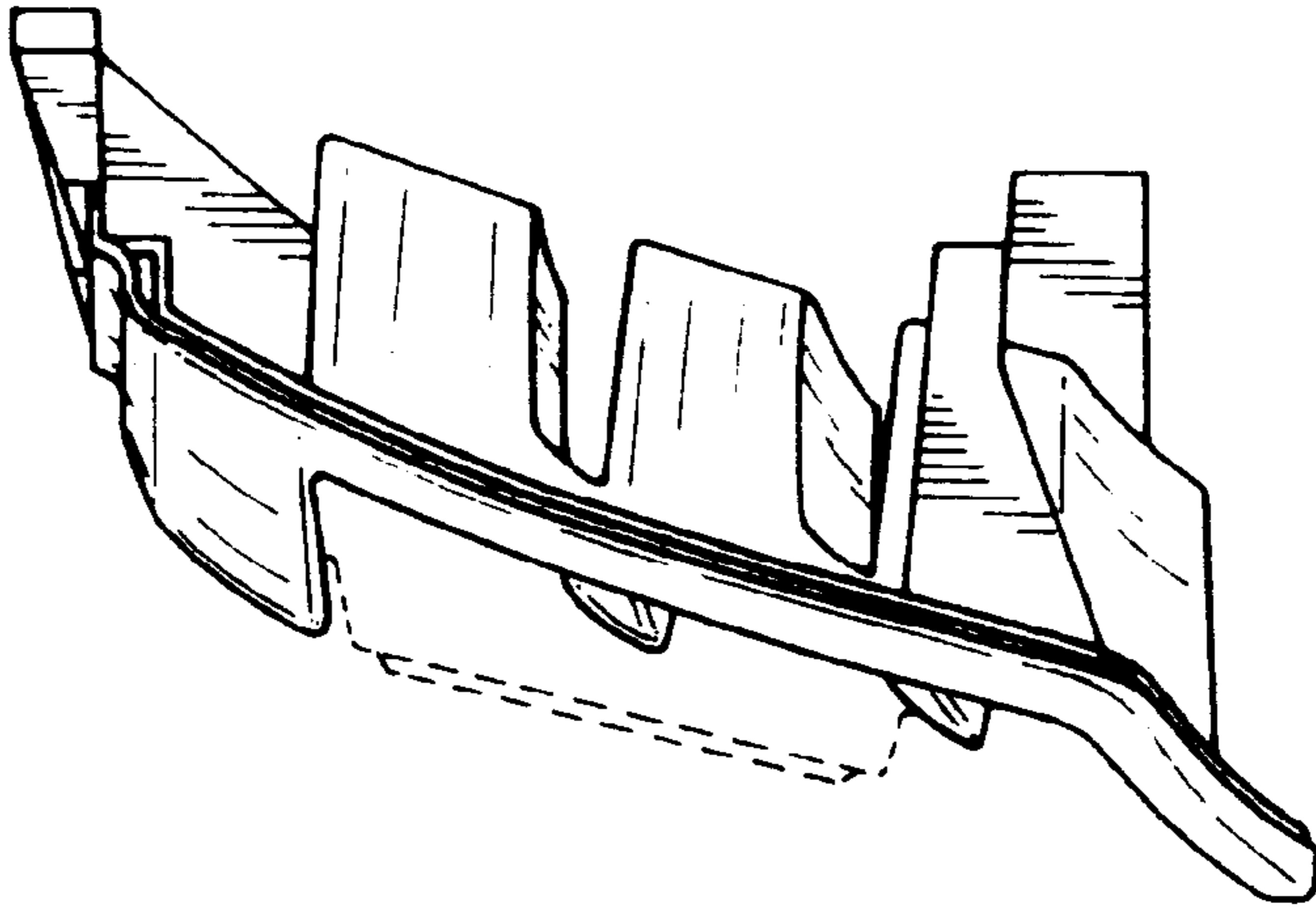

FIG. 16

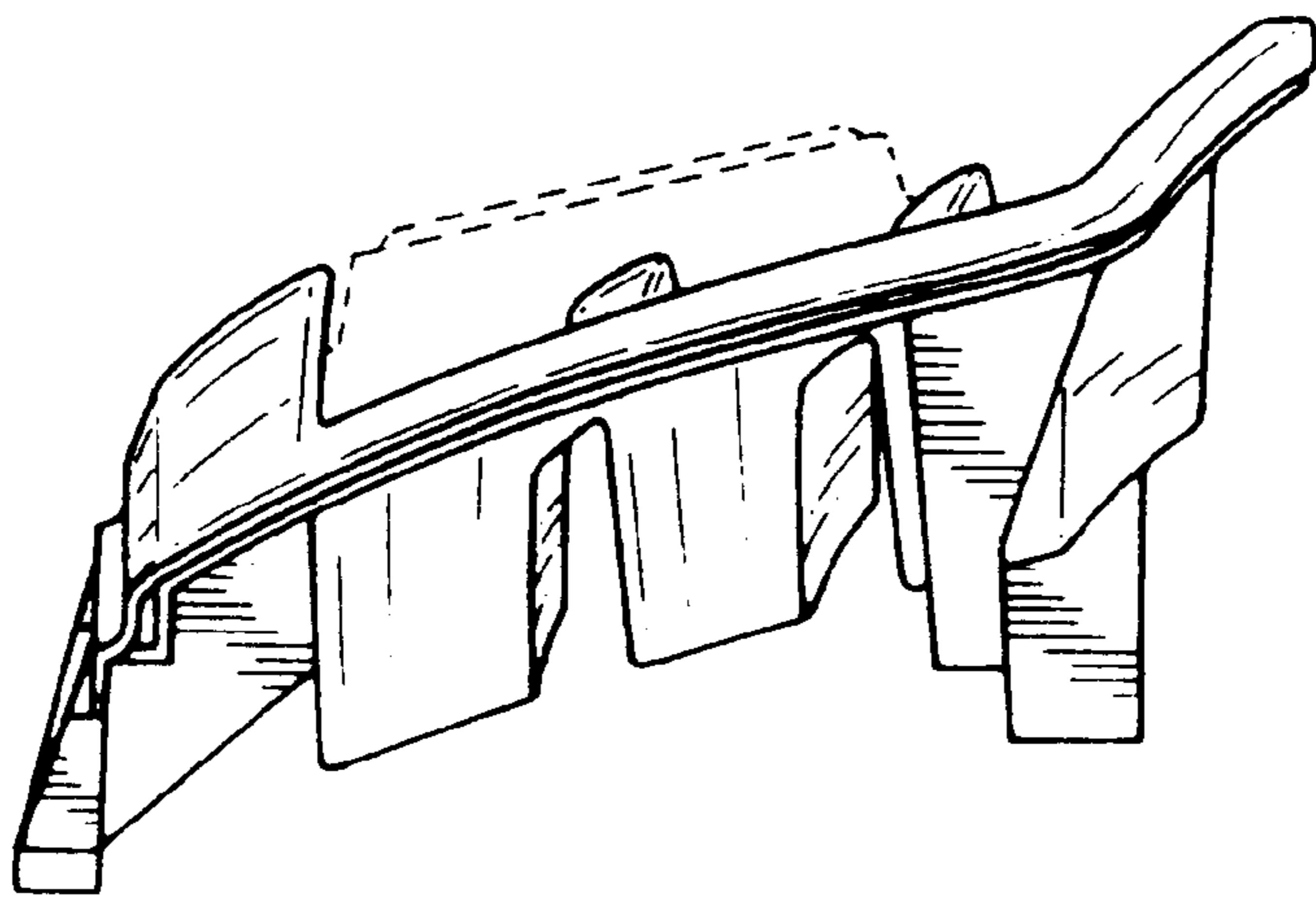

FIG. 19

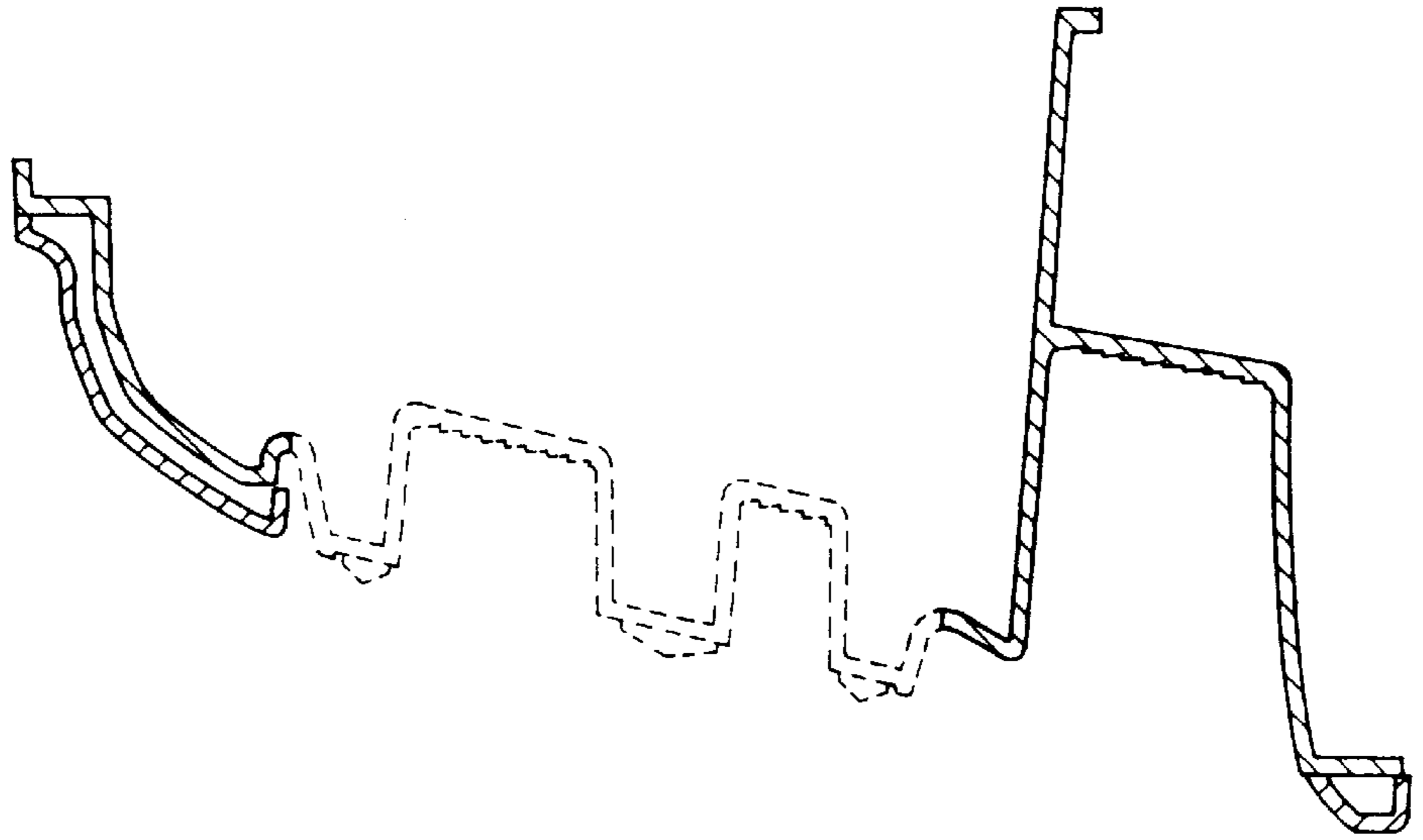

FIG. 18

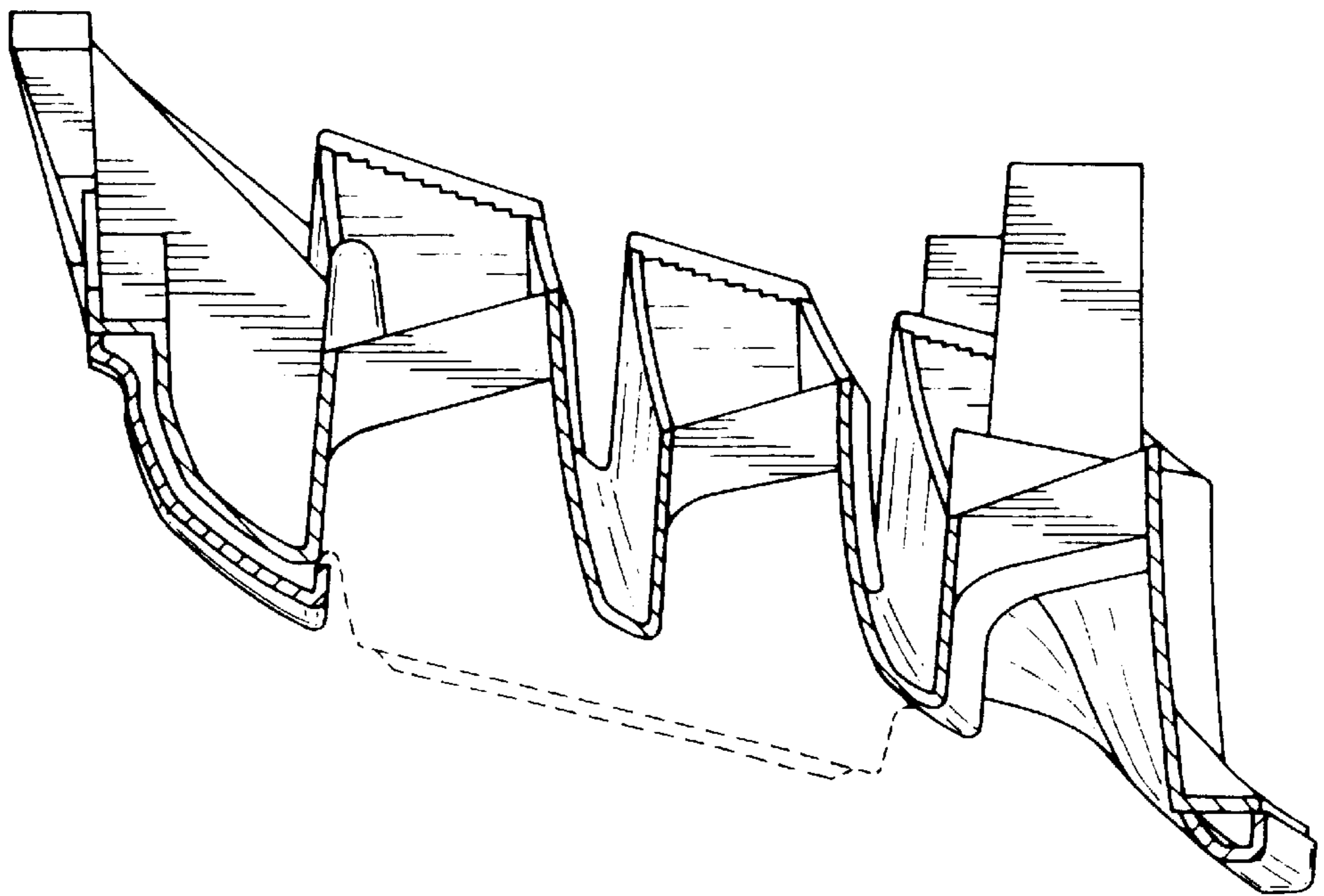

FIG. 20

