



US00D430256S

United States Patent [19] Addleman

[11] Patent Number: **Des. 430,256**

[45] Date of Patent: **** Aug. 29, 2000**

[54] **SCHOOL BUS SPRING RIDE**

D. 366,513 1/1996 Crowe et al. D21/833

[75] Inventor: **Keith A. Addleman**, Hillsdale, Mich.

OTHER PUBLICATIONS

Mexico Forge; pp. 24 and 25, Jun. 1984.

[73] Assignee: **The Shane Group, Inc.**, Hillsdale, Mich.

Primary Examiner—Mitchell Siegel
Attorney, Agent, or Firm—Young & Basile, P.C.

[**] Term: **14 Years**

[57] CLAIM

[21] Appl. No.: **29/112,209**

The ornamental view of a school bus spring ride, substantially as shown.

[22] Filed: **Oct. 14, 1999**

DESCRIPTION

[51] **LOC (7) Cl.** **21-03**

[52] **U.S. Cl.** **D21/833**

[58] **Field of Search** D21/828, 831,
D21/833; 273/85 R, 856, 150, 431, 434,
148 G; D12/82, 84

FIG. 1 is a side elevational view of a school bus spring ride constructed in accord with my new design illustrating the left side thereof, the right side being a mirror image of the side illustrated, the spring support illustrated in phantom lines does not constitute a part of the invention as shown in the drawings;

[56] References Cited

U.S. PATENT DOCUMENTS

D. 187,036	1/1960	Corts	D21/832
D. 189,456	12/1960	Hansen	D21/832
D. 192,254	2/1962	Hansen	D21/832
D. 192,255	2/1962	Hansen	D21/832
D. 225,872	1/1973	Burke	D21/833

FIG. 2 is a front elevational view of the new design as taken from the left of FIG. 1;

FIG. 3 is a rear elevational view of the new design as taken from the right of FIG. 1; and,

FIG. 4 is a top plan view of my design.

1 Claim, 2 Drawing Sheets

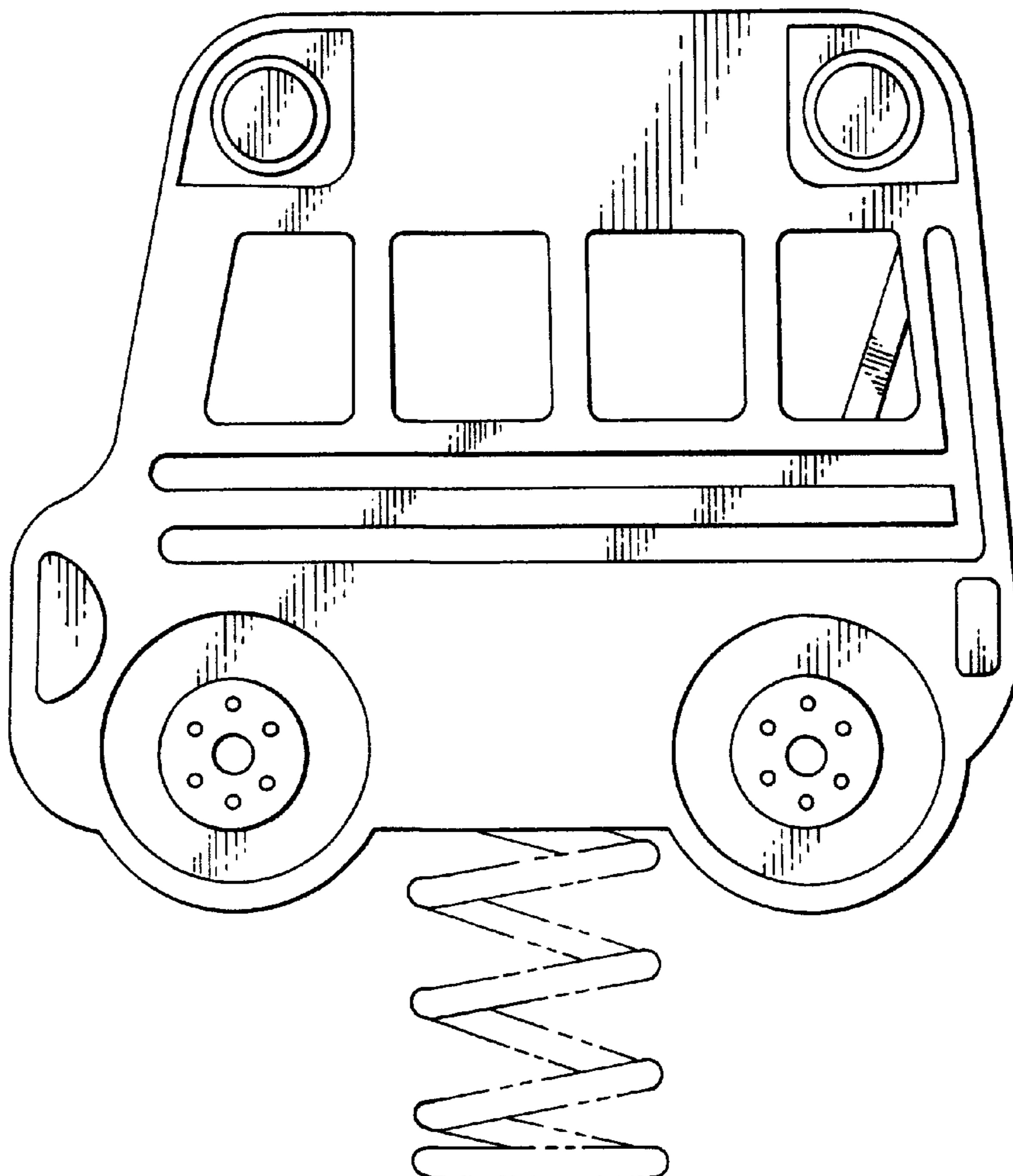

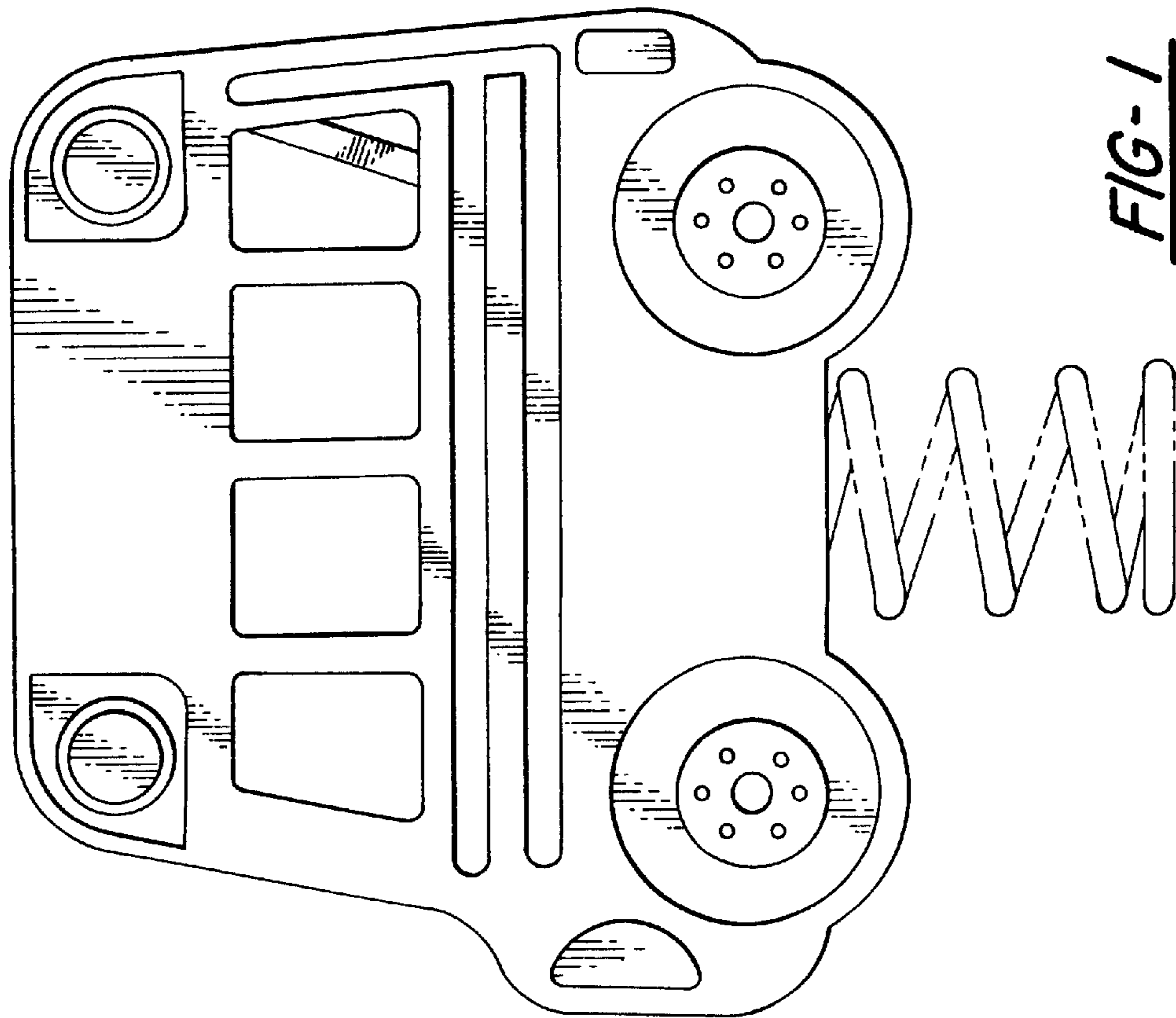
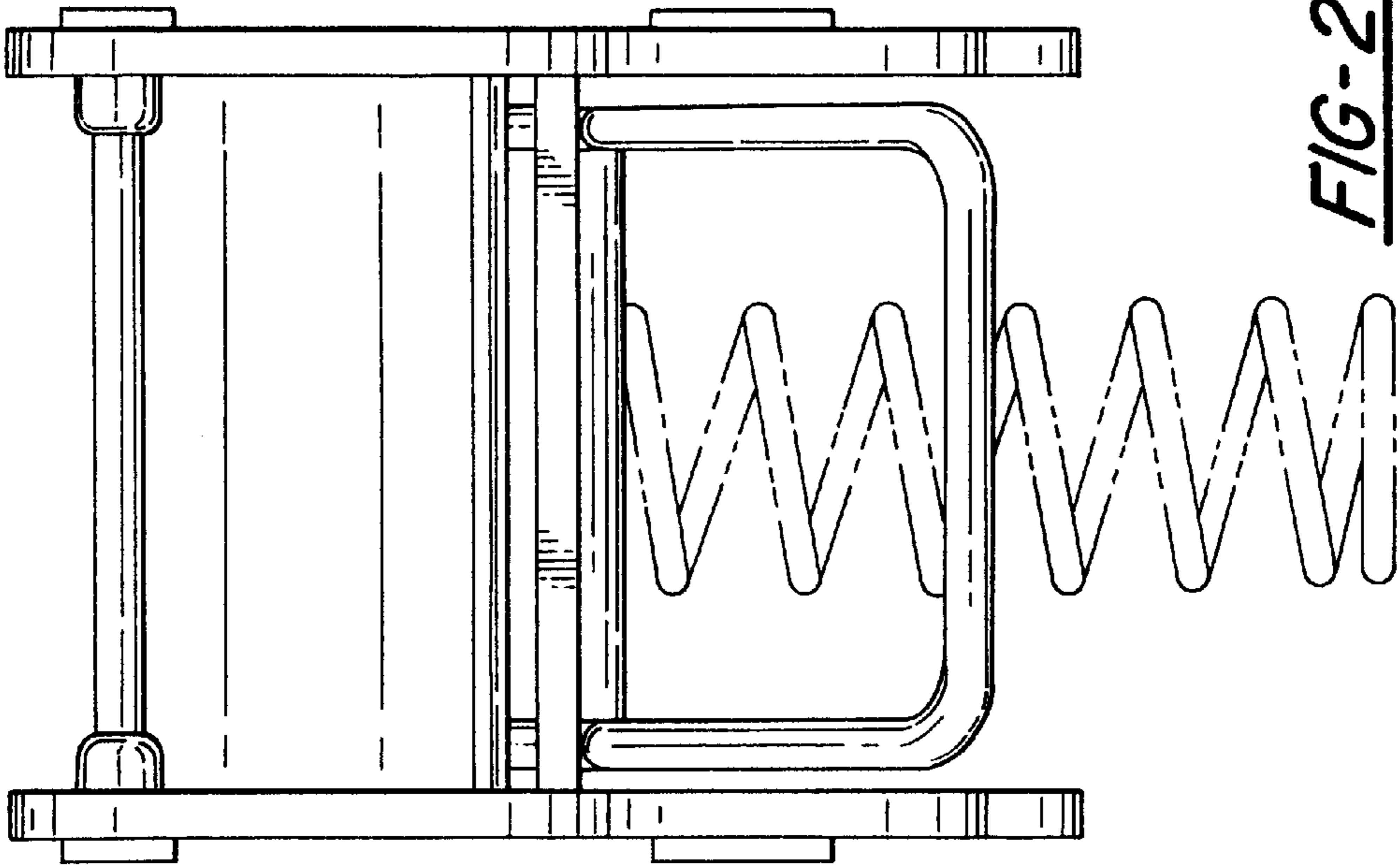

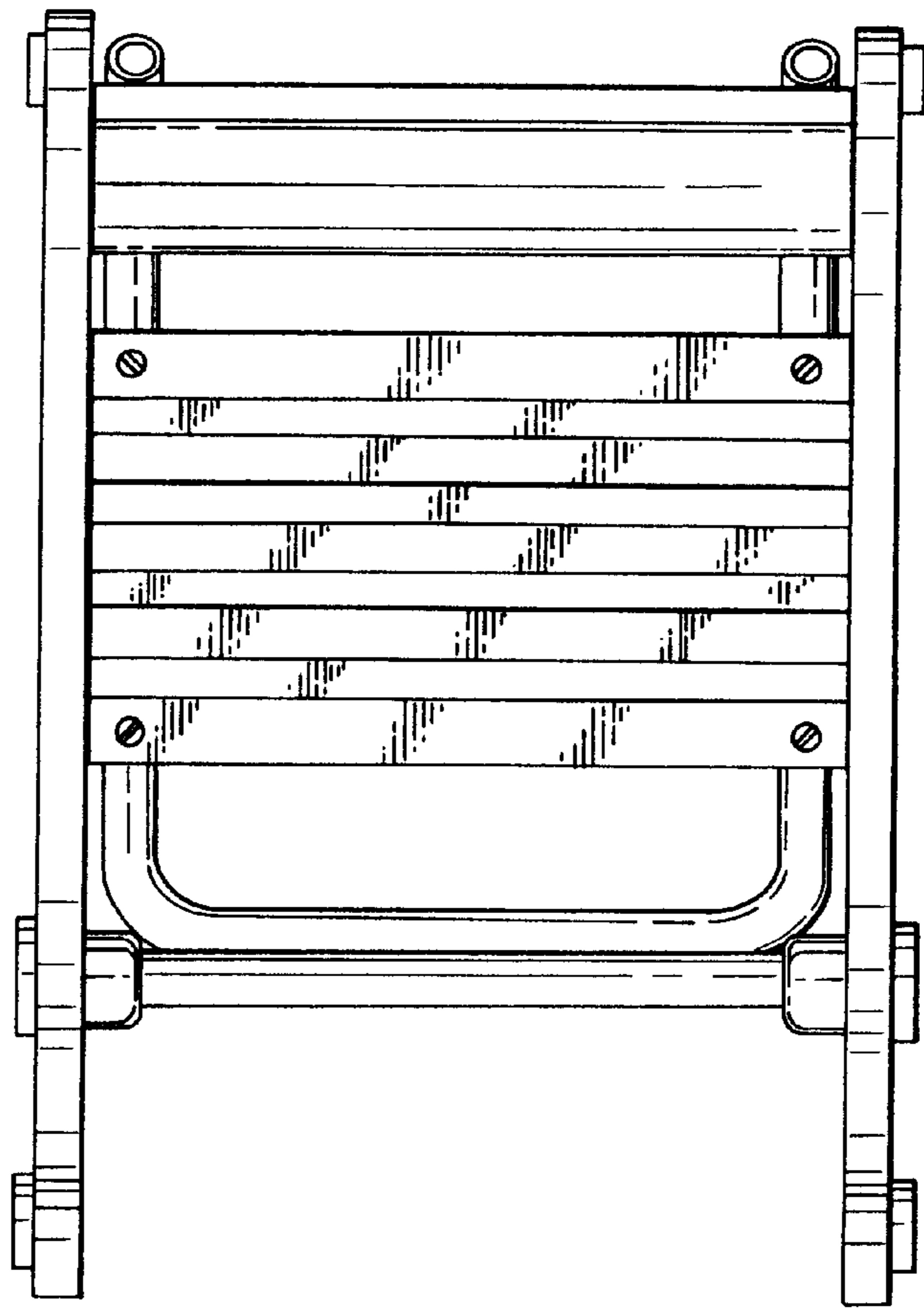

FIG-4

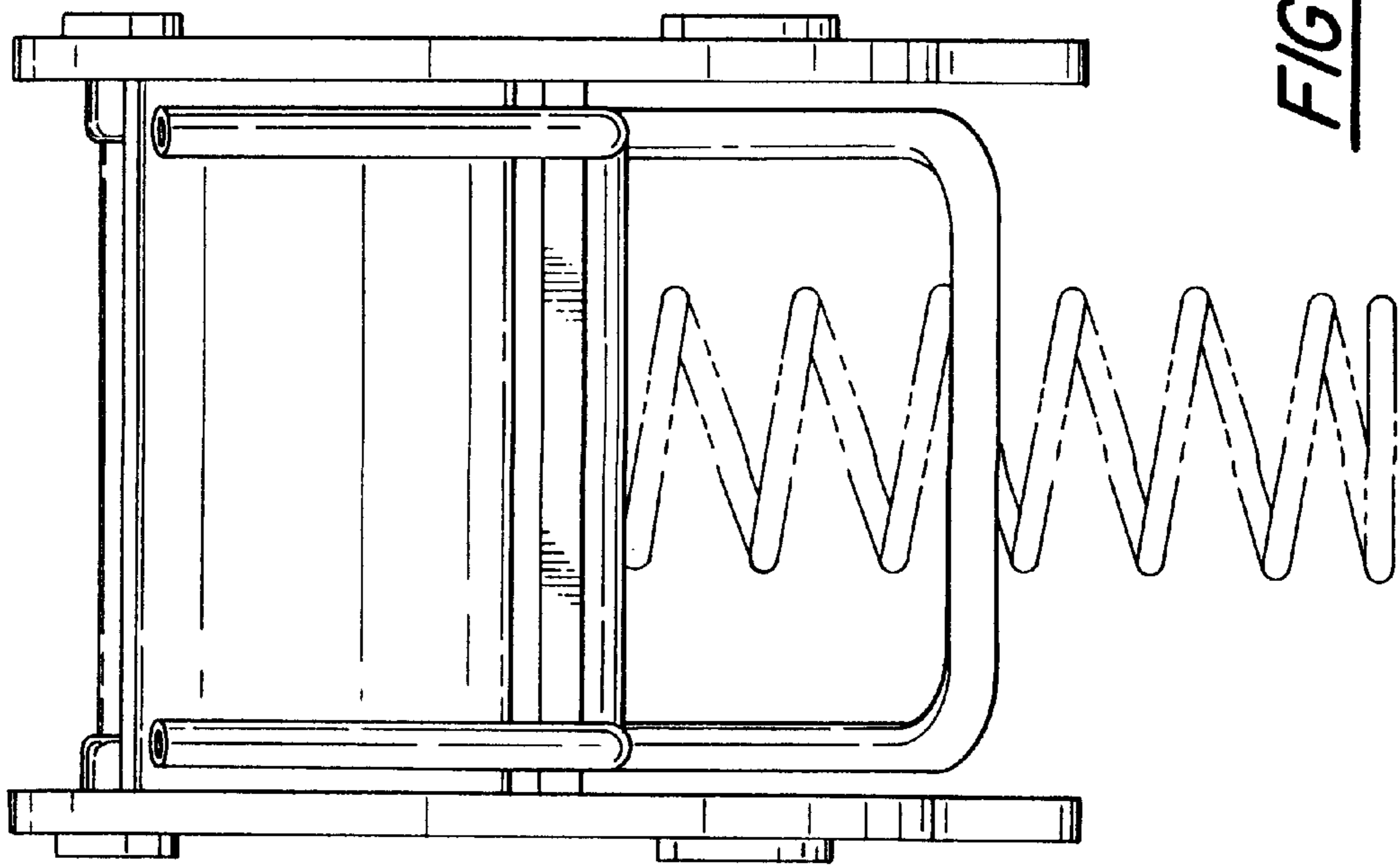

FIG-3