



US00D430149S

**United States Patent** [19]  
**Afshar-Ghochani**

[11] **Patent Number: Des. 430,149**

[45] **Date of Patent: \*\* Aug. 29, 2000**

[54] **HANDSET CABLE PLATE FOR A PAY TELEPHONE**

[75] Inventor: **Shahram Afshar-Ghochani**, Tampa, Fla.

[73] Assignee: **Protel, Inc.**, Lakeland, Fla.

[\*\*] Term: **14 Years**

[21] Appl. No.: **29/111,123**

[22] Filed: **Sep. 21, 1999**

[51] **LOC (7) Cl.** ..... **14-03**

[52] **U.S. Cl.** ..... **D14/240; D14/146**

[58] **Field of Search** ..... D14/130, 230, D14/140, 142, 149-151, 146, 240, 238; 379/433-436, 419, 420, 428, 440, 430, 453, 143-155, 368, 441, 442, 438; D8/353; 174/151, 153 G, 65 R, 65 G, 66, 67; D13/177, 156, 154

[56] **References Cited**

**U.S. PATENT DOCUMENTS**

D. 56,022	8/1920	Newton	.....	D8/353
D. 126,098	3/1941	McIntosh	.....	D8/353
D. 209,142	11/1967	Carlson	.....	D8/353
D. 290,954	7/1987	Read	.	
D. 305,890	2/1990	Read	.	
D. 309,093	7/1990	Reinholt	.....	D8/353
D. 342,235	12/1993	Shotey	.....	D13/156
D. 351,376	10/1994	Hughes	.....	D13/177

D. 369,953	5/1996	Carr	.....	D8/353
D. 370,890	6/1996	Tiberio, Jr.	.....	D13/156 X
D. 374,809	10/1996	Scherer et al.	.....	D8/353
D. 396,041	7/1998	Read	.....	D14/238
D. 399,829	10/1998	Reed	.....	D13/156
D. 410,003	5/1999	Lamora	.....	D14/146
D. 411,734	6/1999	Hsiang	.....	D8/353
D. 424,049	5/2000	Ho et al.	.....	D14/130
4,518,830	5/1985	Drexler et al.	.....	379/438
4,688,747	8/1987	Helmsdorfer et al.	.....	174/67 X
5,086,465	2/1992	Bass	.....	379/438
5,471,529	11/1995	Hsu	.....	379/438

*Primary Examiner*—Jeffrey Asch  
*Attorney, Agent, or Firm*—Allen, Dyer, Doppelt, Milbrath & Gilchrist, P.A.

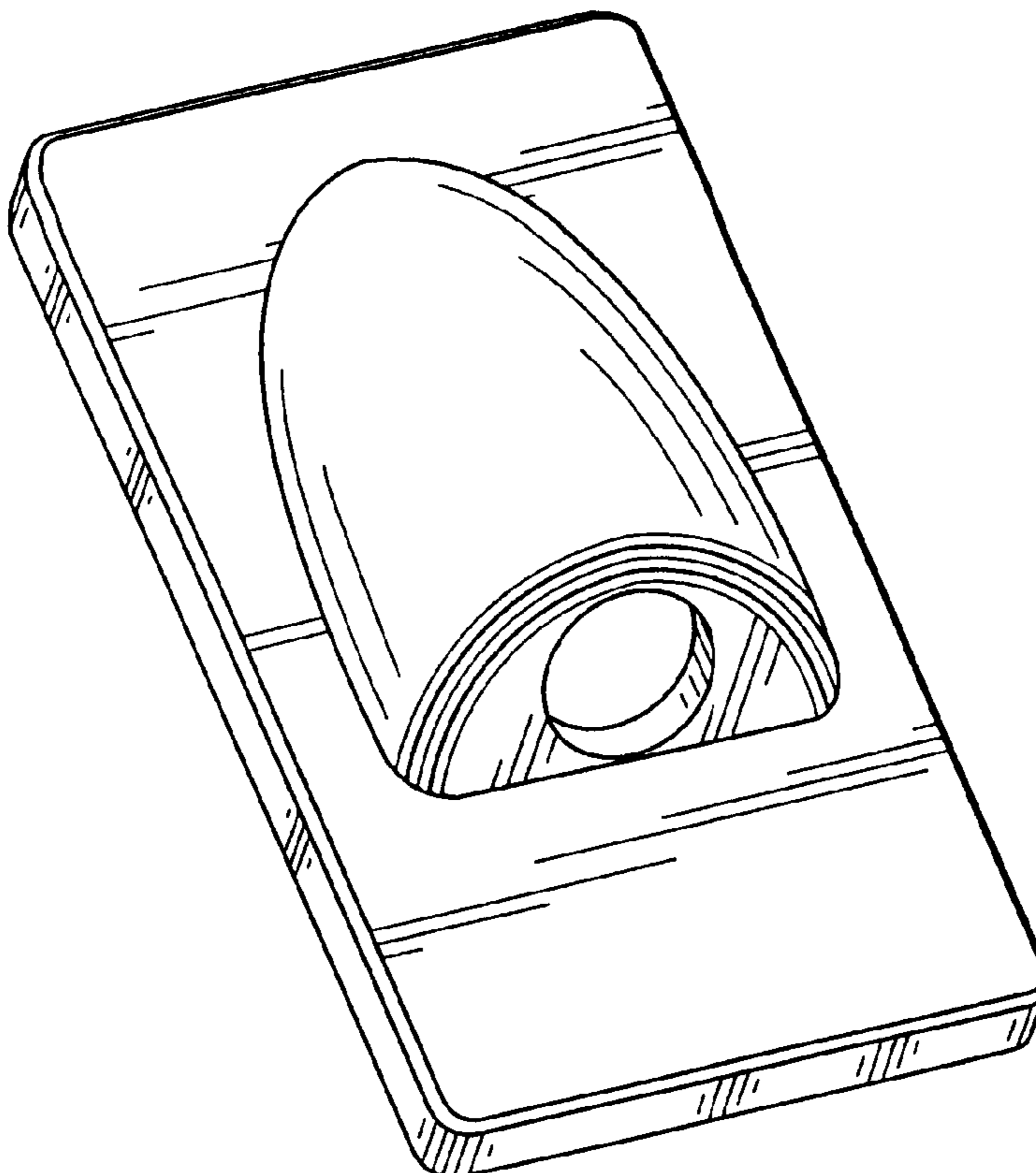
[57] **CLAIM**

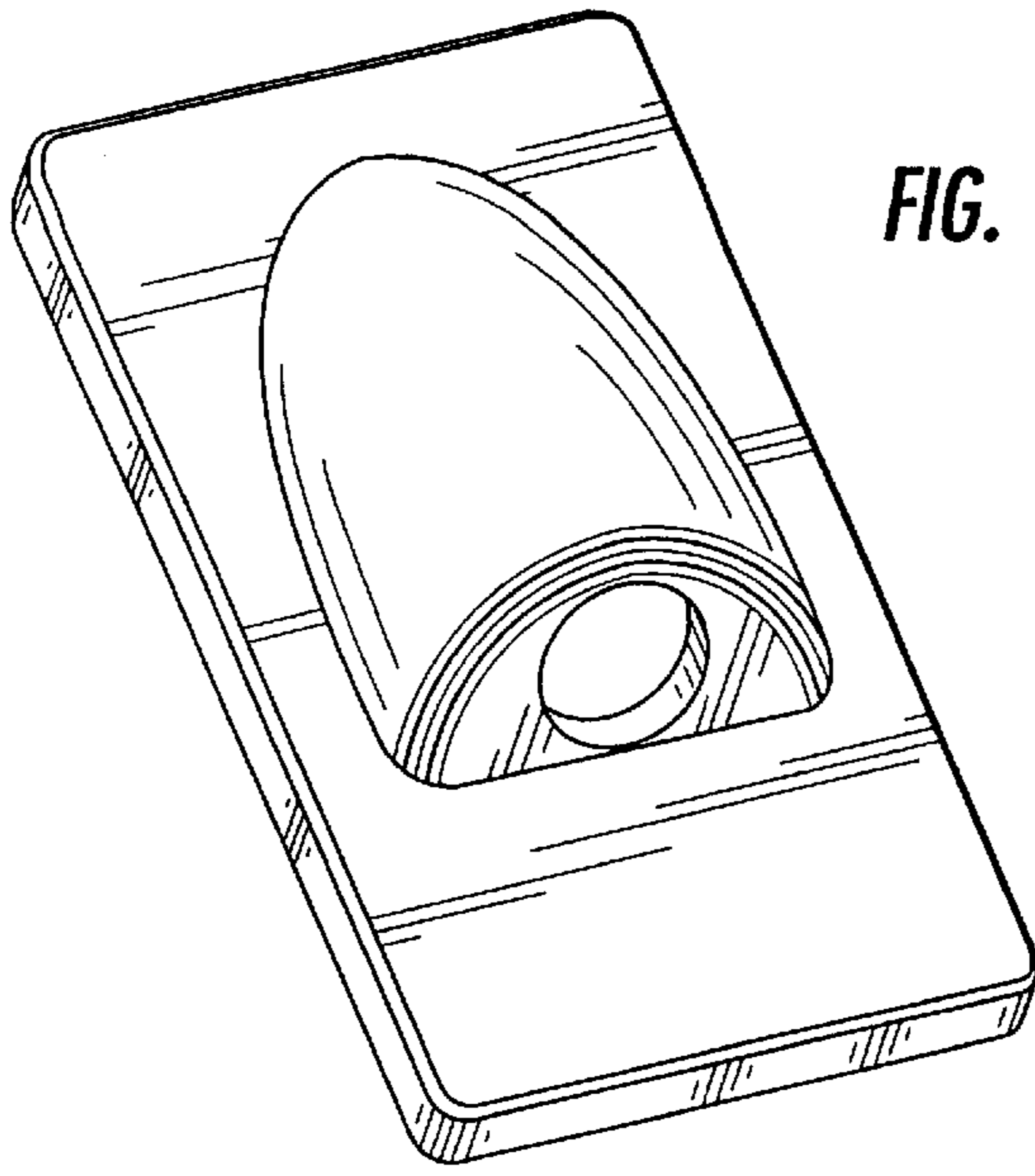
The ornamental design for a handset cable plate for a pay telephone, as shown and described.

**DESCRIPTION**

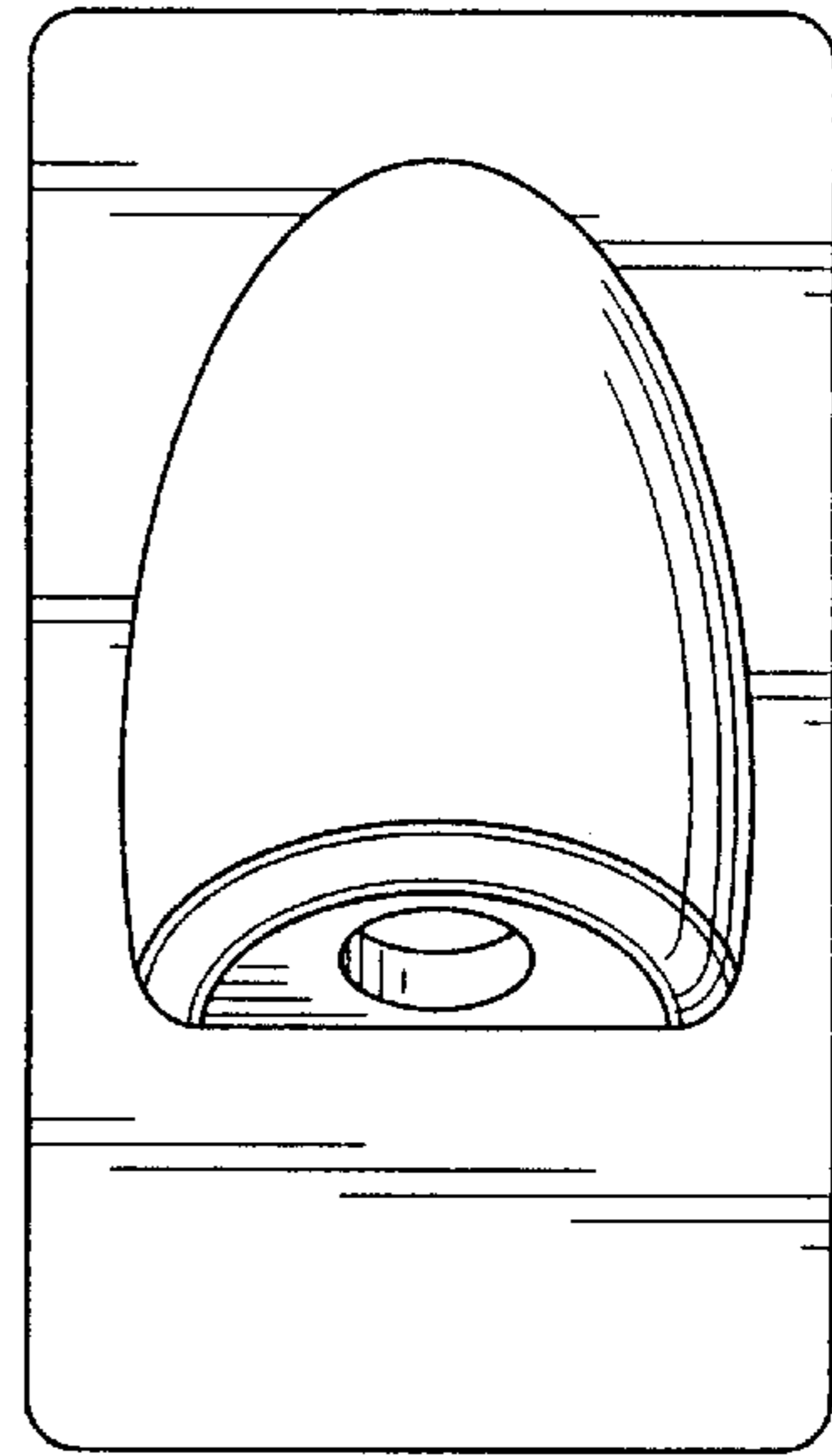
FIG. 1 is a front, bottom, and left side perspective view of a handset cable plate for a pay telephone showing my new design;  
FIG. 2 is a front elevation view thereof;  
FIG. 3 is a rear elevation view thereof;  
FIG. 4 is a bottom plan view thereof;  
FIG. 5 is a top plan view thereof;  
FIG. 6 is a reduced right side elevation view thereof; and,  
FIG. 7 is a reduced left side elevation view thereof.

**1 Claim, 1 Drawing Sheet**

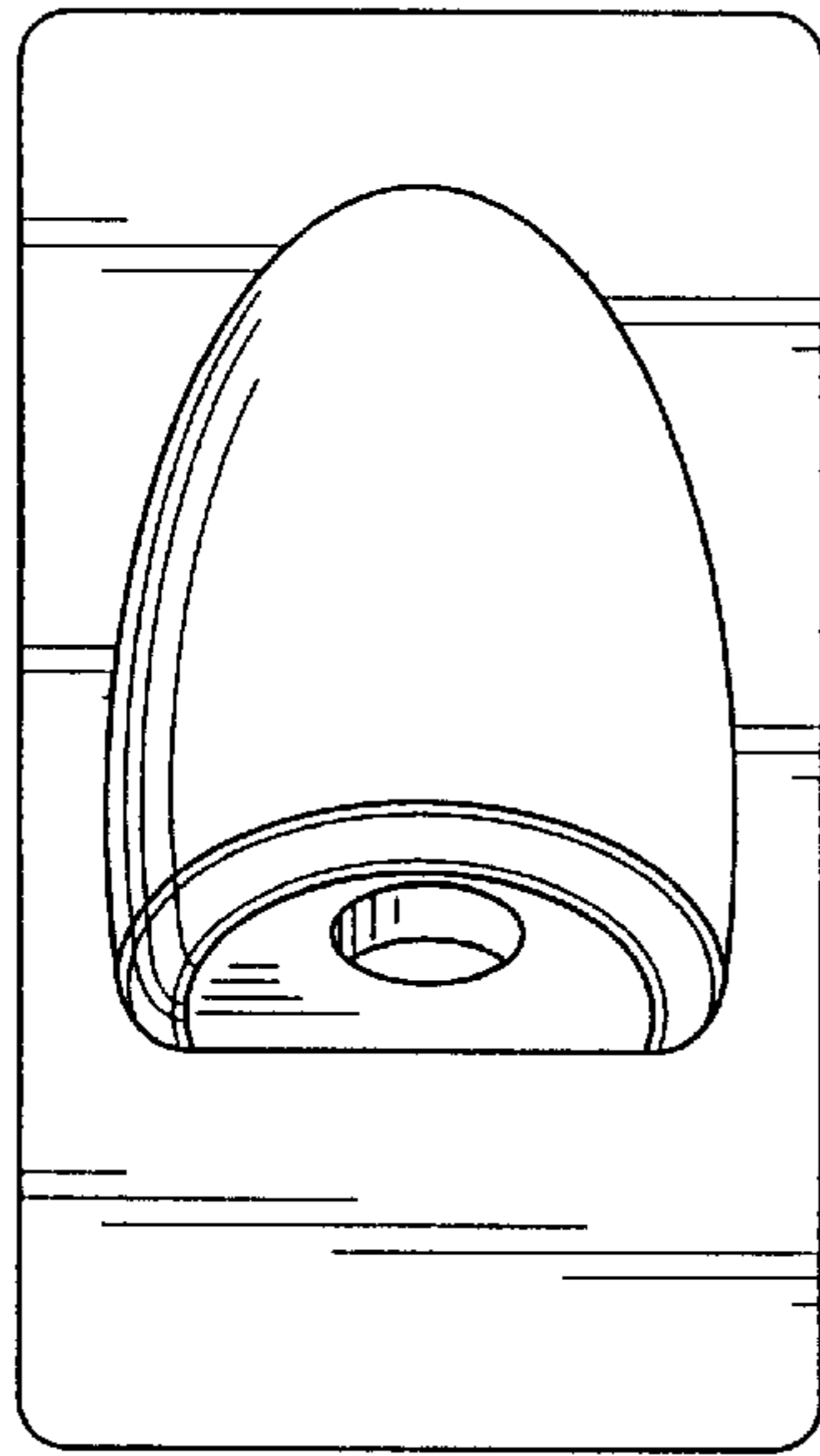




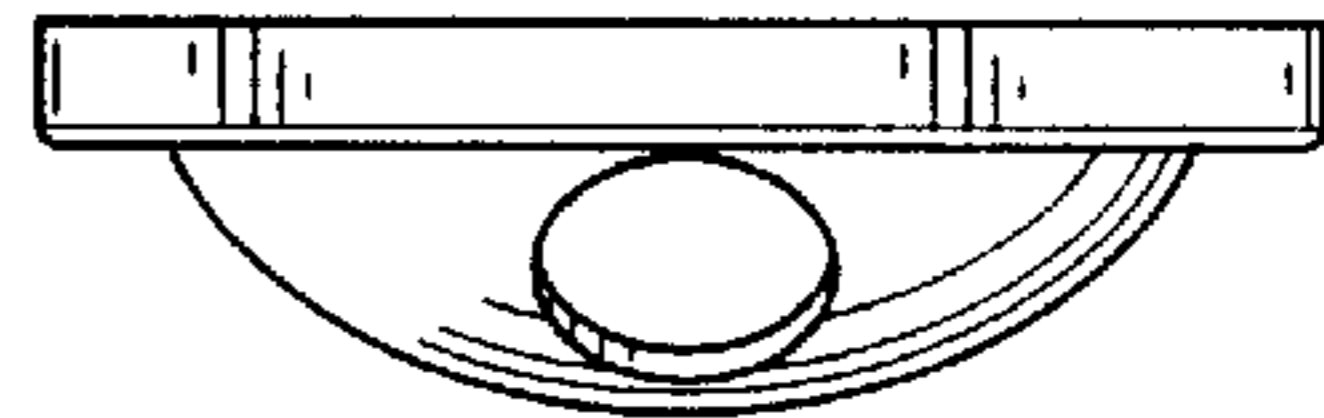
**FIG. 1.**



**FIG. 2.**



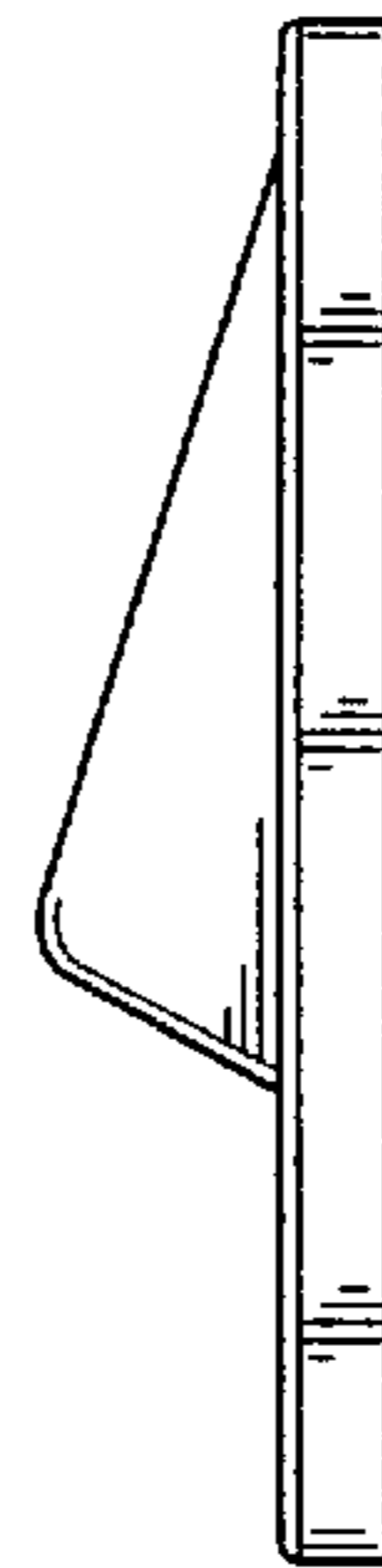
**FIG. 3.**



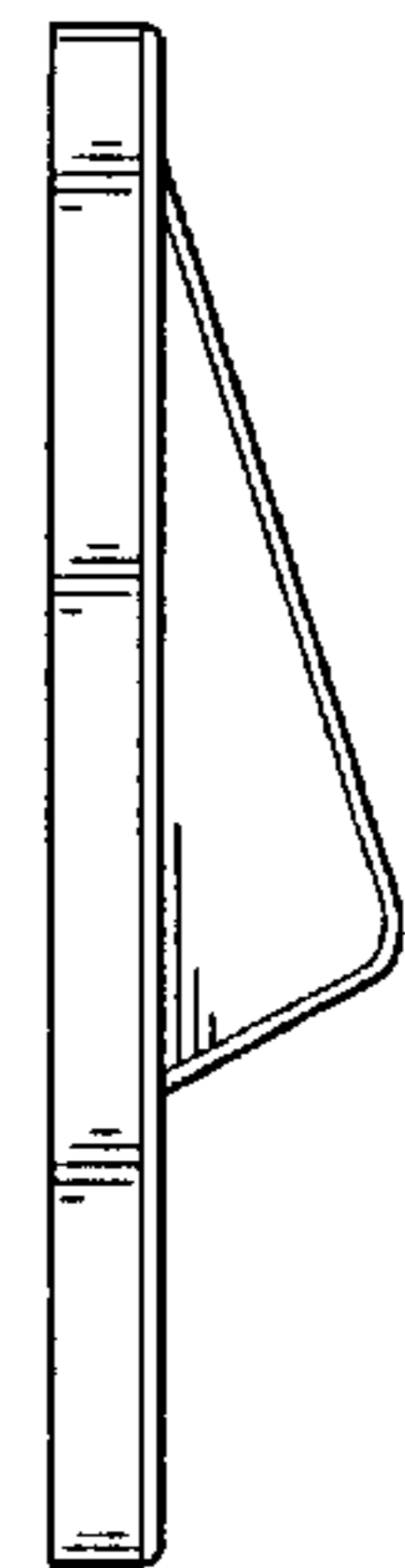
**FIG. 4.**



**FIG. 5.**



**FIG. 6.**



**FIG. 7.**