



US00D430095S

United States Patent [19]

Lotson

[11] Patent Number: **Des. 430,095**

[45] Date of Patent: **** Aug. 29, 2000**

[54] **VEHICLE-WHEEL FRONT FACE**

[75] Inventor: **Demetrius Lotson**, Inglewood, Calif.

[73] Assignee: **Mobile Hi-Tech Wheels**, Torrance, Calif.

[**] Term: **14 Years**

[21] Appl. No.: **29/120,269**

[22] Filed: **Mar. 17, 2000**

[51] **LOC (7) Cl.** **12-16**

[52] **U.S. Cl.** **D12/211**

[58] **Field of Search** D12/204-211;
301/37.1, 64.1, 65

[56] **References Cited**

U.S. PATENT DOCUMENTS

- D. 396,839 8/1998 Cullen D12/211
- D. 399,470 10/1998 Sacco et al. D12/209
- D. 408,778 4/1999 Neeper D12/211

- D. 413,852 9/1999 Cullen D12/209
- D. 416,848 11/1999 Bernoni D12/209
- D. 422,258 4/2000 Hale, Jr. D12/209
- D. 423,442 4/2000 Hussaini et al. D12/209
- D. 425,007 5/2000 Noriega D12/211

Primary Examiner—Stacia Cadmus
Attorney, Agent, or Firm—Christie, Parker & Hale, LLP

[57] **CLAIM**

The ornamental design for a vehicle-wheel front face, as shown and described.

DESCRIPTION

FIG. 1 is a perspective view of a vehicle-wheel front face according to my new design; FIG. 2 is a front elevational view thereof; and, FIG. 3 is a side elevational view thereof. Portions of the wheel depicted in broken lines are for illustrative purposes only, and form no part of the claimed design.

1 Claim, 3 Drawing Sheets

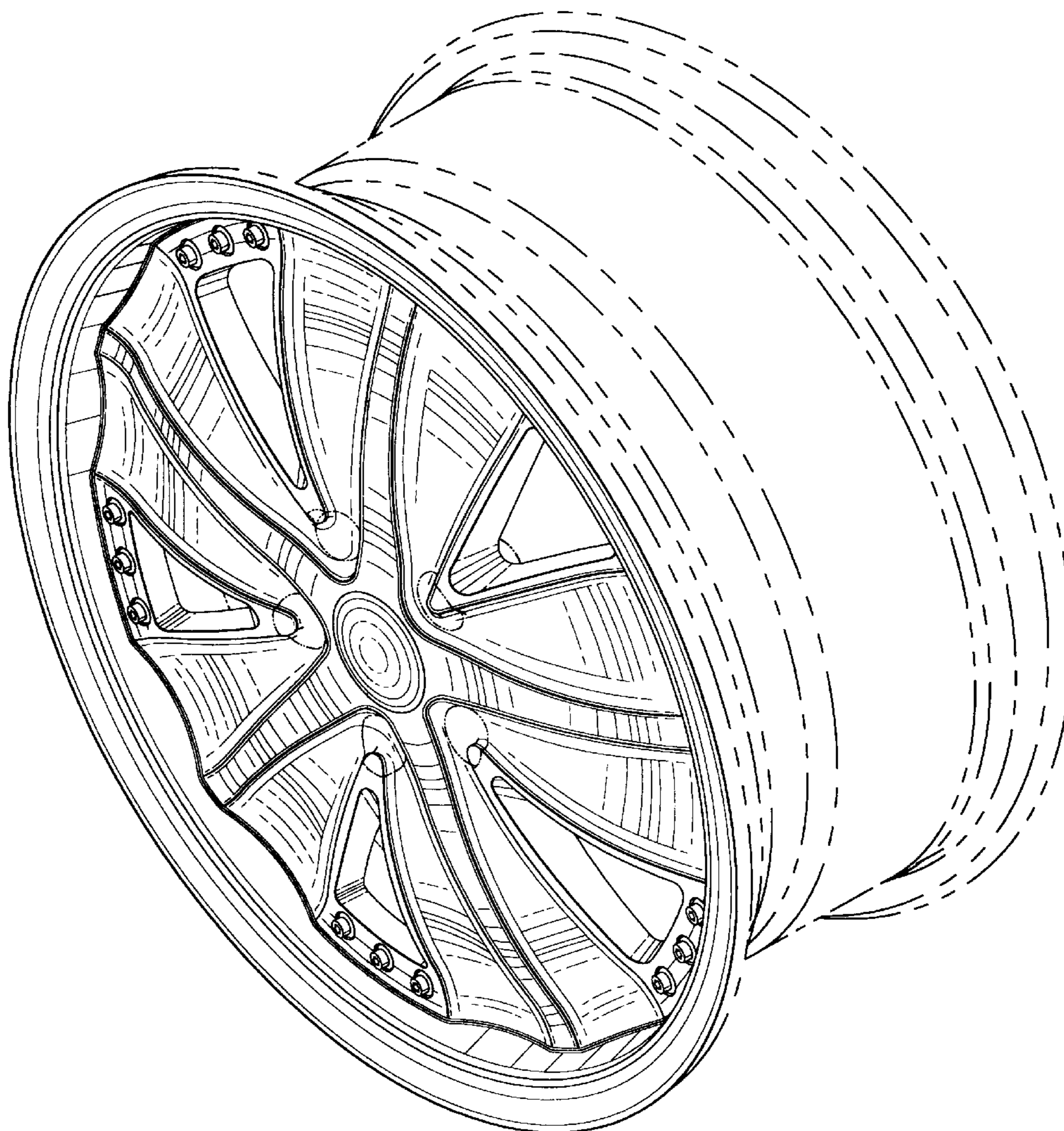

FIG. 1

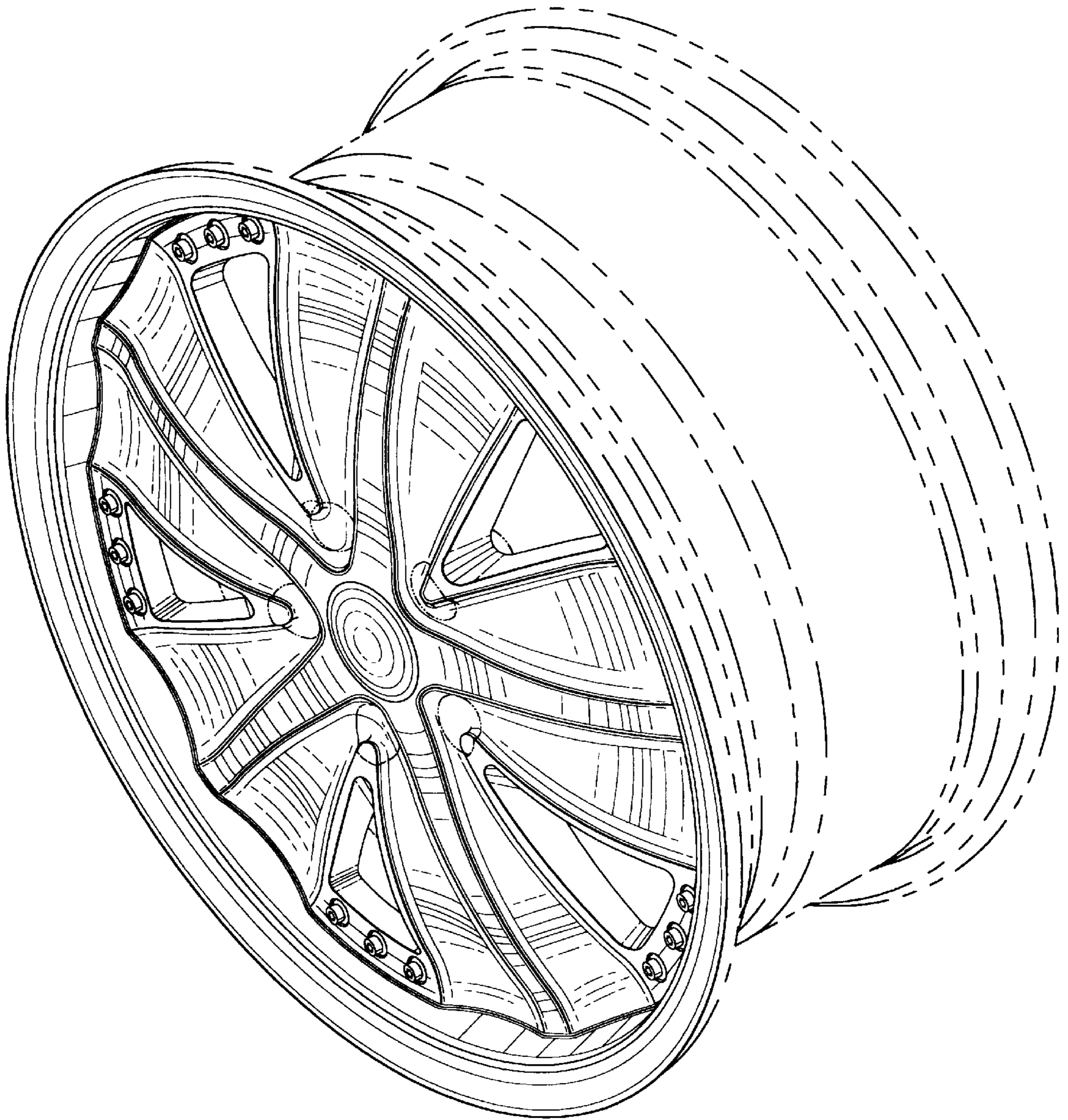

FIG. 2

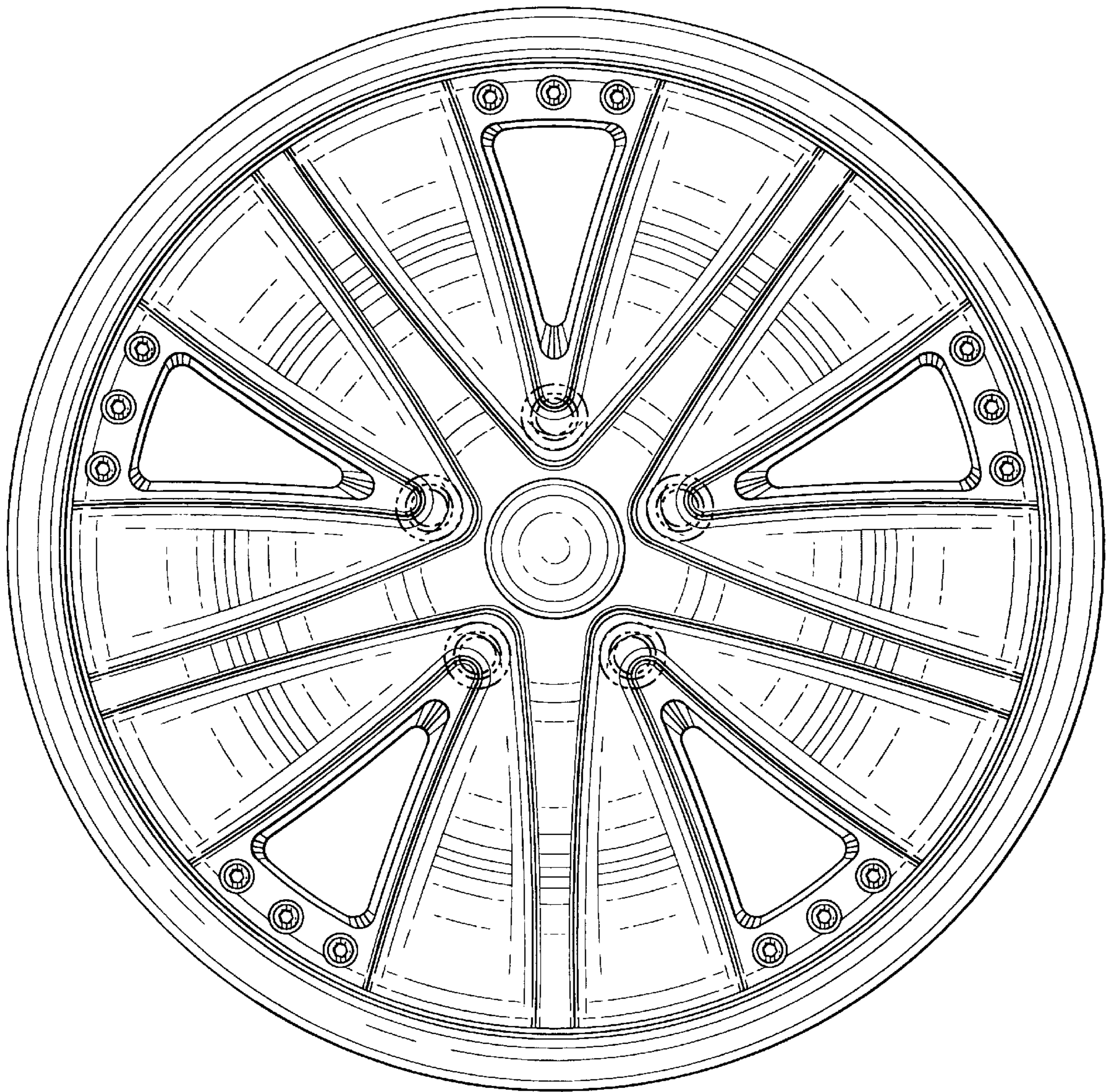

FIG. 3

