



US00D430094S

**United States Patent** [19]  
**Hale, Jr.**

[11] **Patent Number: Des. 430,094**

[45] **Date of Patent: \*\* Aug. 29, 2000**

[54] **VEHICLE-WHEEL FRONT FACE**

[75] Inventor: **Arthur D. Hale, Jr.**, Long Beach, Calif.

[73] Assignee: **Mobile Hi-Tech Wheels**, Torrance, Calif.

[\*\*] Term: **14 Years**

[21] Appl. No.: **29/122,229**

[22] Filed: **Apr. 21, 2000**

[51] **LOC (7) Cl.** ..... **12-16**

[52] **U.S. Cl.** ..... **D12/210**

[58] **Field of Search** ..... D12/204-211;  
301/37.1, 64.1, 65

[56] **References Cited**

**U.S. PATENT DOCUMENTS**

D. 108,775	3/1938	Burger	.....	D12/210
D. 194,099	11/1962	Walsh	.....	D12/210
D. 219,967	2/1971	Harty	.....	D12/210
D. 361,975	9/1995	Weld	.....	D12/210
D. 398,274	9/1998	Hartmann, Jr.	.....	D12/209
D. 407,363	3/1999	Muzzarelli	.....	D12/209
D. 411,501	6/1999	Cullen	.....	D12/209
D. 412,309	7/1999	Stacy	.....	D12/209

D. 413,852	9/1999	Cullen	.....	D12/209
D. 416,846	11/1999	Melegari et al.	.....	D12/209
D. 423,442	4/2000	Hussaini et al.	.....	D12/209
D. 425,470	5/2000	Pfeiffer et al.	.....	D12/209

*Primary Examiner*—Stacia Cadmus  
*Attorney, Agent, or Firm*—Christie, Parker & Hale, LLP

[57] **CLAIM**

The ornamental design for a vehicle-wheel front face, as shown and described.

**DESCRIPTION**

FIG. 1 is a perspective view of a vehicle-wheel front face according to my new design;  
FIG. 2 is a front elevational view thereof;  
FIG. 3 is a side elevational view thereof;  
FIG. 4 is a perspective view of a vehicle-wheel front face showing a second embodiment of my new design, including an alternative center cap;  
FIG. 5 is a front elevational view of the second embodiment; and,  
FIG. 6 is a side elevation of the second embodiment.  
Portions of the wheel depicted in broken line are for illustrative purposes only, and form no part of the claimed design.

**1 Claim, 6 Drawing Sheets**

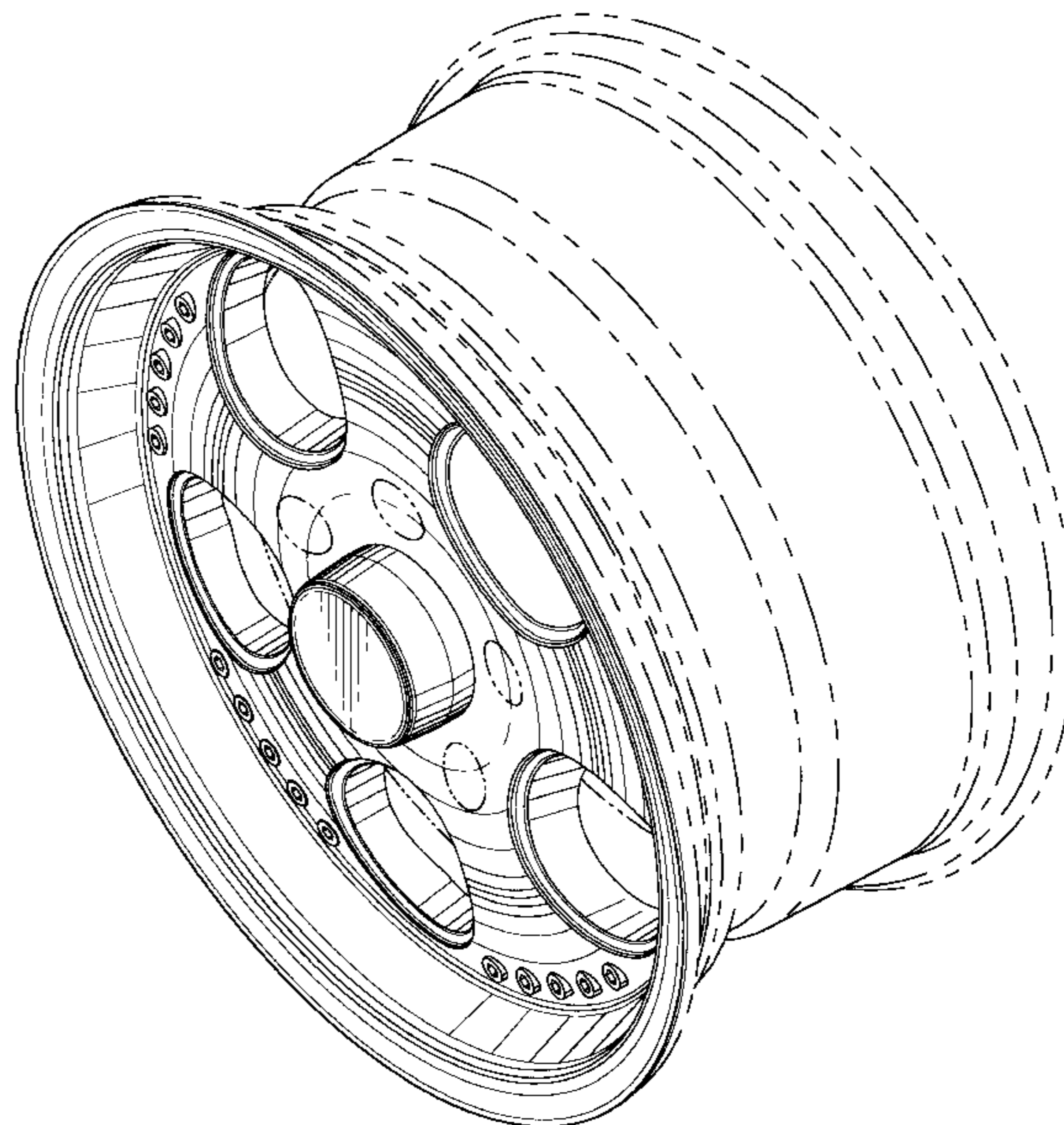
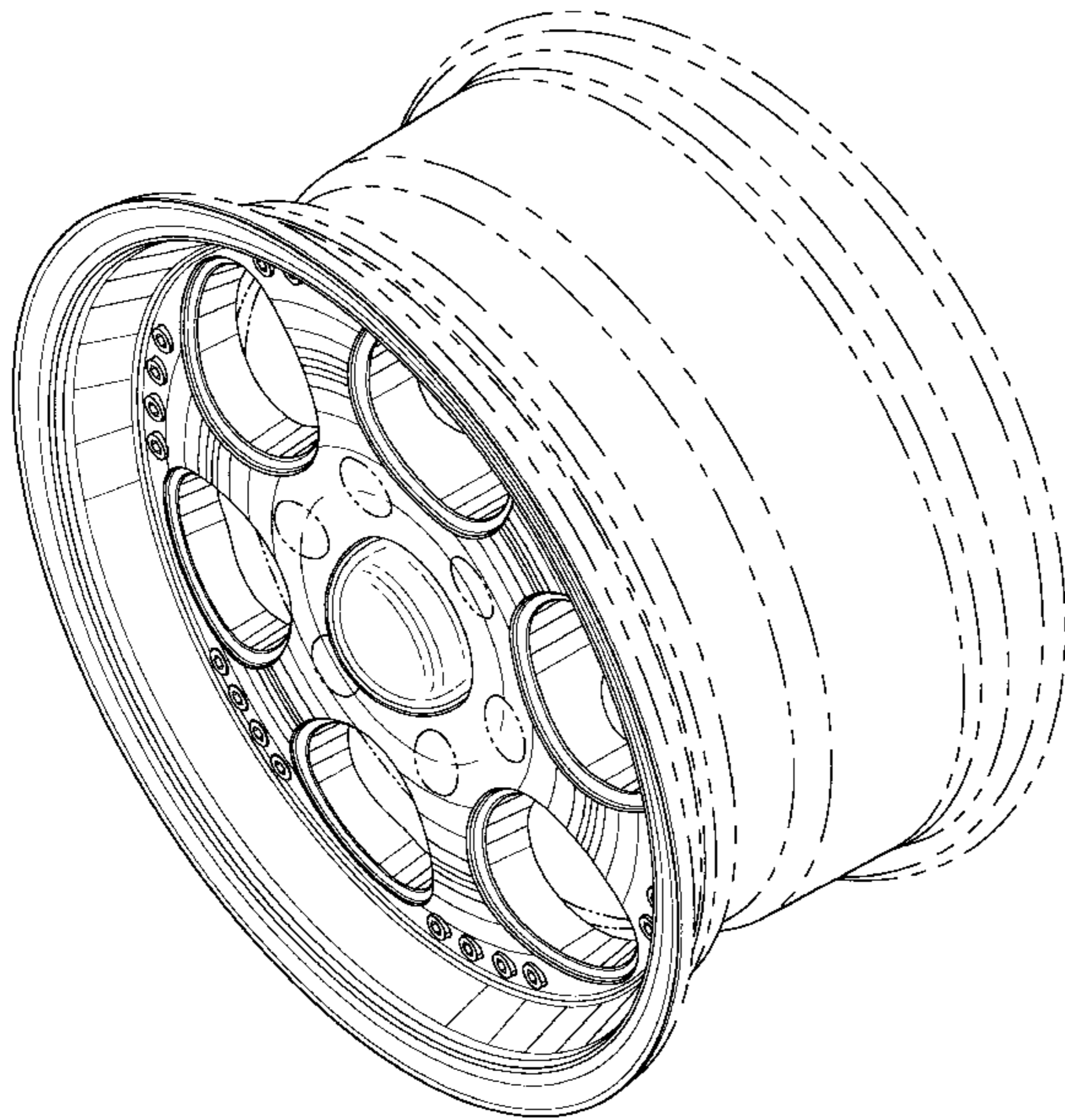

*FIG. 1*

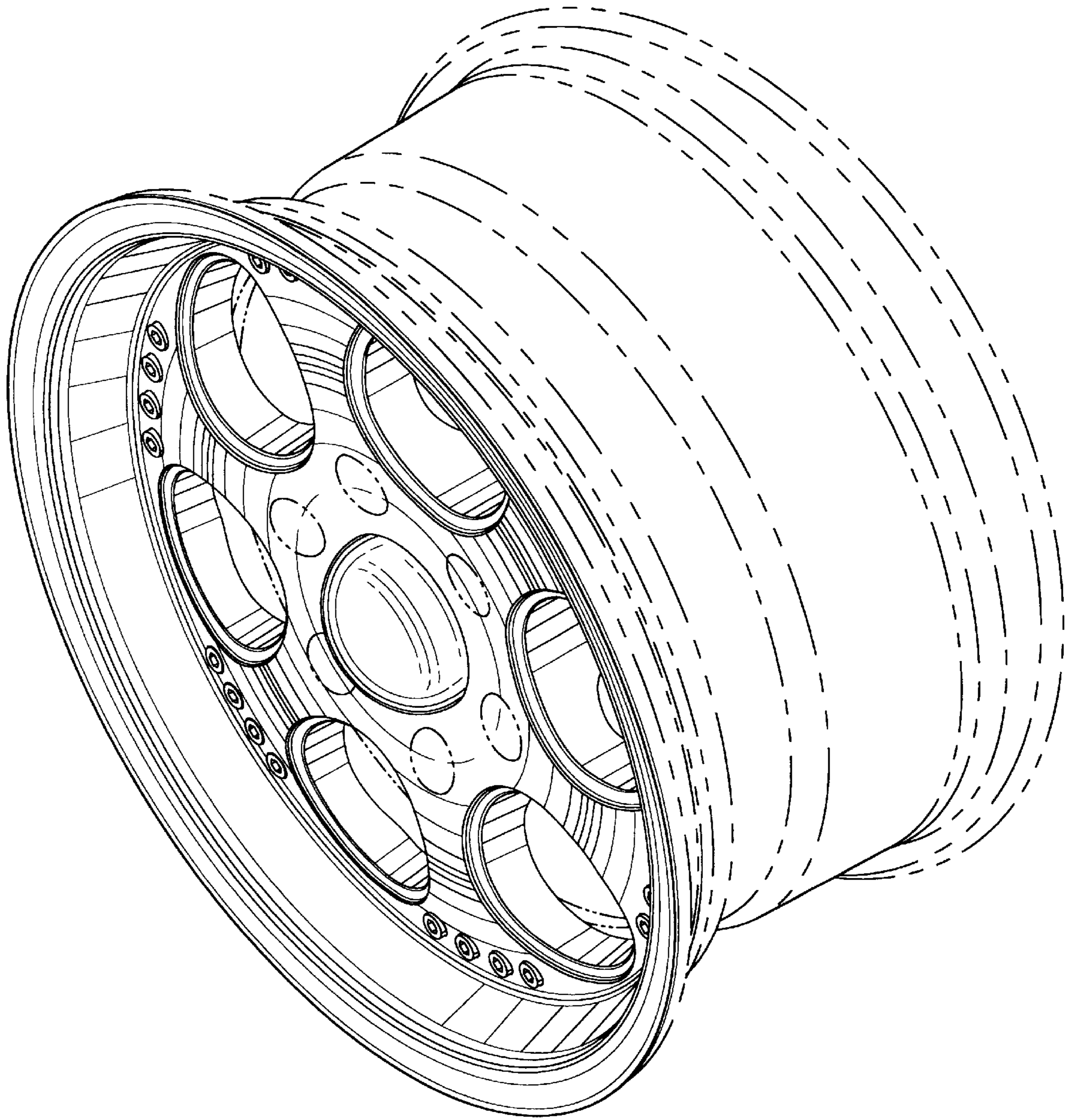

*FIG. 2*

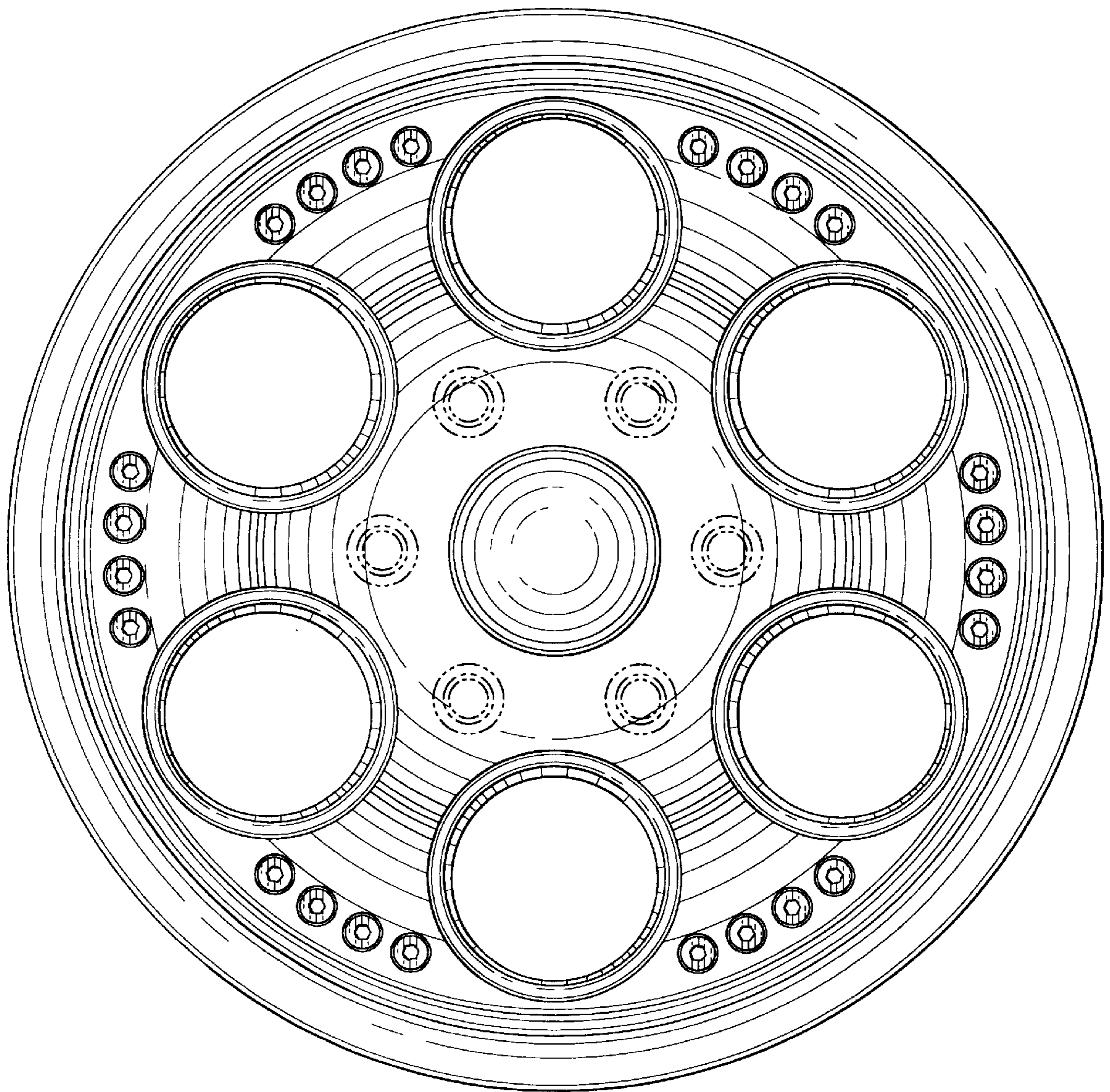

*FIG. 3*

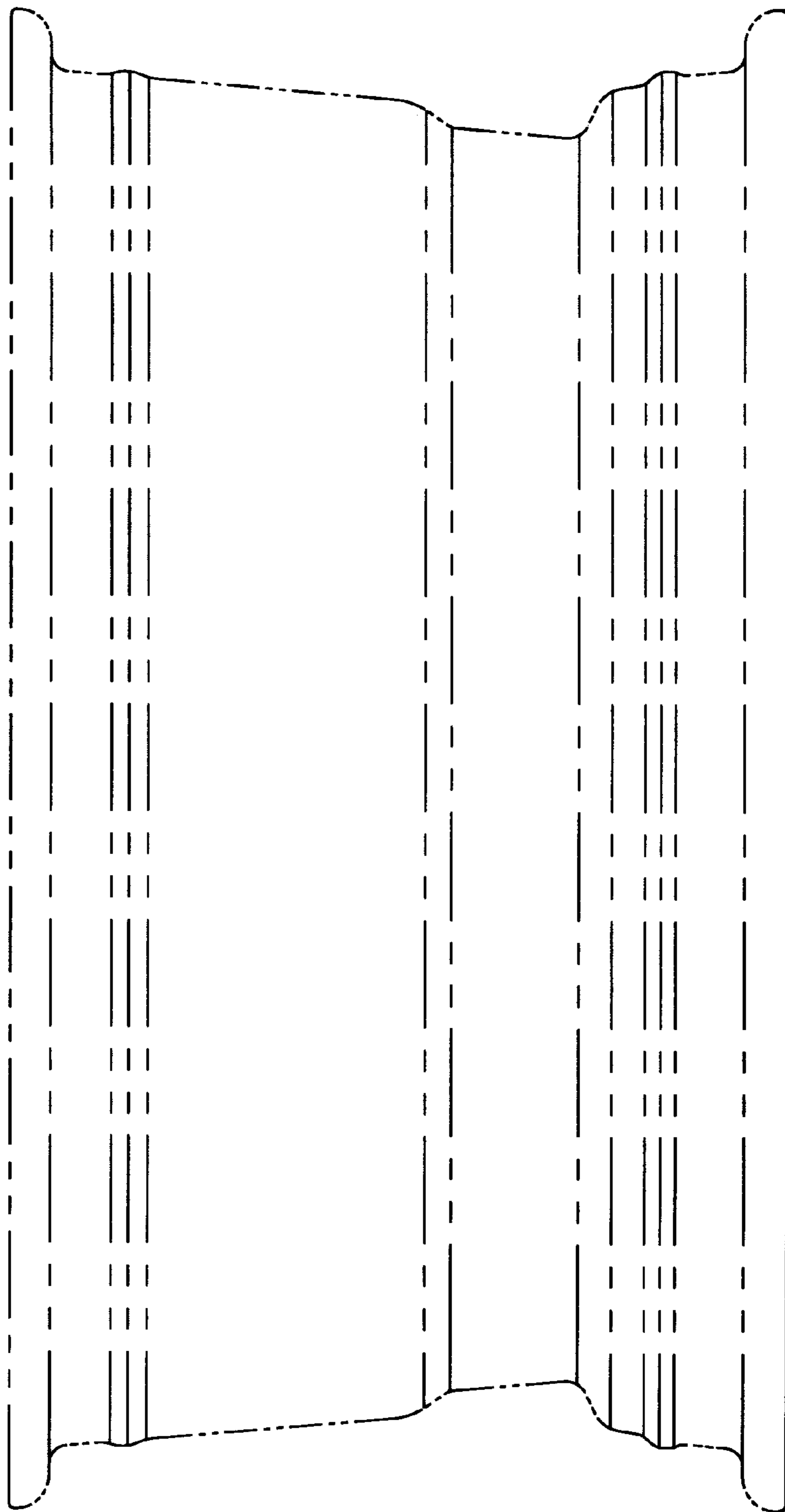

*FIG. 4*

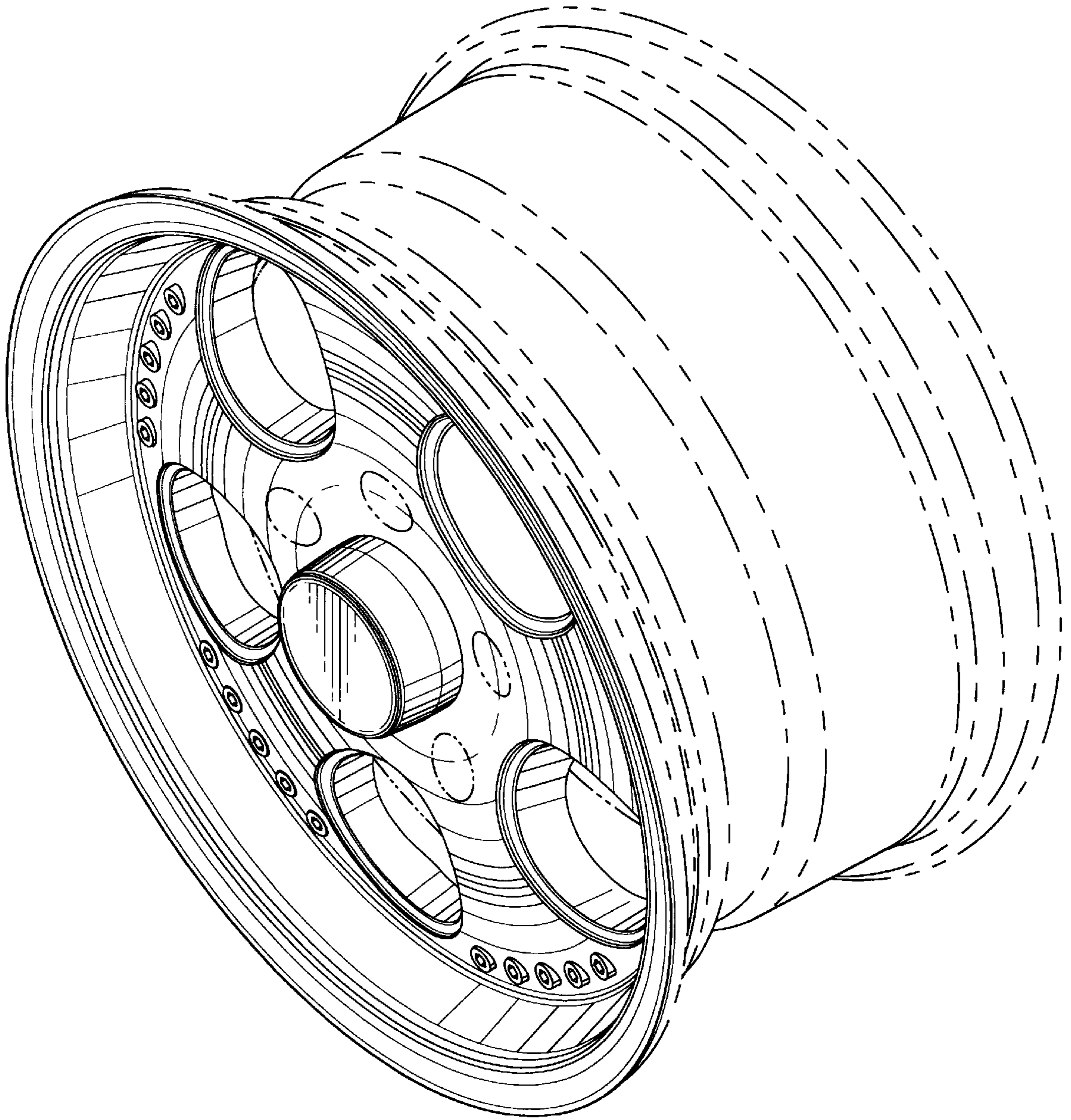

*FIG. 5*

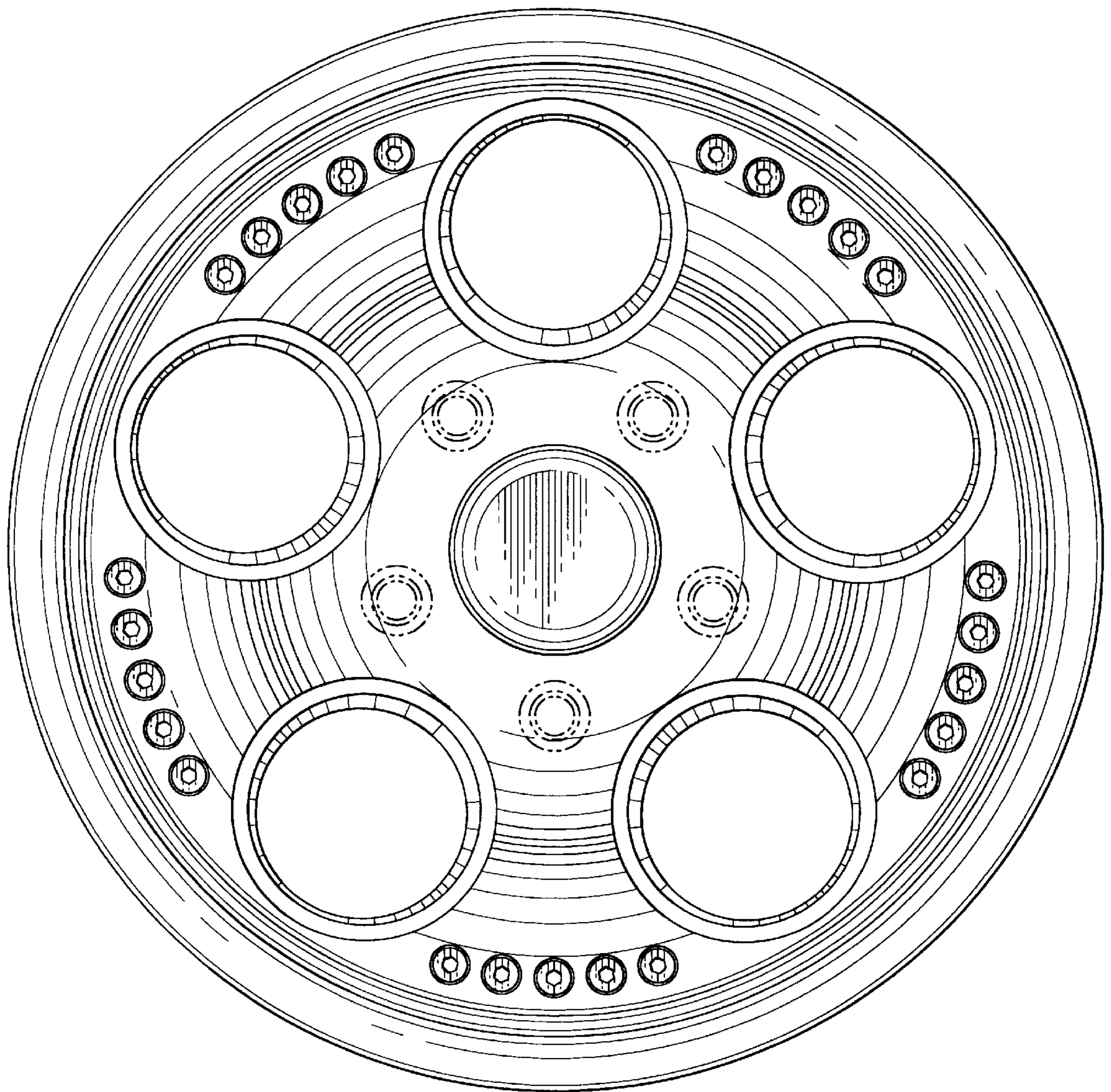

*FIG. 6*

