



US00D429735S

United States Patent [19]

[11] Patent Number: Des. 429,735

Versaw, Jr. et al.

[45] Date of Patent: ** Aug. 22, 2000

[54] **INTEGRALLY FORMED TANK SUMP WITH LID**

[75] Inventors: **Robert H. Versaw, Jr.; James W. Mosier**, both of Muskegon; **Daniel P. Nordstrom**, Twin Lake, all of Mich.

[73] Assignee: **Advanced Polymer Technology, Inc.**, Muskegon, Mich.

[**] Term: **14 Years**

[21] Appl. No.: **29/091,118**

[22] Filed: **Jul. 23, 1998**

Related U.S. Application Data

[63] Continuation-in-part of application No. 29/083,576, Feb. 12, 1998, Pat. No. Des. 404,742.

[51] **LOC (7) Cl.** **15-02**

[52] **U.S. Cl.** **D15/7**

[58] **Field of Search** D15/7-9; 310/87; 73/40, 40.1, 40.5 R, 49.2, 49.5; 285/21; 137/565, 312; 417/411, 424.1, 423.3, 434, 367, 234; 415/199.2

[56] References Cited

U.S. PATENT DOCUMENTS

- D. 309,308 7/1990 Webb .
- D. 313,418 1/1991 Webb .

(List continued on next page.)

FOREIGN PATENT DOCUMENTS

- 150132 5/1951 Australia .
- 200618 10/1955 Australia .
- 1068961 1/1980 Canada .
- 2047354 1/1992 Canada .
- 0944434 11/1948 France .
- 1496531 9/1967 France .
- 0951281 10/1956 Germany .
- 2253857 5/1973 Germany .
- 2226508 12/1973 Germany .
- 3016401 2/1981 Germany .
- 3-51430 3/1991 Japan .

- 0245418 6/1969 Russian Federation .
- 1352272 11/1987 Russian Federation .
- 0424638 5/1967 Switzerland .
- 0209931 1/1924 United Kingdom .
- 0595584 12/1947 United Kingdom .
- 0632756 12/1949 United Kingdom .
- 0667165 2/1952 United Kingdom .
- 1087178 10/1967 United Kingdom .
- 1144475 3/1969 United Kingdom .
- WO 90/04157 4/1990 WIPO .
- WO 90/07074 6/1990 WIPO .
- WO 93/17266 9/1993 WIPO .
- WO 95/09998 4/1995 WIPO .

OTHER PUBLICATIONS

- Total Containment Inc., *Multisided Tank Sumps* (Jul. 1, 1994).
- Total Containment Inc., *Sump/Risers*.
- Total Containment Inc., *Sump/Risers—Installation Instructions* (Apr. 15, 1989).
- Total Containment Inc., *Sump/Riser Installation Instructions for Single Access Lids* (Nov. 23, 1992).
- Total Containment Inc., *Enviroflex—Flexible Double-Wall Piping System* (Mar. 1, 1991).
- Environ Products Inc., *Environ Safe Products—Designed for Future Generations* (1993).

(List continued on next page.)

Primary Examiner—Ralf Seifert
Attorney, Agent, or Firm—Young & Basile, P.C.

[57] CLAIM

The ornamental design for an integrally formed tank sump with lid, as shown and described,

DESCRIPTION

FIG. 1 is an isometric view embodying the ornamental design constituting our invention; FIG. 2 is a top plan view thereof; FIG. 3 is a front elevational view thereof, which is identical to the rear elevational view; FIG. 4 is a bottom plan view thereof; and, FIG. 5 is a right-side elevational view thereof, which is identical to the left-side elevational view.

1 Claim, 3 Drawing Sheets

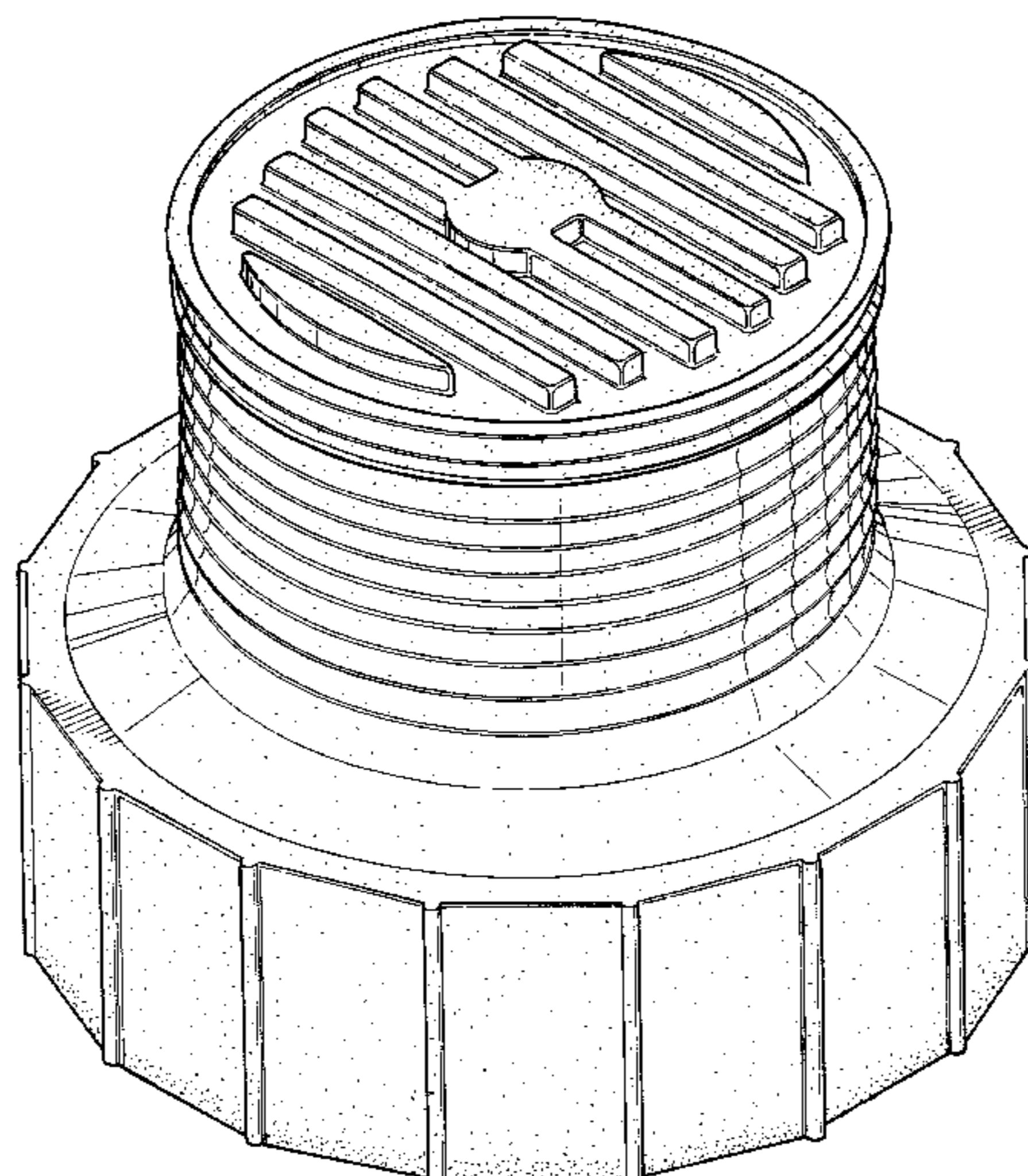

U.S. PATENT DOCUMENTS					
			4,309,128	1/1982	Williams .
			4,327,925	5/1982	Alexander et al. .
			4,365,829	12/1982	Fowler .
			4,387,900	6/1983	Ditcher et al. .
			4,449,715	5/1984	Gagas .
			4,449,853	5/1984	Mennella et al. .
			4,472,911	9/1984	Jooris et al. .
			4,492,392	1/1985	Woods et al. .
			4,512,148	4/1985	Jacobson .
			4,530,443	7/1985	Gorges .
			4,540,310	9/1985	Ditcher et al. .
			4,552,386	11/1985	Burchette .
			4,568,925	2/1986	Butts .
			4,619,555	10/1986	Skinner et al. .
			4,621,941	11/1986	Ditcher et al. .
			4,639,164	1/1987	Pugnale et al. .
			4,659,251	4/1987	Petter et al. .
			4,667,505	5/1987	Sharp .
			4,685,327	8/1987	Sharp .
			4,696,330	9/1987	Raudman et al. .
			4,702,645	10/1987	Skinner et al. .
			4,709,723	12/1987	Sidaway et al. .
			4,711,365	12/1987	Fomby .
			4,714,095	12/1987	Muller et al. .
			4,717,036	1/1988	Dundas et al. .
			4,731,501	3/1988	Clark et al. .
			4,747,453	5/1988	Howard, Sr. .
			4,763,806	8/1988	Podgers et al. .
			4,767,108	8/1988	Tanaka et al. .
			4,770,317	9/1988	Podgers et al. .
			4,770,562	9/1988	Muller et al. .
			4,775,073	10/1988	Webb .
			4,782,430	11/1988	Robbins et al. .
			4,797,513	1/1989	Ono et al. .
			4,805,444	2/1989	Webb .
			4,809,866	3/1989	Crocker .
			4,870,856	10/1989	Sharp .
			4,871,084	10/1989	Robbins .
			4,890,863	1/1990	Westhoff et al. .
			4,896,705	1/1990	Podgers et al. .
			4,905,940	3/1990	Luka .
			4,912,287	3/1990	Ono et al. .
			4,924,923	5/1990	Boehmer et al. .
			4,928,349	5/1990	Oikawa et al. .
			4,932,257	6/1990	Webb .
			4,958,957	9/1990	Berg et al. .
			4,961,670	10/1990	McKenzie et al. .
			4,968,179	11/1990	Frahm .
			4,971,225	11/1990	Bravo .
			4,971,477	11/1990	Webb et al. .
			5,002,428	3/1991	Shettel .
			5,030,033	7/1991	Heintzelman et al. .
			5,039,137	8/1991	Cankovic et al. .
			5,040,408	8/1991	Webb .
			5,054,794	10/1991	Westhoff et al. .
			5,058,633	10/1991	Sharp .
			5,060,509	10/1991	Webb .
			5,062,457	11/1991	Timmons .
			5,076,456	12/1991	Geyer .
			5,085,257	2/1992	Smith .
			5,098,221	3/1992	Osborne .
			5,099,894	3/1992	Mozeley, Jr. .
			5,105,966	4/1992	Fort et al. .
			5,114,271	5/1992	Sunderhaus et al. .
			5,117,877	6/1992	Sharp .
			5,129,428	7/1992	Winter et al. .
			5,129,684	7/1992	Lawrence et al. .
			5,134,878	8/1992	Sharp .
			5,150,927	9/1992	Skinner .
			5,156,292	10/1992	Ross .
			5,209,601	5/1993	Odill et al. .
			5,257,652	11/1993	Lawrence .
D. 322,970	1/1992	Webb .			
D. 351,602	10/1994	Rosenbraugh et al.	D15/7		
845,760	3/1907	Coffin .			
1,317,260	9/1919	Armstrong .			
1,582,191	4/1926	Snooke .			
1,639,495	8/1927	Frame .			
1,712,510	5/1929	Monie .			
1,714,734	5/1929	Skidmore, Jr.	137/565		
1,793,038	2/1931	Zimmermann .			
2,151,770	3/1939	James .			
2,254,668	9/1941	Tomek .			
2,310,877	2/1943	Sperry .			
2,336,150	12/1943	Horvath .			
2,410,999	11/1946	Reisner .			
2,441,009	5/1948	Cunningham .			
2,449,229	9/1948	Hopwood .			
2,671,573	3/1954	Hendon et al. .			
2,688,497	9/1954	Brisack .			
2,691,538	10/1954	Clausen .			
2,717,792	9/1955	Pelley .			
2,813,692	11/1957	Bremer et al. .			
2,870,881	1/1959	Rogge .			
2,906,500	9/1959	Knapp et al. .			
2,911,001	11/1959	Fuller .			
3,010,598	11/1961	Foss .			
3,098,663	7/1963	Dibley .			
3,144,832	8/1964	Haynes	D15/7		
3,178,206	4/1965	Martin et al. .			
3,243,240	3/1966	Arthur .			
3,362,425	1/1968	Morris et al. .			
3,389,560	6/1968	Zemsky .			
3,390,224	6/1968	Wyatt .			
3,401,958	9/1968	Demyon .			
3,408,778	11/1968	Mason .			
3,423,518	1/1969	Weagant .			
3,439,837	4/1969	Hearn et al. .			
3,459,229	8/1969	Croft .			
3,518,359	6/1970	Trimble et al. .			
3,531,264	9/1970	Greipel .			
3,543,377	12/1970	Bremner .			
3,615,034	10/1971	Lemelson .			
3,654,382	4/1972	Rubright .			
3,707,852	1/1973	Burckhardt et al. .			
3,712,009	1/1973	Campagna .			
3,715,958	2/1973	Crawford et al. .			
3,721,270	3/1973	Wittgenstein .			
3,759,280	9/1973	Swanson .			
3,802,456	4/1974	Wittgenstein .			
3,858,752	1/1975	Marvin, Jr. et al. .			
3,859,802	1/1975	Platner et al. .			
3,882,976	5/1975	Nash .			
3,905,405	9/1975	Fowler et al. .			
3,938,285	2/1976	Gilbu .			
3,972,440	8/1976	Warren .			
3,995,332	12/1976	Forchini et al. .			
3,997,760	12/1976	Salinger .			
4,062,376	12/1977	McGrath .			
4,076,040	2/1978	Alpers et al. .			
4,082,301	4/1978	Salinger .			
4,089,139	5/1978	Moffa et al. .			
4,109,976	8/1978	Koch .			
4,132,083	1/1979	McGrath .			
4,145,075	3/1979	Holzmann .			
4,182,581	1/1980	Uehara et al. .			
4,215,868	8/1980	Skinner et al. .			
4,230,234	10/1980	Taylor .			
4,249,758	2/1981	Harris .			
4,262,166	4/1981	Radzishvsky et al. .			
4,275,757	6/1981	Singer .			
4,291,905	9/1981	Schrock .			

5,263,794 11/1993 Webb .
5,271,518 12/1993 Webb .
5,295,760 3/1994 Rowe .
5,297,896 3/1994 Webb .
5,333,490 8/1994 Webb .
5,366,318 11/1994 Brancher .
5,372,453 12/1994 Argandona .
5,398,976 3/1995 Webb .
5,423,447 6/1995 Youngs .
5,431,457 7/1995 Youngs .
5,481,790 1/1996 Koreis et al. .
5,482,400 1/1996 Bavington .
5,490,419 2/1996 Webb .
5,501,472 3/1996 Brancher et al. .

5,722,699 3/1998 Brancher .

OTHER PUBLICATIONS

Environ Products Inc., Installation Instructions—Deep Burial Sumps (Sep. 1, 1993).
Hofit, *Instructions for the Installation of Hofit Chambers*, pp. A1/17–A17/17.
Owens–Corning Fiberglas, *Piping Sumps—For Secondary Containment of Pumps & Piping* (Installation & Specification), pp. 1–9 (Dec. 1985).
Advanced Polymer Technology Inc., *APT Tech–Notes—Flexible Entry Boot Installation*, Issue 102 (Sep. 1993).

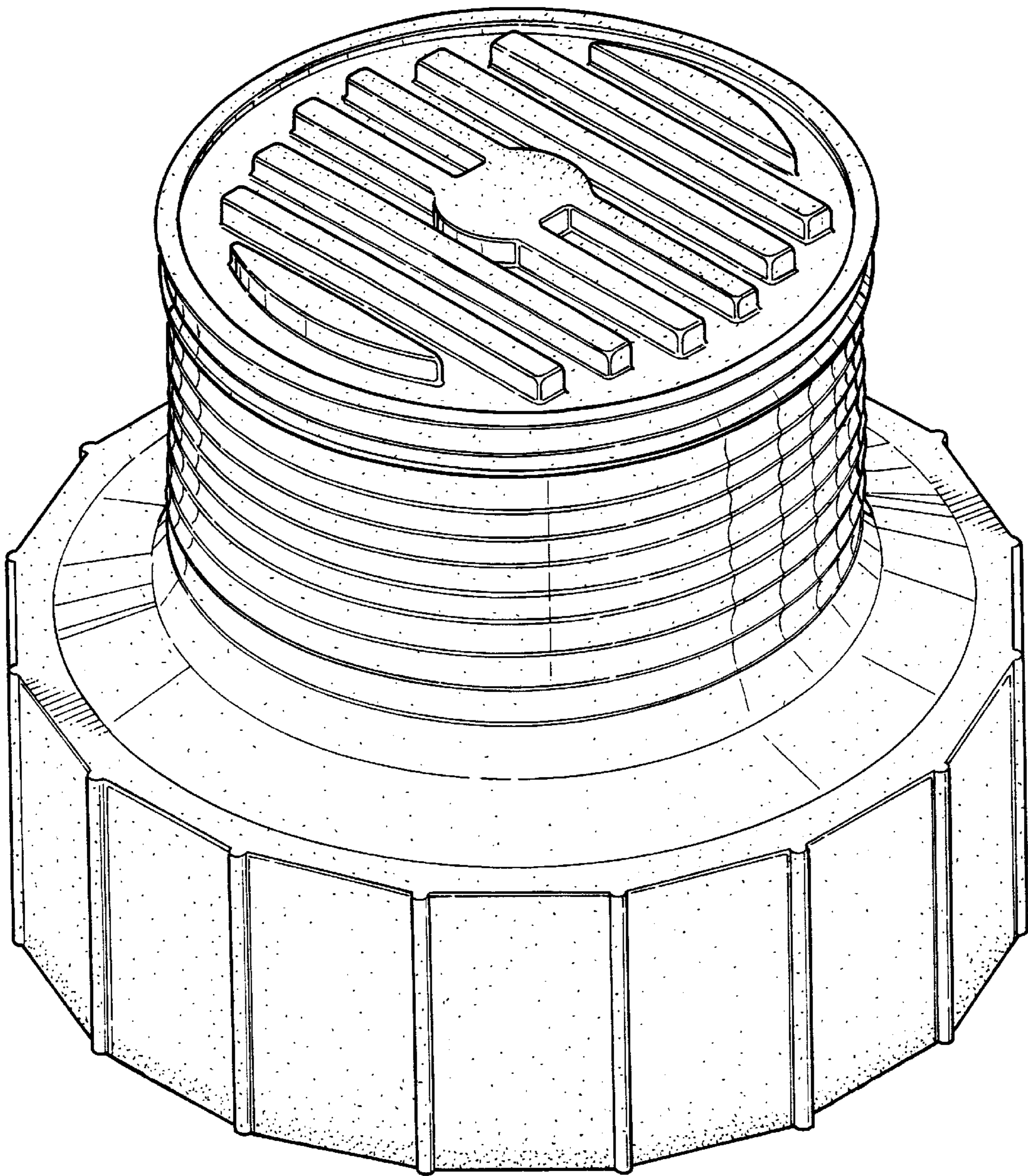

FIG - 1

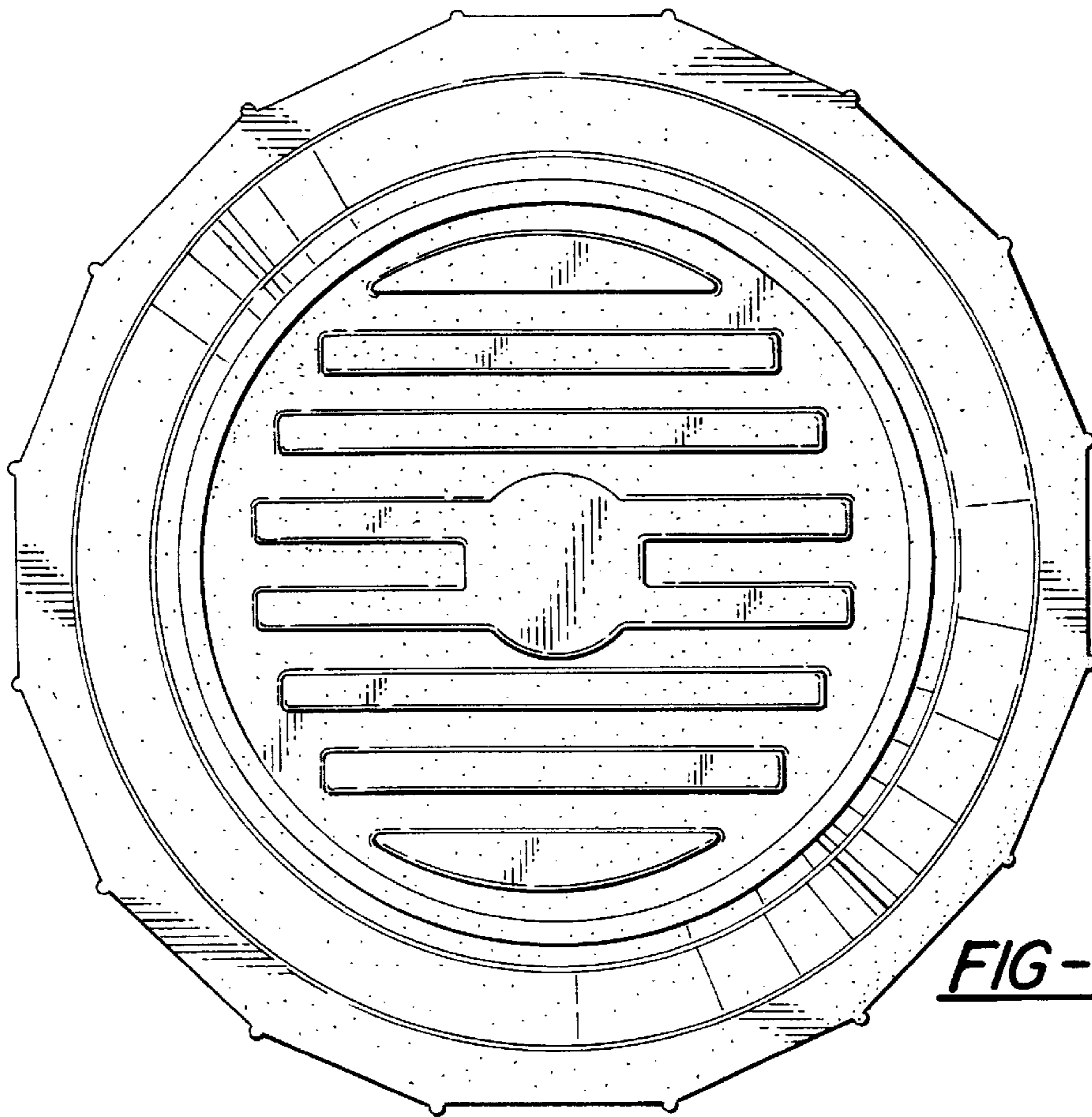

FIG-2

FIG-3

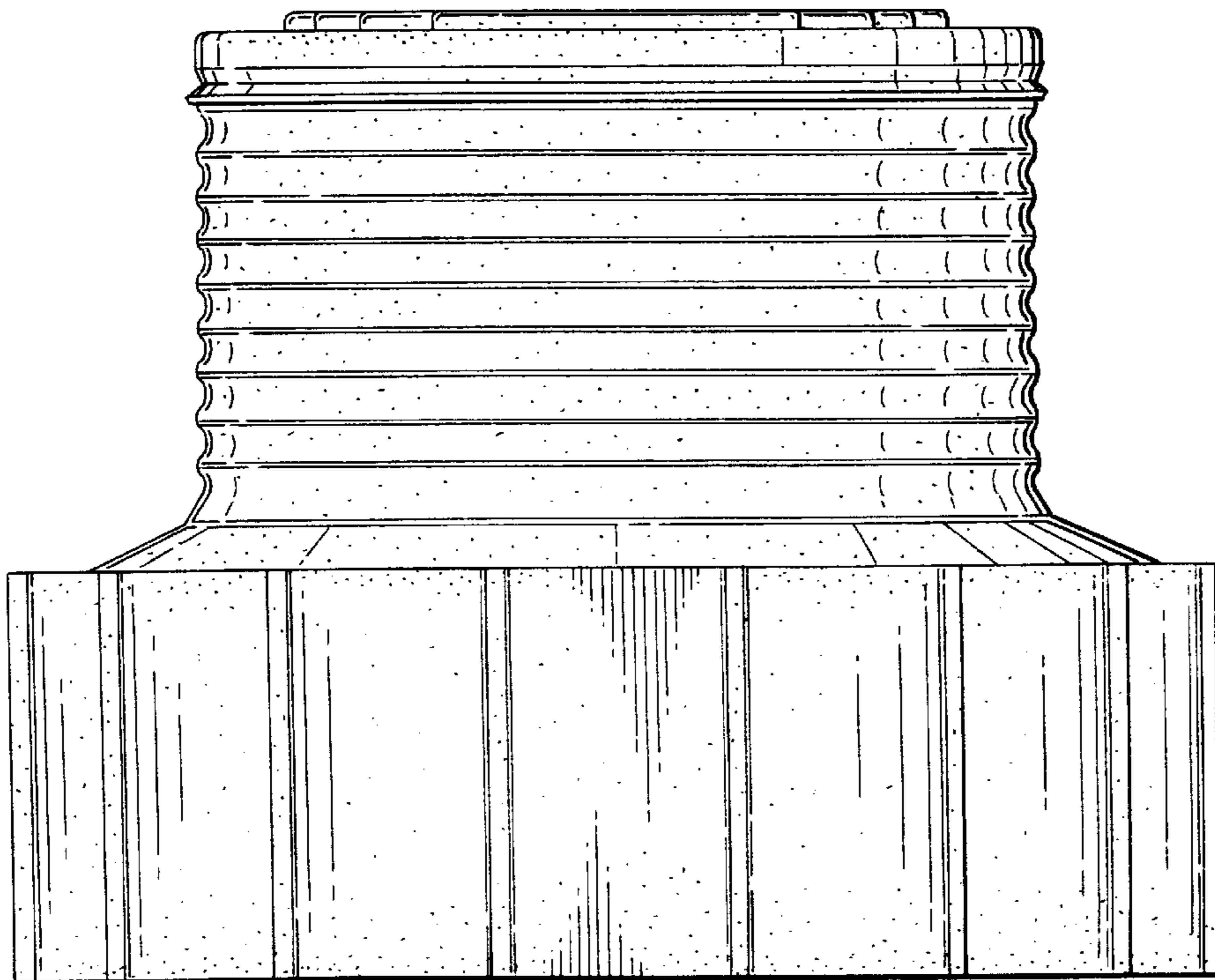

FIG-4

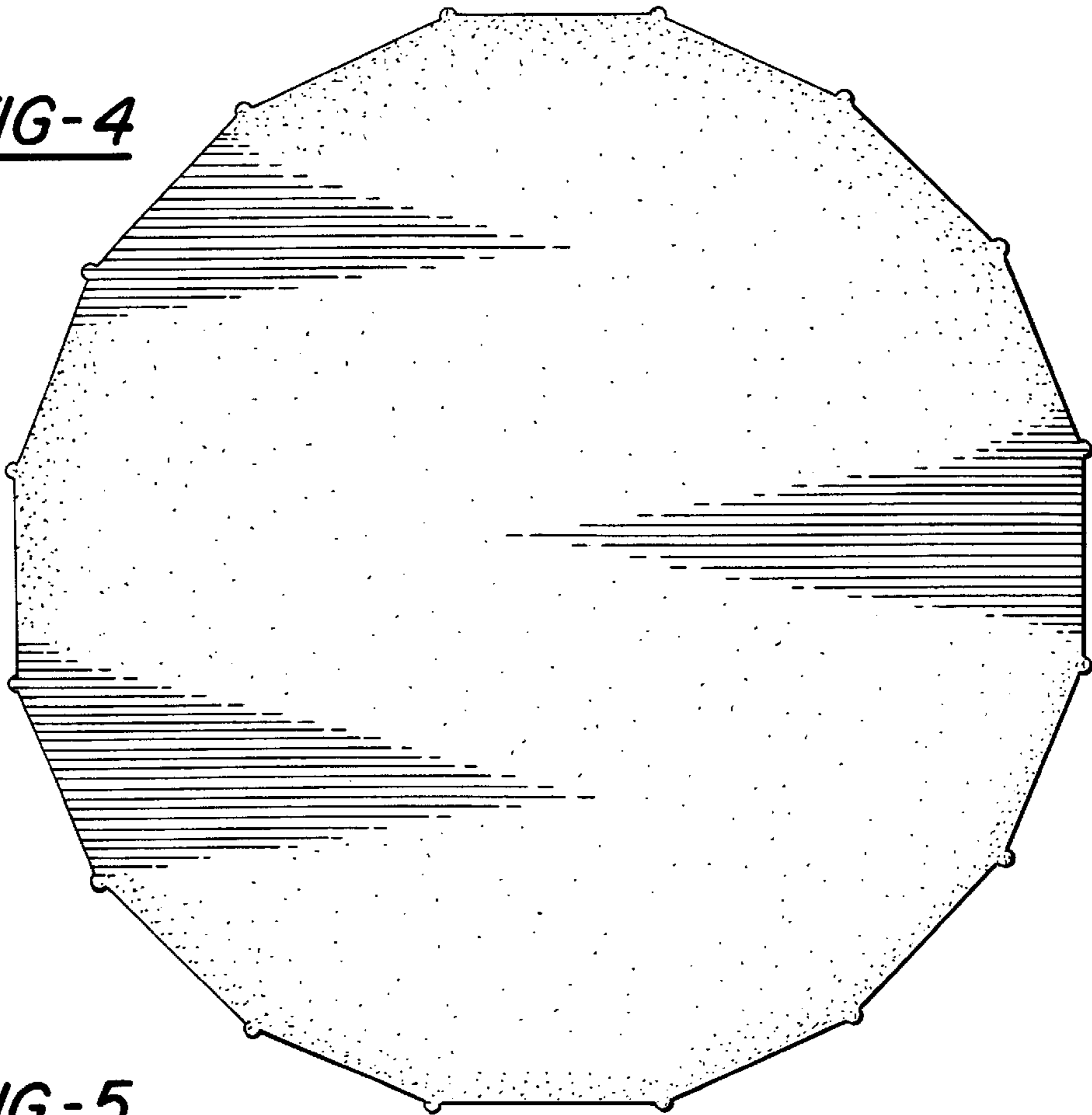

FIG-5

