



US00D429677S

United States Patent [19]
Hayashi

[11] **Patent Number: Des. 429,677**

[45] **Date of Patent: ** Aug. 22, 2000**

[54] **REAR PORTION OF A MOTOR VEHICLE**

[75] Inventor: **Kouichi Hayashi**, Hiroshima, Japan

[73] Assignee: **Mazda Motor Corporation**,
Hiroshima-Ken, Japan

[**] Term: **14 Years**

[21] Appl. No.: **29/102,389**

[22] Filed: **Mar. 24, 1999**

[51] **LOC (7) Cl.** **12-16**

[52] **U.S. Cl.** **D12/196**

[58] **Field of Search** D12/196, 90-92;
296/185

[56] **References Cited**

U.S. PATENT DOCUMENTS

D. 373,342	9/1996	Moore	D12/196
D. 395,619	6/1998	Cho	D12/91
5,449,213	9/1995	Kiley et al.	296/56

Primary Examiner—Melody N. Brown
Attorney, Agent, or Firm—Sidley & Austin; Hugh A. Abrams

[57] **CLAIM**

The ornamental design for a rear portion of a motor vehicle, as shown and described.

DESCRIPTION

FIG. 1 is a perspective view of a first rear portion of a motor vehicle;
FIG. 2 is a front view of the first rear portion;
FIG. 3 is a right side view of the first rear portion;
FIG. 4 is a left side view of the first rear portion;
FIG. 5 is a top view of the first rear portion;
FIG. 6 is a perspective view of a second rear portion of a motor vehicle;
FIG. 7 is a front view of the second rear portion;
FIG. 8 is a right side view of the second rear portion;
FIG. 9 is a left side view of the second rear portion;
FIG. 10 is a top view of the second rear portion;
FIG. 11 is a perspective view of a third rear portion of a motor vehicle;
FIG. 12 is a front view of the third rear portion;
FIG. 13 is a right side view of the third rear portion;
FIG. 14 is a left side view of the third rear portion; and,
FIG. 15 is a top view of the third rear portion.

The portion of the motor vehicle shown in broken lines is for illustrative purposes only and forms no part of the claimed design.

1 Claim, 15 Drawing Sheets

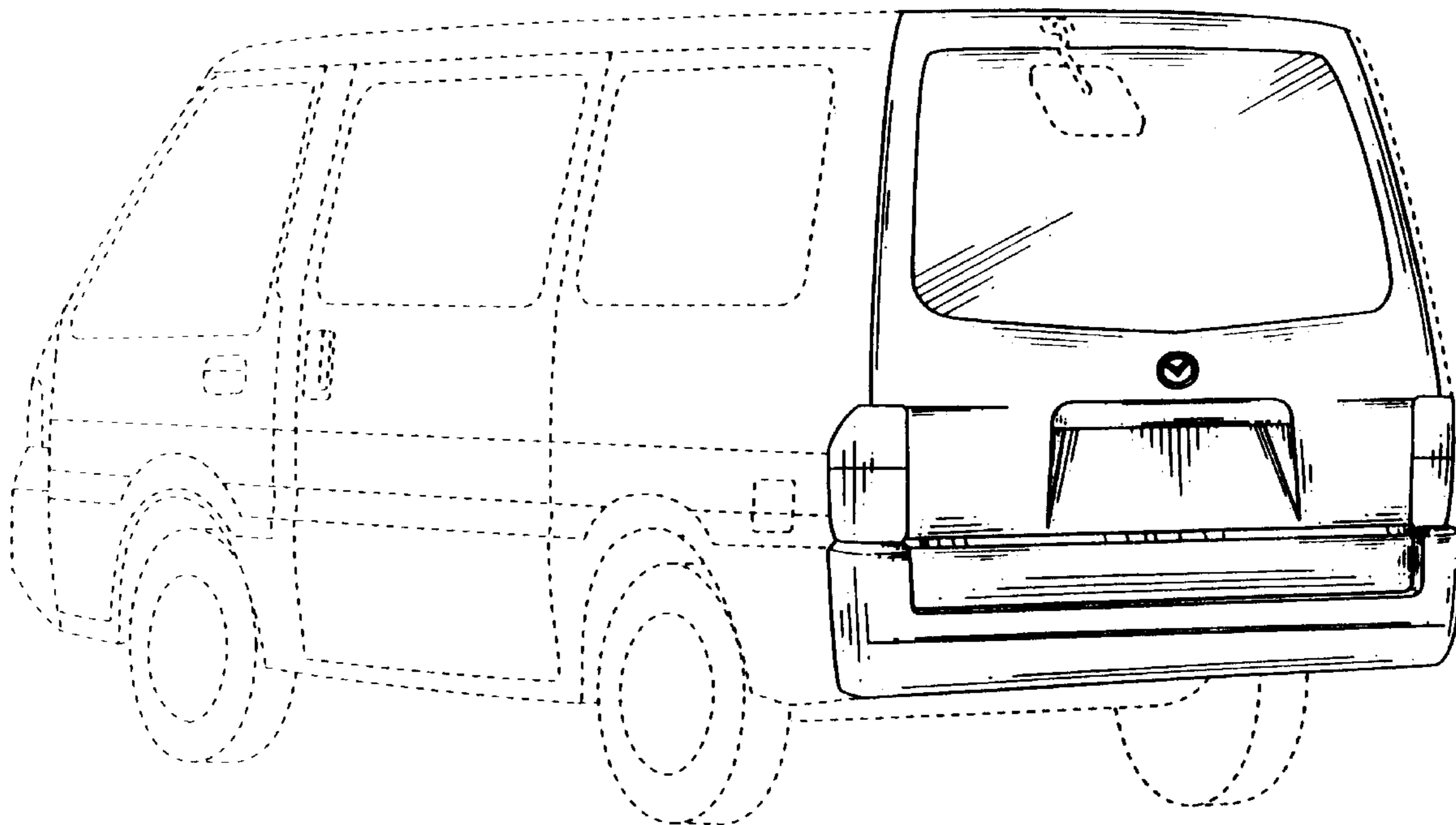

FIG. 1

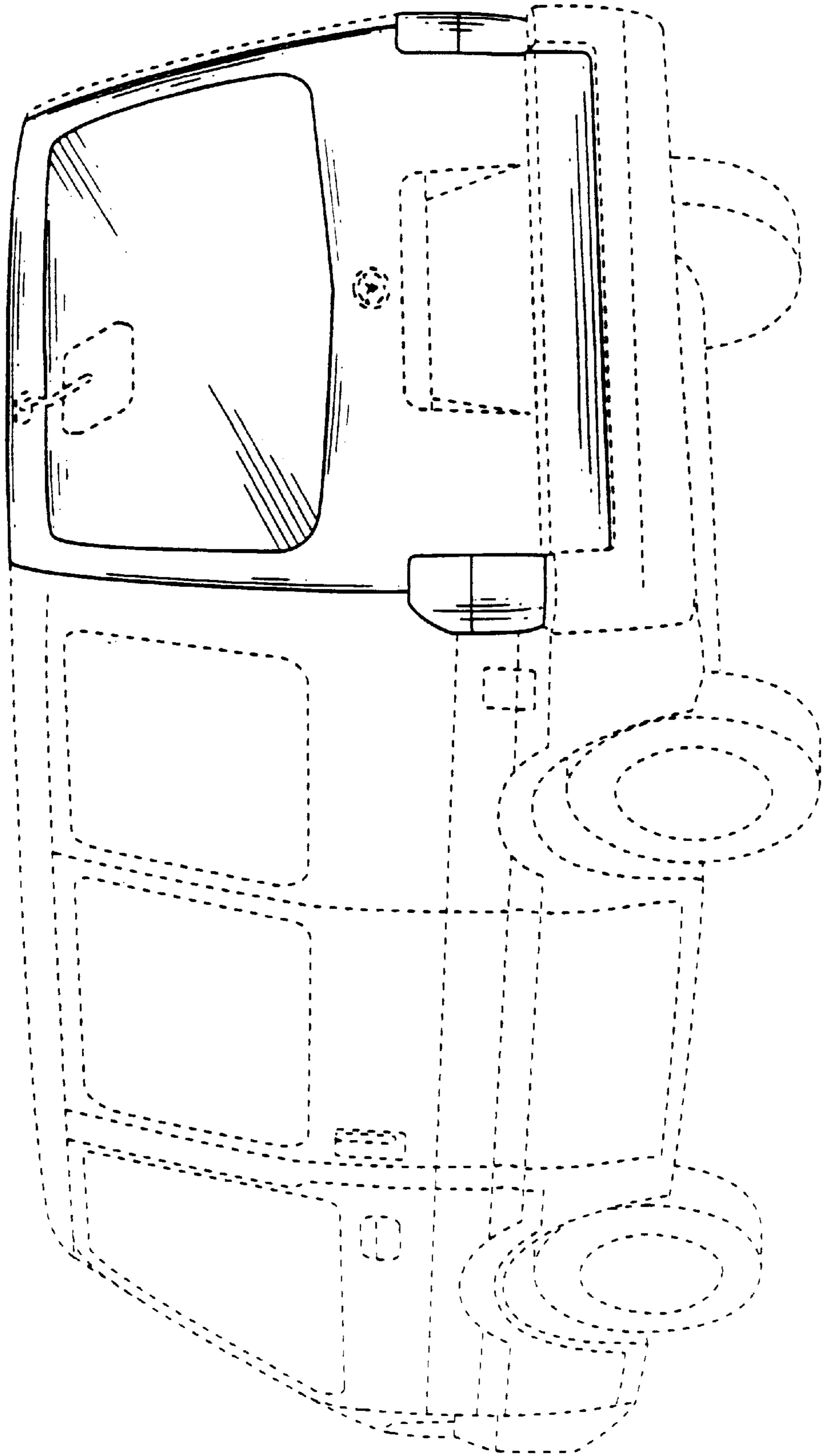

FIG. 2

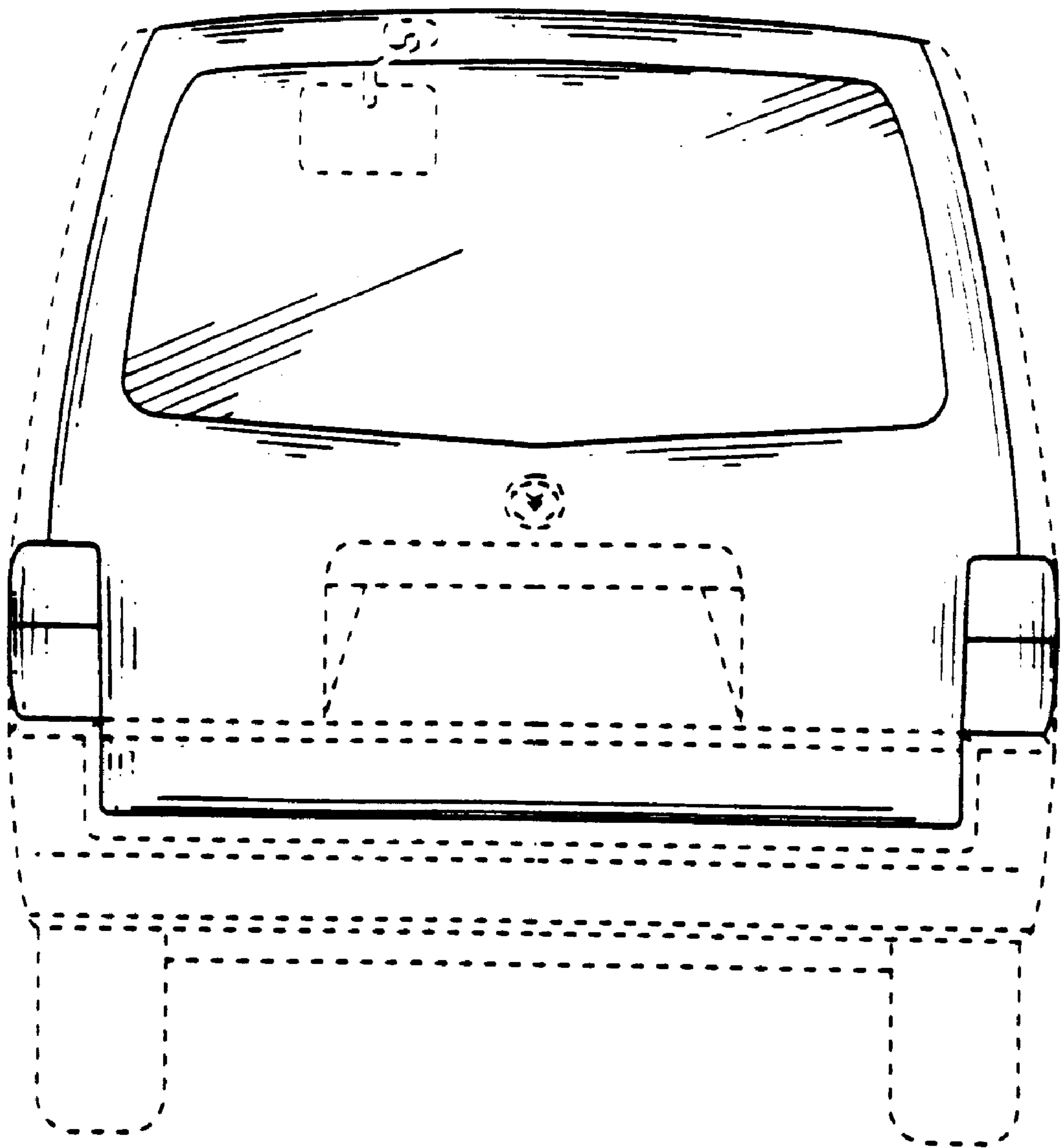

FIG. 3

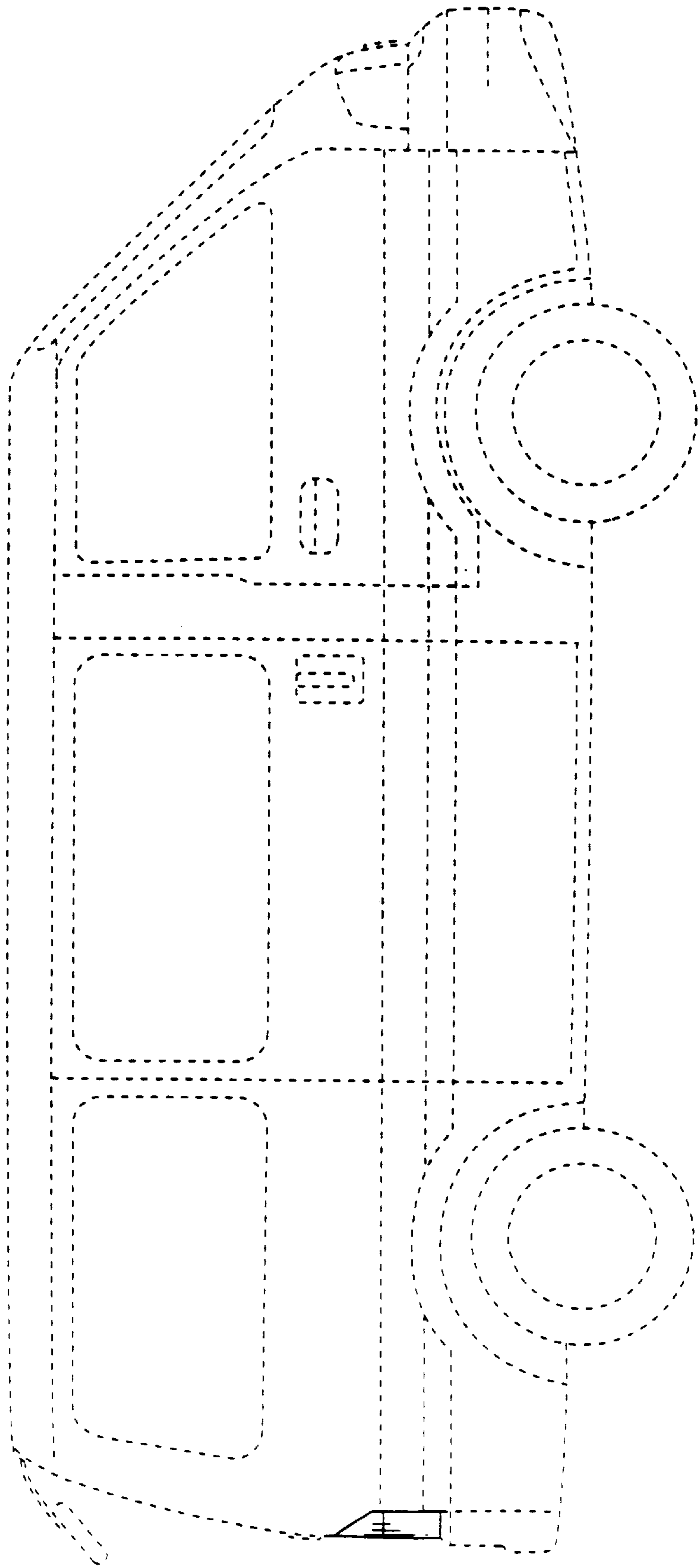

FIG. 4

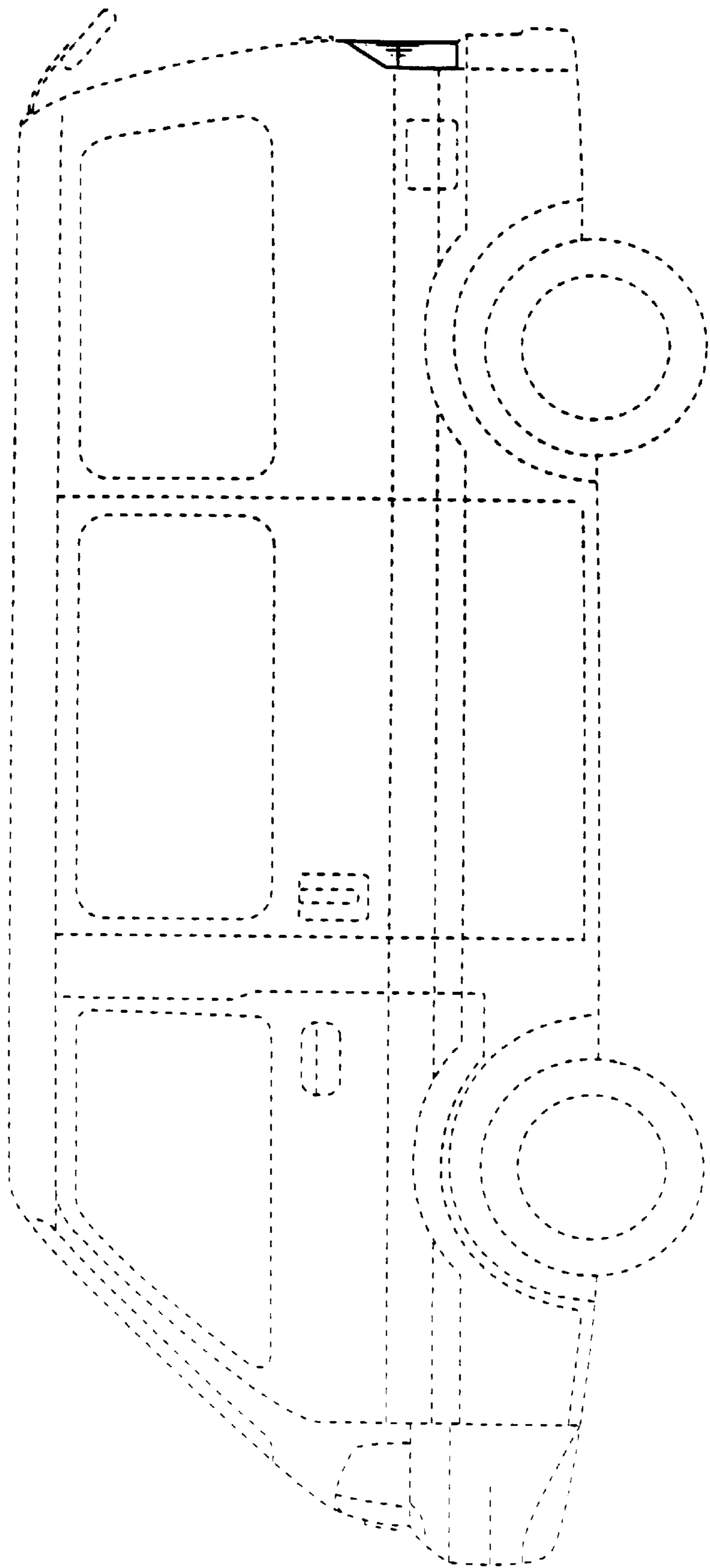

FIG. 5

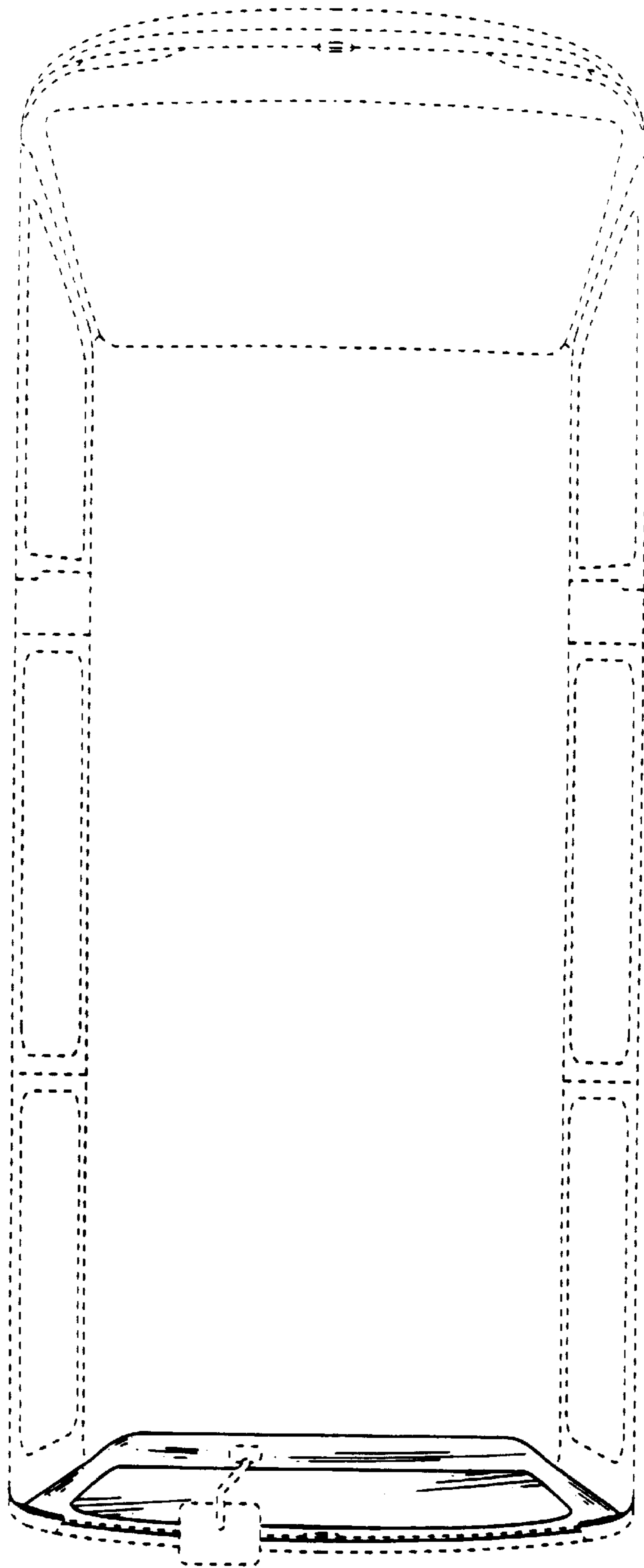

FIG. 6

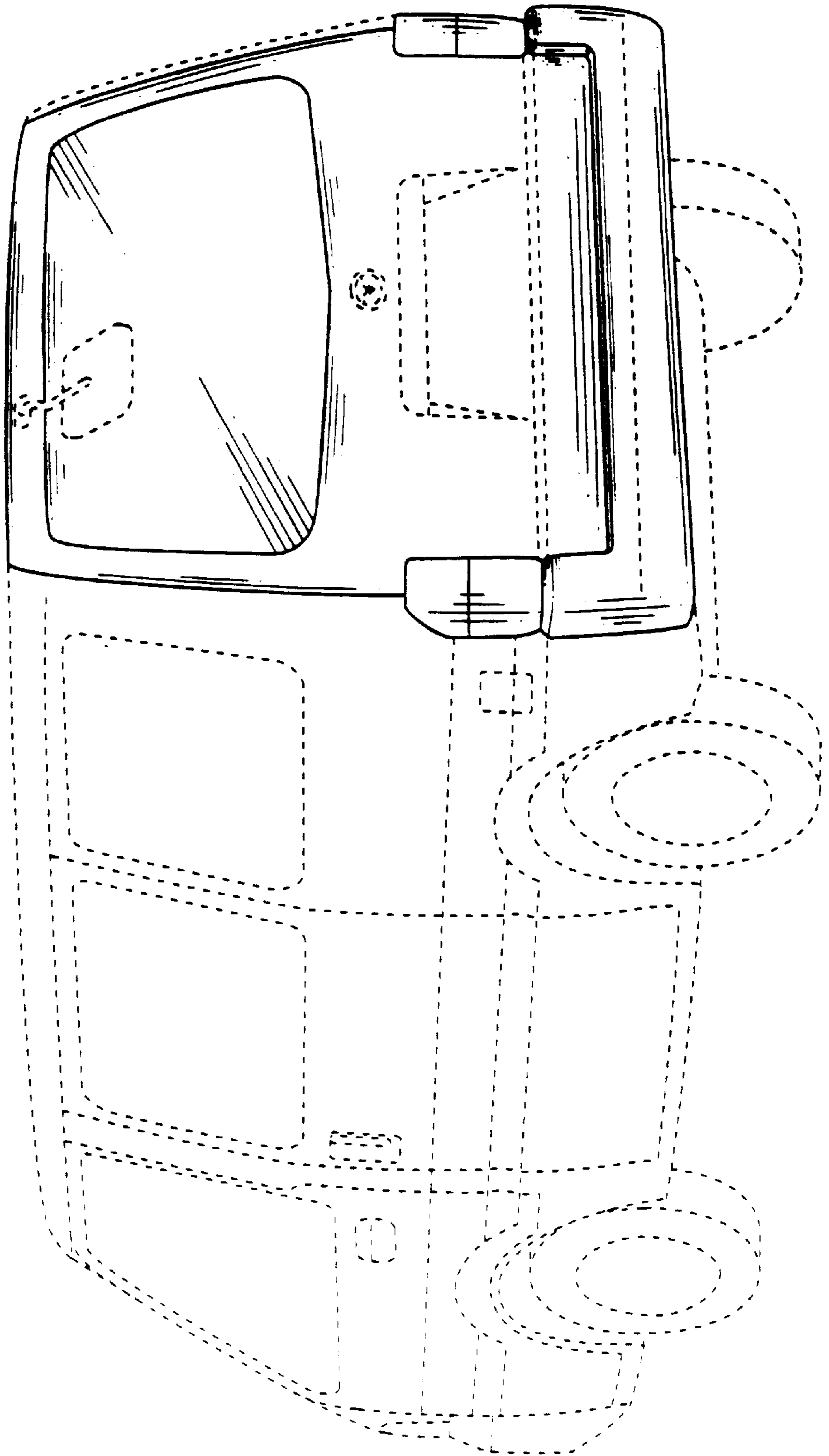

FIG. 7

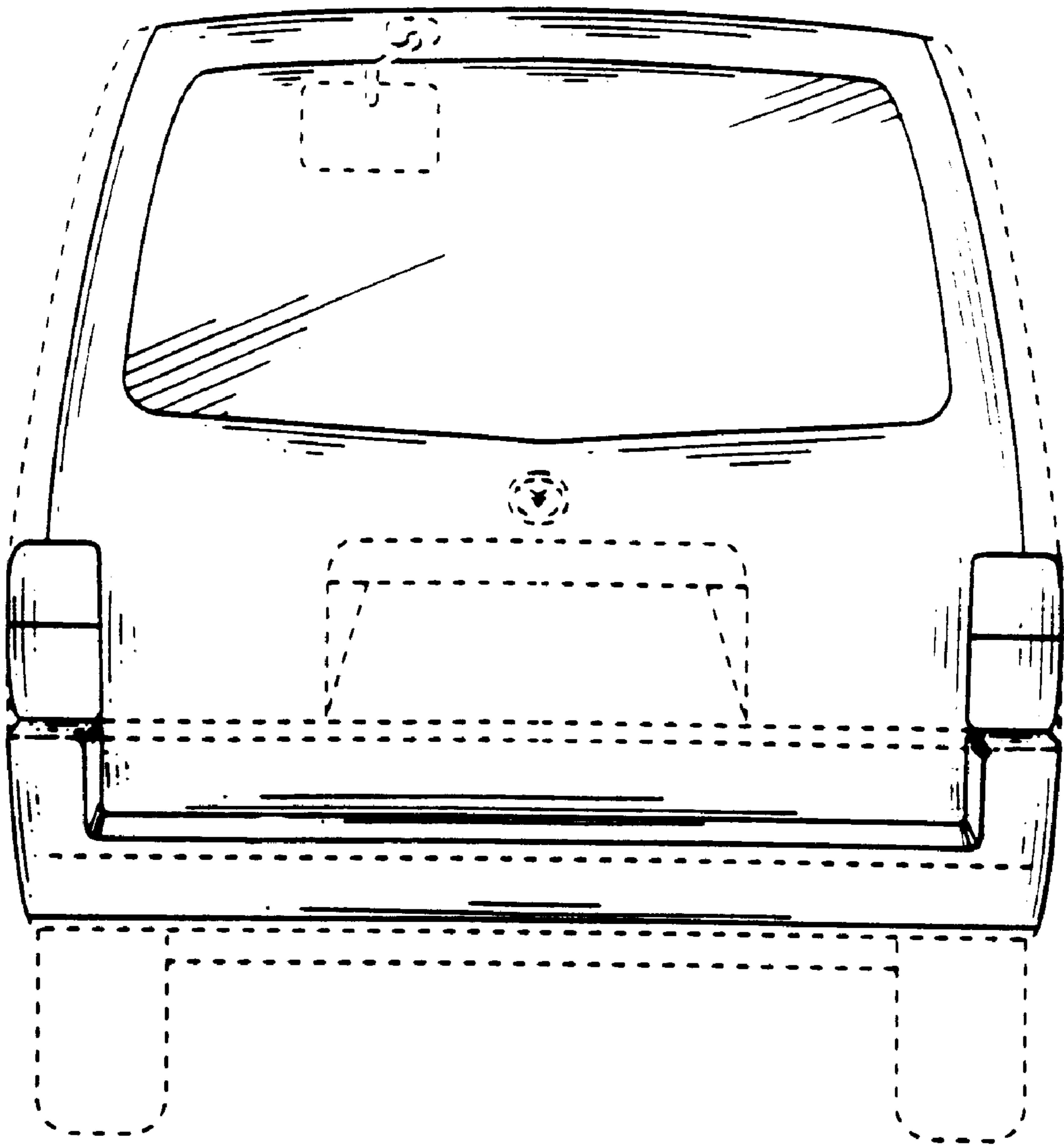

FIG. 8

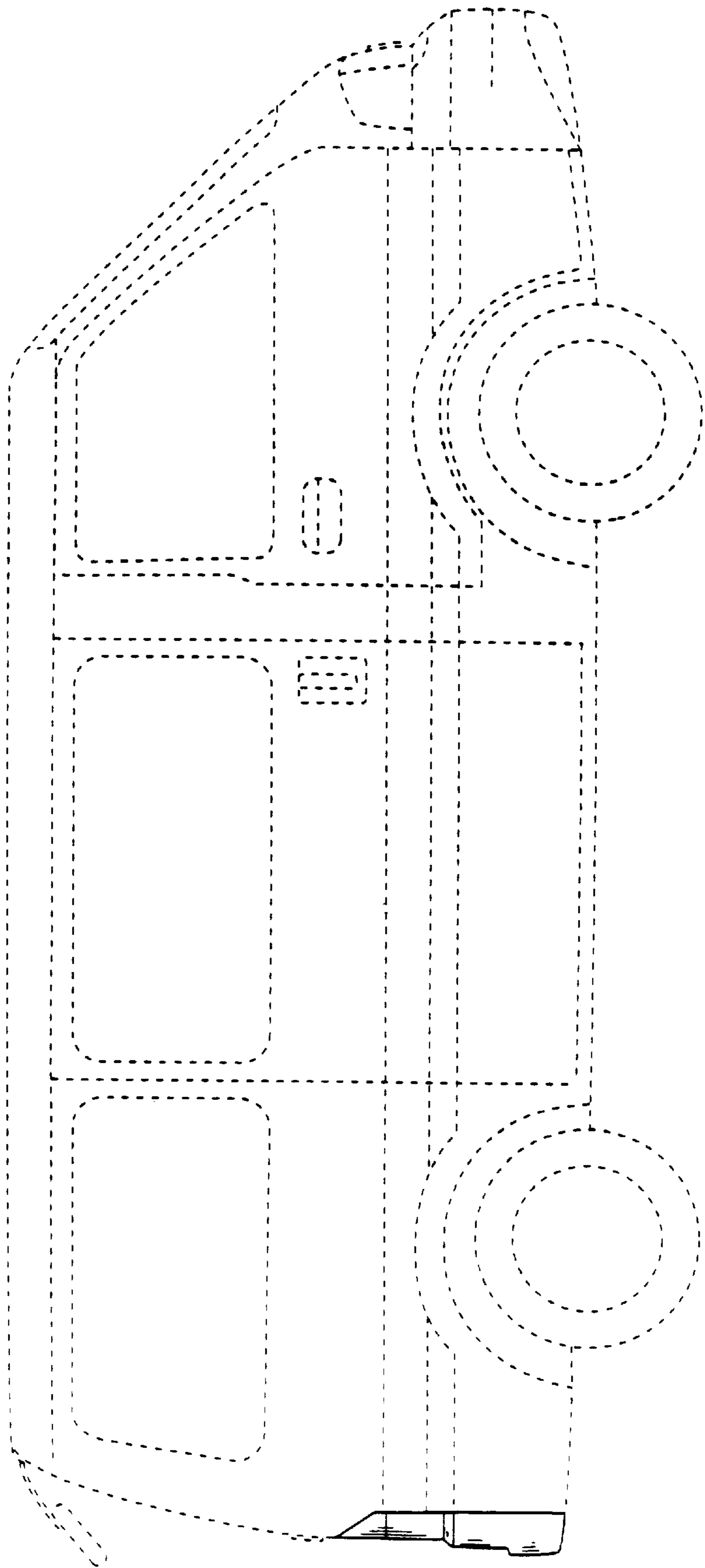

FIG. 9

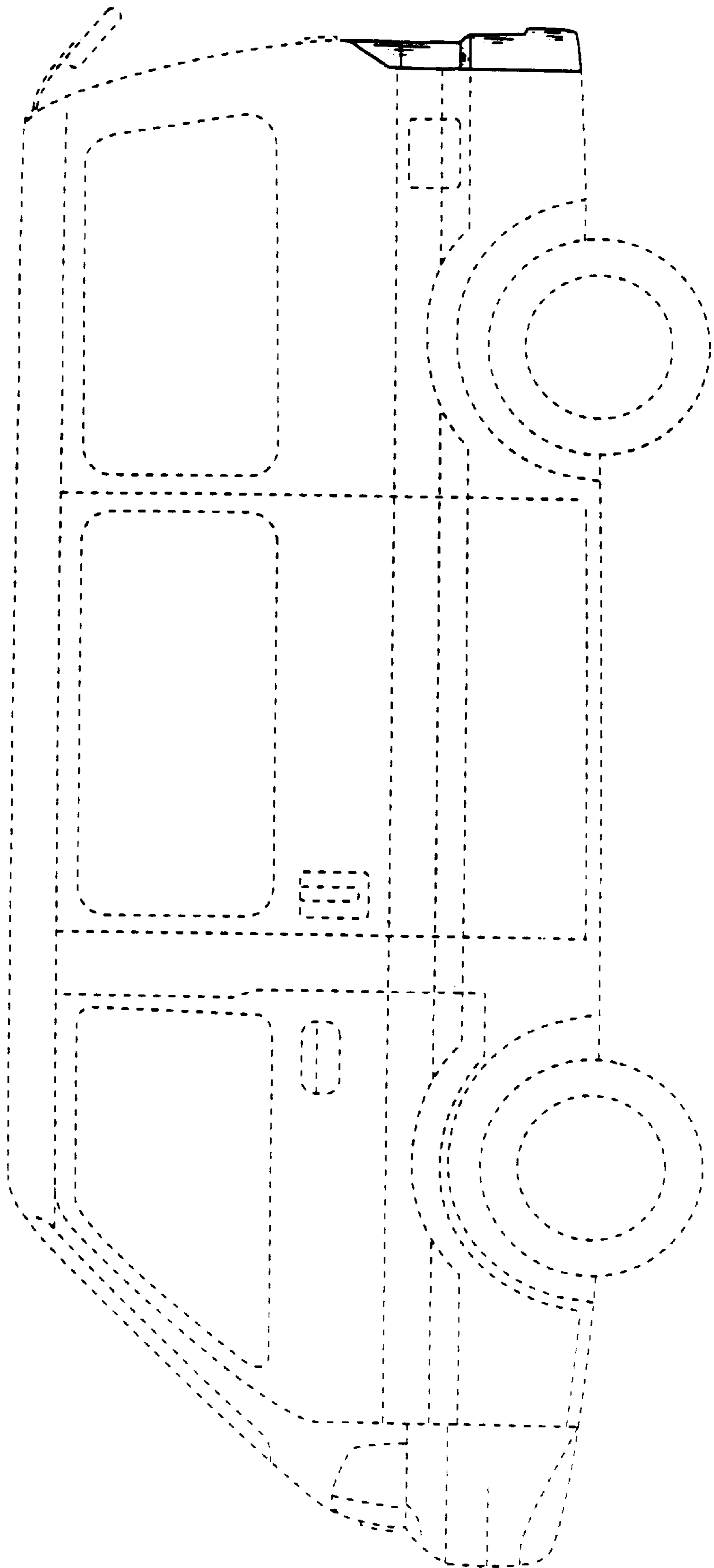

FIG. 10

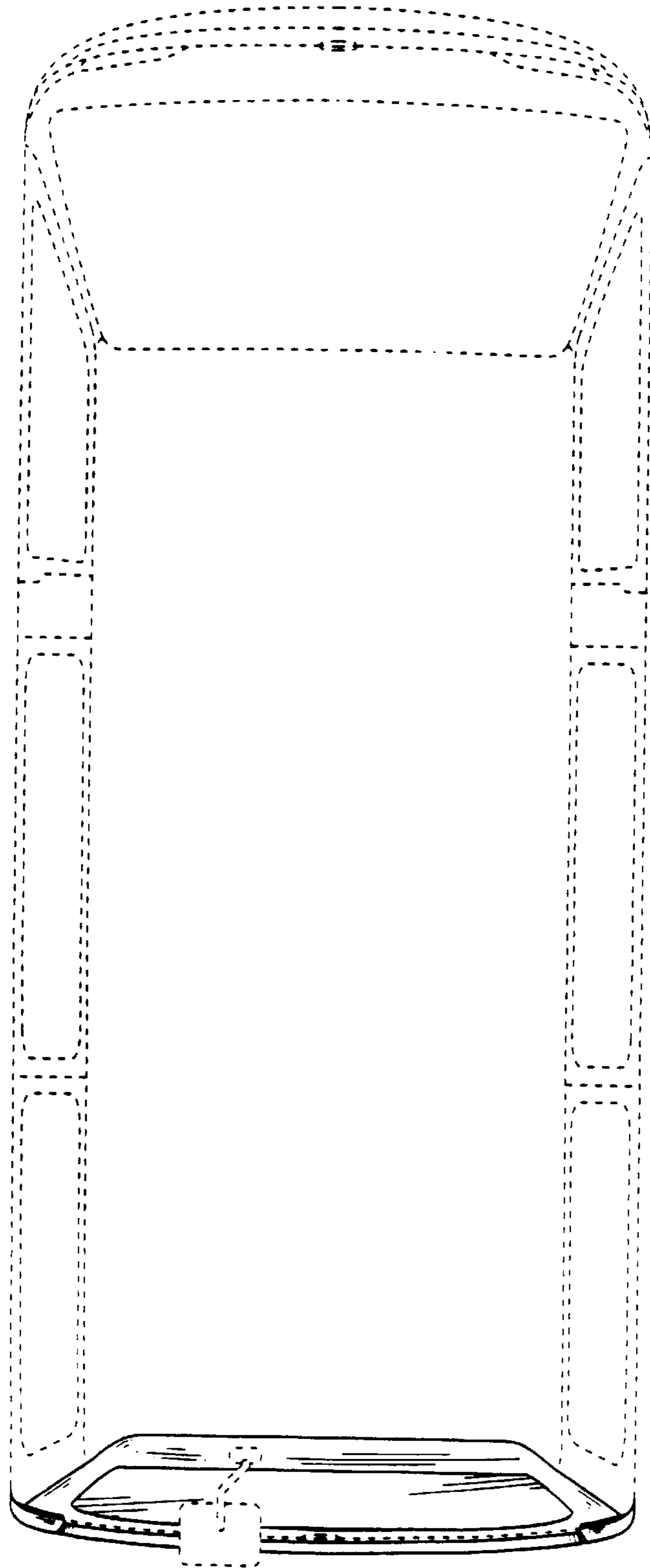

FIG. 11

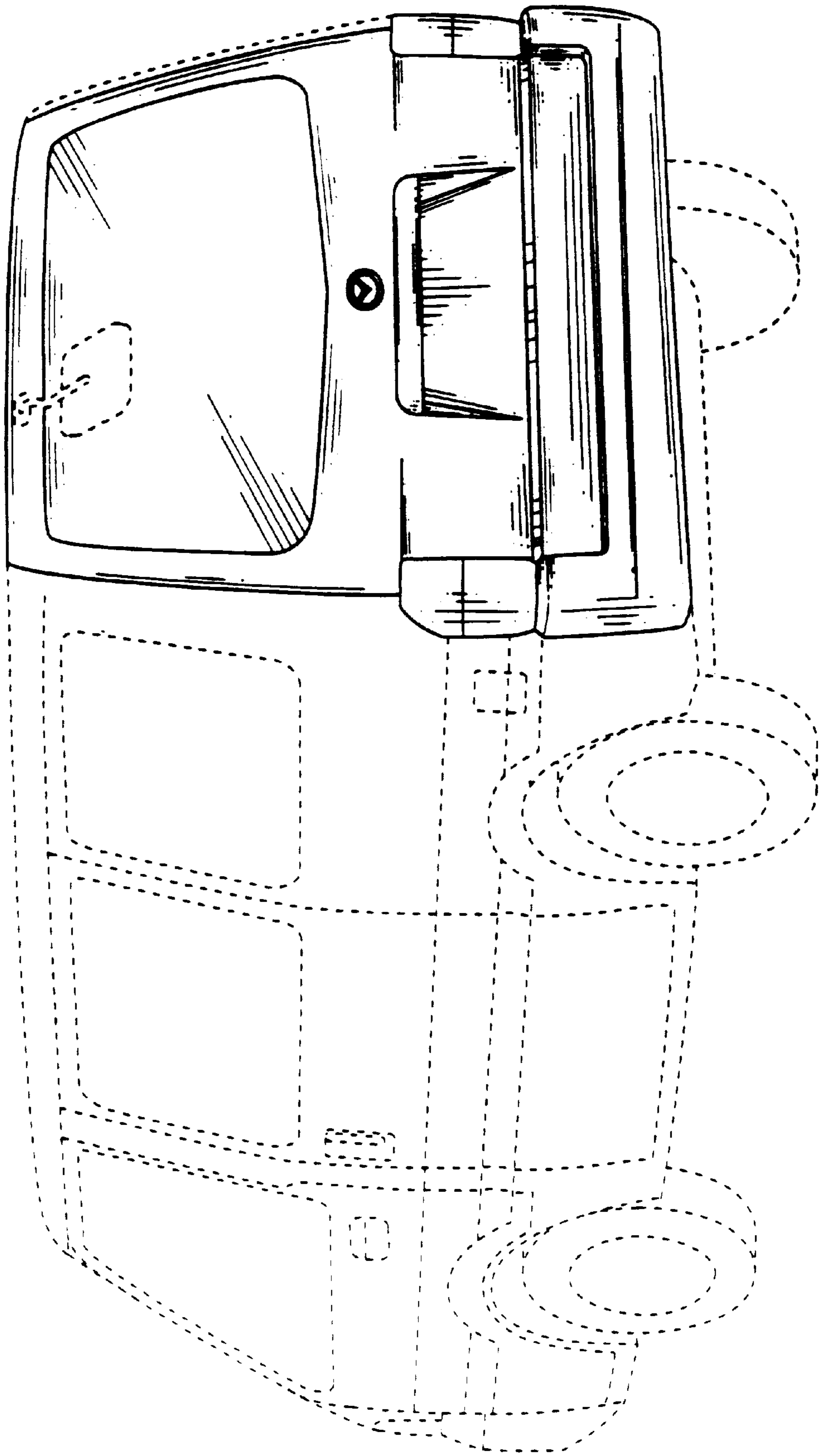

FIG. 12

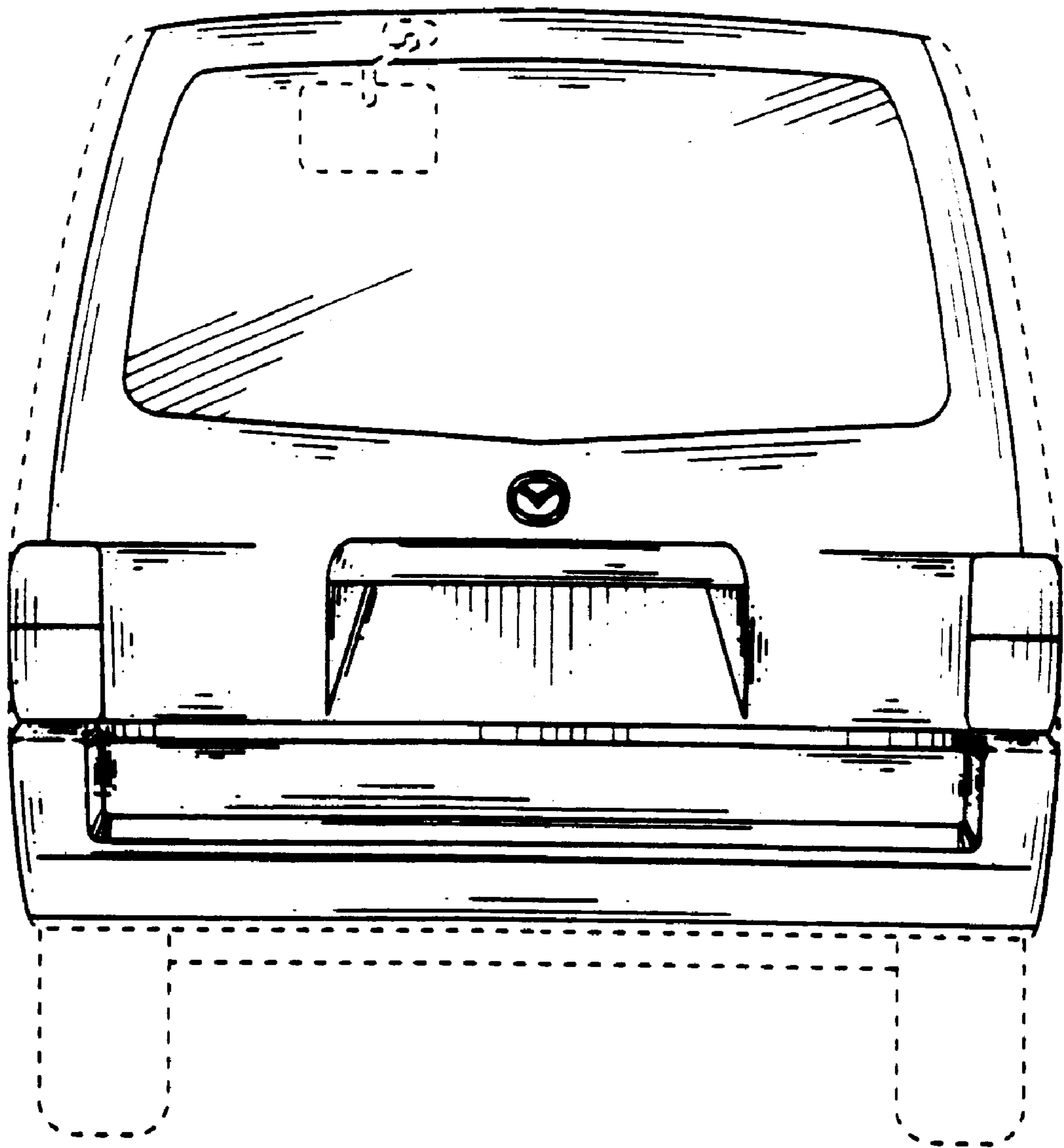

FIG. 13

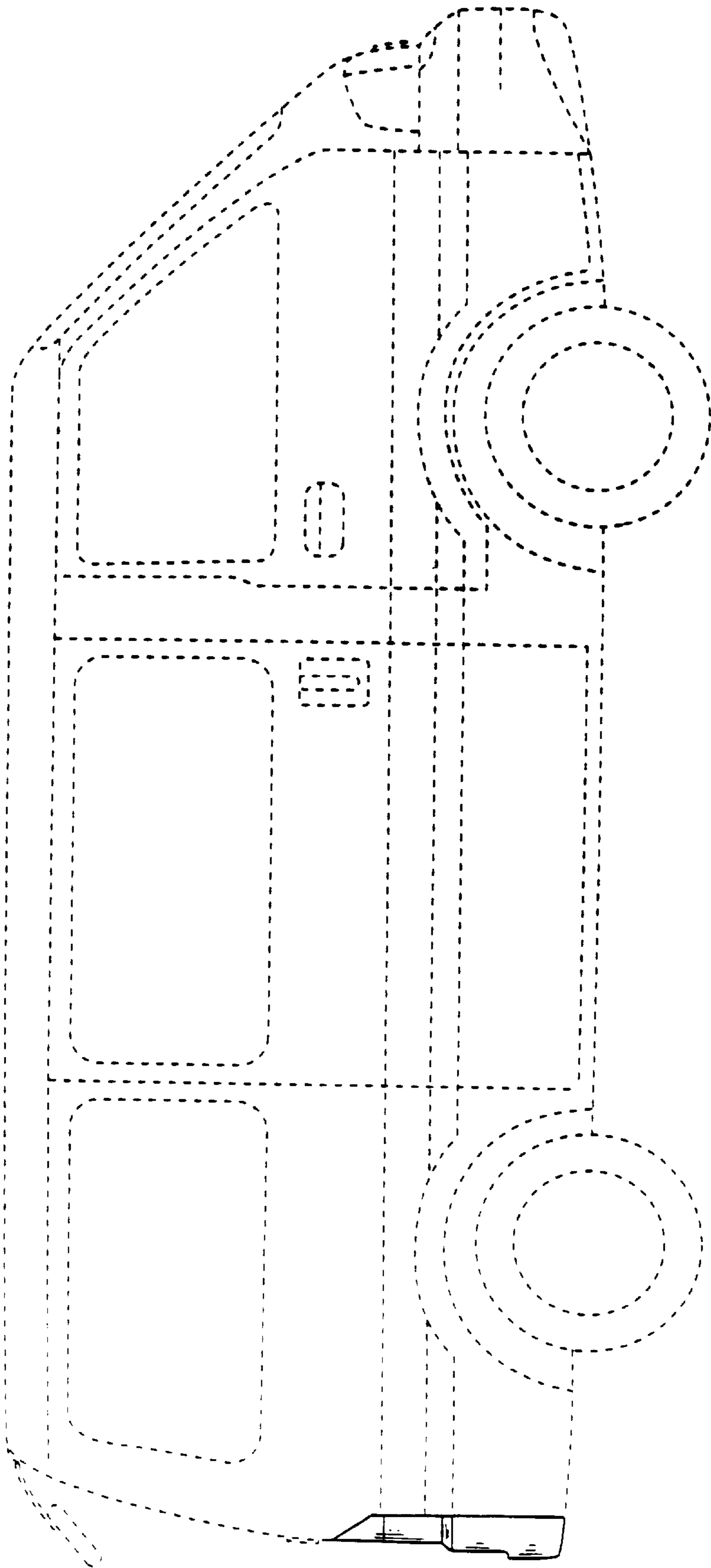

FIG. 14

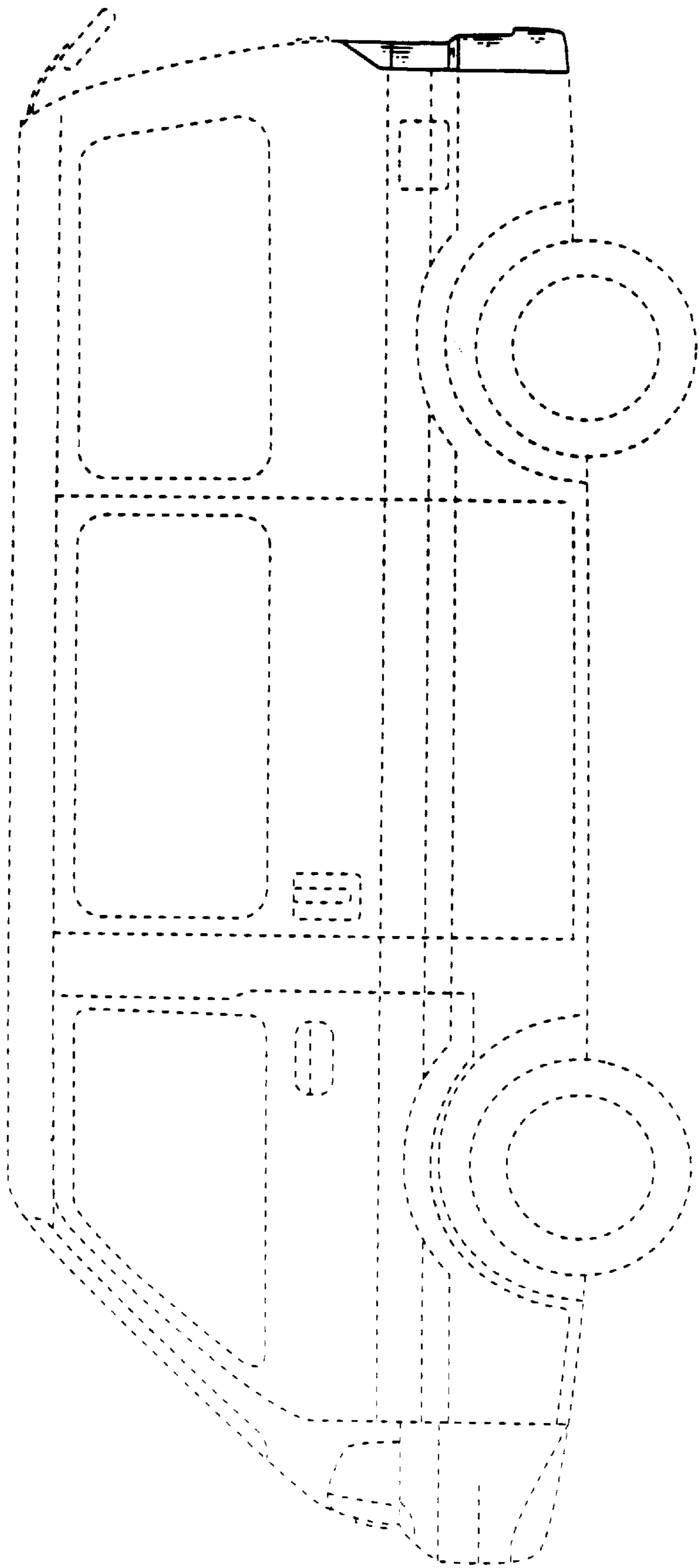

FIG. 15

